

RTKA223183DE0010BU

Dual output 6W universal Input Flyback Evaluation Board using RAA223183

The dual output 6W universal input Flyback evaluation board, RTKA223183DE0010BU, featured RAA223183 1000V regulator evaluates a low-cost, high-performance isolated AC/DC solution from a universal input of 85V_{AC} to 265V_{AC}, to 13V and 5V outputs for smart Meter applications.

The RTKA223183DE0010BU has proprietary cost-saving features, such as the short-time heavy load operation, which eliminates the need for transformer over-design for the heavy load in communication, and a single 400V electrolytic capacitor for input voltage up to 450V_{AC}, saving 3x capacitances. The board operates in DCM with constant frequency at 50kHz in normal operation, complimented with valley switching, which reduces switching losses and EMI noises. The board has built-in protections for over-load, short-circuit, input brownout, V_{CC} UV, V_{CC} OV, V_{IN} UV, peak current limit, primary short and over temperature protections. With a low-cost input EMI filter, the board is pre-compliant with EN55022/CISPR 22 Class B conducted EMI limits and has the 4kV surge capability by IEC61000-4-5 standard.

Features

- Operational input voltage up to 450V_{AC}
- Short-time heavy load support
- Single bus capacitor design for input up to 450V_{AC}
- Low BOM cost design
- EMI compliance for EN55022/CISPR22
- Surge test compliance to IEC61000-4-5 up to 4kV

Specifications

This board is optimized for the following operating conditions:

- Input voltage: 85V_{AC} ~ 265V_{AC}
- Operating temperature: -40C~95C
- Output: 13V/450mA; 5V/100mA
- Output power: 6W
- Max short-time load support (80ms):
 - 11W - 85V_{AC}~265V_{AC} input
 - 15W - 120V_{AC}~265V_{AC} input
- Efficiency: >75% at 100% load; >75% at 50% load
- Load regulation: 13V: <2%; 5V: <8%, 10% to 100% load
- Board dimension: 48mm×29mm

Contents

1. Functional Description	3
1.1 Recommended Equipment	3
1.2 Setup and Configuration	3
2. Board Design	4
2.1 Photo	4
2.2 Schematic Diagrams	5
2.3 Layout Guidelines	6
2.4 Board Layout	6
2.5 Bill of Materials	7
2.6 Transformer Specifications	9
3. Typical Performance Graphs	10
3.1 V_{IN} OV Capacitor Saver Protection	11
3.2 Short-Time Heavy Load	12
3.3 EMI Performance	13
4. Ordering Information	13
5. Revision History	13

1. Functional Description

The RTKA223183DE0010BU consists of a low-cost input stage^[1], the power stage^[2], and the control circuit surrounding the RAA223183 Flyback controller.

The input stage ensures the power supply meets the requirement set by the UL safety, IEC surge immunity, and IEC-conducted EMI standards. The power converter is fed with a rectified voltage buffered by C9 (when Q1 is on). The voltage regulation of two outputs is implemented by a secondary side TL431 circuit and an optocoupler, U2, with weighted feedback through R3, R1, and R5. In this design, 13V has dominant feedback (~85% weight), and 5V has lighter feedback (~15% weight). R12 sets the switching frequency at 50kHz. R13 sets the maximum power for the chosen transformer. C10 sets the maximum allowed time for a transient overload. C2 ensures the proper operation of CDRV for surge events and input over-voltage protection ($C2 \geq 3900\text{pF}$ recommended).

1.1 Recommended Equipment

- An AC Power supply capable of generating AC voltage from $85V_{AC}$ to $265V_{AC}$ at 60Hz/50Hz, with at least 100mA output current capability.
- A load resistor box with an adjustable value of 29Ω and up or an electronics load that can emulate a resistor load or current load up to 450mA for 13V output. A load resistor box with an adjustable value of 50Ω and up or an electronics load that can emulate a resistor load or current load up to 100mA for 5V output.
- Multimeters to measure the output voltage and current
- Power meter to measure the AC input power

1.2 Setup and Configuration

1. Program the AC power supply with a voltage between $85V_{AC}$ and $265V_{AC}$ at the corresponding frequency of 60Hz or 50Hz.
2. While the AC power supply is off, connect the output cables of the AC power supply to the L and N terminals of the RTKA223183DE0010BU. An optional power meter can be added between the AC power supply output and the input of the board.
3. Connect the corresponding load to the output terminal 13VOUT and GND and 5VOUT and GND, respectively.
4. Connect a voltage meter to VOUT and GND and connect a current meter between the board outputs and the load.
5. Turn on the AC power supply.

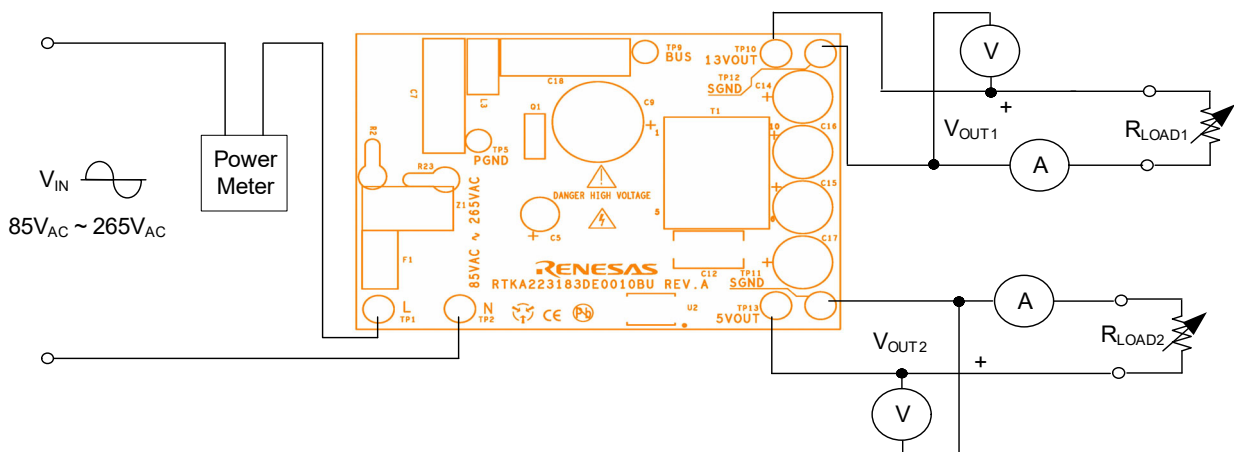

Figure 1. RTKA223183DE0010BU Connection Diagram

1. F1, Z1, R2, R23, D1, C7, L3, C18, and optional L1
2. C9, T1, D8, C14, C16, D9, C15 and C17

2. Board Design

2.1 Photo



Figure 2. RTKA223183DE0010BU Evaluation Board (Top)

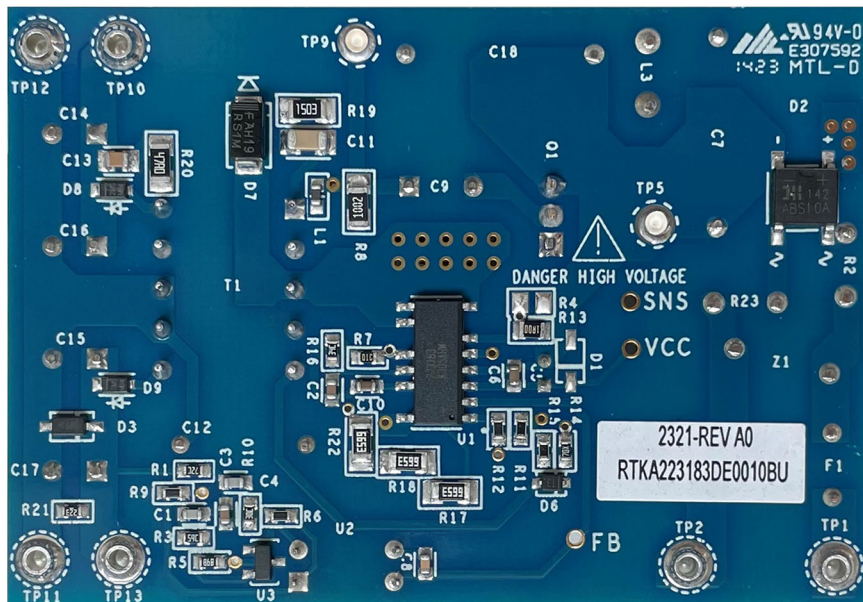

Figure 3. RTKA223183DE0010BU Evaluation Board (Bottom)

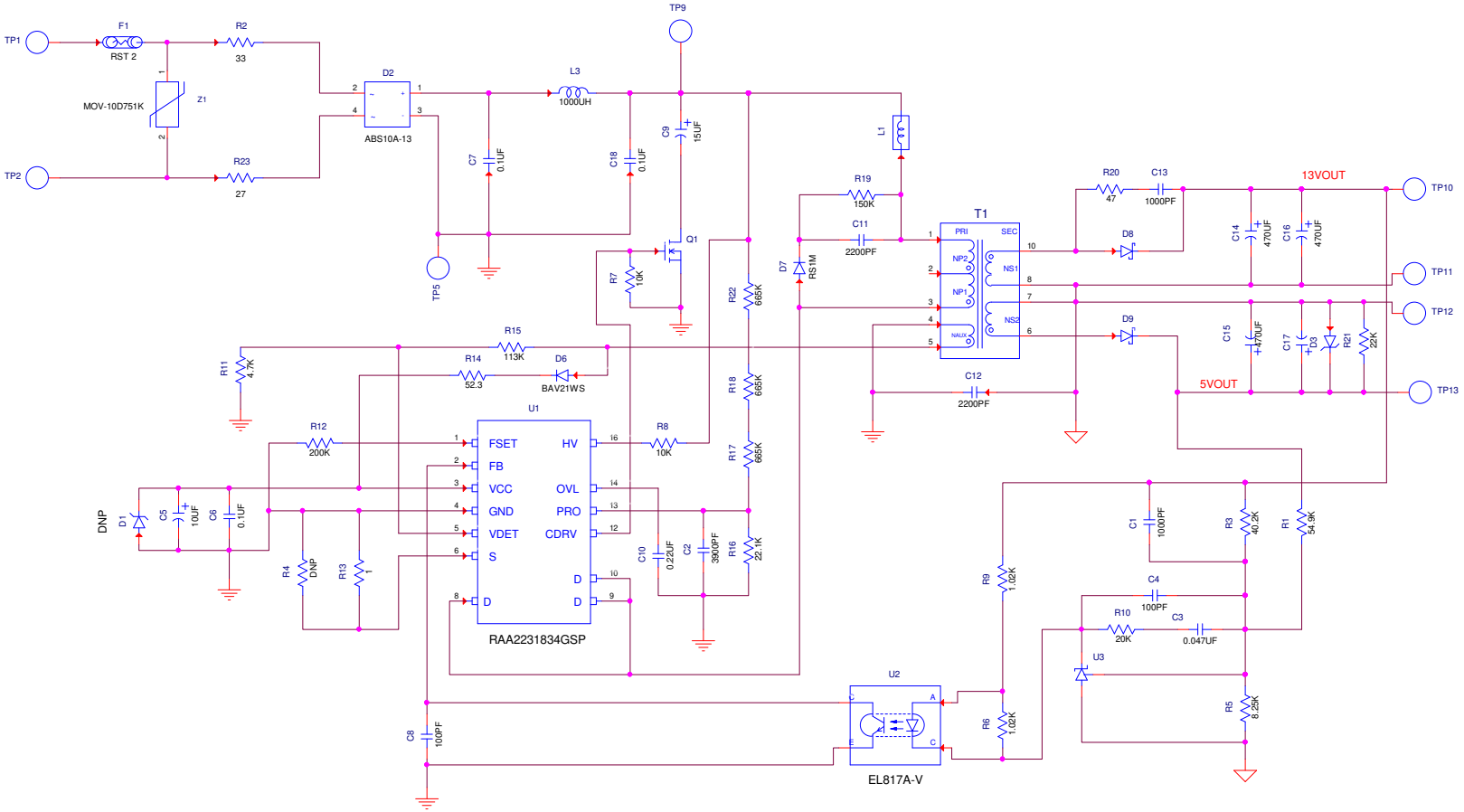

Figure 4. RTKA223183DE0010BU Schematic

2.2 Schematic Diagrams

2.3 Layout Guidelines

Proper layout is important to ensure a stable operation, good thermal behavior, EMI performance, and reliable operation for various operating environments. Pay attention to the following layout recommendations:

- Leave proper spacing. Recommend a minimum of 1.5mm between traces with voltage differences up to 400V and 2mm between traces with voltage differences up to 780V.
- Keep a small loop from the input bulk capacitor, transformer primary winding, D pin, and S pin to the MOSFET source pin that is connected with the input bulk capacitor. Also keep a small loop consisting of the secondary winding, rectifier diode, and output capacitor.
- Use the star connection of ground traces as shown in the top layout picture (Figure 5). The connection point needs to be close to the IC ground pin.
- Place the VCC decoupling capacitor close to the VCC pin.
- Keep sufficient copper area on the IC drain pin (around 165mm² for single-phase 6W output or 3-phase 11W output) for better thermal performance.
- Make the traces connected to secondary rectifier diodes thick enough so they provide enough heat dissipation.

2.4 Board Layout

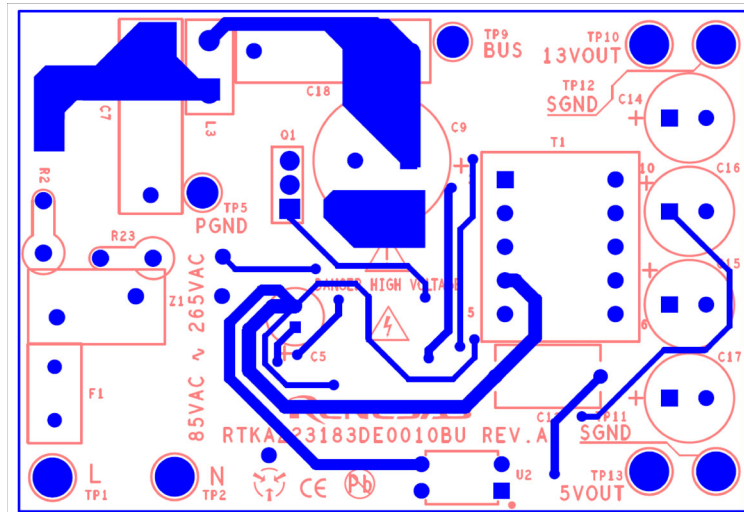

Figure 5. Top Layer

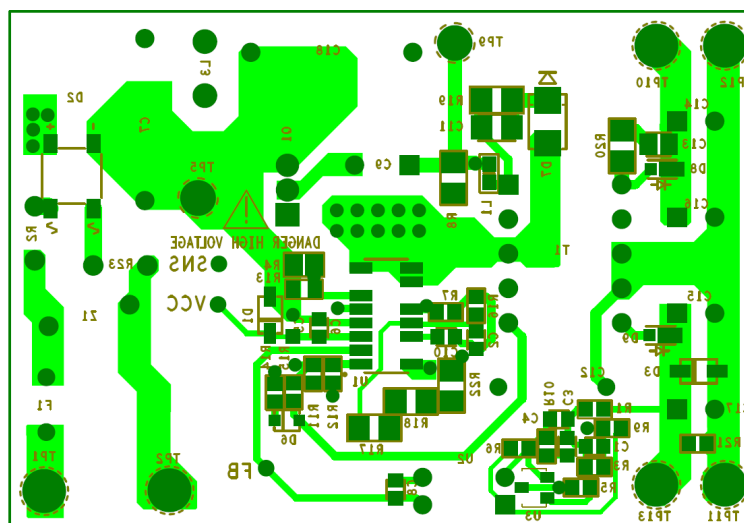

Figure 6. Bottom Layer

2.5 Bill of Materials

Qty	Reference Designator	Description	Value	Manufacturer	Manufacturer Part Number
1	F1	Fuse	2A, 250V _{AC} , Radial	Bel Fuse	RST 2
1	D2	1A 1000V Bridge Rectifier	1A, 1000V, ABS	Diodes Inc	ABS10A-13
0	D1	Zener Diode	DNP	-	-
1	D3	Zener Diode	5.6V, 500mW, SOD-123	Micro commercial	BZT52C5V6-TP
1	D6	General Purpose Diode	0.2A, 200V, SOD-323	Micro commercial	BAV21WS-TP
1	D7	Fast Recovery Diode	1A, 1kV, SMA	On-semi	RS1M
2	D8, D9	SCHOTTKY RECTIFIER	2A, 120V, DO-219AD	Vishay	V2PM12
1	L1	Ferrite Bead, SMD	60Ω at 100MHz, 0603	Murata	BLM18PG600SN1D
1	L3	Fixed Inductor	1mH, 5%, 0.1A, Axial	TDK	B78108S1105J000
1	C1	Multilayer Ceramic Cap	1000pF, 10%, 50V, 0603	Generic	Various
1	C2	Multilayer Ceramic Cap	3900pF, 10%, 50V, 0603	Generic	Various
1	C3	Multilayer Ceramic Cap	47nF, 10%, 50V, 0603	Generic	Various
1	C4	Multilayer Ceramic Cap	100pF, 10%, 50V, 0603	Generic	Various
1	C5	Multilayer Ceramic Cap, X7R	0.1μF, 10%, 50V, 0603	Generic	Various
1	C6	Aluminum Cap, radial	10μF, 20%, 25V, 0603	Nichicon	UMV1E100MFD1TP
1	C8	Multilayer Ceramic Cap	100pF, 10%, 50V, 0603	Generic	Various
1	C9	Aluminum Electrolytic 105C rated 10khrs	15μF, 20%, 400V, Radial	Nichicon	UCS2G150MHD
1	C10	Multilayer Ceramic Cap	0.22μF, 10%, 25V, 0603	Generic	Various
1	C11	Multilayer Ceramic Cap	2.2nF, 10%, 630V, 1206	Murata	GRM31BR72J222KW01L
1	C12	AC Rated Class Y1 Ceramic Disk Capacitor	2200pF, 20%, 500VAC	Vishay	VY1222M37Y5VQ63V0
1	C13	Multilayer Ceramic Cap	1nF, 10%, 200V, 0805	Generic	Various
2	C7, C18	Film Cap, Radial	0.1μF, 10%, 630V, Radial	Panasonic	ECW-FE2J104KA
2	C14, C16	Aluminum Electrolytic 105C rated 8khrs	470μF, 20%, 16V,RADIAL	Rubycon	16ZLH470MEFCT78X11.5
2	C15, C17	Aluminum Electrolytic 105C rated 6khrs	470μF, 20%, 10V,RADIAL	Rubycon	10YXF470MEFCT78X11.5
1	R1	Thick Film Chip Resistor	54.9k, 1%, 1/16W, 0603	Generic	Various
1	R2	Wirewound Resistors	33, 5%, 1W, axial	Yageo	KNP100JR-73-33R

Qty	Reference Designator	Description	Value	Manufacturer	Manufacturer Part Number
1	R3	Thick Film Chip Resistor	40.2K, 1%, 1/16W, 0603	Generic	Various
0	R4	Thick Film Chip Resistor	DNP	Generic	Various
1	R5	Thick Film Chip Resistor	8.25K, 1%, 1/16W, 0603	Generic	Various
2	R6, R9	Thick Film Chip Resistor	1.02K, 1%, 1/16W, 0603	Generic	Various
1	R7	Thick Film Chip Resistor	10K, 1%, 1/16W, 0603	Generic	Various
1	R8	Thick Film Chip Resistor	10K, 1%, 1/4W, 1206	Generic	Various
1	R10	Thick Film Chip Resistor	20K, 1%, 1/16W, 0603	Generic	Various
1	R11	Thick Film Chip Resistor	4.7k, 1%, 1/16W, 0603	Generic	Various
1	R12	Thick Film Chip Resistor	200k, 1%, 1/16W, 0603	Generic	Various
1	R13	Thick Film Chip Resistor	1, 1%, 1/8W, 0805	Bourns	Various
1	R14	Thick Film Chip Resistor	52.3, 1%, 1/16W, 0603	Generic	Various
1	R15	Thick Film Chip Resistor	113k, 1%, 1/16W, 0603	Generic	Various
1	R16	Thick Film Chip Resistor	22.1k, 1%, 1/16W, 0603	Generic	Various
3	R17, R18, R22	Thick Film Chip Resistor	665k, 1%, 1/8W, 1206	Generic	Various
1	R19	Thick Film Chip Resistor	150k, 1%, 1/8W, 1206	Generic	Various
1	R20	Thick Film Chip Resistor	47, 5%, 1/8W, 1206	Generic	Various
1	R23	Wire-wound Resistors	27, 5%, 1W, axial	Yageo	KNP100JR-73-27R
1	Q1	N-Channel MOSFET	650 V 4.3A TO-251	Infineon	IPS65R1K0CE
1	T1	Transformer	1.3mH, 10%, EE16, PTH	ITG	T201258A-1-30
1	U1	1000V, Off-line Flyback Regulator	RAA223183, SO13	Renesas	RAA223183
1	U2	Optocoupler	CTR: 80-160, PTH	Lite-On	LTV-817-A
1	U3	Shunt Regulator	TL431, SOT23	Nexperia	TL431AQDBZR,215
1	Z1	Varistor	750V 2.5KA PTH	Bourns	MOV-10D751K

2.6 Transformer Specifications

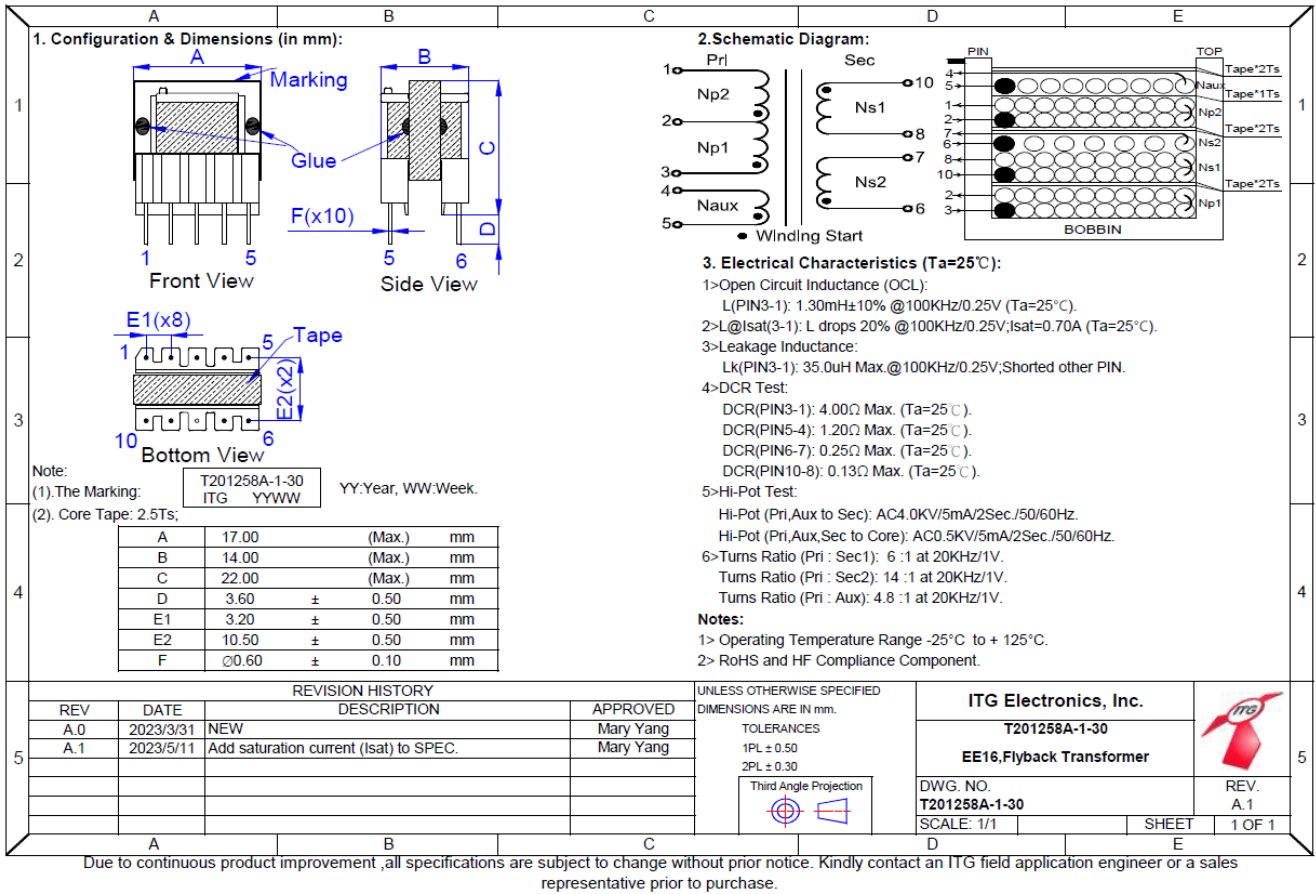

Figure 7. Transformer Specifications and Construction

The transformer for the EV board is a customized part by ITG, and has the following key characteristics:

- Low cost E16 core
- Meets 7.0mm clearance and creepage distance
- Reinforced insulation with triple insulated wires
- Isolation voltage: 4kV_{AC} (4kV_{AC} at 2s)
- Dual output
- Operating temperature: -25°C~+125°C
- RoHS and Halogen Free compliance

3. Typical Performance Graphs

$V_{IN} = 85V_{AC} \sim 265V_{AC}$, $V_{OUT1} = 13V$, $I_{OUT1} = 450mA$ (max), $V_{OUT2} = 5V$, $I_{OUT2} = 100mA$ (max), $T_A = +25^{\circ}C$

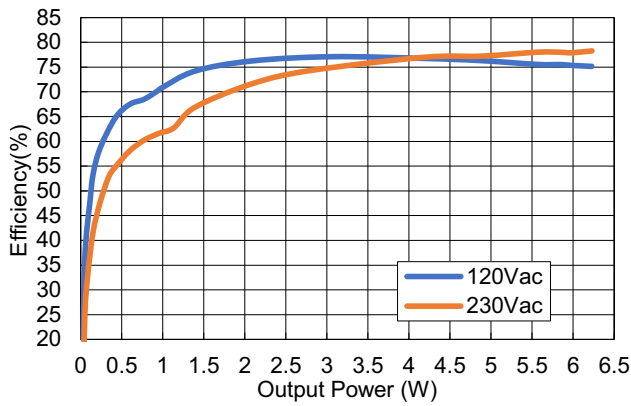

Figure 8. Efficiency Overload Range

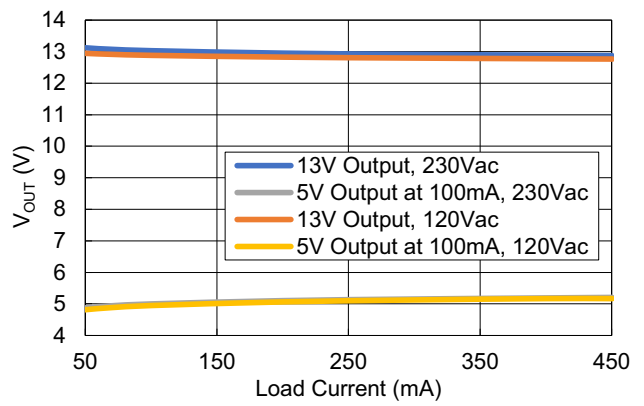

Figure 9. Load Regulation with 13V Load Sweep

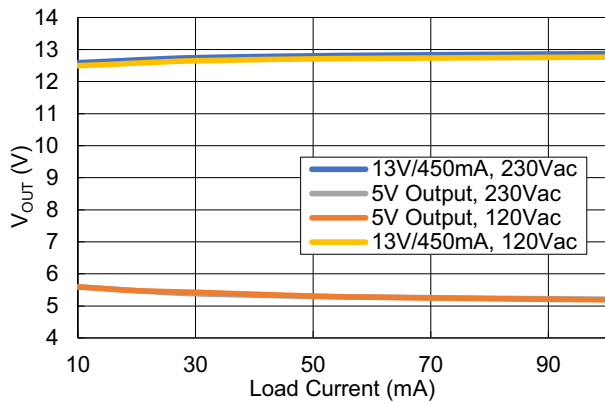

Figure 10. Load Regulation with 5V Load Sweep

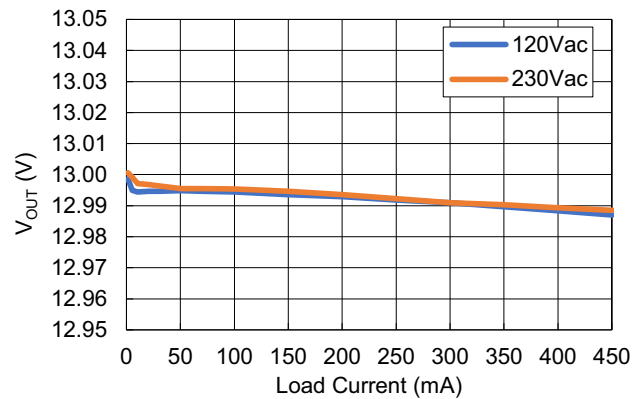

Figure 11. Load Regulation with Single Output (R5 = 9.31k, R1: Not Install)

Table 1. Typical No-Load and Light Load Power Consumption (25°C Ambient)

Input Voltage	No-load Power	Input Power with 50~70mW Load
120V _{AC} /60Hz	230mW	142~178mW
230V _{AC} /50Hz	460mW	193~230mW

3.1 V_{IN} OV Capacitor Saver Protection

The RTKA223183DE0010BU demonstrates a reliable V_{IN} OV operation that protects the input bulk capacitor from damage during substantial V_{IN} overvoltage. The following waveforms show how the board reacts to an input OV at initial startup (Figure 12), steady state operation (Figure 13), and when the input OV is removed (Figure 14).

$$V_{IN} = 356V_{AC}, V_{OUT1} = 13V, I_{OUT1} = 450mA, V_{OUT2} = 5V, I_{OUT2} = 100mA, T_A = +25^{\circ}C$$

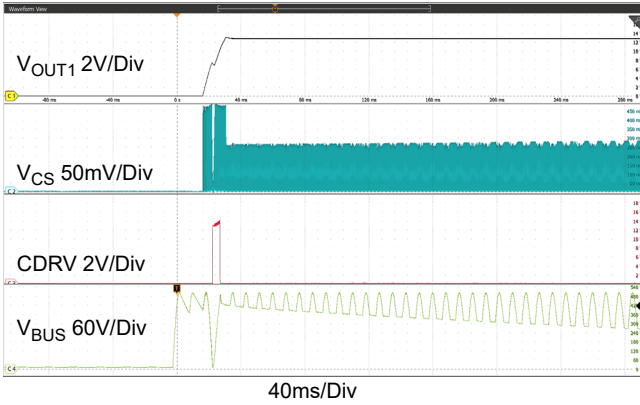

Figure 12. Startup into V_{IN} OV ($V_{IN} = 350V_{AC}$)

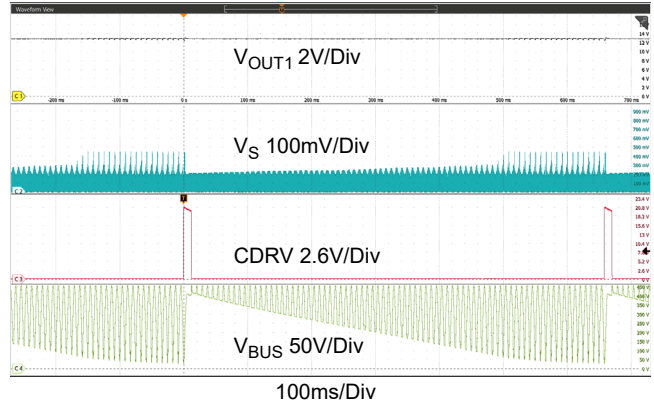

Figure 13. Steady State Operation with $V_{IN} = 350V_{AC}$

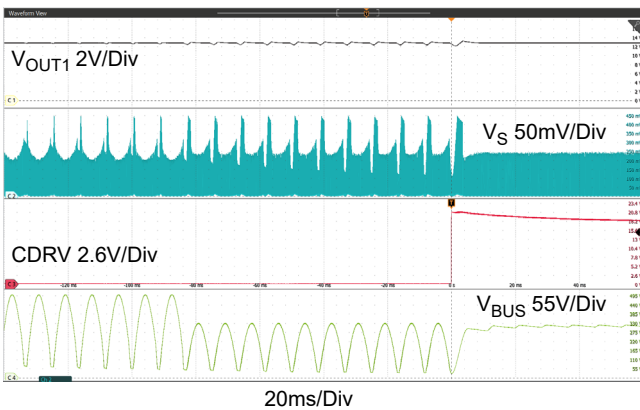

Figure 14. Exits V_{IN} OV ($V_{IN} = 230V_{AC}$)

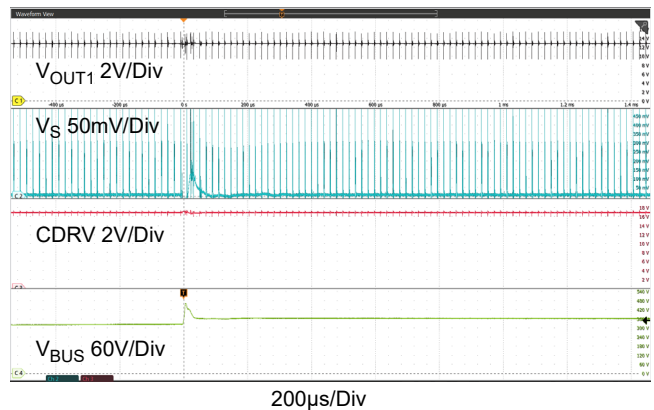

Figure 15. Waveforms at 4kV Surge Test

As Figure 12 shows, the external FET, Q1, at startup, is off before IC starts switching. So almost all the input voltage is applied across the FET. Therefore, the MOSFET must be rated with the corresponding rectified peak voltage of the max withstanding AC voltage, which is 650V in our design, for the max 460V_{AC} input. When the Q1 is turned on at a BUS valley created by IC switching, the IC detects the OV condition in the first half line cycle and turns off Q1 to protect the bulk capacitor, while the IC keeps switching so the power delivery is not interrupted in V_{IN} OV.

Figure 13 shows the Q1 stays off in most of the V_{IN} OV operation unless when the BUS voltage drops low enough (the bulk capacitor is completely depleted), it turns on briefly and turns off again once the bulk cap is charged. Due to the continuous PWM switching, the output voltage is regulated well, although there is some small line frequency ripple when the bus voltage ripple reaches full amplitude. It is usually sufficient for most load circuits supplying uninterrupted power to critical devices, such as an MCU, to save system information and send the fault signal.

The input surge events are one exception that Q1 should not be turned off at V_{IN} OV. Because the surge voltage is a relatively short pulse (~50µs) described by the IEC61000-4-5, a properly sized small ceramic cap can be connected to the PRO pin, so its voltage does not rise high enough to trigger the OV protection. The calculation is shown on Equation 12 on the datasheet. On the other hand, Q1 has to have enough pulse power capability to handle the surge current passing through it. Some input resistors can help to reduce the surge current. According

to the bench test, the peak pulse current going through Q1 is at least 10A and causes a transient voltage > 100V across Q1 within 30µs, with a total resistance (R2 and R23) of 55Ω or higher and a bulk capacitor of 15µF. Therefore, Q1 must be selected with at least a 10A pulse current rated at 100V VDS for a 10µs pulse to ensure it can handle the pulse power from a 4kV surge. The pulse current rating curves can be found in the Safe Operating Area graph on a MOSFET datasheet.

As previously mentioned, a sufficient input resistance can effectively suppress the surge energy passed into the bulk capacitor and the MOSFET, Q1. The actual resistance depends on the required surge test level. We found a 60Ω resistance can help the circuit pass the 4kV level test with some margin. Also, the input resistors have to be capable of pulse power. Wire-wound resistors are recommended for their robustness in transient high power.

3.2 Short-Time Heavy Load

The RTKA223183DE0010BU can support the short-time heavy load up to 80ms, as Figure 16 shows. The allowed operation time is limited by the capacitor on the OVL pin, as calculated by Equation 13 in the datasheet. A bigger OVL capacitor allows longer heavy-load operation. If the heavy load is removed before the programmed time, the IC switches at 2x frequency until the time is reached, as Figure 18 shows. When the OVL pin is grounded, the IC operates at 2x frequency indefinitely. How long the IC can operate in this mode depends on the thermal capability of the board design with the given IC thermal resistance. When the pin is floated, the 2x frequency operation is disabled.

$$V_{in} = 230Vac, V_{OUT1} = 13V, V_{OUT2} = 5V, I_{OUT2} = 200mA, T_A = +25^{\circ}C$$

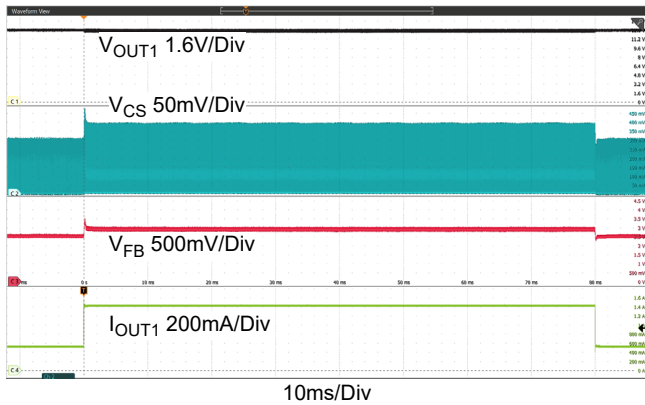

Figure 16. Short-Time Heavy Load Operation

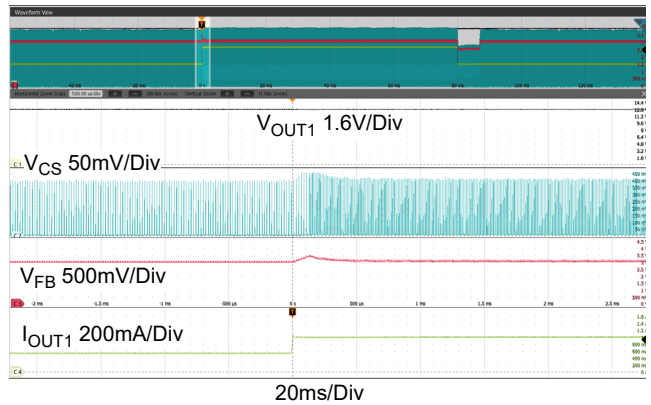

Figure 17. Zoomed View of Short-Time Heavy Load Operation

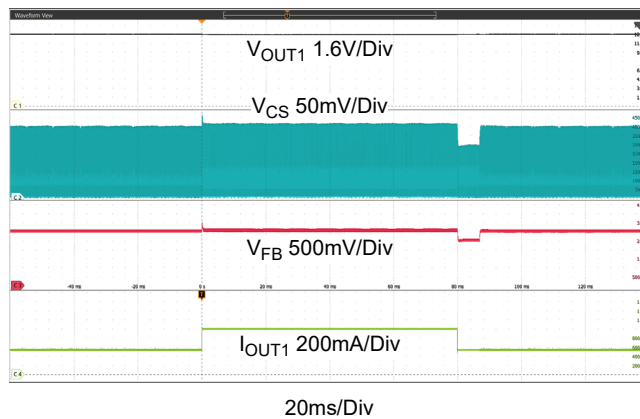

Figure 18. Heavy Load Lasts Shorter than the Programmed Time Length

3.3 EMI Performance

RTKA223183DE0010BU is compliant to the conducted EMI requirements of FCC Part 15 and CISPR22 Class B.

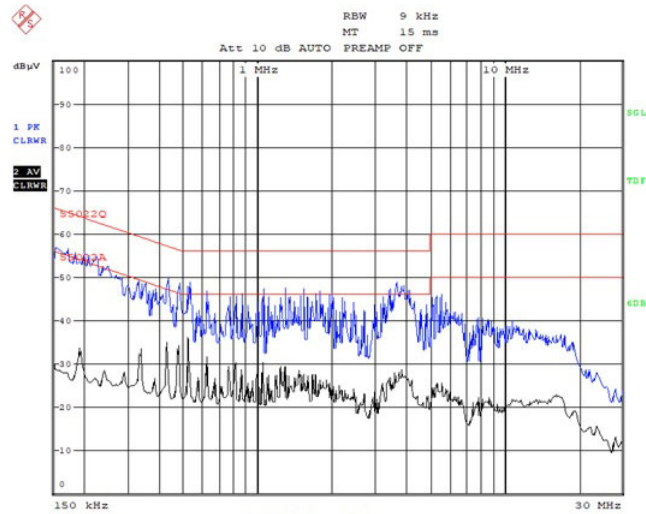

Figure 19. 120V_{AC} Line

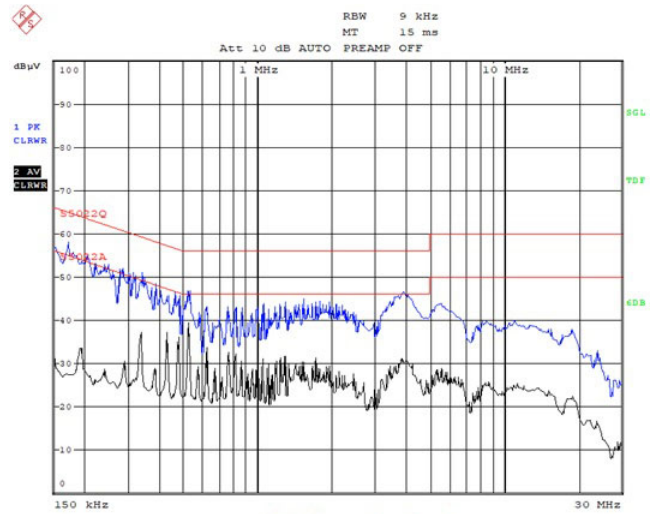

Figure 20. 120V_{AC} Neutral

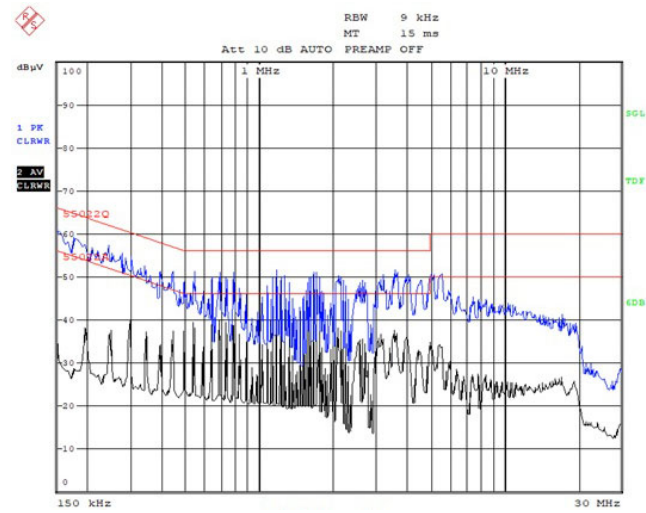

Figure 21. 230V_{AC} Line

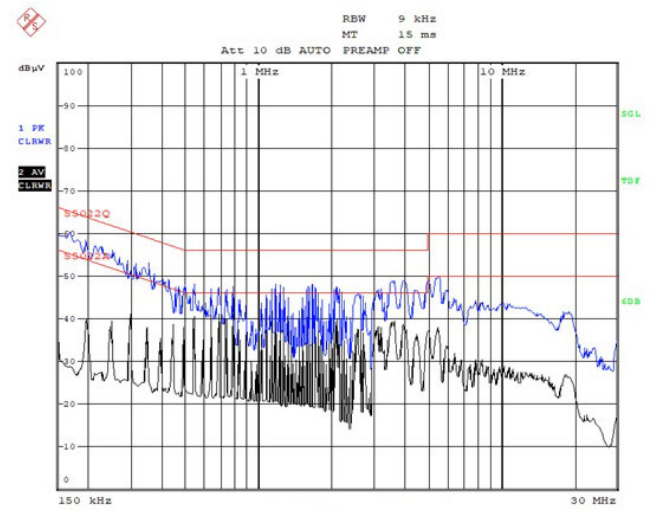

Figure 22. 230V_{AC} Neutral

4. Ordering Information

Part Number	Description
RTKA223183DE0010BU	RAA223183 Evaluation Board

5. Revision History

Revision	Date	Description
1.01	Mar 8, 2024	Updated BOM
1.00	Sep 8, 2023	Initial release

IMPORTANT NOTICE AND DISCLAIMER

RENESAS ELECTRONICS CORPORATION AND ITS SUBSIDIARIES (“RENESAS”) PROVIDES TECHNICAL SPECIFICATIONS AND RELIABILITY DATA (INCLUDING DATASHEETS), DESIGN RESOURCES (INCLUDING REFERENCE DESIGNS), APPLICATION OR OTHER DESIGN ADVICE, WEB TOOLS, SAFETY INFORMATION, AND OTHER RESOURCES “AS IS” AND WITH ALL FAULTS, AND DISCLAIMS ALL WARRANTIES, EXPRESS OR IMPLIED, INCLUDING, WITHOUT LIMITATION, ANY IMPLIED WARRANTIES OF MERCHANTABILITY, FITNESS FOR A PARTICULAR PURPOSE, OR NON-INFRINGEMENT OF THIRD-PARTY INTELLECTUAL PROPERTY RIGHTS.

These resources are intended for developers who are designing with Renesas products. You are solely responsible for (1) selecting the appropriate products for your application, (2) designing, validating, and testing your application, and (3) ensuring your application meets applicable standards, and any other safety, security, or other requirements. These resources are subject to change without notice. Renesas grants you permission to use these resources only to develop an application that uses Renesas products. Other reproduction or use of these resources is strictly prohibited. No license is granted to any other Renesas intellectual property or to any third-party intellectual property. Renesas disclaims responsibility for, and you will fully indemnify Renesas and its representatives against, any claims, damages, costs, losses, or liabilities arising from your use of these resources. Renesas' products are provided only subject to Renesas' Terms and Conditions of Sale or other applicable terms agreed to in writing. No use of any Renesas resources expands or otherwise alters any applicable warranties or warranty disclaimers for these products.

(Disclaimer Rev.1.01 Jan 2024)

Corporate Headquarters

TOYOSU FORESIA, 3-2-24 Toyosu,
Koto-ku, Tokyo 135-0061, Japan
www.renesas.com

Trademarks

Renesas and the Renesas logo are trademarks of Renesas Electronics Corporation. All trademarks and registered trademarks are the property of their respective owners.

Contact Information

For further information on a product, technology, the most up-to-date version of a document, or your nearest sales office, please visit www.renesas.com/contact-us/.