

Introduction

The VersaClock® 6E programmer board is made to ease the programming of blank 5P49V6965 or 5P49V6975 devices. With the on-board USB interface, the IDT [Timing Commander™](#) GUI can be used to communicate with the VersaClock® 6E device in the socket for configuration and programming of its OTP memory.

Board Overview

Use [Figure 1](#) and [Table 1](#) to identify board items and features.

Figure 1. Programmer Board Overview

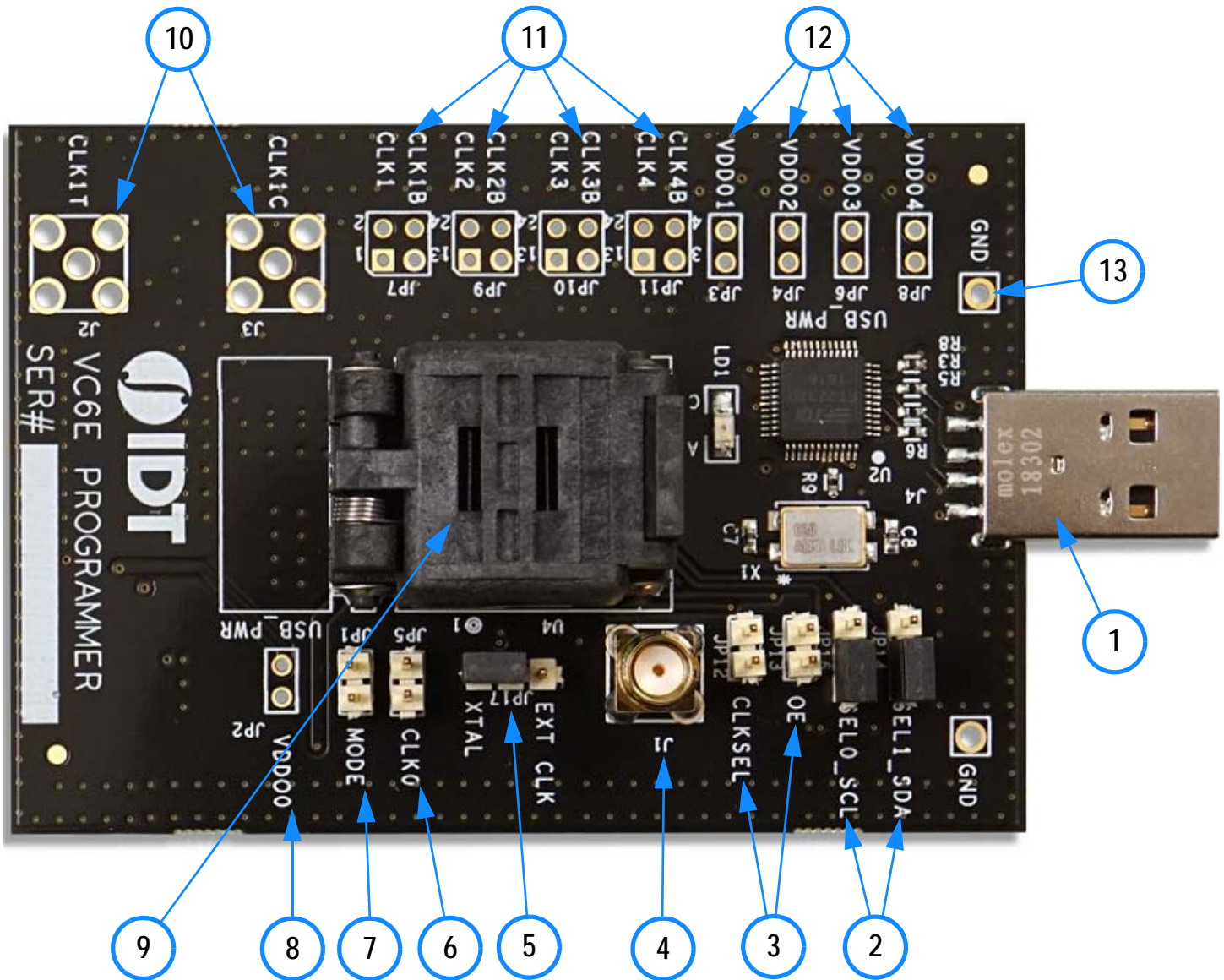

Table 1. 5P49V6965/5P49V6975 Programmer Board Pins and Functions

Label Number	Name	On-board Connector Label	Function
1	USB	J4	USB connector.
2	I2C / SEL	JP14, JP16	Jumpers to connect I2C or control SEL0/1.
3	OE / CLKSEL	JP12, JP13	Jumpers to control OE and CLKSEL.
4	Ref Clock Input	J1	SMA to connect alternative Ref Clock.
5	Input Clock Select	JP17	Select between on-board 25MHz crystal and alternative Ref Clock.
6	Output 0	JP5	Differential input clock, Sens output.
7	Operation Mode	JP1	Jumper to select I2C or Hardware Select Mode.
8	VDDO0	JP2	Optional VDD for output 0.
9	DUT Socket	U4	Socket for 5P49V6965/6975. Pin 1 is lower left.
10	Output 1 Diff	J2, J3	Optional output 1 differential connection.
11	Outputs 1, 2, 3, 4	J7, J9, J10, J11	2 × 2 pin probe points for outputs 1, 2, 3 and 4.
12	VDDO1, 2, 3, 4	JP3, JP4, JP6, JP8	Optional VDD for outputs 1, 2, 3 and 4.
13	Ground	—	Ground reference for general purpose.

Connecting the Board to a Computer

The programmer board can be plugged into a USB port of a personal computer directly, or, a USB extension cable can be used if that is more convenient. The on-board USB-to-I2C bridge (FTDI chip) does the data communication and the +5V in the USB bus powers the on-board regulator. The board can fully function with just the USB connection to a computer.

JP 14 and JP16 Functionality

JP14 and JP16 have multiple functions. The center pin of JP14 connects to the SEL1/SDA pin on the 5P49V6965/6975 and the center pin of JP16 connects to the SEL0/SCL pin on the 5P49V6965/6975.

Figure 2. JP14 and JP16 Jumpers

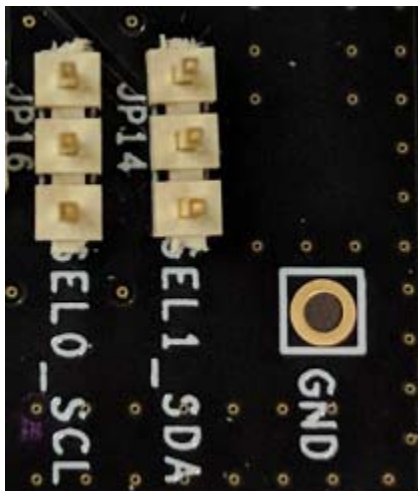

The bottom pins connect to the FTDI USB-to-I2C bridge. To use Timing Commander to communicate to the chip, jumpers need to be placed between the center and bottom pins as in [Figure 3](#).

Figure 3. JP14 and JP16 for I2C

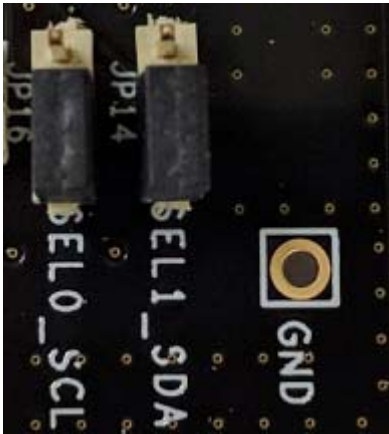
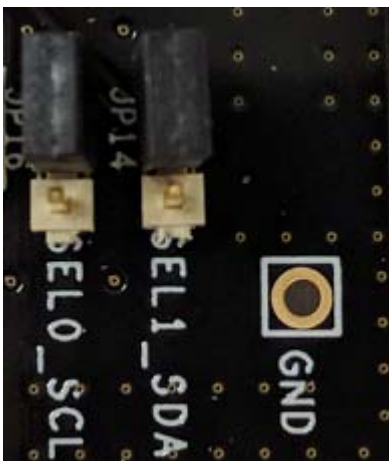

Figure 4. JP14 and JP16 for SEL0/1



After programming multiple configurations, the 5P49V6965/6975 can be restarted in Hardware Select mode and then the SEL0 and SEL1 pins can be used to select a configuration. The SEL0/1 pins on the 5P49V6965/6975 have pull-down resistors on the chip so when leaving the pins open, like [Figure 2](#), both SEL0 and SEL1 are low and configuration 0 is selected. The upper pins in JP14 and JP16 are pulled up to VDD so when placing jumpers as in [Figure 4](#), the SEL0 and SEL1 pins are pulled up. Placing the jumpers as in [Figure 4](#) selects configuration 3. Also see the chapter about the Mode jumper to use the Hardware Select mode.

JP14 and JP16 also allow wiring of the I2C bus into a system. As mentioned above, the bottom pins connect to the FTDI USB-to-I2C bridge. For SCL connect to the bottom pin of JP16, for SDA connect to the bottom pin of JP14 and for ground use the GND test point to the right of JP14 and JP16. These three wires can be connected to a 5P49V6965/6975 that is assembled in a system so Timing Commander can be used to control this remote 5P49V6965/6975.

JP12 and JP13 Functionality

JP12 controls the CLKSEL pin and JP13 controls the SD/OE pin on the 5P49V6965/6975. These pins have pull-down resistors on the chip so when the pins are left open, the pins will be pulled low. When placing a jumper, the pin will be pulled high. This way the functionality of the CLKSEL and SD/OE pins can be verified.

Figure 5. JP12 and JP13 Jumpers



J1 and JP17 Functionality

The programmer board has a 25MHz crystal assembled for use with the 5P49V6965. This 25MHz crystal is the default and recommended crystal. To use the 25MHz crystal, place a jumper to the left on JP17, as in [Figure 6](#). In case a different input frequency is needed, the jumper can be moved to the right, to connect J1 to the crystal input pin on the 5P49V6965. Using an RF generator, a different frequency can be applied to the crystal input pin through J1. The recommended amplitude is 0dBm to +3dBm or 600mVpp to 1Vpp.

The 5P49V6975 has an integrated crystal and therefore, J1 / JP17 have no function.

Figure 6. SMA and JP17 Jumper

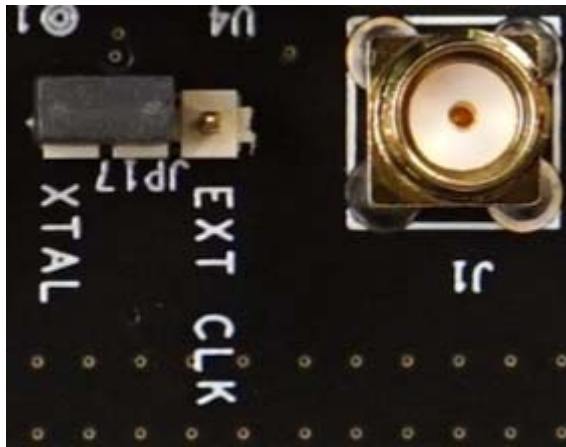

JP1 and JP5 Functionality

JP5 is the CLK0 output (OUT0) of the 5P49V6965/6975. The upper pin is ground and the lower pin is the actual output. Connect a probe between the upper (GND) and lower (OUT0) pins to measure the OUT0 frequency or waveform. JP1 can be used to select the operating Mode to be either I2C Mode or Hardware Select Mode. The mode is selected at power up so at the moment the board is plugged into a USB port. The proper method for using JP1 is to first unplug the board from USB, then change the JP1 jumper and plug the board back into a USB port. No jumper on JP1 selects the I2C mode where Timing Commander can communicate with the device. Having a jumper installed on JP1 selects the Hardware Select Mode for selecting a pre-programmed configuration with the SEL0 and SEL1 jumpers.

Figure 7. JP1 Jumper and JP5 Pins

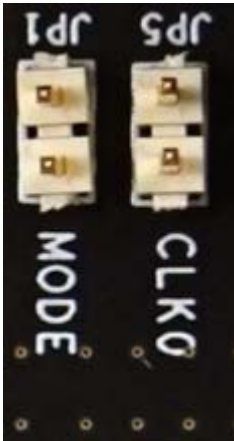

JP7, JP9, JP10 and JP11 Functionality

These four 2 × 2 test points are connected to the four differential outputs on the 5P49V6965/6975. The lower two pins are ground and the upper two pins are the actual output pins. A probe can be used to check the outputs, to measure the frequency or to check the waveform with an oscilloscope. Connect a single ended probe between a ground pin and output pin or connect a differential probe between the two output pins. Note that the output pins connect directly to the pins on the chip and there are no additional components for termination or biasing. For HCSL and LVPECL logic types, additional biasing is needed to allow the outputs to make sufficient signal swing.

Figure 8. JP7, JP9, JP10 and JP11 for CLK1, 2, 3 and 4 (OUT1, 2, 3 and 4)

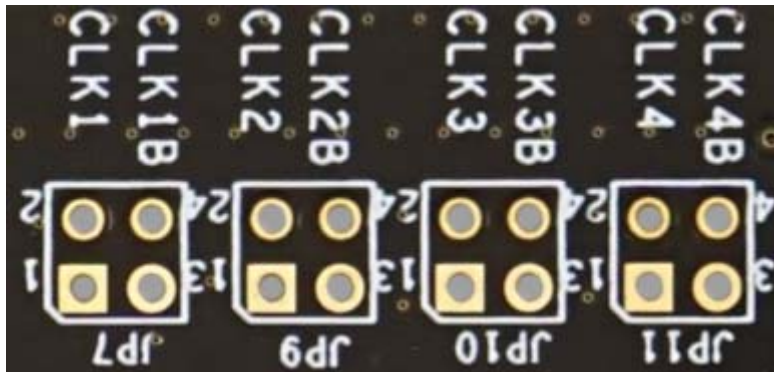

J2 and J3 Functionality

J2 and J3 are SMA footprints for an alternative differential connection to OUT1. The default programmer board does not have these connectors assembled.

Figure 9. J2 and J3 Alternative CLK1 (OUT1)

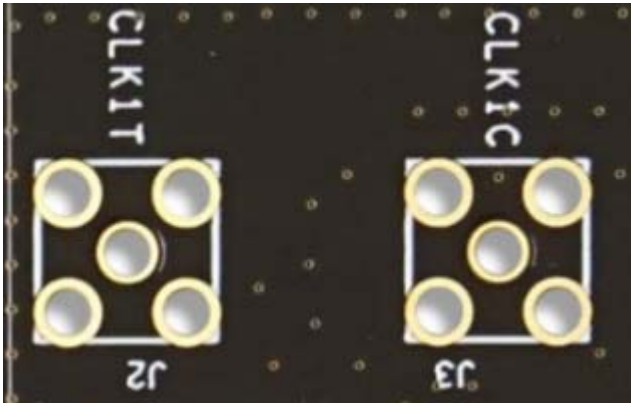

JP3, JP4, JP6 and JP8 Functionality

The default programmer board does not have jumper pins assembled for JP3, JP4, JP6 and JP8. The two pins in each jumper are shorted on the board with a 0 ohm resistor. The lower pins are connected to a 3.3V power regulator on the board. The upper pins are each connected to a different VDDO pin. So the programmer board connects each VDDO pin to 3.3V by default. This is sufficient when programming 5P49V6965 or 5P49V6975 devices and checking output frequencies. Jumper pins can be installed and the 0 ohm resistors can be removed to gain control of the VDDO pins. A jumper can be placed to connect to the on-board 3.3V regulator. Remove the jumper and connect the upper pin to an external power supply, in case a different voltage is needed. The ground side of the power supply can be connected to the GND point on the right.

Figure 10. JP3, JP4, JP6 and JP8 VDDO Connections

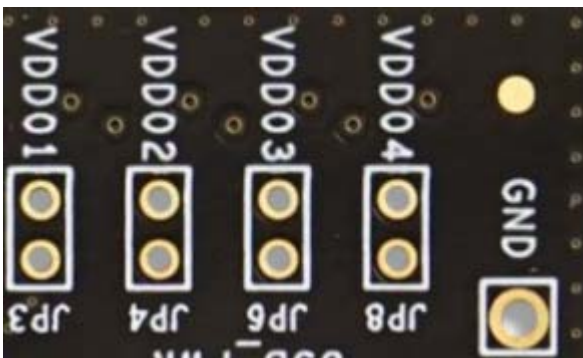

VC6E Programmer Board Compatibility

The VC6E programmer board hardware was designed for the 5P49V6965 and 5P49V6975 but is backwards compatible with older VC6 and VC5 devices. Essentially, this VC6E programmer board can do everything and more than the older VC5 programmer board.

This VC6E programmer board can be used with the following devices:

- Using the VC6E Timing Commander personality: 5P49V6965 and 5P49V6975.
- Using the VC6 Timing Commander personality: 5P49V6901, 5P49V6913 and 5P49V6914.
- Using the VC5 Timing Commander personality: 5P49V5901, 5P49V5913, 5P49V5914, 5P49V5923, 5P49V5925, 5P49V5927, 5P49V5929, 5P49V5933 and 5P49V5935.

This VC6E Programmer Board User Guide will only deal with the VC6E Timing Commander personality.

Configuration and Setup

Use the following steps to setup the 5P49V6965 or 5P49V6975 device using USB-to-I2C and start the configuration.

1. Before connecting the programmer board to USB, make sure JP1 is open (no jumper). Also see JP1 functionality and Figure 7.
2. Connect J4 to the USB port of a PC.
3. Launch VersaClock 6E Timing Commander Software (refer to VersaClock 6E Timing Commander User Guide). Download the [VersaClock 6E Timing Commander User Guide](#).
4. Following the Getting Started steps in the Timing Commander software, an I2C connection is established between the GUI software and the VersaClock 6E chip.
5. Select “Open Settings File” if you have existing settings or “New Settings File” and select 5P49V6965 or 5P49V6975 depending on the device in the socket. In the same screen, browse for the VersaClock 6E personality file, by clicking on the button at the bottom right.
6. Connect to the device by clicking on the microchip icon located at the top right of the Timing Commander screen.



7. Once connected, new options will be available on a green background indicating that Timing Commander has successfully connected with the device in the socket. Write settings to the chip by clicking on the write all registers to the chip option.



8. All intended outputs should now be available for measurement. At this point only the volatile memory (registers) is programmed. When unplugging the board to remove power, the configuration is erased.
9. After connecting to the chip, the OTP button will be available to enter the menu for burning OTP. First enter a configuration before burning OTP. Configurations can be burned only once.

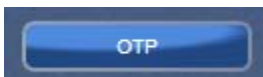

10. After opening the OTP Burn menu, one or more configurations can be selected for burning to OTP. In the example below, only configuration 0 is selected to be burned to OTP.



11. After finishing the burning to OTP, the device can be tested as follows:

- Unplug USB to remove power.
- Place JP1 to make the device start in Hardware Select mode the next time USB (power) is plugged in again.
- Place jumpers on JP14 and JP16 for selecting a specific configuration. No jumpers for configuration 0. Also see JP14 and JP16 functionality above. For checking configuration 0, it is not necessary to place a jumper on JP1. When starting in I2C mode, configuration 0 is loaded by default.
- Plug in USB to power up the board and the correct frequencies should be available on outputs, according to the configuration that was burned to OTP.

Schematics

Programmer board schematics are shown on the following pages.

Figure 11. 5P49V6965/6975 Programmer Board Schematics - page 1

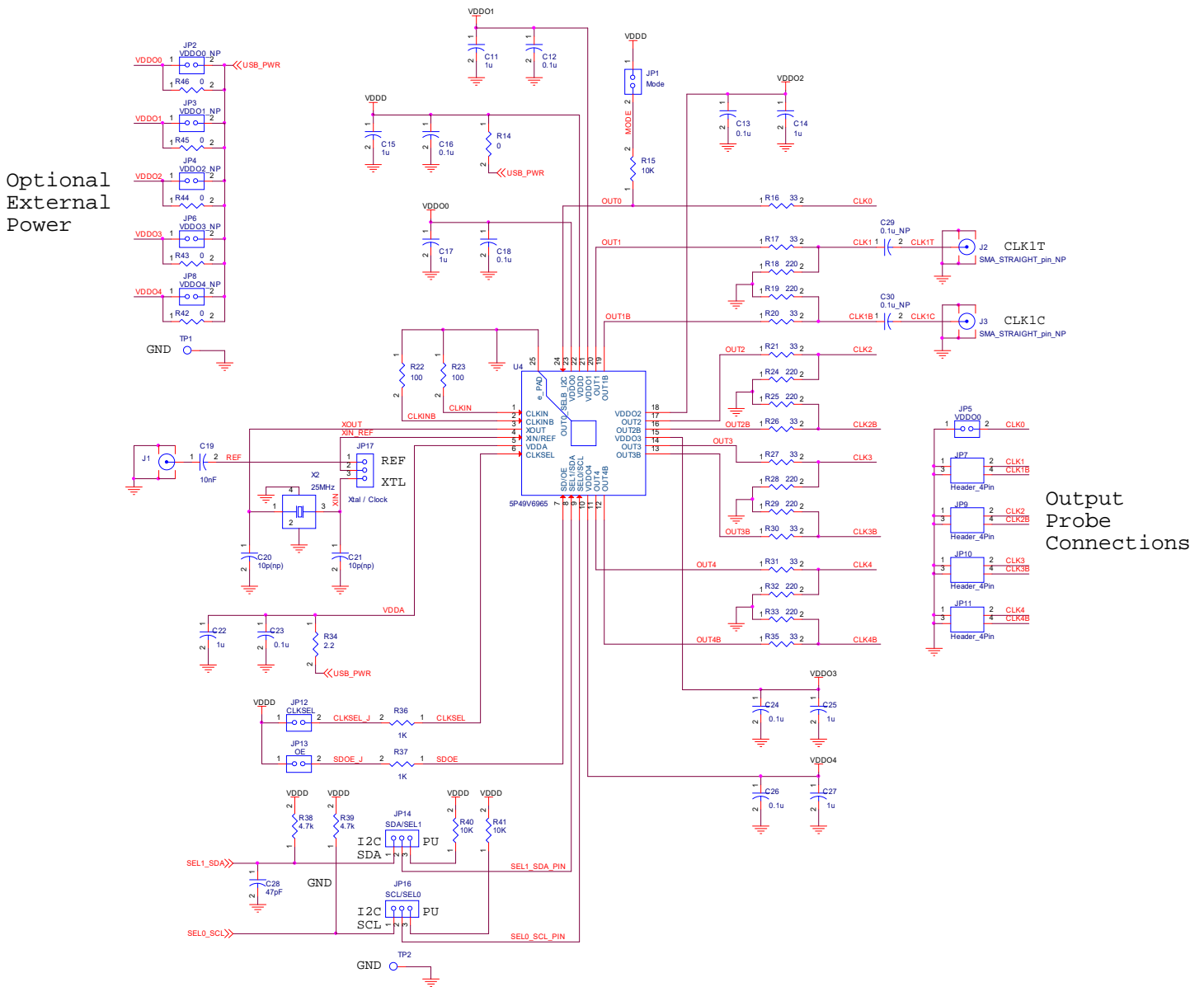
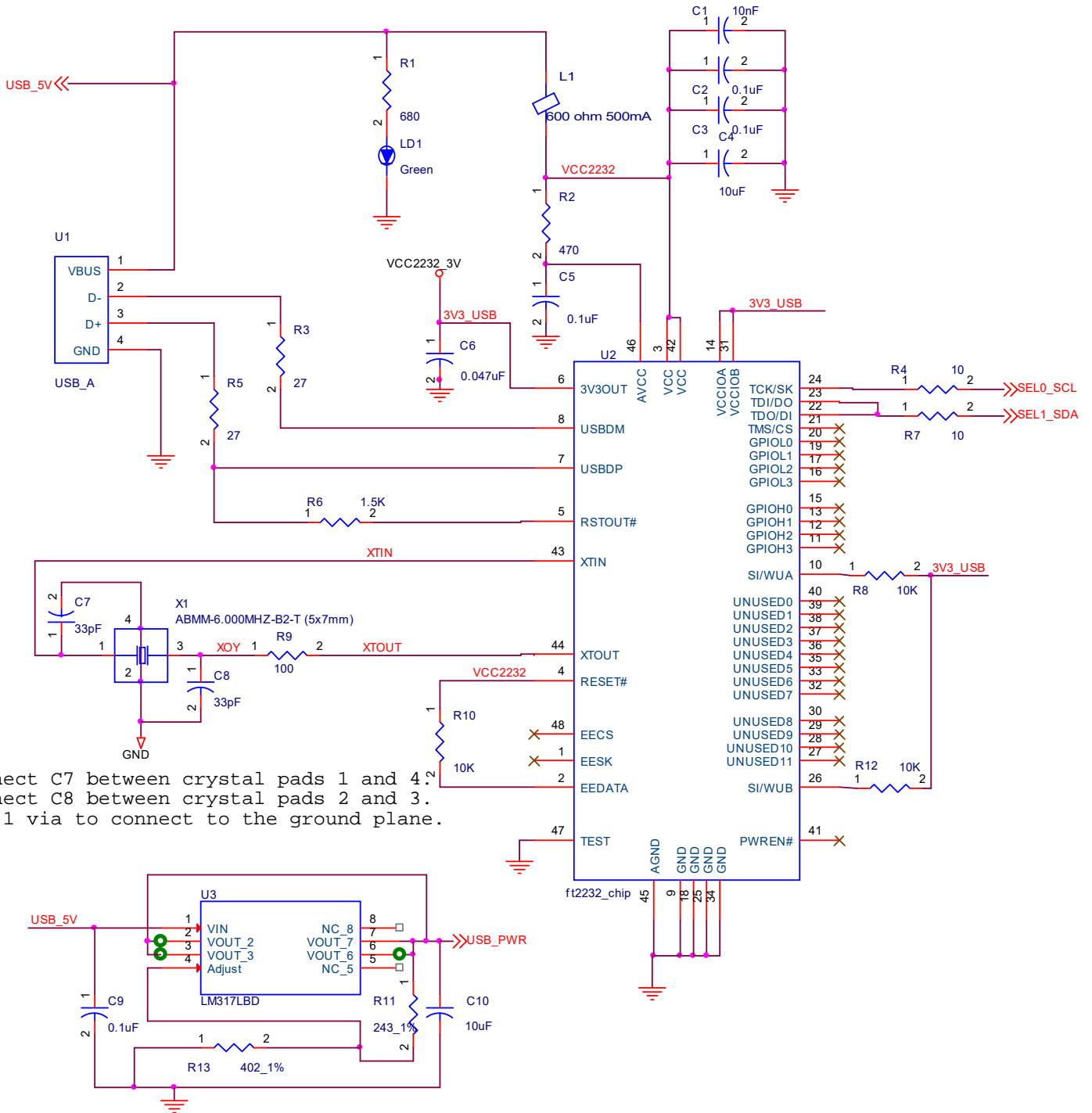

Figure 12. 5P49V6965/6975 Programmer Board Schematics - page 2



Ordering Information

Orderable Part Number	Description
5P49V6965-PROG	VC6E Programmer Board + 5P49V6965A000 samples
5P49V6975-PROG	VC6E Programmer Board + 5P49V6965A000 samples

Revision History

Revision Date	Description of Change
June 17, 2019	Initial release.

IMPORTANT NOTICE AND DISCLAIMER

RENESAS ELECTRONICS CORPORATION AND ITS SUBSIDIARIES (“RENESAS”) PROVIDES TECHNICAL SPECIFICATIONS AND RELIABILITY DATA (INCLUDING DATASHEETS), DESIGN RESOURCES (INCLUDING REFERENCE DESIGNS), APPLICATION OR OTHER DESIGN ADVICE, WEB TOOLS, SAFETY INFORMATION, AND OTHER RESOURCES “AS IS” AND WITH ALL FAULTS, AND DISCLAIMS ALL WARRANTIES, EXPRESS OR IMPLIED, INCLUDING, WITHOUT LIMITATION, ANY IMPLIED WARRANTIES OF MERCHANTABILITY, FITNESS FOR A PARTICULAR PURPOSE, OR NON-INFRINGEMENT OF THIRD-PARTY INTELLECTUAL PROPERTY RIGHTS.

These resources are intended for developers who are designing with Renesas products. You are solely responsible for (1) selecting the appropriate products for your application, (2) designing, validating, and testing your application, and (3) ensuring your application meets applicable standards, and any other safety, security, or other requirements. These resources are subject to change without notice. Renesas grants you permission to use these resources only to develop an application that uses Renesas products. Other reproduction or use of these resources is strictly prohibited. No license is granted to any other Renesas intellectual property or to any third-party intellectual property. Renesas disclaims responsibility for, and you will fully indemnify Renesas and its representatives against, any claims, damages, costs, losses, or liabilities arising from your use of these resources. Renesas' products are provided only subject to Renesas' Terms and Conditions of Sale or other applicable terms agreed to in writing. No use of any Renesas resources expands or otherwise alters any applicable warranties or warranty disclaimers for these products.

(Disclaimer Rev.1.01 Jan 2024)

Corporate Headquarters

TOYOSU FORESIA, 3-2-24 Toyosu,
Koto-ku, Tokyo 135-0061, Japan
www.renesas.com

Trademarks

Renesas and the Renesas logo are trademarks of Renesas Electronics Corporation. All trademarks and registered trademarks are the property of their respective owners.

Contact Information

For further information on a product, technology, the most up-to-date version of a document, or your nearest sales office, please visit www.renesas.com/contact-us/.