

Specialty Memory Products

IDT's multi-port memory portfolio includes more than 120 types of asynchronous and synchronous dual-ports, four-ports and bank-switchable dual-ports.

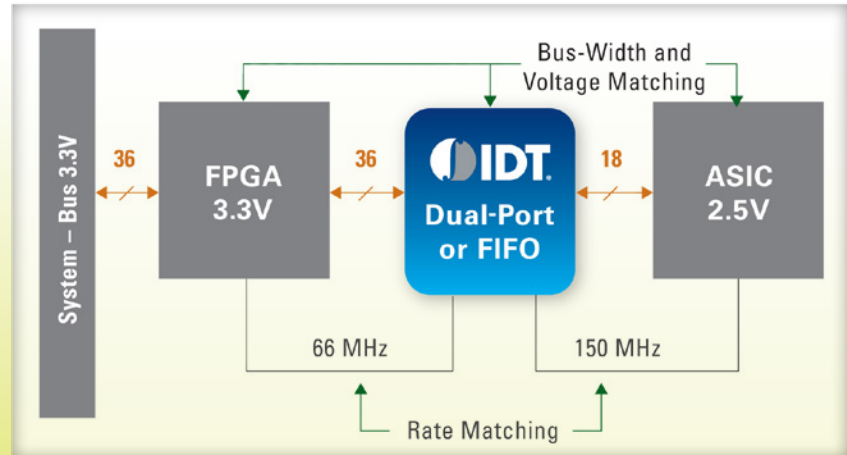

MULTI-PORT MEMORY BENEFITS

- Increases bandwidth (~2x SRAM)
- Reduces design complexity by solving inter-chip connection issues
- Solves bus matching issues from x8, x9, x16, x18, x36 up to x72 bit bus widths
- Allows mismatched voltage parts to be used together. 1.8, 2.5, 3.3 and 5V I/O's can be adapted
- Buffers bus speed mismatch from DC to 200 MHz
- Densities range from 8 Kb up to 36 Mb allowing a wide range of applications
- Improves time-to-market by using proven off-the-shelf devices

Multi-port Memories

IDT is the world leader in specialty memory with a dominant market position, a long history of innovation, and best-in-class support for FIFO and multi-port products. With hundreds of products and thousands of customers, IDT continues to provide the highest quality, fastest, and most diverse line of specialty memory in the industry.

The IDT multi-port memories portfolio includes more than 120 types of asynchronous and synchronous dual-ports, four-ports and bank-switchable dual-ports. These multi-port memory devices

are ideal for switches, routers, hubs, industrial equipment, fibre channel line cards and RAID controllers.

Our family of dual-port memories are the industry standard, with innovative features and speeds that provide superior value and performance to system level designs. IDT strives to reduce the cost of high performance shared SRAM based dual-port memory solutions. We are and will continue to be the leading provider of Dual-Port synchronous and asynchronous memories in the semiconductor industry.

Specialty Memory Products

MULTI-PORT PRODUCT FAMILY

Asynchronous Dual-Port RAMs

An asynchronous dual-port is a memory with non-clocked inputs and outputs for data, address, and control functions.

Bank-Switchable Dual-Port RAMs

IDT synchronous bank-switchable dual-ported RAMs offer increased density, while retaining many of the features of true dual-ports including access to the shared array, separate clocks per port, 200 MHz operating speed, full-boundary counters, and pinouts compatible to the dual-port family.

FourPort RAMs

IDT four-port RAMs are cost-effective low-power multiports that provide maximum functionality while taking up minimum board space to address the needs of high-end multimedia handset applications.

Synchronous Dual-Port RAMs

IDT synchronous dual-port RAM memory cells allow access to simultaneous access of address from both ports.

Asynchronous Low-Power Dual-Port RAMs

IDT low-power dual-ports simplify the design process for hand held devices. IDT LPDPs provide exceptionally low power consumption and the ability to buffer voltage, speed, and bus width mismatch between processors.

TYPICAL MULTI-PORT APPLICATION BLOCK DIAGRAMS

Storage Area Network

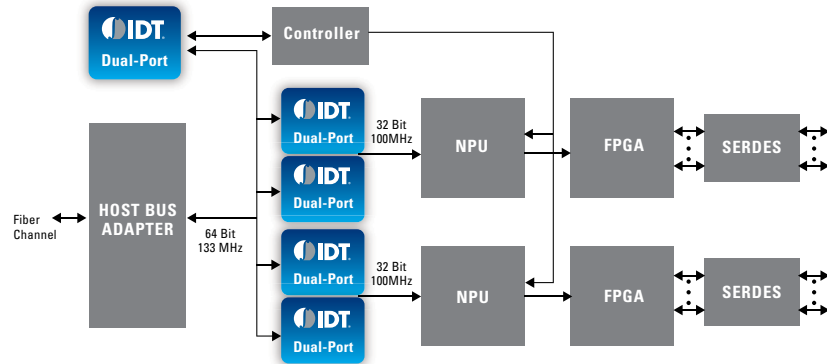

Data Acquisition

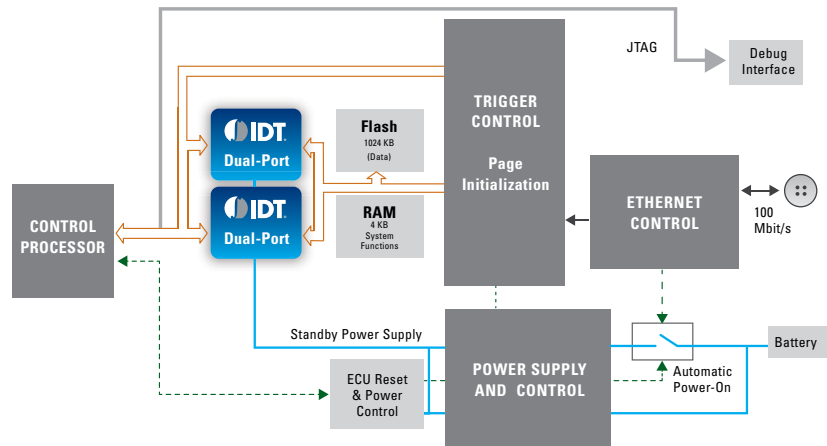

MULTI-PORT END APPLICATIONS INCLUDE

- Flight control | Video conference system | Sonar | Gas sensor
- Semiconductor equipment | Aircraft mission recorder
- PC for railway system | Industrial robot | Motor drive controller



Specialty Memory Products

FIFO PRODUCT FAMILY

Asynchronous FIFOs

IDT asynchronous FIFOs are a form of memory with separate strobes for reading and writing. When used to buffer data transmissions, they permit processing of data to proceed before the transmission has completed. They do this by preventing data overflow and underflow using logic to allow for unlimited expansion capability in both word size and depth.

Bi-Directional FIFOs

IDT bi-directional FIFOs can transfer data in two directions, enabling optimized inter-processor and inter-DSP communication. To achieve the bi-directional transfer capability, especially useful in communication network equipment. The highly integrated devices provide two side-by-side FIFO memory arrays. They accelerate cycle times, reduce board space and allow more efficient bus utilization.

Queuing FIFOs

The IDT FIFO Multi-Queue device is a fully programmable device, providing the user with flexibility in how queues are configured.

Synchronous FIFOs

IDT synchronous FIFOs are particularly appropriate for network, video, telecommunications, data communications and other applications that need to buffer large amounts of data.

FIFO PRODUCTS

IDT is the FIFO market leader with more than 170 synchronous, asynchronous and bi-directional products to help designers solve interchip communications problems, such as rate matching, buffering and bus matching.

TYPICAL FIFO APPLICATION BLOCK DIAGRAMS

Test Equipment Application

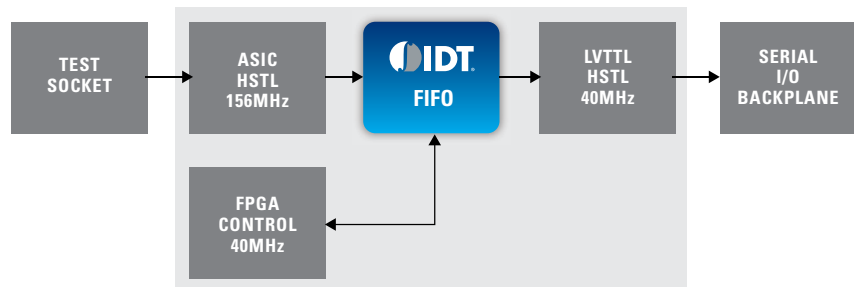

Data Buffering: High Bandwidth LineCards

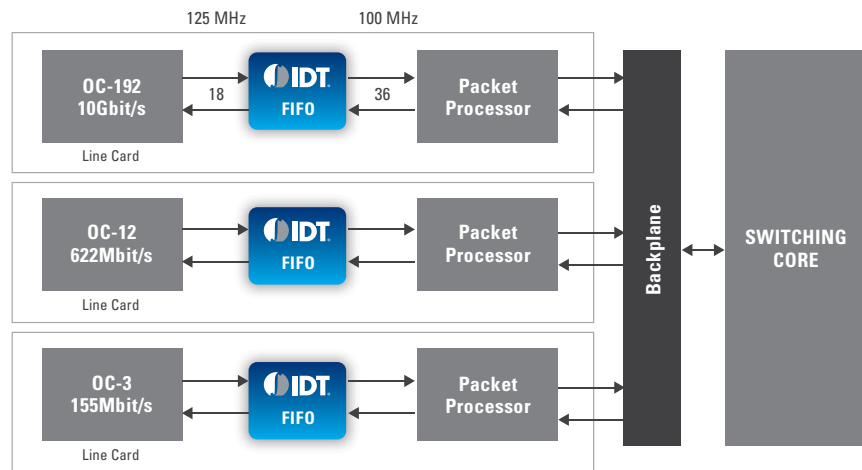

FIFO END APPLICATIONS INCLUDE

Medical recorder | Repeater | Ultrasound | Densitometer | Surgical instrument
ATM | Electroencephalograph | Cell phone tester | Commercial avionics | Printer



Specialty Memory Products

SRAM BENEFITS

- A wide range of products from 16-Kbit to 18-Mbit densities
- Synchronous and asynchronous architectures
- IDT invented ZBT technology, the communications SRAM standard

SRAM

ASYNCHRONOUS SRAMS | SYNCHRONOUS BURST SRAMS | ZERO BUS TURNAROUND (ZBT) SRAMS

In addition to our FIFOs and Multi-ports, IDT offers a line of high-speed, industry-standard SRAMs that are used in communications, industrial and military markets. IDT has been in the SRAM business for more than 35 years with a track record of consistent, innovative, high-quality products.

SPECIALTY MEMORY END APPLICATIONS

Industrial controls | Medical applications | Elevator controls
Brewery controls | Robotic welding

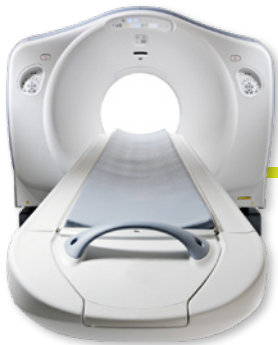

To request samples, download documentation or learn more visit: idt.com