

# 8V97053 / 8V97053L High Performance RF Synthesizers / PLLs

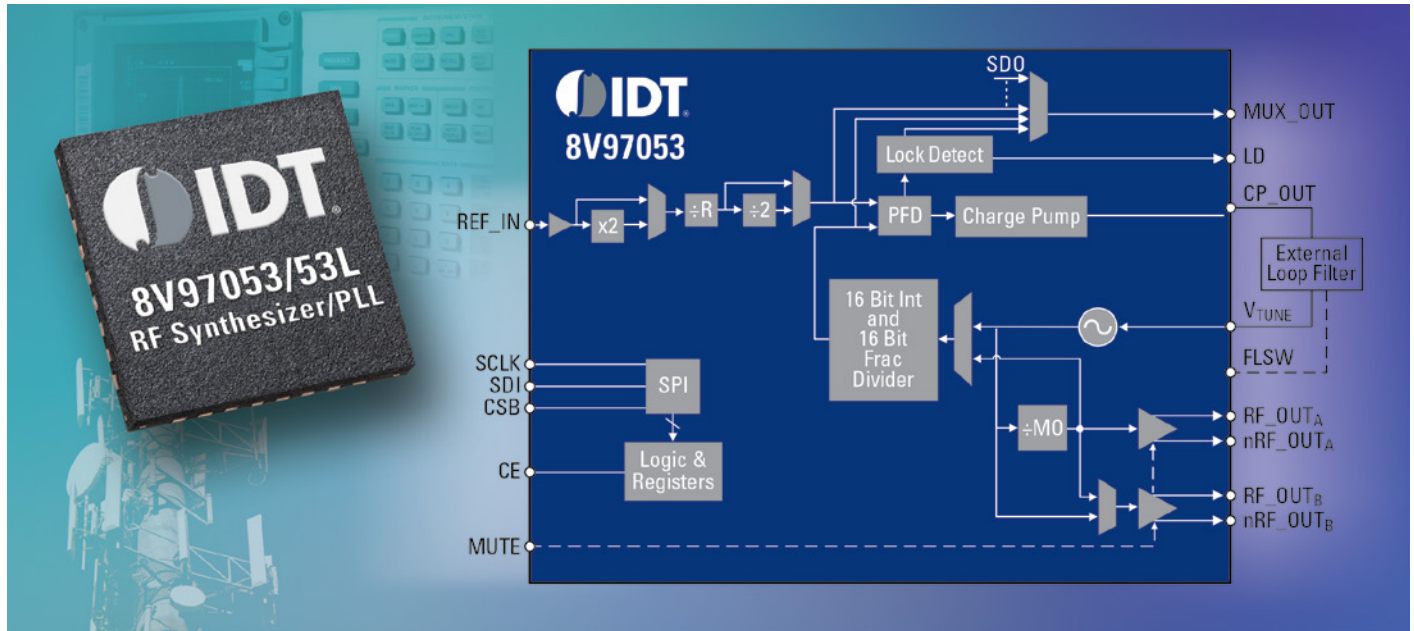

## FEATURES

- GSM-grade wideband RF synthesizer / PLL
- Generate frequencies from 34.375MHz to 4.4GHz
- Excellent phase noise performance
  - 148.7dBc/Hz at a 1MHz offset for a 745MHz output
  - 142.2dBc/Hz at a 1MHz offset for a 1.65GHz output
- Excellent spurious performance including integer boundary spurs
- 5 × 5 mm 32-VFQFN package
- Pin-compatible to similar devices from other manufacturers as well as the IDT 8V97051

## TARGET MARKETS/APPLICATIONS

Base stations (including GSM radio cards)  
Distributed antenna systems  
Instrumentation  
Microwave point-to-point  
Radar

The 8V97053 and 8V97053L RF synthesizers / PLLs with integrated VCO offer an industry-leading combination of high performance, low spurious noise, low power consumption and wide tuning range.

These devices offer an integrated voltage controlled oscillator (VCO) with a large tuning range capable of providing multi-band local oscillator (LO) frequency synthesis, limiting the need for multiple narrow band RF synthesizers / PLLs. This reduces the bill of materials and the design complexity, lowering the cost of developing radio frequency products. The devices address the challenges of frequency generation for high-performance mixers and demodulators in RF board designs; or for high performance RF converter clocking.

The products offer low power consumption that is ideal for high-performance applications with limited or no air flow, such as RF cards in base stations, or for applications powered over Ethernet and portable instrumentation.

In addition to offering low phase noise, the devices provide 16 bits of frequency resolution that make them ideal for precise RF instrumentation or radar applications. These devices can also be used in microwave transceivers and industrial electronic products. Extended registers allow for additional resolution and features for further control of the LO function.

In addition to the features and performance of the 8V97053, the 8V97053L also offers higher performance on-chip Low Dropout regulators (LDOs), further reducing power supply complexity and cost.

To request samples, download documentation, or learn more, visit:  
[idt.com/go/RF-Synth](http://idt.com/go/RF-Synth)