

DA4100 WattUp® Wireless Power Transmitter

Highly integrated wireless power transmitter enables WattUp wire-free RF/antenna-based charging

DA4100 is a highly integrated RF transmitter System-on-Chip designed to provide optimal charging of WattUp receiver devices. It forms the core of the Near Field WattUp transmitter system and is designed to charge a range of devices fitted with WattUp receivers. It features the RF transmitter, power management and integrated DC-DC, delivering a complete WattUp transmitter system solution. Applications include the wireless charging of low-power, battery-powered devices, such as wearables, fitness trackers, hearables, hearing aids, Bluetooth trackers, smart pens and other devices.

WattUp® from Energous Corporation is a radio frequency (RF) based wireless charging solution that delivers intelligent, scalable power. WattUp technology is provided to Dialog under license from Energous Corporation. The Near Field WattUp transmitter design is intended to be an in-box solution for many small electronics, ultimately replacing the USB cable and power adapter typically included in the box. The WattUp receiver provides the convenience and waterproofing benefits of wireless charging without significantly affecting the overall BOM cost. The Near Field WattUp transmitter technology can be embedded into laptops, game consoles, furniture, automotive, other devices or as a stand-alone transmitter.

DA4100 integrates most of the functions required to form a complete WattUp transmitter system including an ARM Cortex® M0+ processor, RAM, ROM, crystal oscillator, Low Profile Oscillator (LPO), clock divider, Phase-Lock Loop (PLL), RF converter, Variable Gain Amplifier (VGA), Power Detectors (PD), DC-DC, LDO's, I2C, UART, SPI, GPIOs, ADCs and DACs. The device only requires an external crystal and power amplifier and operates directly from 3.3V power supply.

WattUp DA4100 Wireless Power Transmitter Block Diagram

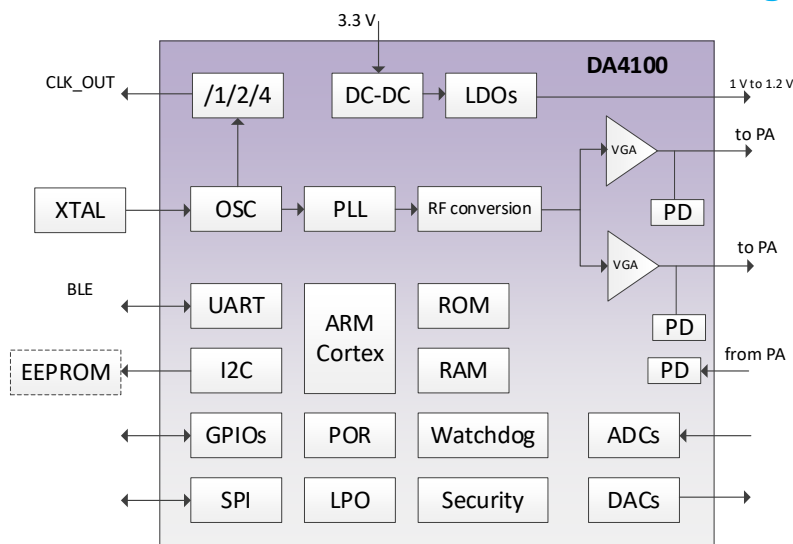

Near Field WattUp System

The Near Field WattUp system is comprised of a WattUp wireless power transmitter (DA4100), a WattUp wireless power amplifier (DA3210), a WattUp wireless power receiver (DA2210 or DA2223), a DC regulator, a Li-Ion/Li-Poly battery charger and an optional Bluetooth communication link (DA14680, DA14681 or DA14585) which supports battery status communication between the WattUp receiver and transmitter. The same link can be used to provide the user with full power management capabilities using the WattUp Application running on a Smartphone or tablet. Antennas are fabricated using low-cost PCB material, flexible PCB or sheet metal.

Near Field WattUp System Block Diagram

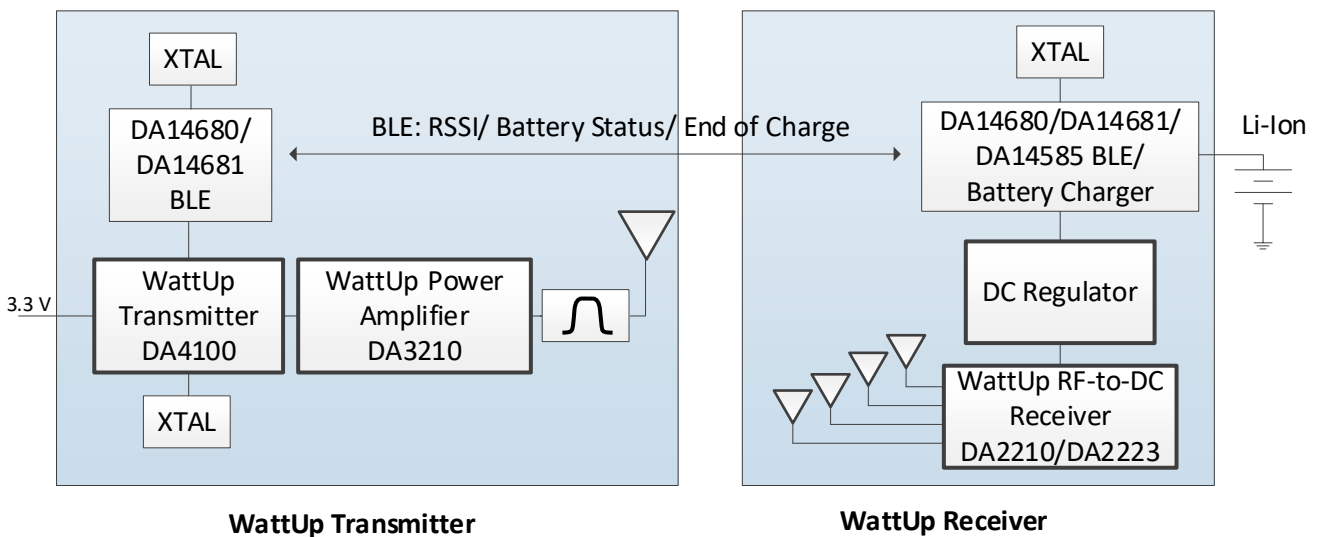

Applications

- Fitness Bands
- Hearables
- Hearing Aids
- Bluetooth Headsets
- Bluetooth Trackers
- Smart Pens
- Remote Controls
- Smart Glasses

Key benefits

- Ultra-small RF/antenna-based solution
- Improved spatial and orientation freedom
- Secure pairing of the transmitter and device-under-charge
- Eliminates connectors and charging contacts
- Enables fully sealed waterproof design

Dialog Semiconductor Worldwide Sales Offices - www.dialog-semiconductor.com email: enquiry@diasemi.com

United Kingdom Phone: +44 1793 757700	The Netherlands Phone: +31 73 640 8822	Japan Phone: +81 3 5769 5100	Singapore Phone: +65 648 499 29	Korea Phone: +82 2 3469 8200
Germany Phone: +49 7021 805-0	North America Phone: +1 408 845 8500	Taiwan Phone: +886 281 786 222	Hong Kong Phone: +852 2607 4271	China (Shenzhen) Phone: +86 755 2981 3669
				China (Shanghai) Phone: +86 21 5424 9058

This publication is issued to provide outline information only, which unless agreed by Dialog Semiconductor may not be used, applied, or reproduced for any purpose or be regarded as a representation relating to products. All use of Dialog Semiconductor products, software and applications referred to in this document are subject to Dialog Semiconductor's [Standard Terms and Conditions of Sale](#), available on the company website (www.dialog-semiconductor.com) unless otherwise stated.

Dialog and the Dialog logo are trademarks of Dialog Semiconductor plc or its subsidiaries. All other product or service names are the property of their respective owners.

© Copyright 2019 Dialog Semiconductor. All rights reserved.