

# DTDS

## RX Ecosystem Partner Solution

# DTDS Inverter Fridge Solution



### Solution Summary

DTDS cost effective, high-voltage (HV) inverter fridge board is a production-ready solution supporting compressor control for home appliance and industrial refrigeration applications with the [RX13T](#) MCU. The inverter fridge driver board design is optimized for minimum component count and low cost, and reducing time to market for refrigerator designs. Motor control and system tuning software are provided to help customers optimize their systems. Smart failure prediction with AI can be implemented upon request.

### Features/Benefits

- Sensorless field-oriented control (FOC)
- Fast ramp up and precision speed control
- Safety features – over voltage, over current, motor lock protection, under voltage protection

### Diagrams/Graphics

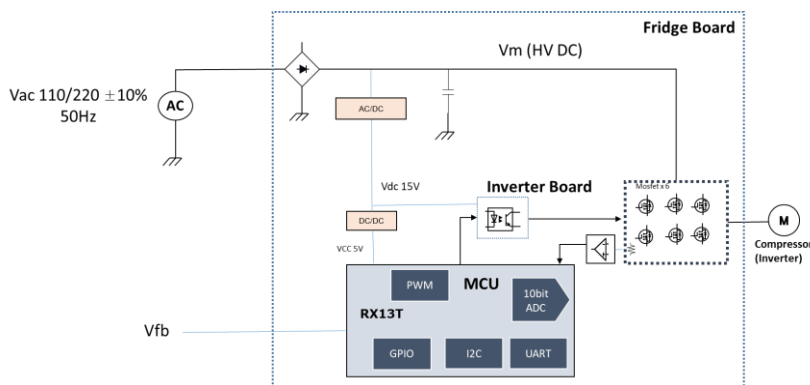

Vin	110/220 Vac±10% 50Hz
Max power out	<300W
Speed range	1000-4500 RPM
Load	Inverter compressor

### Target Markets and Applications

- Consumer refrigerator
- Inverter fridge
- Industrial freezer

[dtdsgp.com/dtds-inverter-fridge-driver](http://dtdsgp.com/dtds-inverter-fridge-driver)

# DTDS

DTDS group has diversified businesses in many verticals through its subsidiaries and associate organizations which focuses on the entire ecosystem in the electronics industry.

Primary focus areas are:

- Electronics components distribution
- Independent Design House (IDH)

DTDS Solution Team provide customize electronics design in the area of IoT, power management and renewable energy applications. Our design include LoRa module, temperature and humidity sensor, vibration sensor, smart water meter, and inverter motor control board

DTDS high voltage lab (HV Lab) in Singapore provides support for customer motor control requirements. DTDS HV lab equips with the necessary testing equipment like AC source, isolated HV current and voltage probe, oscilloscope for motor control and inverter testing.

Web: <https://dtdsgp.com/>

Contact: [enquiry.asean@dtdsgp.com](mailto:enquiry.asean@dtdsgp.com) or [Contact us](#)

Location: Asean/ India

