

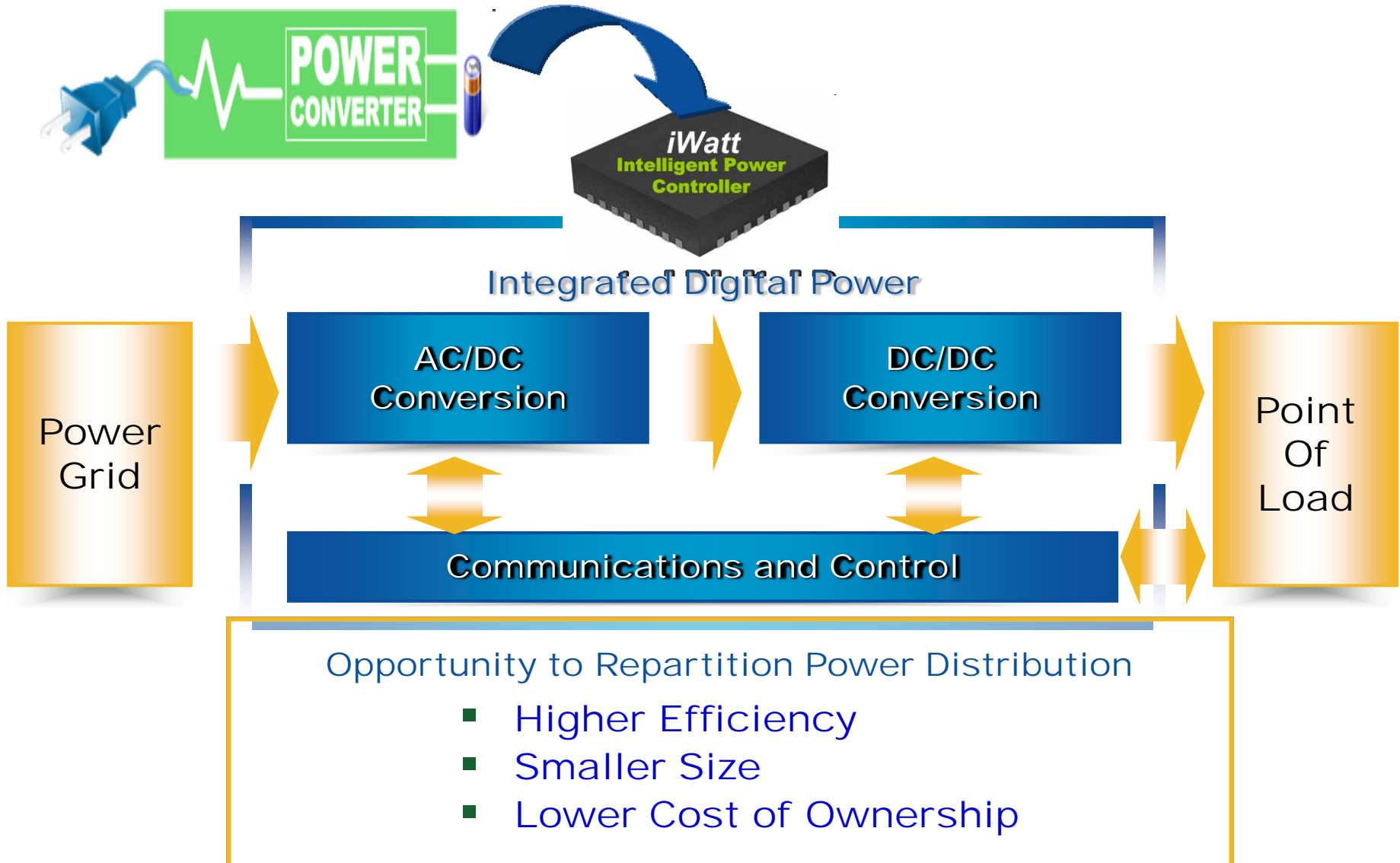

A Small-Size High-Efficiency Low-Cost Design with Digital Power Controller iW1691

iWatt Inc.
Los Gatos, CA 95032
USA

- Introduce iW1691
- Design example- A 5V2A adaptor design
- Summary



- **A US-based technology company, located in Silicon Valley**

- **The first company to release Digital Power Control IC's for ac/dc offline**
 - *iW1689, iW1692, iW1690, iW1696, iW1698, iW1691 & iW1710*
 - *LED offline drivers iW3620, iW3610*

- **Provides Total System Solutions for low-power adapters and chargers with low cost and high performance**
 - **Patented digital primary-feedback control technology with Tight CV regulation**
 - **Patented Constant Current (CC) regulation with primary-feedback**
 - **Advanced multi-layer fault protection technology**

■ Design For EMI

■ Design For Efficiency

- ❖ Quasi-resonant control
- ❖ High margin to meet EPA 2.0
- ❖ Flat efficiency curve cross line and load

■ Design for Green

- ❖ Low no_load power consumption

■ Adaptive Multi-Mode Operations

- ❖ PWM, PFM, Deep PFM,
- ❖ Build-in adaptive loop compensation

■ Fast Dynamic Response

- ❖ Adaptive digitalized Bang-bang mode control

■ Tight CC regulation

- ❖ Protect Cell phone internal charger
- ❖ Avoid overheat

■ Tight CV regulation

- ❖ +/-3% overall

■ Single Fault Protections

- ❖ Active OVP
- ❖ Active short circuit
- ❖ Current over shoot control
- ❖ Latch function: SD (OTP)

■ Cable drop compensation

■ Power application up to 25W

A Simple Application Schematic

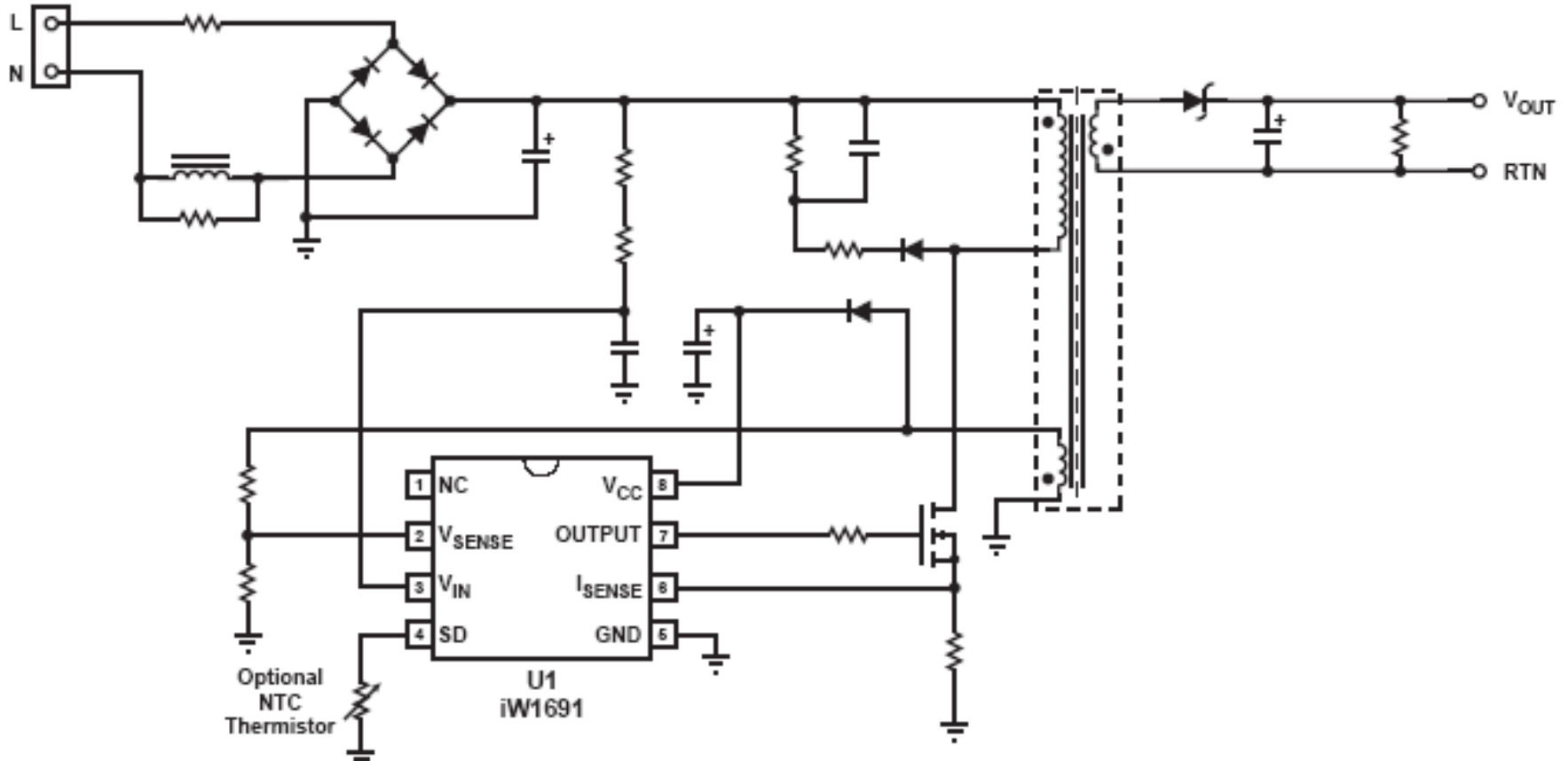

iW1691, 8-lead SOIC package

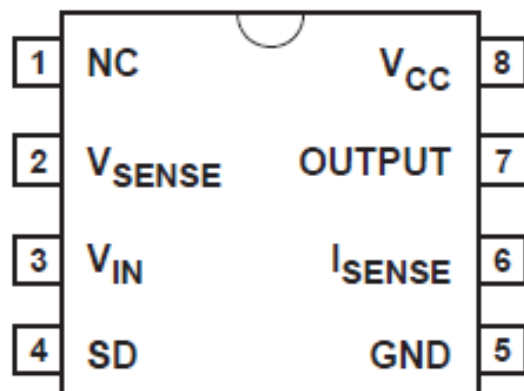

Soldering Temperature Resistance:

[a] Package is IPC/JEDEC Std 020D Moisture Sensitivity Level 1

[b] Package exceeds JEDEC Std No. 22-A111 for Solder Immersion Resistance; package can withstand 10s immersion < 270°

Pin #	Name	Type	Pin Description
1	NC	-	No connection.
2	V _{SENSE}	Analog Input	Auxiliary voltage sense (used for primary side regulation).
3	V _{IN}	Analog Input	Rectified AC line average voltage sense.
4	SD	Analog Input	External shutdown control. Connect to ground through a resistor if not used. (see section 10.16)
5	GND	Ground	Ground.
6	I _{SENSE}	Analog Input	Primary current sense (used for cycle-by-cycle peak current control and limit).
7	OUTPUT	Output	Gate drive for external MOSFET switch.
8	V _{CC}	Power Input	Power supply for control logic and voltage sense for power-on reset circuitry.

IC Block Diagram

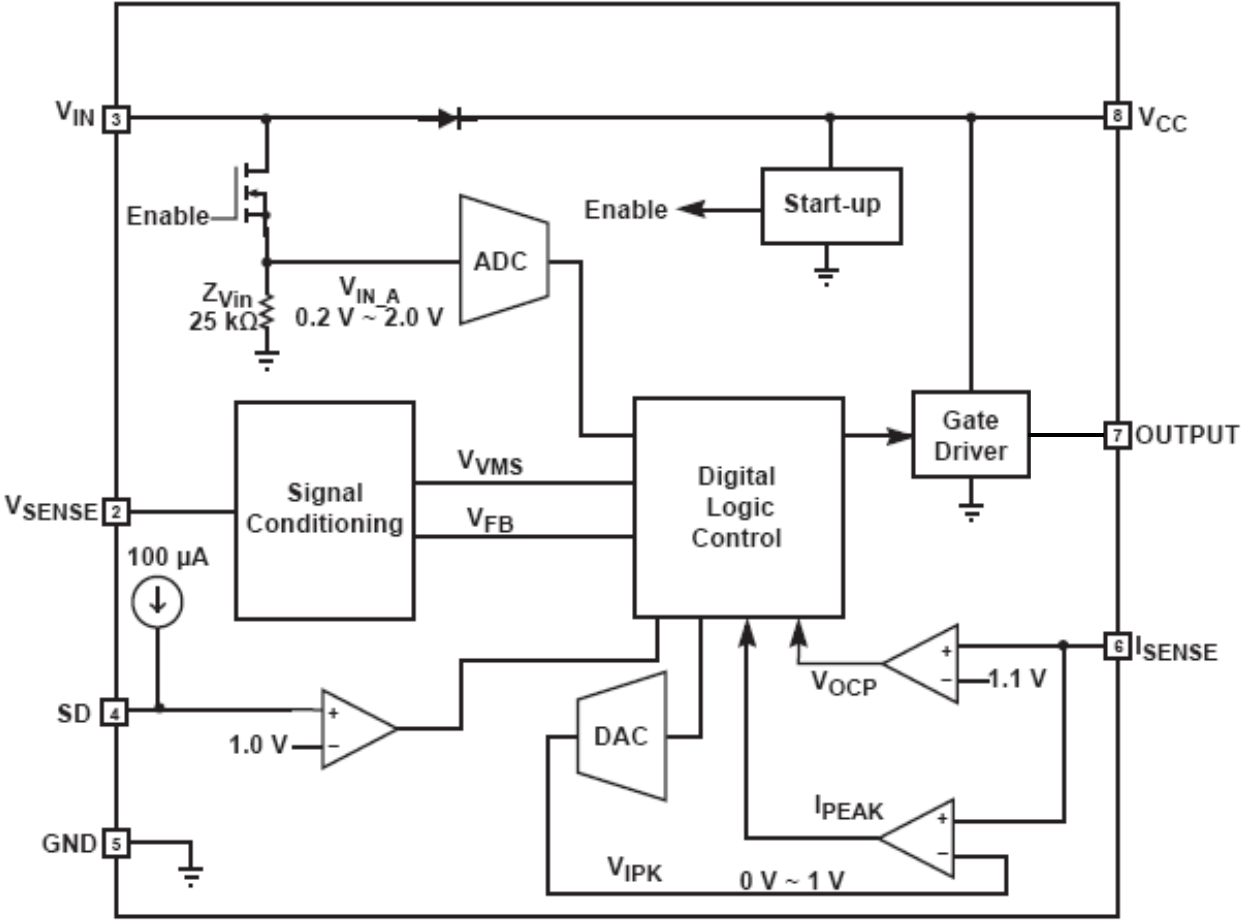

Intelligent Multi-Mode Operation

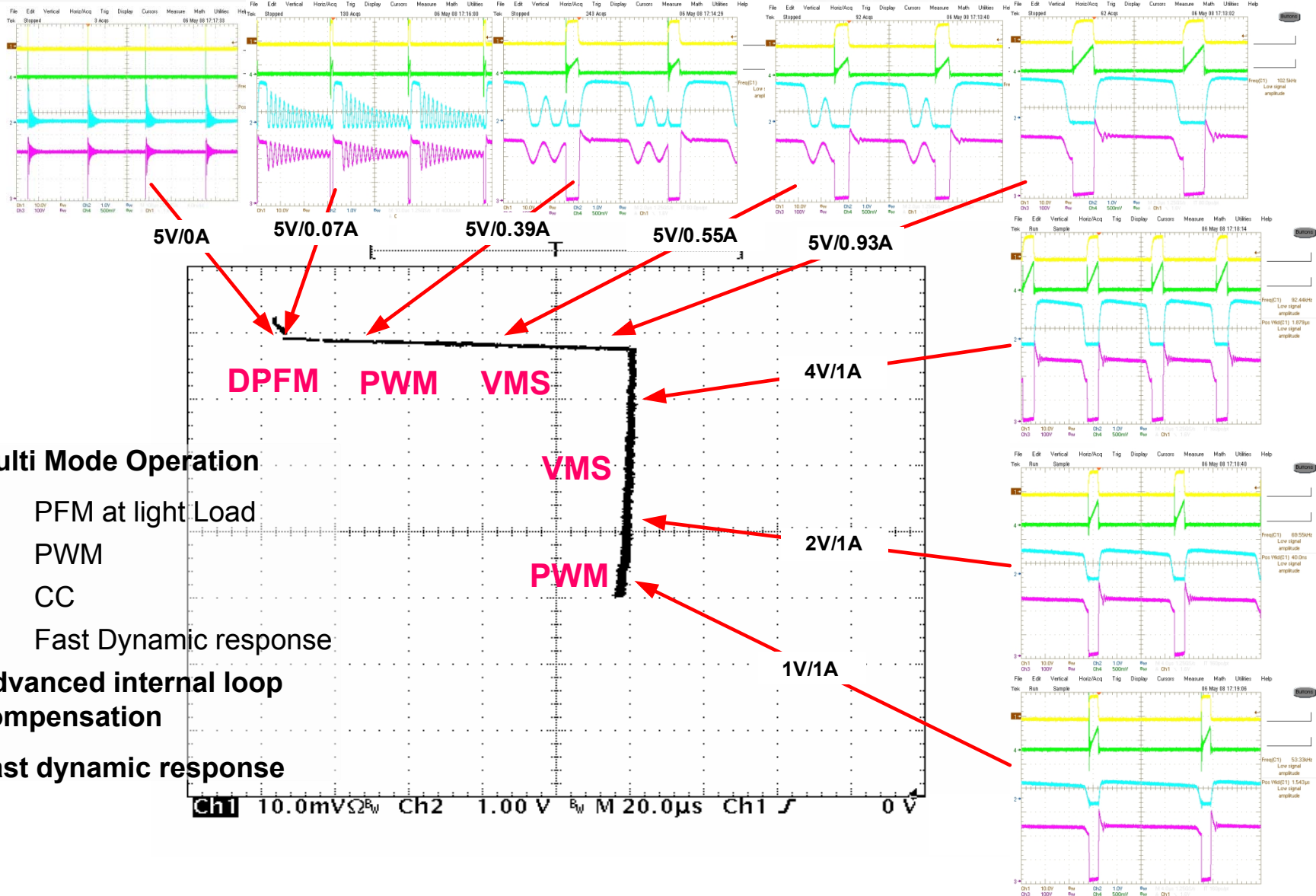

- **Multi Mode Operation**

- PFM at light Load
- PWM
- CC
- Fast Dynamic response

- **Advanced internal loop compensation**

- **Fast dynamic response**

80+ Efficiency Cross Line and Load

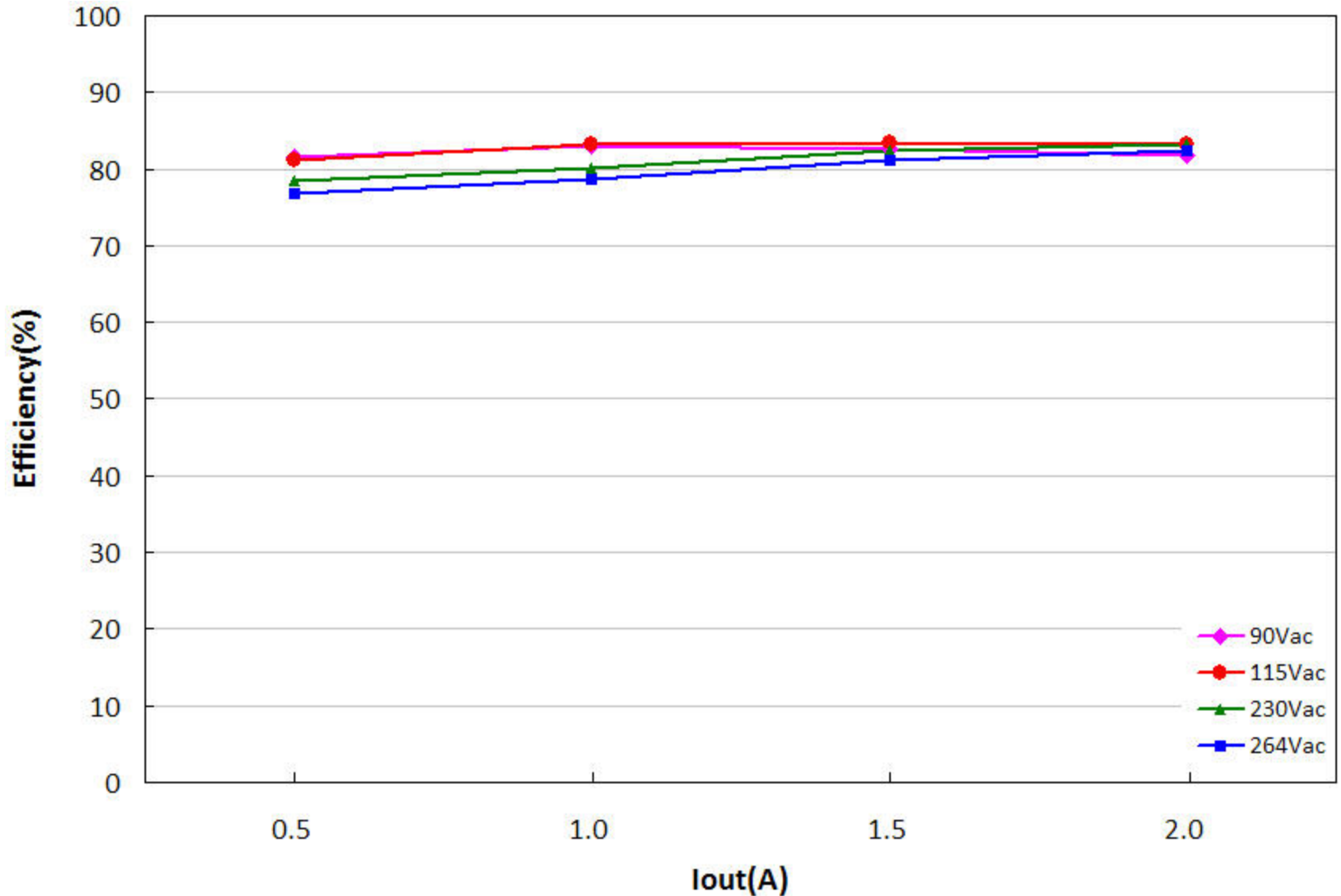

- Valley mode switching at CV heavy load (>45%)
- Valley mode switching at CC heavy load (Estimate>30%)
- Reduced switching frequency below 25% load
- Reduced switching frequency at high input voltage
- DPFM at light load

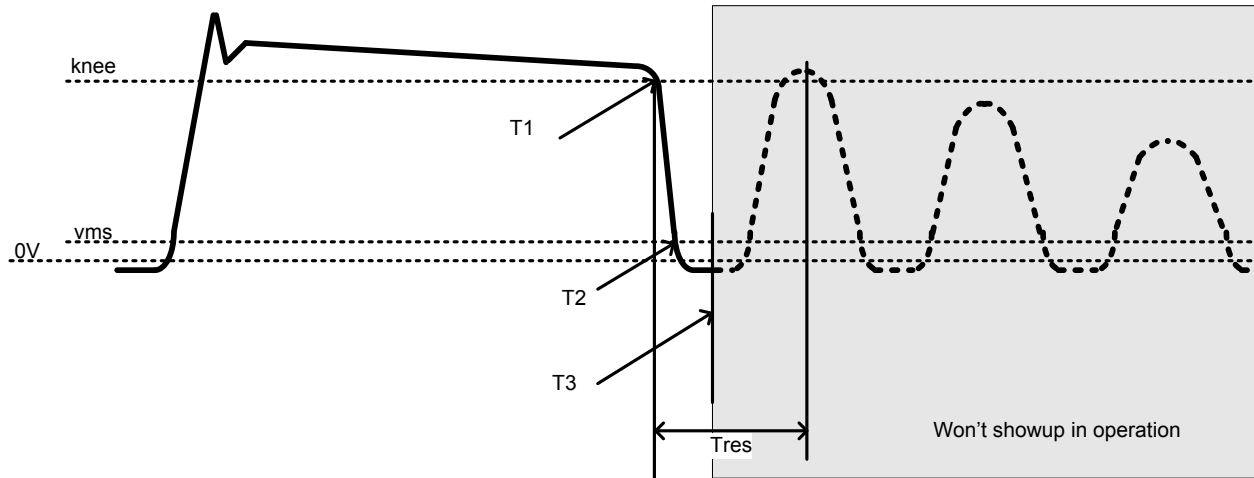

- The transformer resets at time T1.
- The magnetizing inductance L_m and the capacitance seen from drain of power switch starts resonance at period T_{res} . At time T3, the resonant voltage reaches the lowest position.
- If the switch turns on at T3 (so-called “quasi-resonant” or “valley mode” switching), the switching loss is minimized. Because of low dV/dt , the EMI can also be reduced comparing to the typical non-valley mode switching design.
- iWatt has successful experience on valley mode switching from previous design and research practice.

Patented Switching Frequency Map

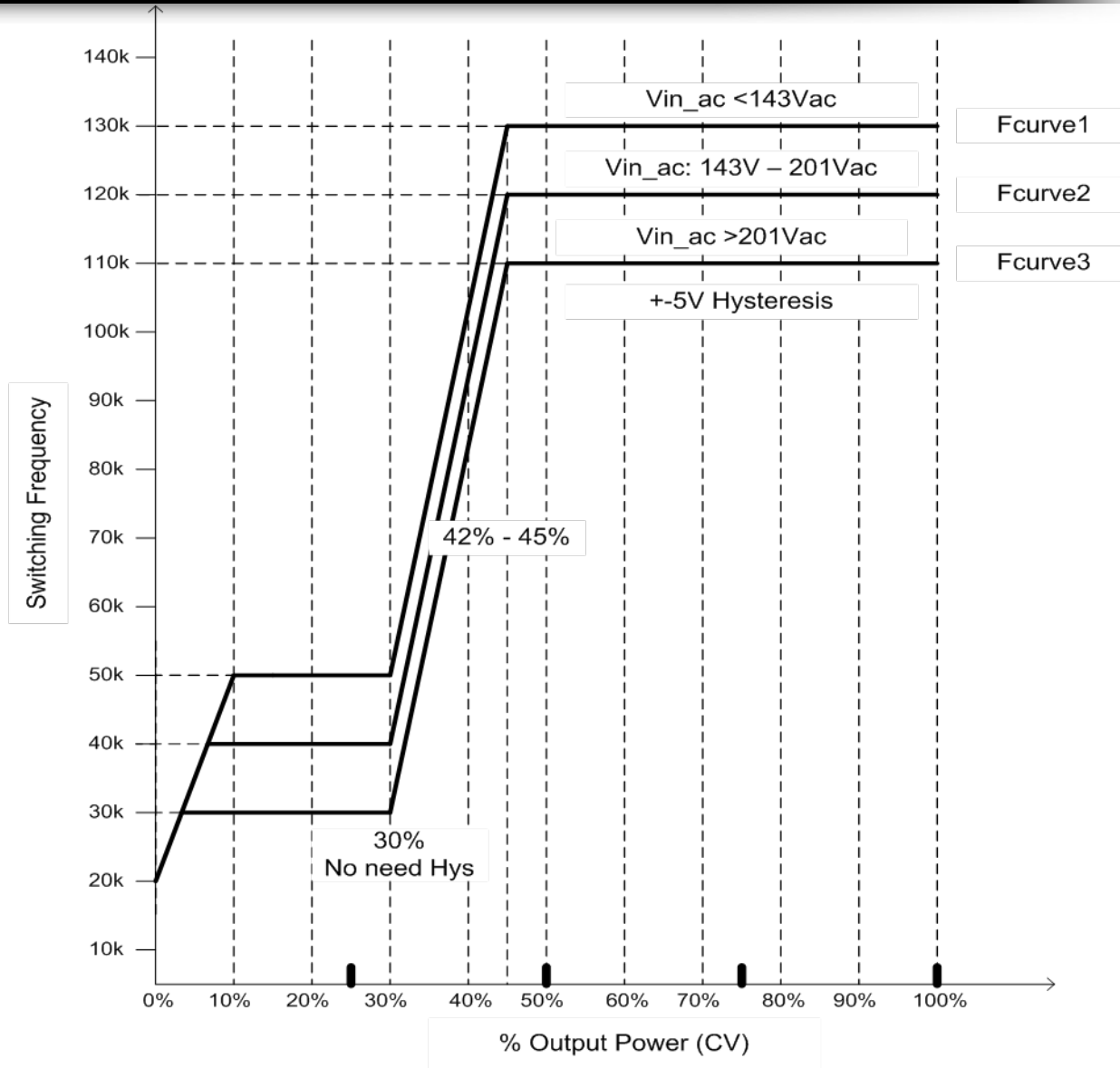

- Dynamic gate driver impedance to control the turn-on and turn-off speed
- Digitalized Frequency Spectrum Spread
- 130kHz maximum frequency limit
- Valley mode switching to reduce the turn-on spike

Dynamic Gate Drive Impedance

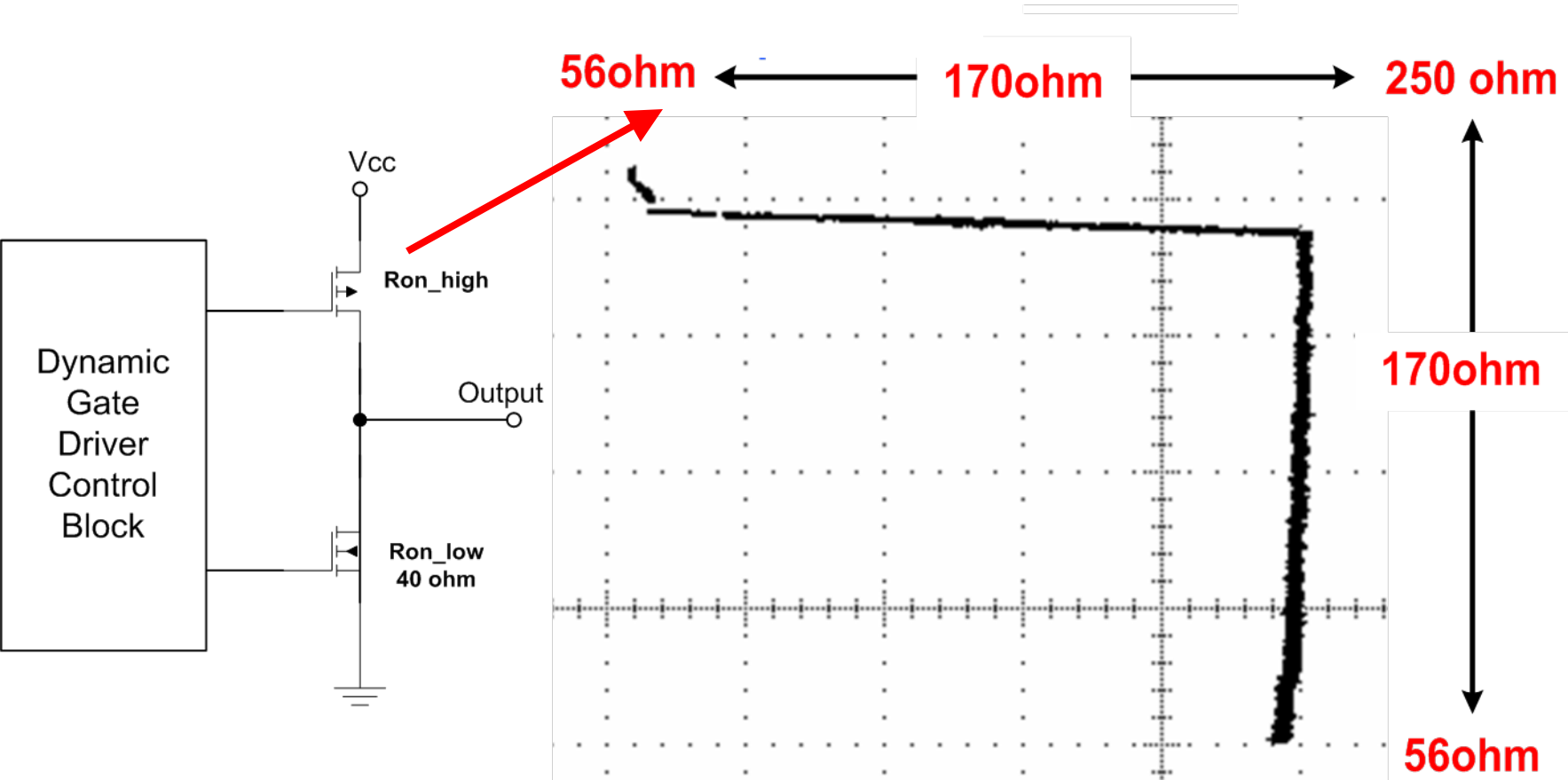

Conducted EMI Comparison

Traditional QR Solution

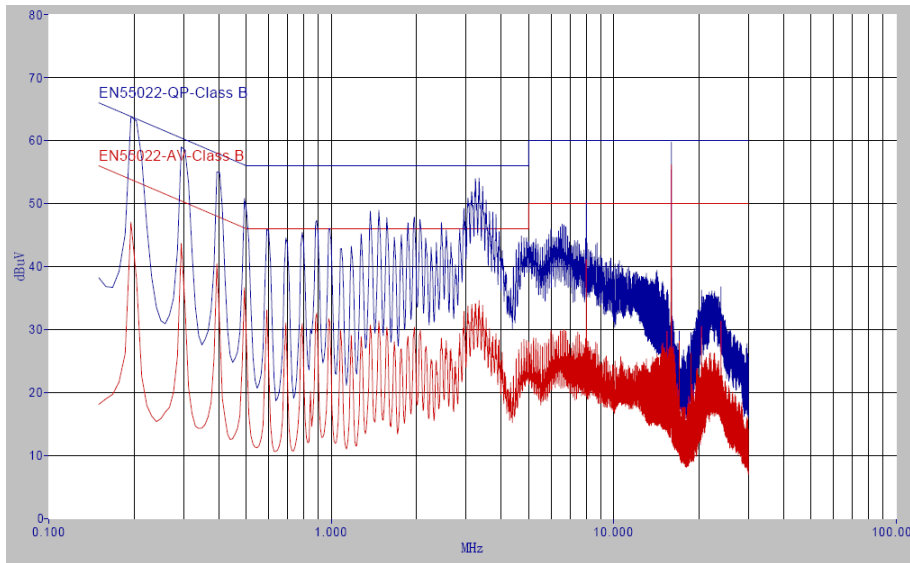

iW1691 Solution

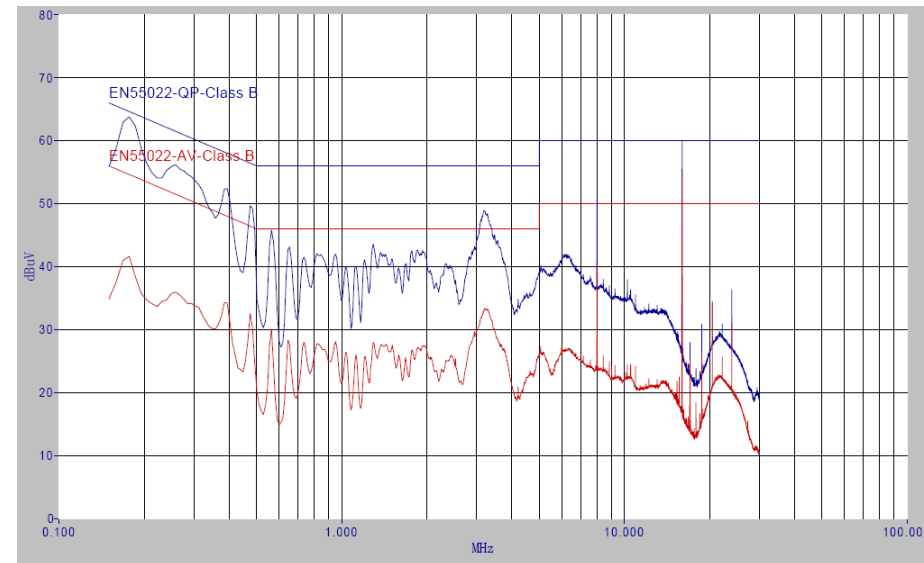

Adaptive Fast Load Transient Detection

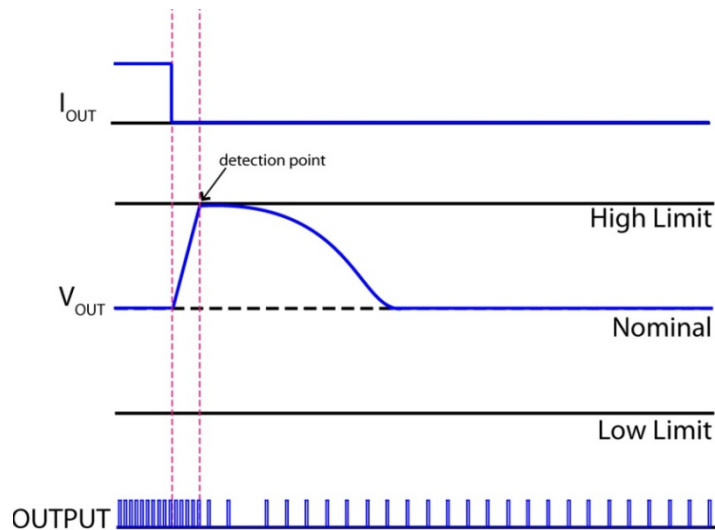

Heavy Load to Light Load

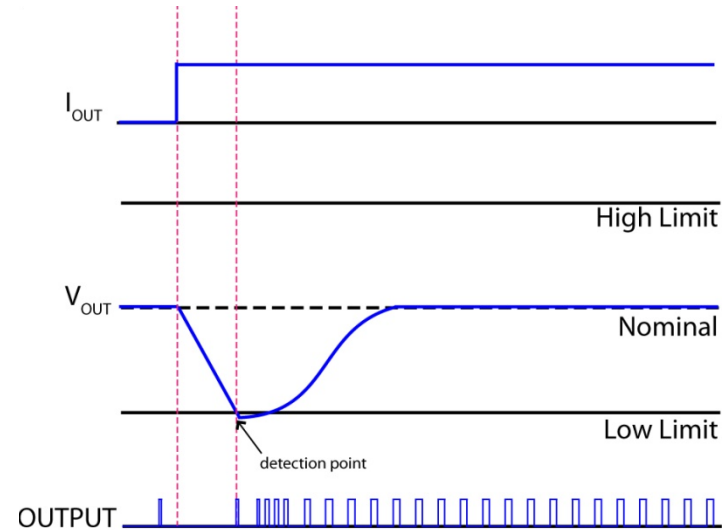

Light Load to Heavy Load

- Primary voltage feedback responds to the load change cycle-by-cycle
- A proprietary hysteresis control method to speed up the dynamic response in addition to the traditional Proportional-Integration-Differential (PID) control
- When the output voltage reaches the high limit, iW1691 increases the off-time immediately to reduce the output power; If the output voltage reaches the low limit. iW1691 increases the switching frequency immediately to quickly compensate for the output voltage drop.

Result From Fast Dynamic Response

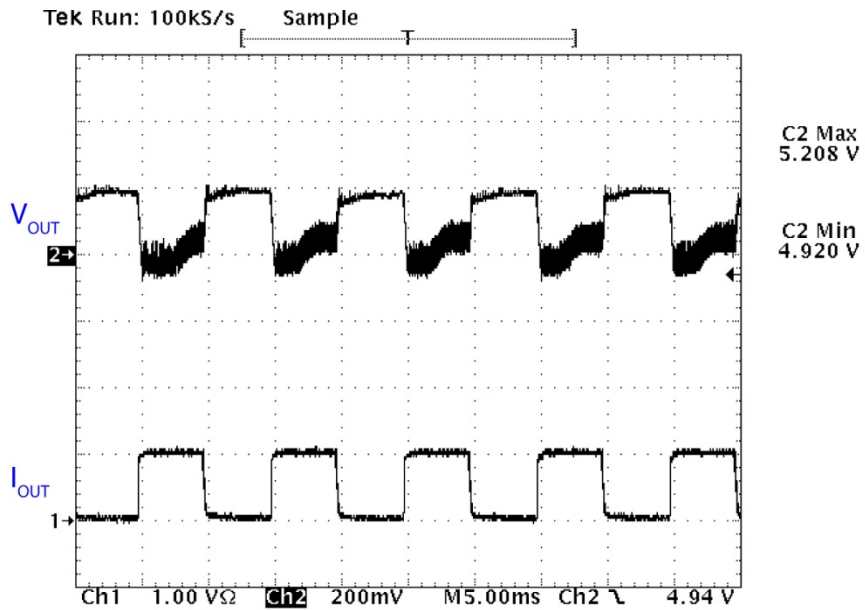

Load 0A - 1A - 0A

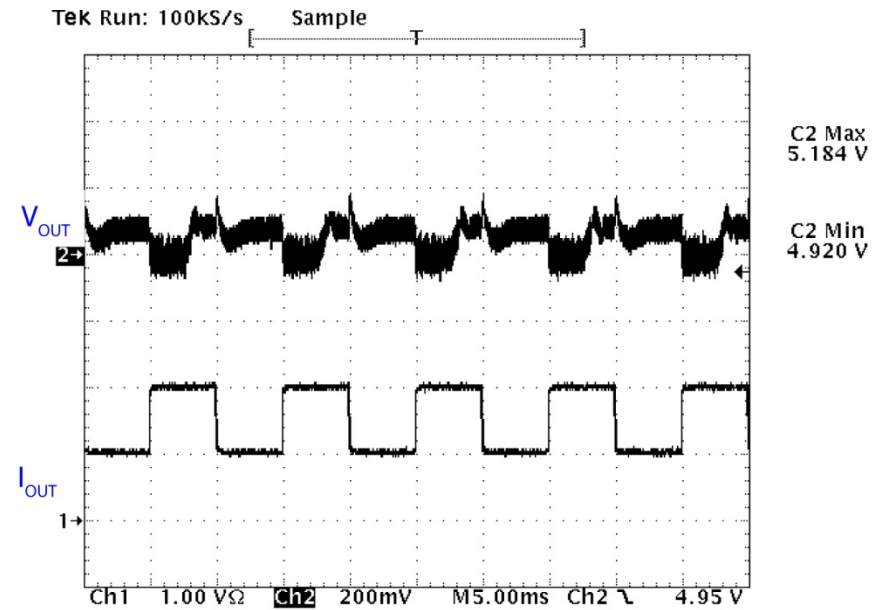

Load 1A - 2A - 1A

■ Low power management

- Increase system output stability in no load condition to allow high pre-load resistance.
- Put system into sleep mode in between the long output trains.

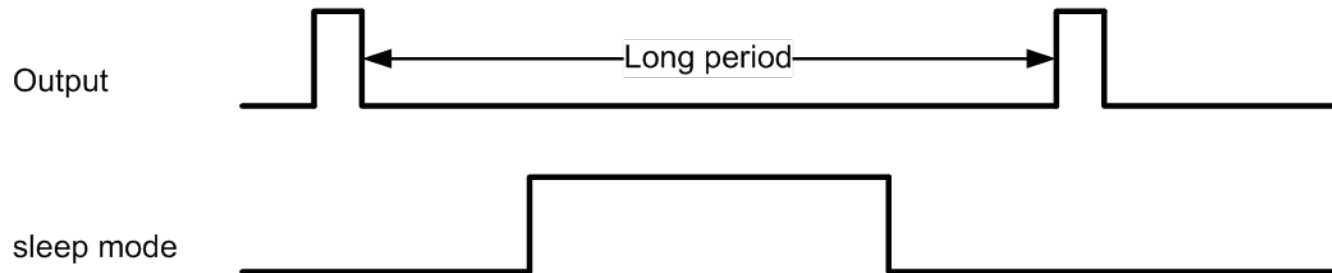

No-Load Standby Power Consumption

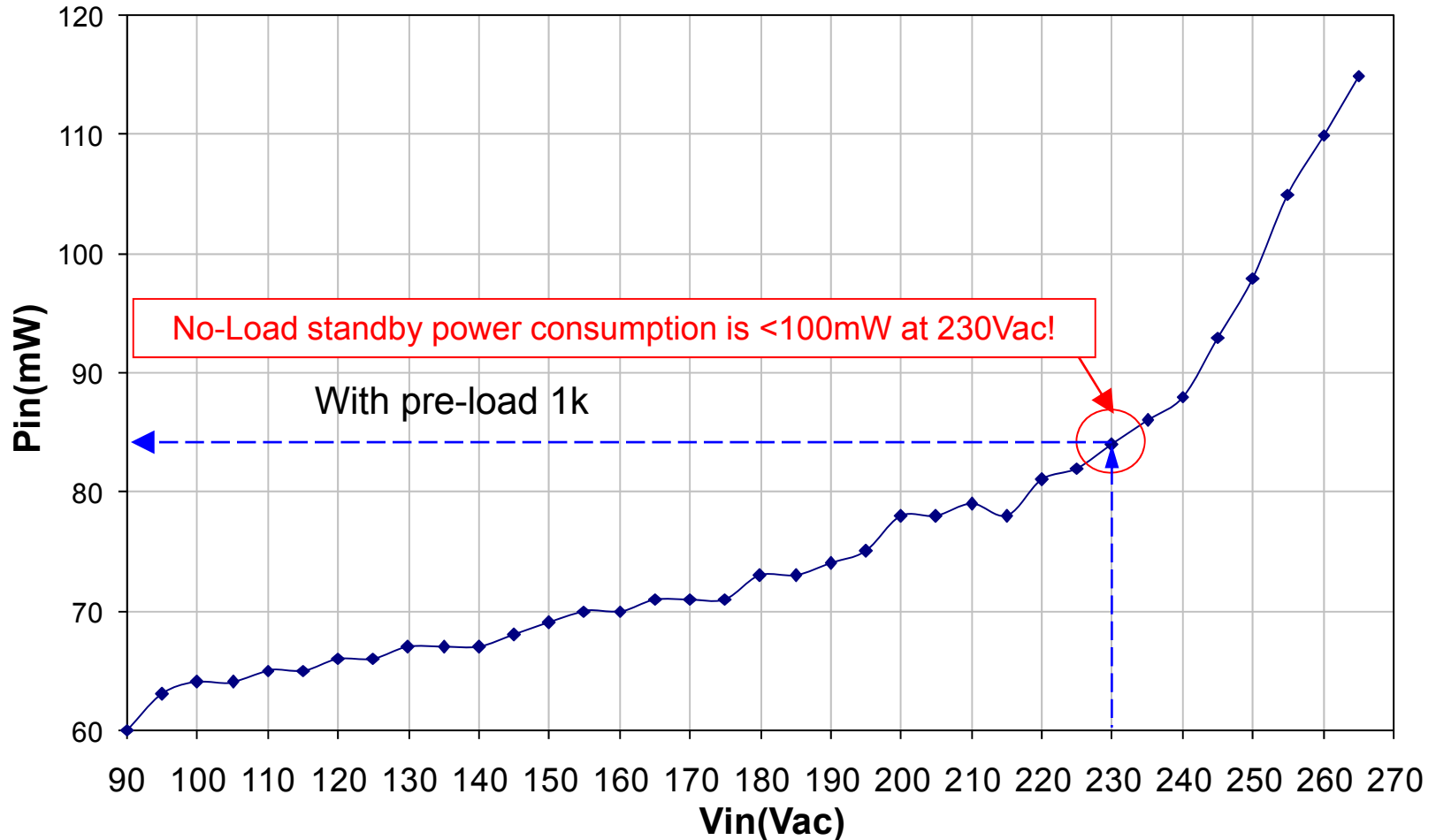

Cable Drop Compensation

1691 Cable Drop Compensation for 5V

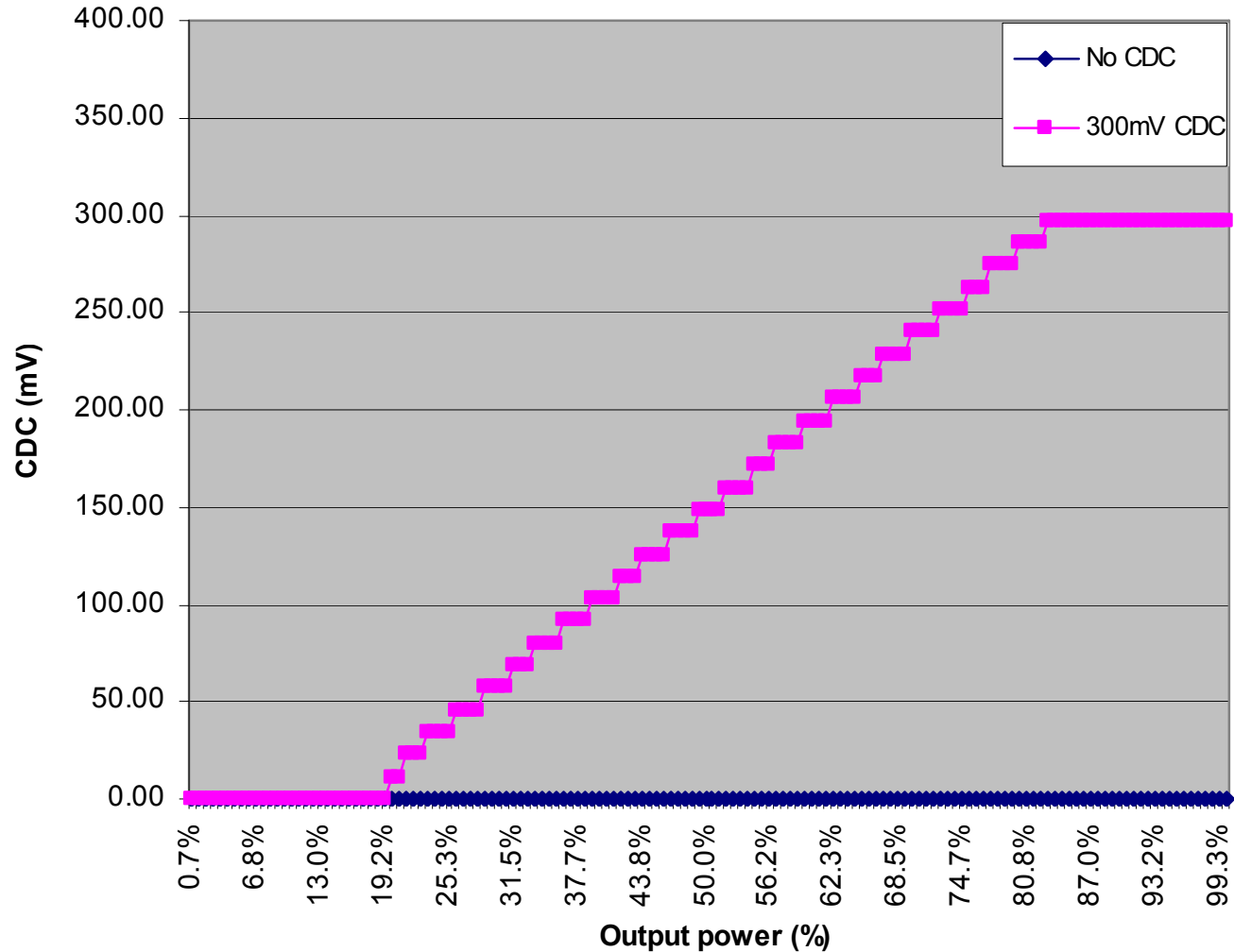

**Design Example:
iW1691 5V/2A design**

Design Target

Description	Symbol	Min	Typ	Max	Units	Comment
Input						
Voltage	V_{IN}	90		264	V _{AC}	
Frequency	f_{LINE}	47	50/60	63	Hz	
No-load Input Power (264V _{AC})				0.15	W	
Output						
Output Voltage	V_{OUT_CV}	4.85		5.25	V	Measured at the end of Cable
Output Current	I_{OUT_CV}		2		A	
Output Ripple Voltage	V_{RIPPLE}			100	mV _{P-P}	Measured at the End of DC Output cable $I_{OUT}=2A @T_A = 25^\circ C$ 20 MHz Bandwidth
Total Output Power						
Continuous Output Power	P_{OUT}			10	W	
Over Current Protection	I_{OUT_MAX}			2.5	A	Auto-restart
Efficiency	η		80		%	Measured at end of PCB, $V_{IN} = 115V_{AC}$ and 230Vac $I_{OUT} = 2A. (T_A = 25^\circ C)$
Environmental						
Conducted EMI		Meets CISPR22B / EN55022B				
Safety		Designed to meet IEC950, UL1950 Class II				
Ambient Temperature	T_{AMB}	0		40	°C	Free convection, sea level

A Typical Schematic

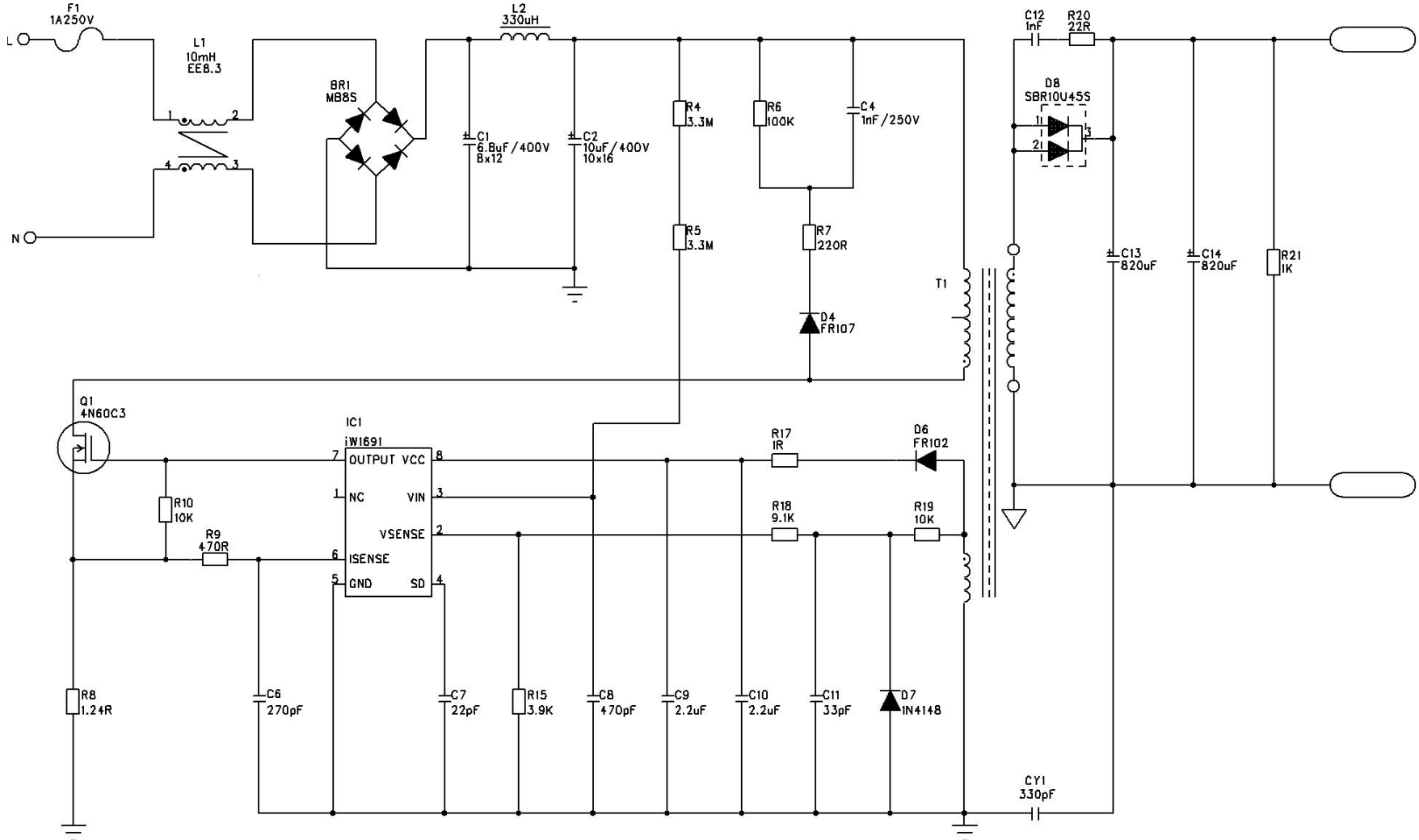

Cross Regulation, Ripple and Efficiency

Note: Output voltage is measured at end of PCB

V _{IN} (V _{AC})	P _{IN} (W)	V _{OUT} (V)	I _{OUT} (A)	V _{RIPPLE} (mV _{P-P})	P _{OUT} (W)	η (%)	OCP (A)	Average η (%)
90	0.05	5.03	0	10			2.29	82.2
	3.08	5.02	0.500	18	2.51	81.49		
	6.06	5.03	1.000	20	5.03	83.00		
	9.16	5.04	1.500	36	7.56	82.53		
	12.36	5.05	2.000	60	10.10	81.72		
115	0.06	5.02	0	10			2.28	82.8
	3.09	5.02	0.500	16	2.51	81.23		
	6.04	5.03	1.000	20	5.03	83.28		
	9.05	5.04	1.500	26	7.56	83.54		
	12.13	5.05	2.000	30	10.10	83.26		
230	0.08	5.00	0	10			2.28	81.0
	3.20	5.02	0.500	20	2.51	78.44		
	6.28	5.03	1.000	20	5.03	80.10		
	9.18	5.04	1.500	22	7.56	82.35		
	12.13	5.05	2.000	24	10.10	83.26		
264	0.01	5.00	0	10			2.29	79.7
	3.27	5.02	0.500	24	2.51	76.76		
	6.39	5.03	1.000	18	5.03	78.72		
	9.31	5.04	1.500	20	7.56	81.20		
	12.27	5.05	2.000	24	10.10	82.31		

Easy to Meet EPA_2.0

Table 1: Energy-Efficiency Criteria for Ac-Ac and Ac-Dc External Power Supplies in Active Mode: **Standard Models**

Nameplate Output Power (P _{no})	Minimum Average Efficiency in Active Mode (expressed as a decimal) ²
0 to ≤ 1 watt	≥ 0.480 * P _{no} + 0.140
> 1 to ≤ 49 watts	≥ [0.0626 * Ln (P _{no})] + 0.622
> 49 watts	≥ 0.870

Table 2: Energy-Efficiency Criteria for Ac-Ac and Ac-Dc External Power Supplies in Active Mode: **Low Voltage Models**

Nameplate Output Power (P _{no})	Minimum Average Efficiency in Active Mode (expressed as a decimal) ²
0 to ≤ 1 watt	≥ 0.497 * P _{no} + 0.067
> 1 to ≤ 49 watts	≥ [0.0750 * Ln (P _{no})] + 0.561
> 49 watts	≥ 0.860

EPA2.0 (Final) for Low Voltage Model (P_{no}=10W)

$$0.075 \times \ln(10W) + 0.561 = 73.4\%$$

Meet EPA2.0 with lots of Margin!

V _{IN} (VAC)	I _{OUT} (mA)	P _{IN} (W)	Measure at end of PCB				Measure at end of Cable 26AWG/1.2m, R _{Cable} =0.35Ω			
			V _{OUT_PCB} (V)	P _{OUT_PCB} (W)	EFF _{_PCB} (%)	AV-EFF _{_PCB} (%)	V _{OUT_Cable} (V)	P _{OUT_Cable} (W)	EFF _{_Cable} (%)	AV-EFF _{_Cable} (%)
115	500	3.090	5.02	2.51	81.23	82.83	4.85	2.42	78.40	76.77
	1000	6.040	5.03	5.03	83.28		4.68	4.68	77.48	
	1500	9.050	5.04	7.56	83.54		4.64	6.95	76.82	
	2000	12.130	5.05	10.10	83.26		4.51	9.02	74.36	
230	500	3.200	5.02	2.51	78.44	81.04	4.89	2.44	76.33	75.56
	1000	6.280	5.03	5.03	80.10		4.76	4.76	75.80	
	1500	9.180	5.04	7.56	82.35		4.64	6.95	75.74	
	2000	12.130	5.05	10.10	83.26		4.51	9.02	74.36	

Tight Output Current Regulation

*** Note: Output voltage is monitored at end of PCB**

$V_{IN}=90V_{ac}/50Hz$

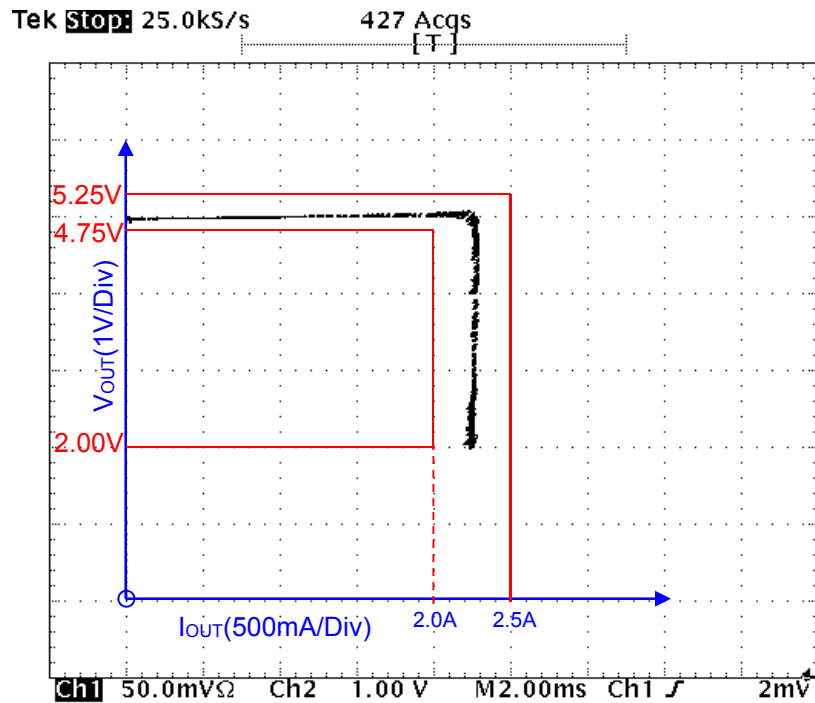

$V_{IN}=264V_{ac}/50Hz$

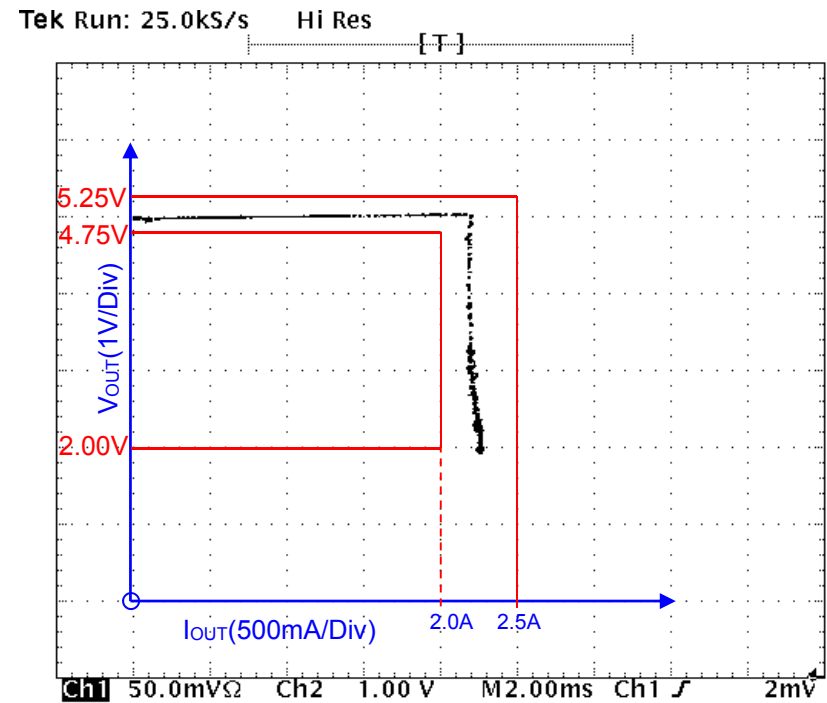

Fast Output Voltage Rise Time

90VAC, No Load

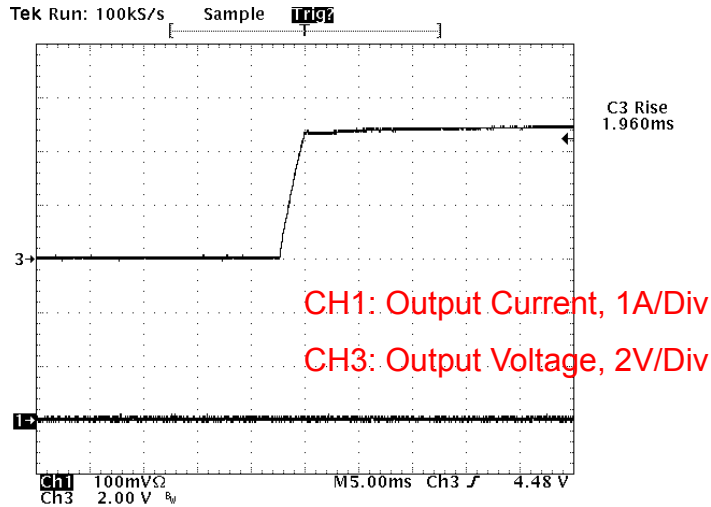

90VAC, Full Load

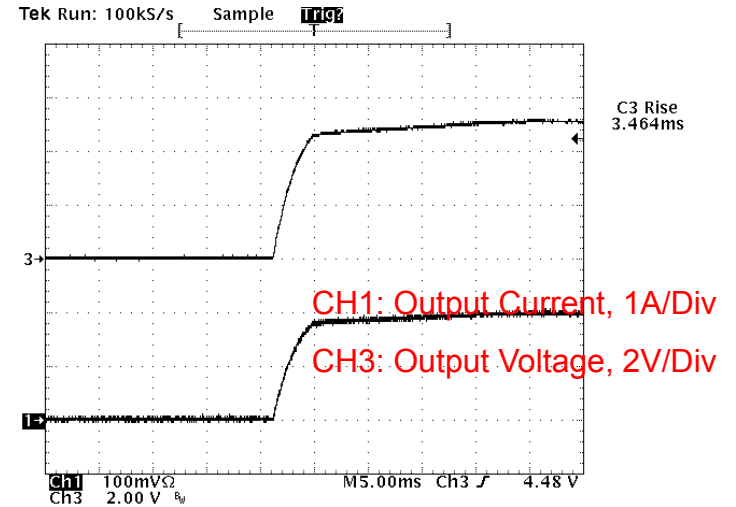

264VAC, No Load

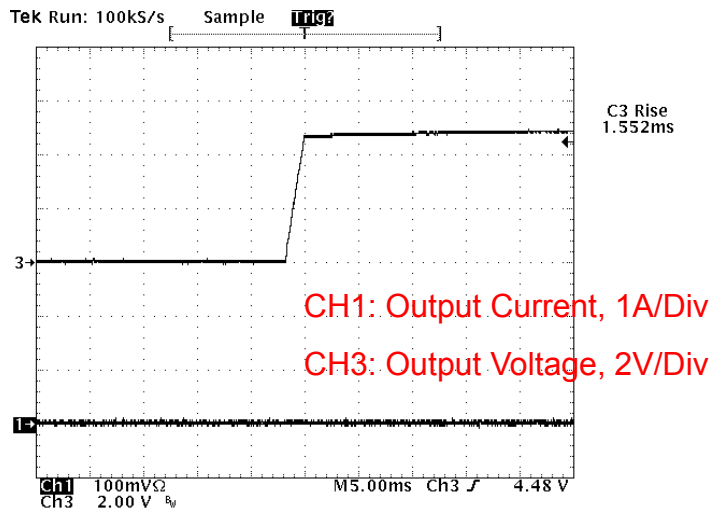

264VAC, Full Load

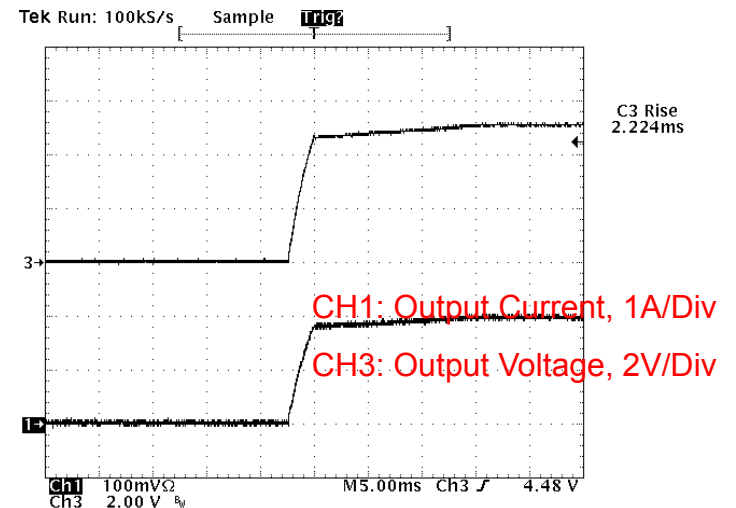

Startup after output short

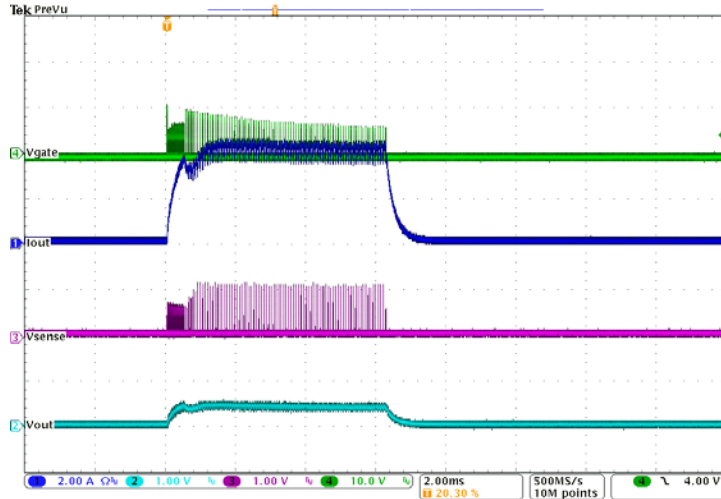

Short after regulation

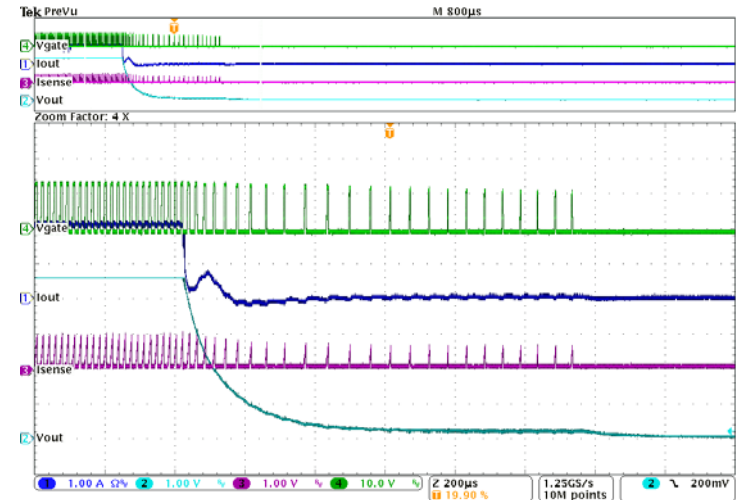

Vaux open

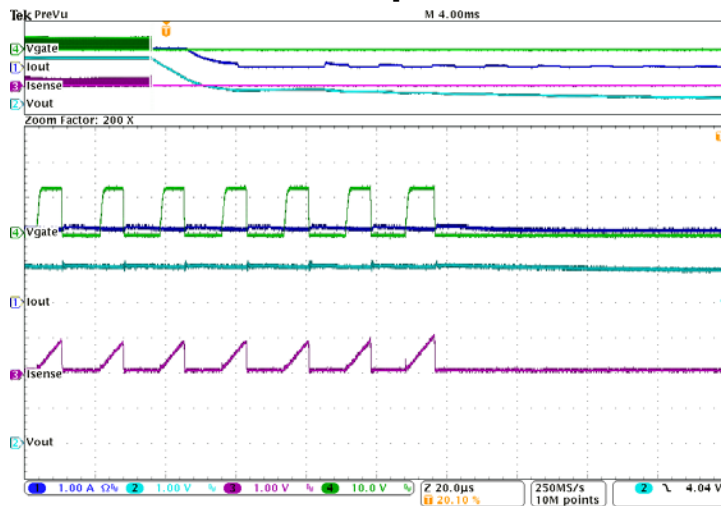

Vaux short

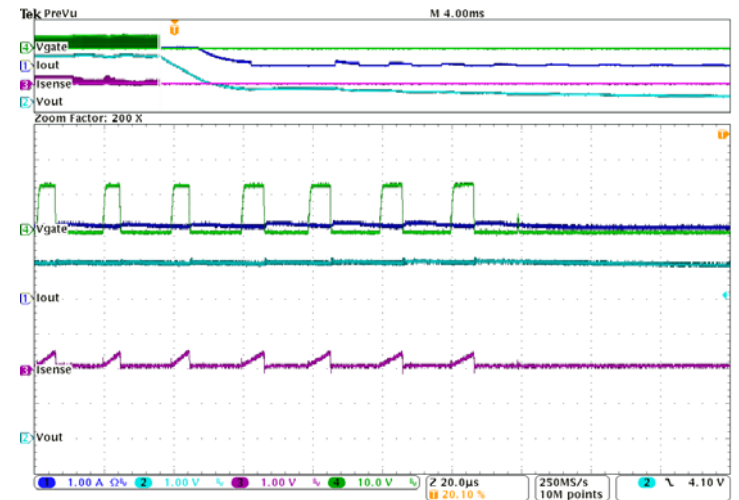

Current Sensing Resistor Short Protection

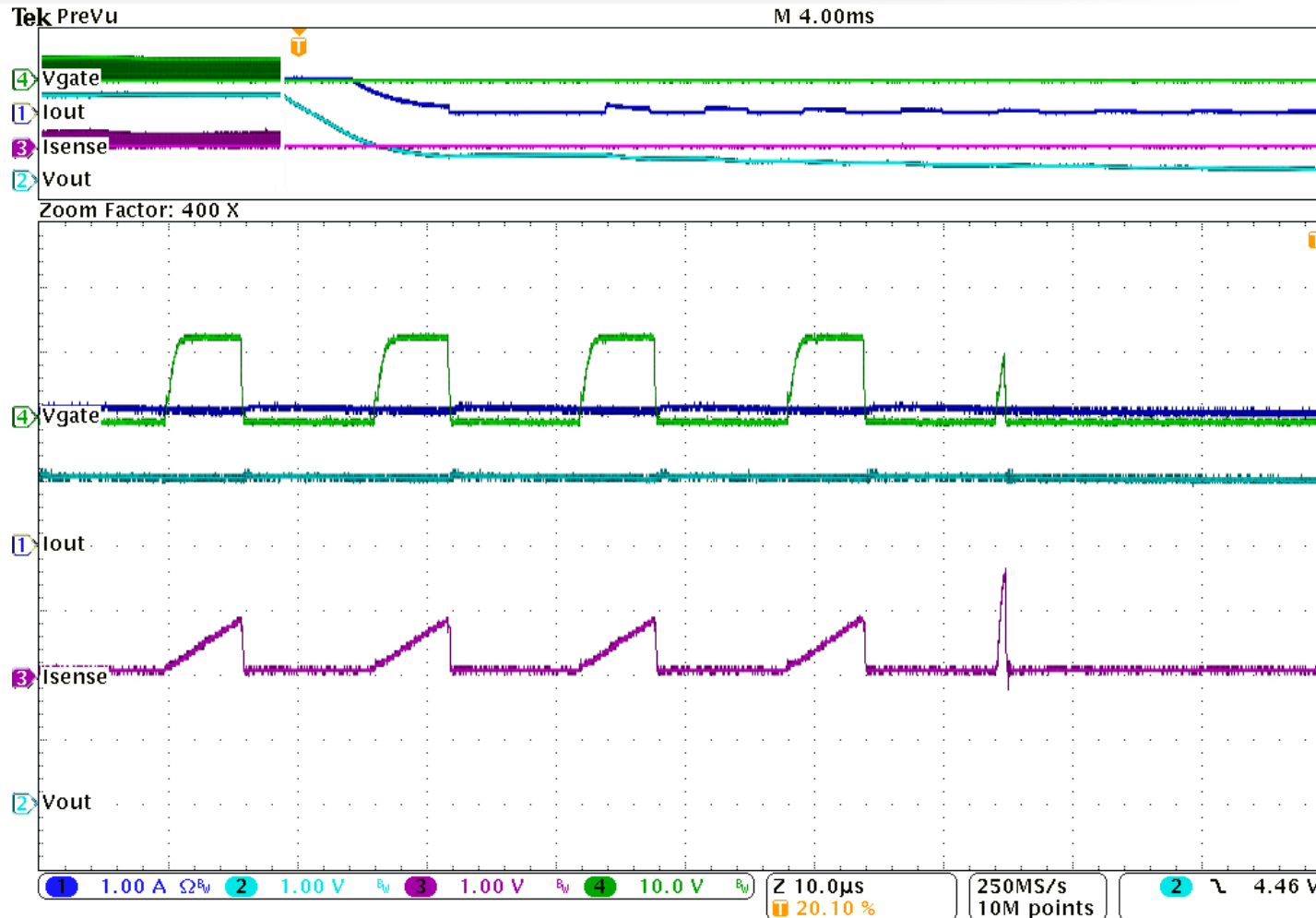

Ch1: Iout, Ch2: Vout
Ch3: Isense, Ch4: Vgate

Conducted EMI Result

Vin=115Vac/50Hz, Live

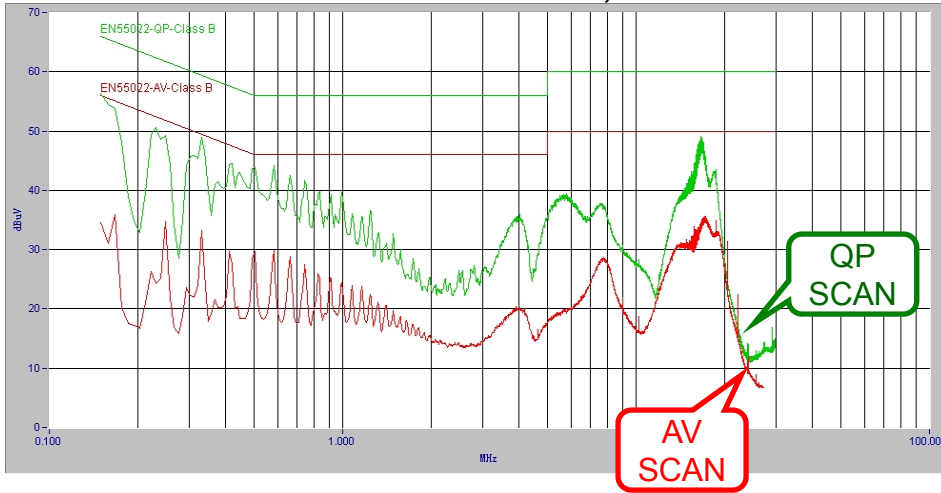

Vin=115Vac/50Hz, Neutral

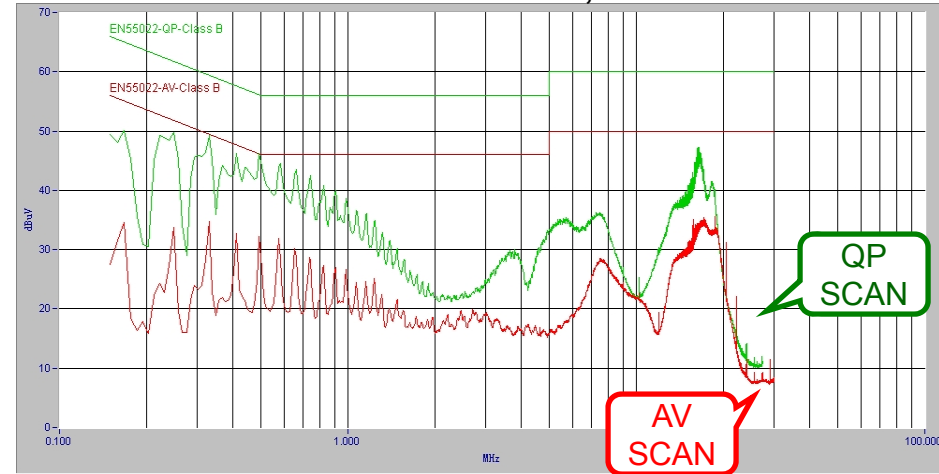

Vin=230Vac/50HZ, Live

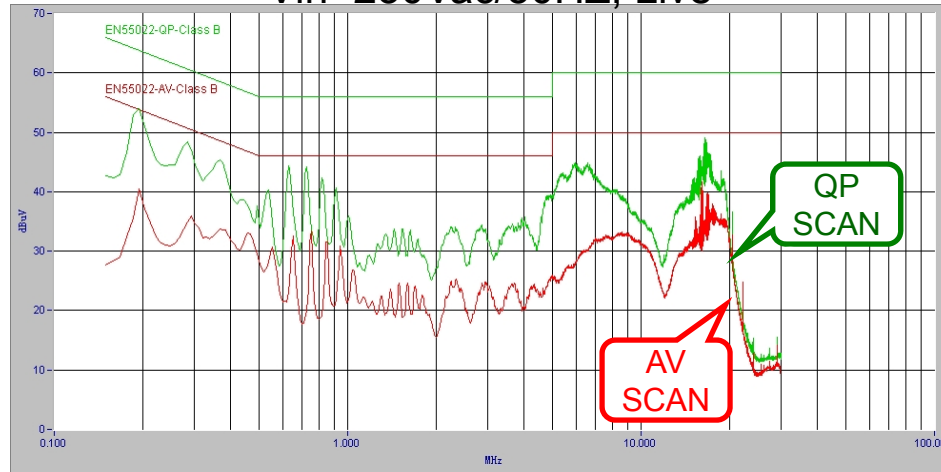

Vin=230Vac/50Hz, Neutral

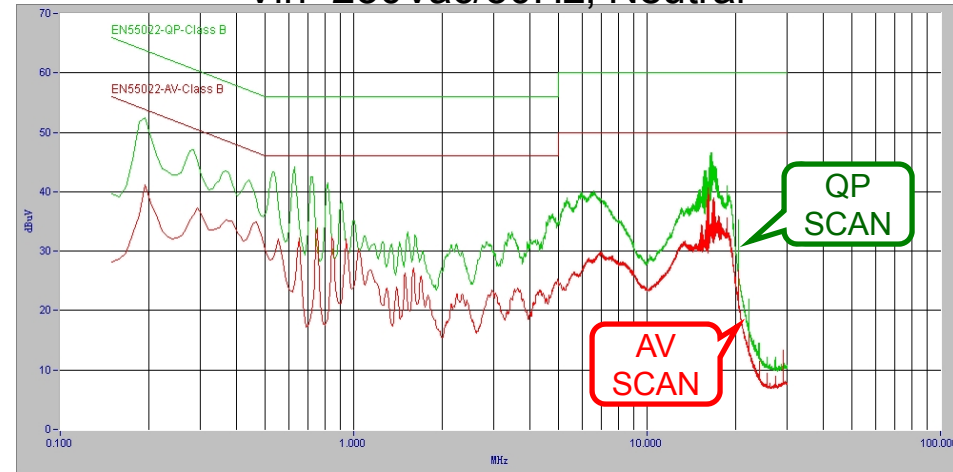

Note: Resistive & Full load. output (-) is connected to Earth.

Radiation RFI Result

230Vac/50Hz, Vertical

230Vac/50Hz, Horizontal

Anbotek Anbotek Compliance Laboratory Limited
 Product Safety 2/F, Langfeng Building, Kefa Road North, Hi-tech Industrial Park, Nanshan District, Shenzhen 518057, China

Site: 968 Chamber
 Tel: (86)755-26014771
 Fax: (86)755-26014772

Anbotek Anbotek Compliance Laboratory Limited
 Product Safety 2/F, Langfeng Building, Kefa Road North, Hi-tech Industrial Park, Nanshan District, Shenzhen 518057, China

Site: 968 Chamber
 Tel: (86)755-26014771
 Fax: (86)755-26014772

Job No.: File :IWATT Polarization: Vertical
 Standard: (RE)EN55022_class B_3m Power Source: AC 230V/50Hz
 Test item: Radiation Test Date: 2010/08/23
 Temp.(C)/Hum.(%) 25.5 / 42 % Time: 12:18:13
 EUT: Engineer Signature:
 Mode: Distance: 3m
 Model: 5V/2A-1

Job No.: File :IWATT Polarization: Horizontal
 Standard: (RE)EN55022_class B_3m Power Source: AC 230V/50Hz
 Test item: Radiation Test Date: 2010/08/23
 Temp.(C)/Hum.(%) 25.5 / 42 % Time: 12:20:17
 EUT: Engineer Signature:
 Mode: Distance: 3m
 Model: 5V/2A-1

Note:

Note:

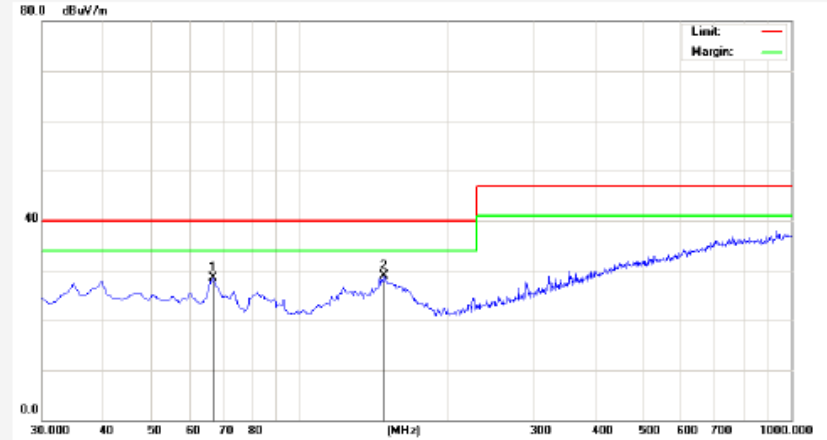
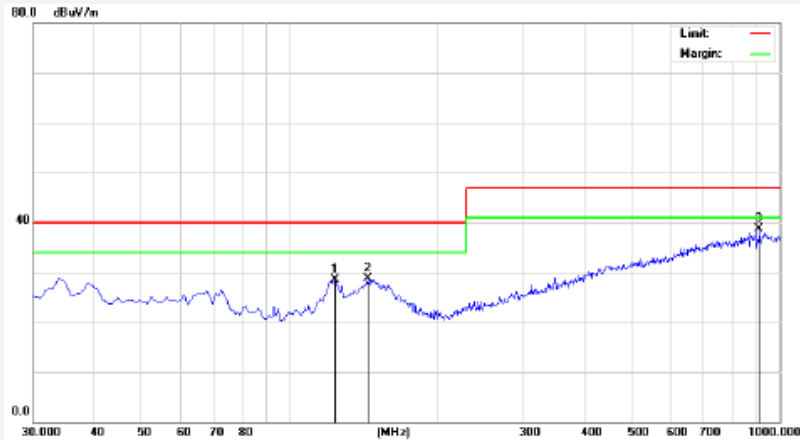

No.	Freq. (MHz)	Reading (dBuV/m)	Factor (dB/m)	Result (dBuV/m)	Limit (dBuV)	Over Limit (dB)	Detector	Remark
1	124.0900	14.22	14.28	28.50	40.00	-11.50	peak	
2	144.4800	12.87	16.79	28.86	40.00	-11.34	peak	
3	909.7900	11.94	26.72	38.66	47.00	-8.34	peak	

No.	Freq. (MHz)	Reading (dBuV/m)	Factor (dB/m)	Result (dBuV/m)	Limit (dBuV)	Over Limit (dB)	Detector	Remark
1	66.8800	15.72	12.75	28.47	40.00	-11.53	peak	
2	149.3100	12.87	16.14	28.81	40.00	-11.19	peak	

Note
 1, VCC diode : SRGC10DH

Note
 1, VCC diode : SRGC10DH

- **iW1691 provides the most cost-effective solution to achieve the small size high efficiency low-cost adapter design**
- **The efficiency can be over 80+ cross line and load**
- **Easy EMI design**
- **Achieve tight output voltage regulation**
- **Incorporated the proprietary Digital Primary-Feedback technology**
 - No Opto, No TL431, No secondary control circuits
- **Adaptive cycle-by-cycle Constant Current Regulations**
- **Multi-layer advanced protection features**
 - Isense short circuit protection and other single-point fault protections
 - Brown-out / recovery
 - OVP, UVP, short circuit,
- **More Reliable**
 - Low cost, Less components

Thanks