

REVISIONS			
REV	DESCRIPTION	DATE	APPROVED
00	INITIAL RELEASE	02/14/08	REV. T.
01	ADD 128 PACKAGE TABLE	4/24/08	REV. T.
02	REMOVED 128L TABLE; NEW PSC FOR 128L OPTION	3/4/11	JG
03	COMBINE POD & LAND PATTERN	6/24/13	KS

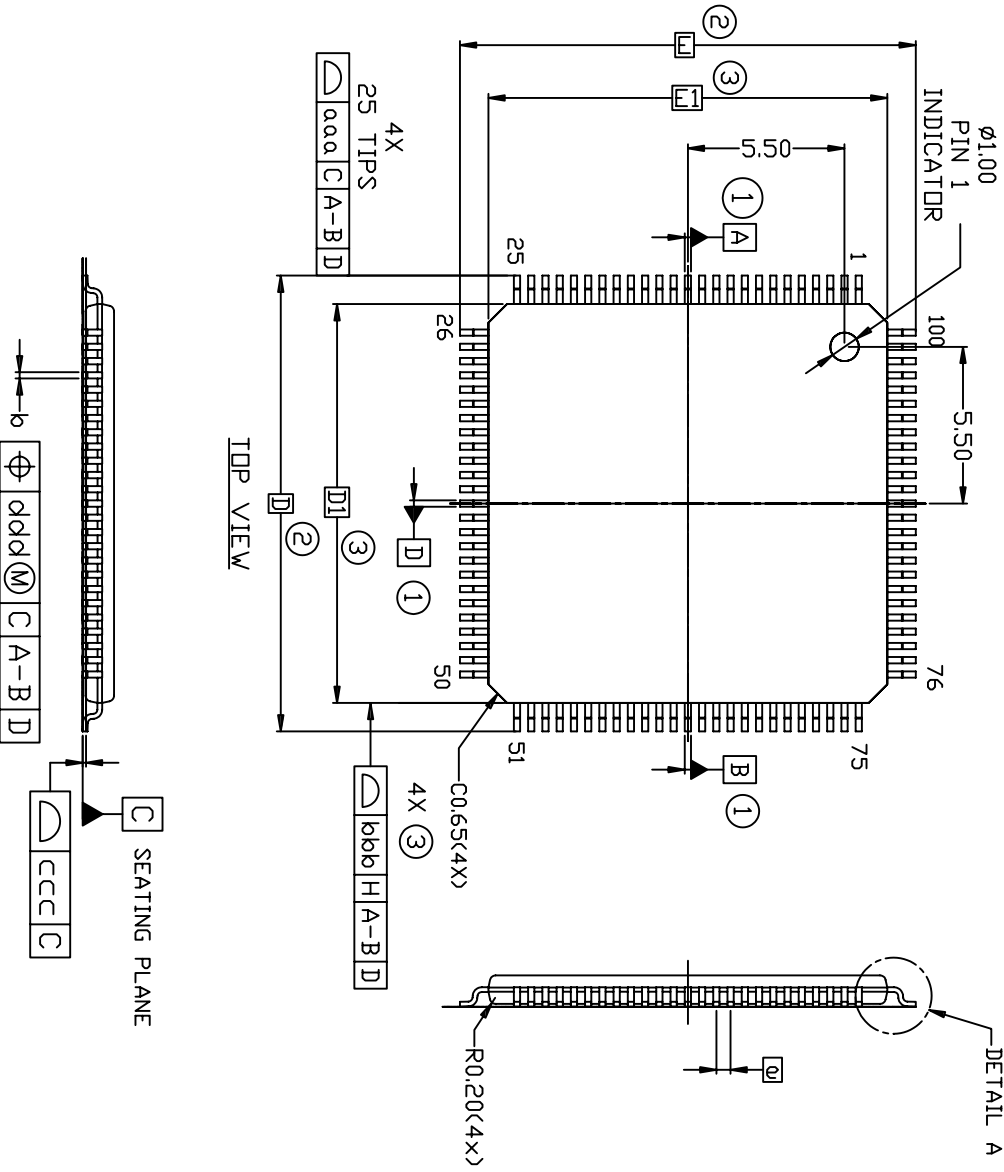

TOLERANCES UNLESS SPECIFIED		
DECIMAL	ANGULAR	
XX	±1°	
XX±		
XXX±		
APPROVALS	DATE	TITLE
DRAWN $\alpha d g$	02/14/08	EM/EMG PACKAGE OUTLINE
CHECKED		14.0 x 14.0 x 1.0 mm BODY
		TQFP
	SIZE C	DRAWING No. PSC-4193
		DO NOT SCALE DRAWING
		SHEET 1 OF 3



6024 Silver Creek Valley Road  
 San Jose CA 95138  
 PHONE: (408) 284-8200  
 FAX: (408) 284-8591  
 www.IDT.com

SYMBOL	Min.	Nom.	Max.
A	-	-	1.20
A1	0.05	-	0.15
A2	0.95	1.00	1.05
b	0.17	0.22	0.27
b1	0.17	0.20	0.23
D	-	16.00	BSC
D1	-	14.00	BSC
e	-	0.50	BSC
E	-	16.00	BSC
E1	-	14.00	BSC
θ	0°	3.5°	7°
θ1	0°	-	-
SYMBOL	Min.	Norm.	Max.
φ2	11°	12°	13°
φ3	11°	12°	13°
c	0.09	-	0.20
c1	0.09	-	0.16
L	0.45	0.60	0.75
L1	-	1.00	REF
R1	0.08	-	-
R2	0.08	-	0.20
REF	TOLERANCES OF FORM & POSITION		
aaa	0.20		
bbb	0.20		
ccc	0.08		
ddd	0.08		
N	100		

- NOTE :
- DATUM A-B AND D TO DETERMINE AT DATUM PLANE H.
  - TO BE DETERMINED AT SEATING DATUM PLAN C.
  - DIMENSION D1 AND E1 DO NOT INCLUDE MOLD PROTRUSIONS, ALLOWABLE PROTRUSION IS 0.25 mm PER SIDE. S1 AND E1 ARE MAXIMUM PLASTIC BODY SIZE DIMENSION INCLUDING MOLD MISMATCH.
  - DIMENSION b DOSE NOT INCLUDE DAMBAR PROTRUSION, ALLOWABLE DAMBAR PROTRUSION SHALL NOT CAUSE THE LEAD WIDTH TO EXCEED THE MAXIMUM b DIMENSION BY MORE THAN 0.08 mm. DAMBAR CANNOT BE LOCATED ON THE LOWER RADIUS OR THE FOOT. MINIMUM SPACE BETWEEN PROTRUSION AND ADJACENT LEAD IS 0.07 mm FOR 0.4mm AND 0.5 mm PITCH PACKAGE.
  - THESE DIMENSIONS APPLY TO THE FLAT SECTION OF THE BETWEEN 0.10 mm AND 0.25 mm FROM THE LEAD TIP.
  - A1 IS THE DEFINED AS THE DISTANCE FROM THE SEATING PLANE TO THE LOWEST POINT ON THE PACKAGE BODY.
  - PACKAGE DIMENSIONS CONFORM TO JEDEC MS-026 Rev.J

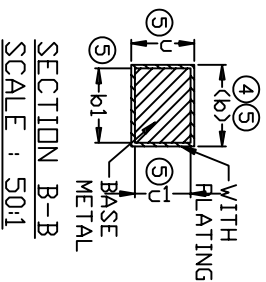
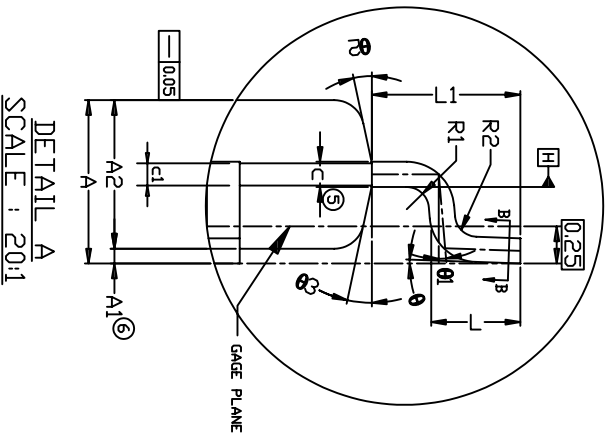

REVISIONS			
REV	DESCRIPTION	DATE	APPROVED
00	INITIAL RELEASE	02/14/08	REV T.
01	ADD 128 PACKAGE TABLE	4/24/08	REV T.
02	REMOVED 128L TABLE, NEW PSC FOR 128L OPTION	3/4/11	JG
03	COMBINE POD & LAND PATTERN	6/24/13	KS

TOLERANCES UNLESS SPECIFIED		DATE	
DECIMAL	ANGULAR	DATE	
±	±	02/14/08	
DRAWN <i>dalg</i>		TITLE EM/EMG PACKAGE OUTLINE	
CHECKED		14.0 x 14.0 x 1.0 mm BODY	
APPROVALS		TQFP	
XXXX		SIZE C	
DRAWING No.		PSC-4193	
DO NOT SCALE DRAWING		REV 03	
SHEET 2 OF 3			

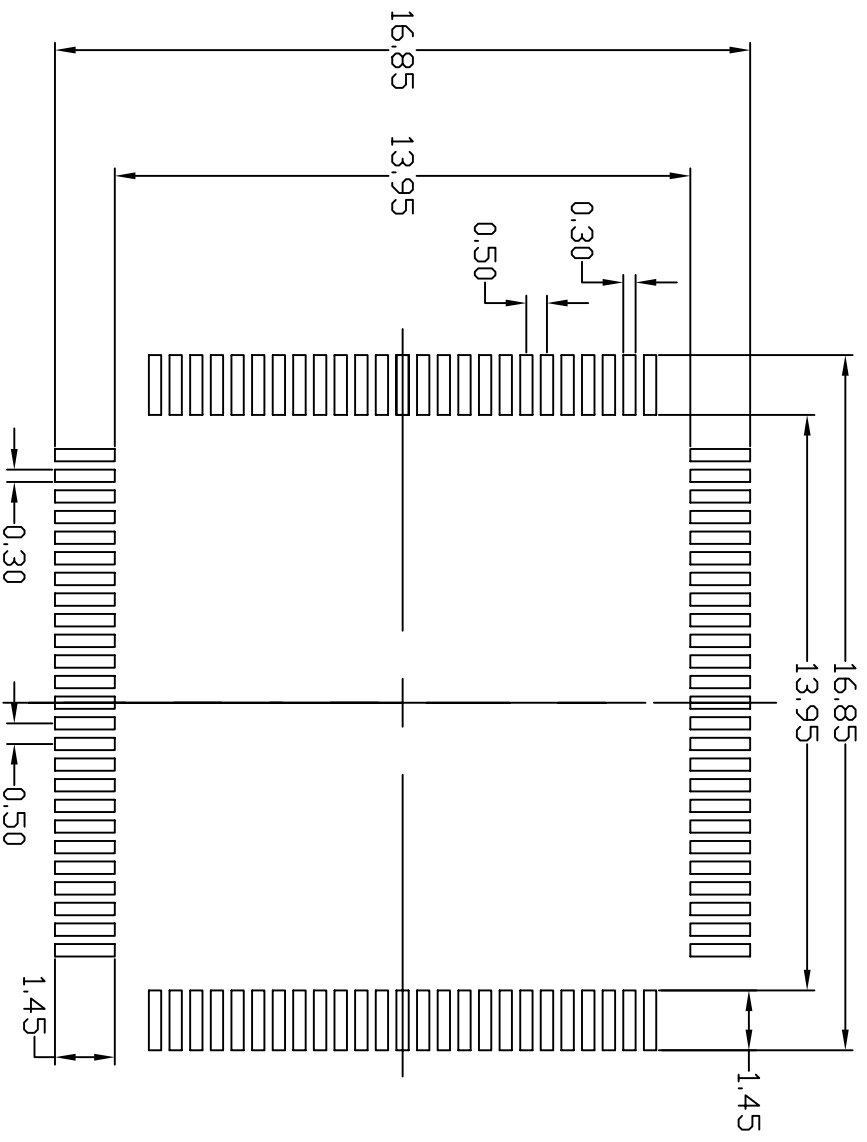

**IDT**<sup>TM</sup>  
 6024 Silver Creek Valley Road  
 San Jose CA 95138  
 PHONE: (408) 284-8200  
 FAX: (408) 284-8591  
[www.IDT.com](http://www.IDT.com)

REVISIONS			
REV	DESCRIPTION	DATE	APPROVED
00	INITIAL RELEASE	02/14/08	REV T.
01	ADD 128 PACKAGE TABLE	4/24/08	REV T.
02	REMOVED 128L TABLE; NEW PSC FOR 128L OPTION	3/4/11	JG
03	COMBINE POD & LAND PATTERN	6/24/13	KS



**RECOMMENDED FOOT PRINT DIMENSION**

- NOTES:**
1. ALL DIMENSION ARE IN mm. ANGLES IN DEGREES.
  2. TOP DOWN VIEW. AS VIEWED ON PCB.
  3. LAND PATTERN IN BLACK. NSMD PATTERN ASSUMED.
  4. LAND PATTERN RECOMMENDATION PER IPC-7351B LP CALCULATOR.

TOLERANCES UNLESS SPECIFIED DECIMAL      ANGULAR XX±            ±1° XXX±		 6024 Silver Creek Valley Road San Jose CA 95138 PHONE: (408) 284-8200 FAX: (408) 284-8591	
APPROVALS	DATE		
DRAWN <i>04dG</i>	02/14/08	14.0 x 14.0 x 1.0 mm BODY	
CHECKED		TOFP	
		SIZE	DRAWING No. PSC-4193
			REV 03
		DO NOT SCALE DRAWING	SHEET 3 OF 3