

DATE CREATED		REVISIONS		
REV	DESCRIPTION	AUTHOR		
00	Initial Release	RC		
01	COMBINE POD & LAND PATTERN	J.H		
02	ADD EPAD OPTION	J.H		
03	ADD EPAD OPTION	J.H		
04	ADD EPAD OPTION	CM		

NOTE: REFER TO DCP FOR OFFICIAL RELEASE DATE

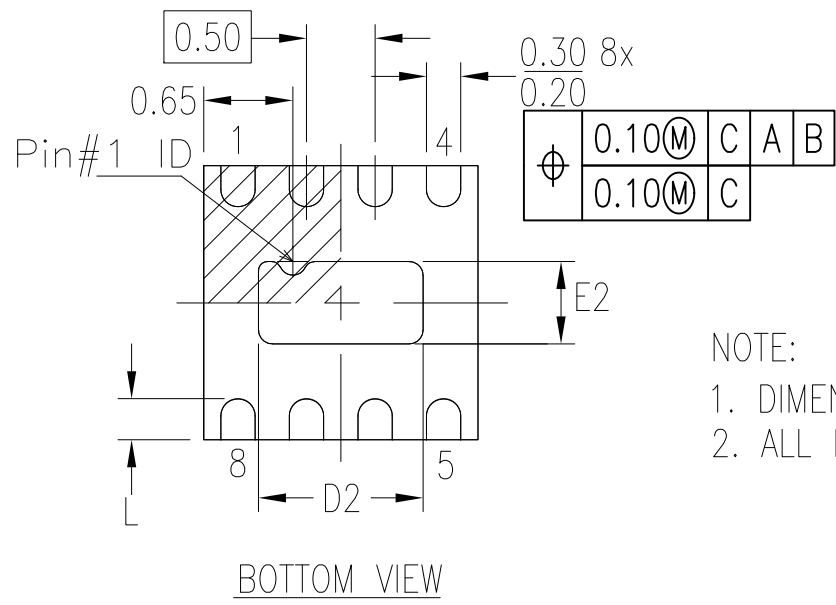
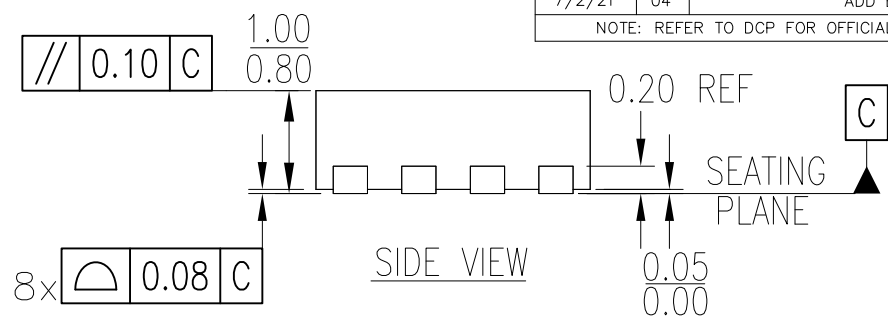
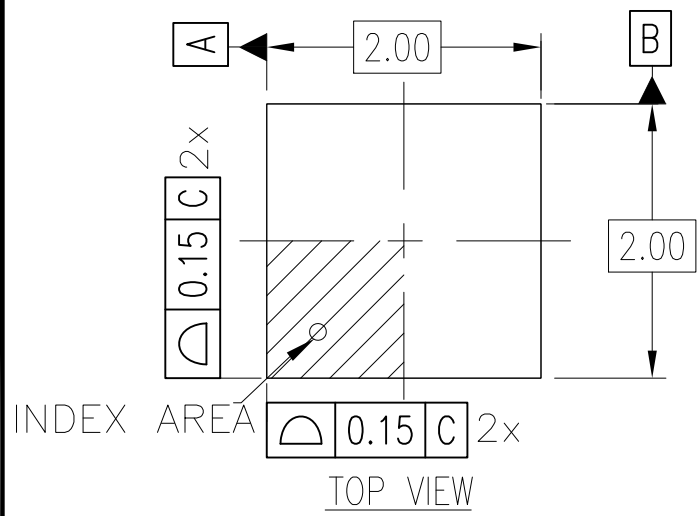

	EPAD OPTIONS														
	P1			P2			P3			P4			P5		
	MIN.	NOM.	MAX.	MIN.	NOM.	MAX.	MIN.	NOM.	MAX.	MIN.	NOM.	MAX.	MIN.	NOM.	MAX.
D2	1.05	1.15	1.25	0.80	0.90	1.00	0.75	0.80	0.85	0.85	0.90	0.95	1.15	1.20	1.25
E2	0.45	0.55	0.65	1.50	1.60	1.70	1.55	1.60	1.65	1.65	1.70	1.75	0.60	0.65	0.70
L	0.20	0.30	0.40	0.25	0.35	0.45	0.25	0.30	0.35	0.25	0.30	0.35	0.30	0.35	0.40

NOTE:
 1. DIMENSIONING AND TOLERANCING CONFORM TO ASME Y14.5-2009.
 2. ALL DIMENSIONS ARE IN MILLIMETERS.

TOLERANCES UNLESS SPECIFIED DECIMAL ANGULAR X± .1 ±1° XX± .05 XXX± .030	6024 Silver Creek Valley Road San Jose CA 95138 PHONE: (408) 284-8200 FAX: (408) 284-3572	
TITLE NB/NBG8 Package Outline Drawing 2.0 x 2.0 x 0.9 mm Body 0.5mm Pitch DFN		
SIZE C	DRAWING No. PSC-4178	REV 04
DO NOT SCALE DRAWING		SHEET 1 OF 2

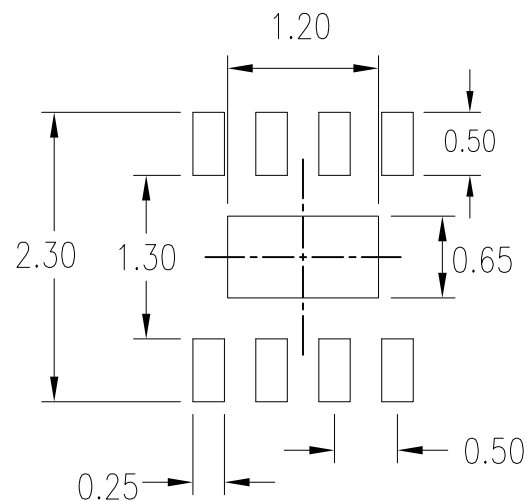
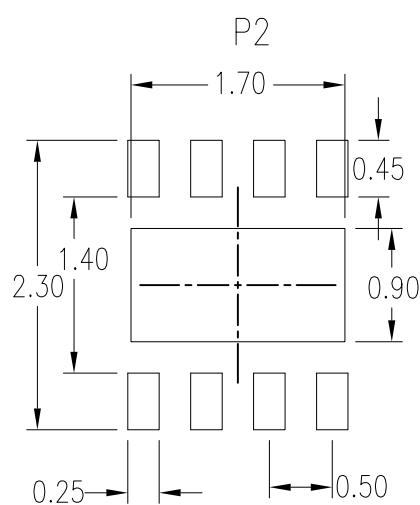
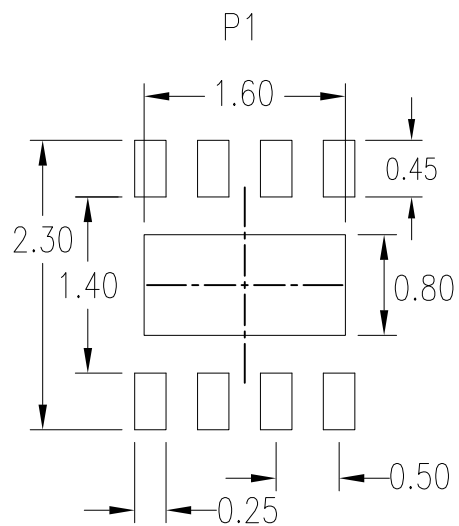
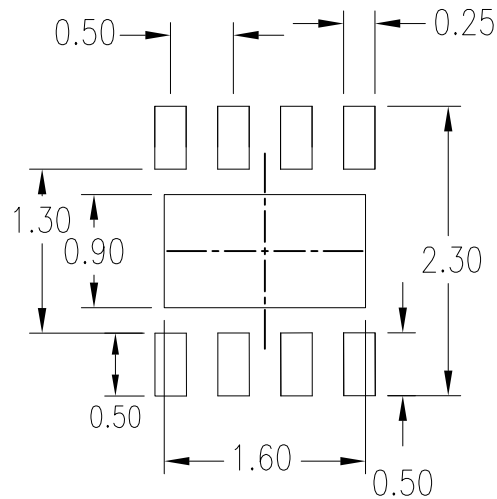
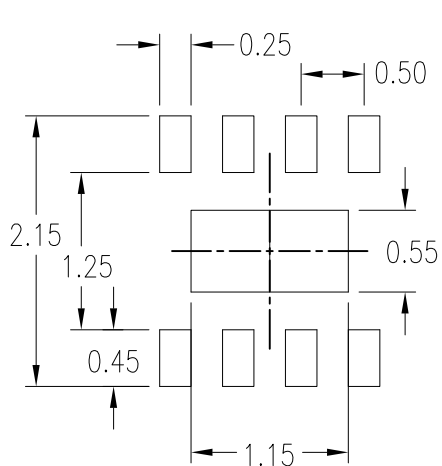

P1

P2

P3

P4

P5

DATE CREATED		REVISIONS		
DATE CREATED	REV	DESCRIPTION	AUTHOR	
02/02/12	00	Initial Release	RC	
02/07/14	01	COMBINE POD & LAND PATTERN	J.H	
6/13/16	02	ADD EPAD OPTION	J.H	
10/9/17	03	ADD EPAD OPTION	J.H	
7/2/21	04	ADD EPAD OPTION	CM	

NOTE: REFER TO DCP FOR OFFICIAL RELEASE DATE

NOTES:

1. ALL DIMENSIONS ARE IN mm. ANGLES IN DEGREES.
2. TOP DOWN VIEW. AS VIEWED ON PCB.
3. COMPONENT OUTLINE SHOWS FOR REFERENCE IN GREEN.
4. LAND PATTERN IN BLUE. NSMD PATTERN ASSUMED.
5. LAND PATTERN RECOMMENDATION PER IPC-7351B GENERIC REQUIREMENT FOR SURFACE MOUNT DESIGN AND LAND PATTERN.

TOLERANCES UNLESS SPECIFIED DECIMAL ANGULAR XX± .05 ±1° XXX± .030	6024 Silver Creek Valley Road San Jose CA 95138 PHONE: (408) 284-8200 FAX: (408) 284-3572	
	RENESAS	
TITLE NB/NBG8 Package Outline Drawing 2.0 x 2.0 x 0.9 mm Body 0.5mm Pitch DFN		
SIZE C	DRAWING No. PSC-4178	REV 04
DO NOT SCALE DRAWING		SHEET 2 OF 2