

REVISIONS			
REV	DESCRIPTION	DATE	APPROVED
00	INITIAL RELEASE	05/31/12	R.T
01	Change DIM A1	01/22/13	J.Huo
02	COMBINE POD & LAND PATTERN	09/06/13	KS
03	CHANGE E2/D2 & D98 DIMENSION REMOVE PAGE 2	7/11/14	J.Huo

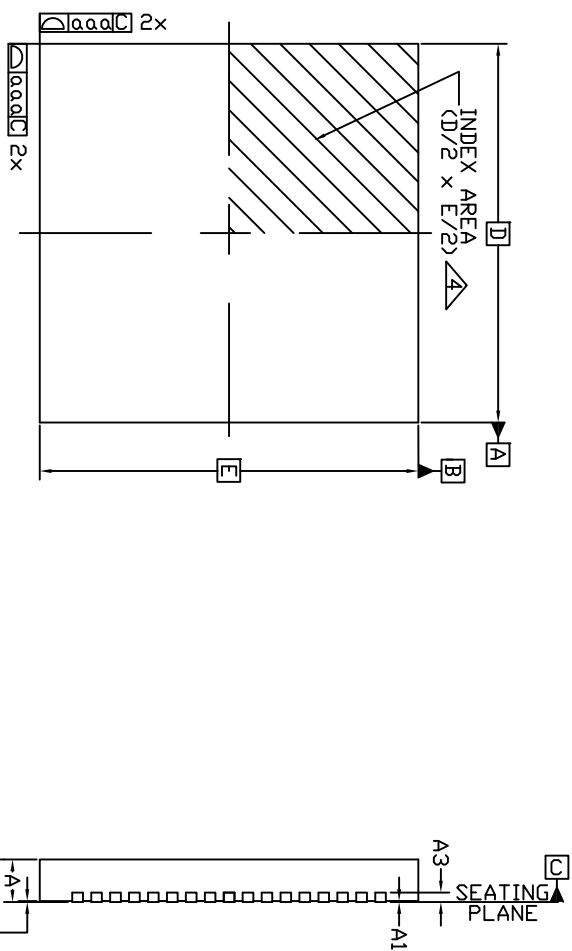

TOP VIEW

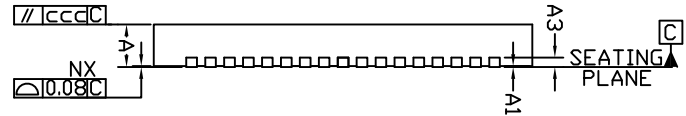

SIDE VIEW

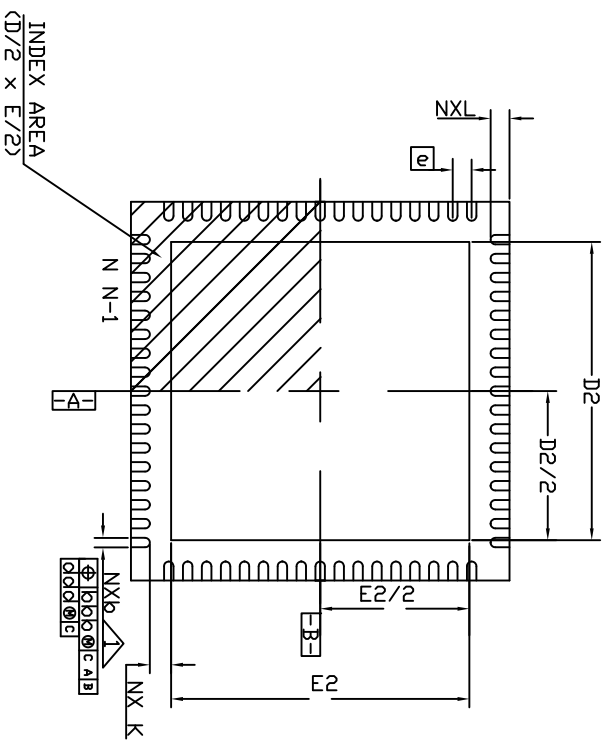

BOTTOM VIEW

SYMBOL	DIMENSION		
	MIN	NOM	MAX
A	0.80	0.90	1.00
A1	0.00	0.02	0.05
A3	----	0.20 ref	----
b	0.15	0.20	0.25
D BSC		8.00	
E BSC		8.00	
D1 BSC		----	
E1 BSC		----	
D2	6.10	6.20	6.30
E2	6.10	6.20	6.30
L	0.30	0.40	0.50
e		0.40	
N		68	
ND		17	
NE		17	
L1	0.03	----	0.15
K	0.20	----	----
TOLERANCE OF FORM & POSITION			
ooo		0.10	
bbb		0.10	
ccc		0.10	
ddd		0.05	
NOTES		1,2,10	

Notes:

- All dimensions are in millimeters while angle is in degrees (°).
- N is the total number of terminals.
- The terminal #1 identifier and terminal numbering convention shall conform to JEDEC publication 95, SPP-002. Details of terminal #1 identifier are optional, but must be located within the zone indicated. The terminal #1 may be either a mold or marked feature.
- Dimension b applies to metallized terminal and is measured between 0.15 and 0.30 mm from the terminal tip. If the terminal has the optional radius on the other end of the terminal, the dimension b should not be measured in that radius area.
- ND and NE refer to the number of terminals on each D and E side respectively.

TOLERANCES UNLESS SPECIFIED
 DECIMAL ANGULAR
 XXX+ ±
 XXXXX±

IDT
 6024 Silver Creek Valley Road
 San Jose, CA 95138
 PHONE: (408) 294-8200
 FAX: (408) 294-8591
 www.IDT.com

APPROVALS DATE TITLE
 DRAWN /B4/C 05/31/12 ND/NDG68 PACKAGE OUTLINE
 CHECKED 8.0 x 8.0 x 0.90 mm BODY
 0.4 mm Pitch
 SIZE DRAWING No. PSC-4195
 DO NOT SCALE DRAWING SHEET 1 OF 2

REVISIONS			
REV	DESCRIPTION	DATE	APPROVED
00	INITIAL RELEASE	05/31/12	R.T
01	Change DIM A1	01/22/13	JHug
02	COMBINE POD & LAND PATTERN	09/06/13	KS
03	CHANGE E2/D2 & DIMENSION REMOVE PAGE 2	7/11/14	JHug

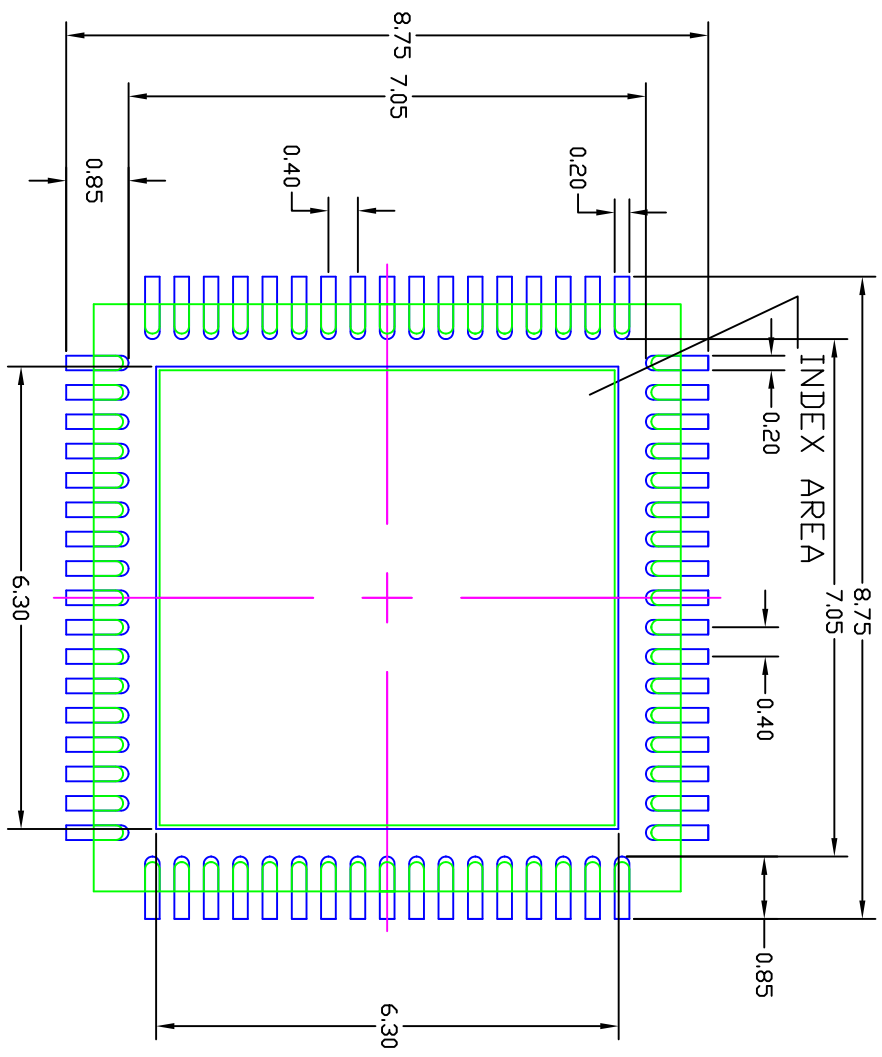

- NOTES:
1. ALL DIMENSION ARE IN mm. ANGLES IN DEGREES.
 2. TOP DOWN VIEW, AS VIEWED ON PCB.
 3. COMPONENT OUTLINE SHOW FOR REFERENCE IN GREEN.
 4. LAND PATTERN IN BLUE. NSMD PATTERN ASSUMED.
 5. LAND PATTERN RECOMMENDATION PER IPC-7351B GENERIC REQUIREMENT FOR SURFACE MOUNT DESIGN AND LAND PATTERN.

TOLERANCES UNLESS SPECIFIED		www.idt.com	
DECIMAL	ANGULAR	6024 Silver Creek Valley Road San Jose, CA 95138 PHONE: (408) 284-8200 FAX: (408) 284-8591	
±	±	IDT	
XXXX±	XXXX±	ND/NDG68 PACKAGE OUTLINE	
APPROVALS	DATE	8.0 x 8.0 x 0.90 mm BODY	
DRAWN	05/31/12	0.4 mm Pitch	
CHECKED		SIZE DRAWING No. PSC-4195	
		REV 03	
DO NOT SCALE DRAWING		SHEET 2 OF 2	