

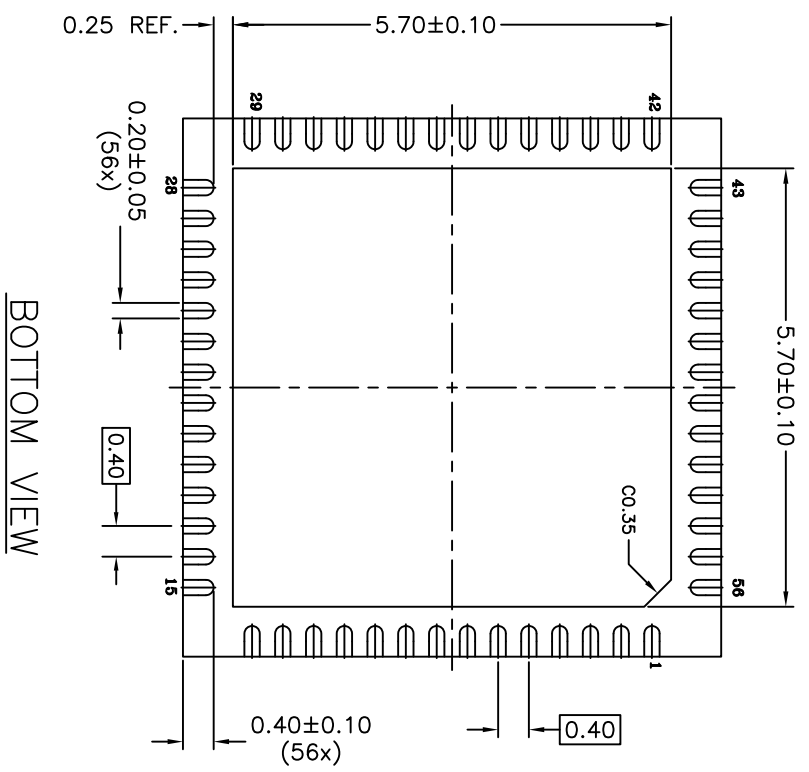

REVISIONS			
REV	DESCRIPTION	DATE	APPROVED
00	INITIAL RELEASE	10/03/11	M. ROY
01	COMBINE POD & LAND PATTERN	9/6/13	KS
02	ADD NOTE RECOMMENDED LAND PATTERN	2/21/14	J.H

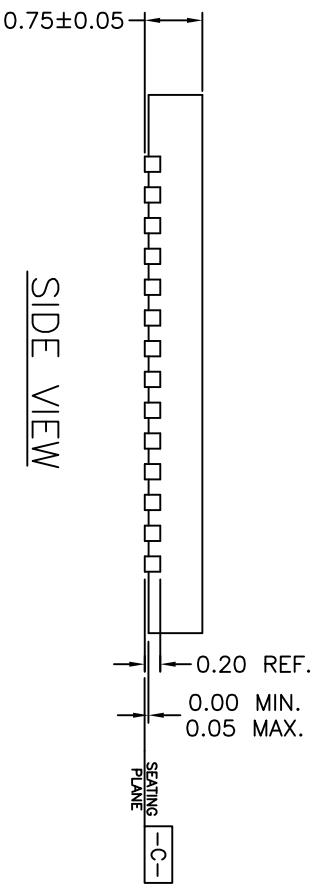
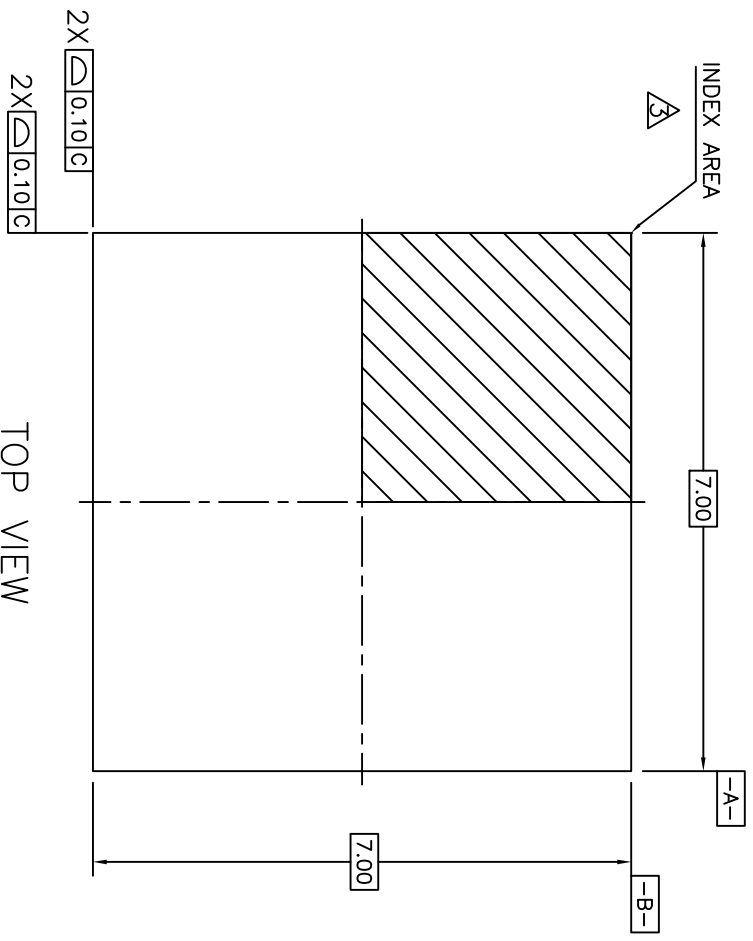

- NOTES:**
1. ALL DIMENSIONING AND TOLERANCING CONFORM TO ANSI Y14.5M-1982
 2. ALL DIMENSIONS ARE IN MILLIMETERS.
 3. INDEX AREA (PIN1 IDENTIFIER)

TOLERANCES UNLESS SPECIFIED		DATE		TITLE	
DECIMAL	ANGULAR	10/03/11		NT/NTG56 PACKAGE OUTLINE	
XX±				7.0 x 7.0 mm BODY - 0.75mm thick	
XXX±				0.40 mm Pitch QFN (SAWN Type)	
APPROVALS				SIZE	DRAWING No.
DRAWN <i>mlr</i>				C	PSC-4392
CHECKED					

IDT
 6024 Silver Creek Valley Road
 San Jose, CA 95138
 PHONE: (408) 284-8200
 FAX: (408) 284-8591
 www.IDT.com

DO NOT SCALE DRAWING

SHEET 1 OF 2

REVISIONS			
REV	DESCRIPTION	DATE	APPROVED
00	INITIAL RELEASE.	10/03/11	M. ROY
01	COMBINE POD & LAND PATTERN	9/6/13	KS
02	ADD NOTE RECOMMENDED LAND PATTERN	2/21/14	JH

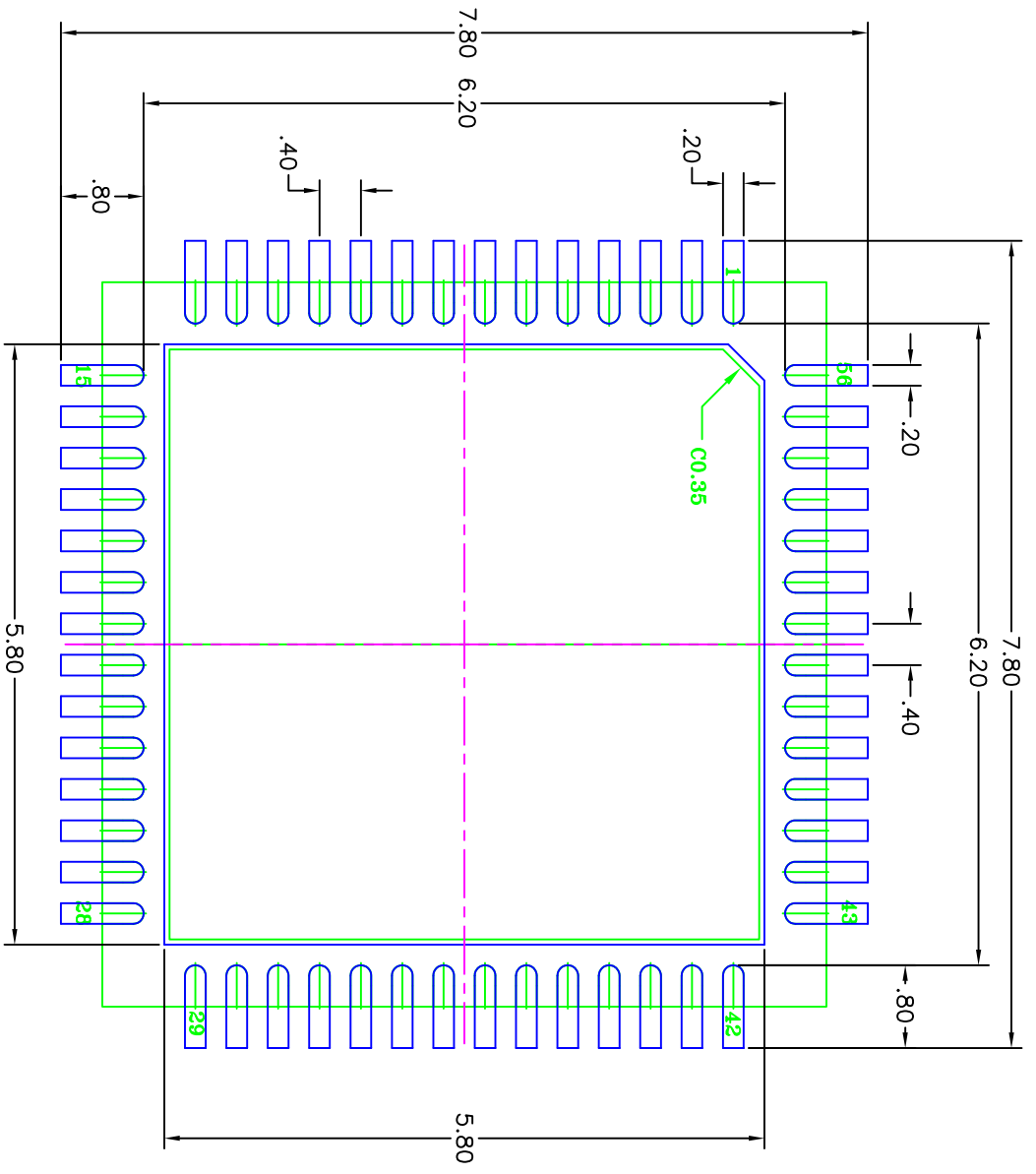

RECOMMEND LAND PATTERN DIMENSION

NOTES:

1. ALL DIMENSION ARE IN mm. ANGLES IN DEGREES.
2. TOP DOWN VIEW. AS VIEWED ON PCB.
3. COMPONENT OUTLINE SHOW FOR REFERENCE IN GREEN.
4. LAND PATTERN IN BLUE. NSMD PATTERN ASSUMED.
5. LAND PATTERN RECOMMENDATION PER IPC-7351B GENERIC REQUIREMENT FOR SURFACE MOUNT DESIGN AND LAND PATTERN.

TOLERANCES UNLESS SPECIFIED		ANGULAR	
DECIMAL	ANGULAR		
XX±			
XXX±			
XXXX±			
APPROVALS	DATE	TITLE	
DRAWN <i>mde</i>	10/03/11	NT/NTG56 PACKAGE OUTLINE	
CHECKED		7.0 x 7.0 mm BODY - 0.75mm thick	
		0.40 mm Pitch QFN (SAWN Type)	
		SIZE	REV
		C	02
DRAWING No. PSC-4392		DO NOT SCALE DRAWING	
SHEET 2 OF 2			

IDT
 www.IDT.com
 6024 Silver Creek Valley Road
 San Jose, CA 95138
 PHONE: (408) 284-8200
 FAX: (408) 284-8591