

REVISIONS			
REV	DESCRIPTION	DATE	APPROVED
00	INITIAL RELEASE	4/27/15	JHUA

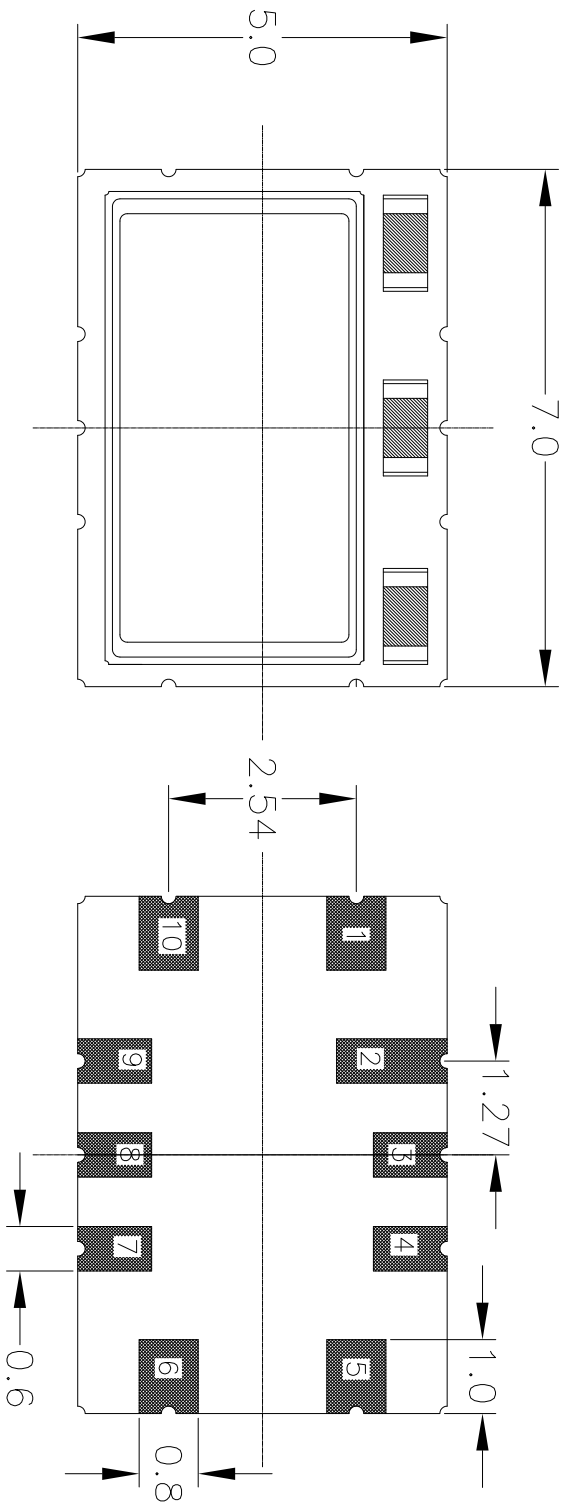

TOP VIEW

BOTTOM VIEW

SIDE VIEW

NOTES:  
1. ALL DIMENSIONS IN MM.

TOLERANCES UNLESS SPECIFIED		 <b>IDT</b> <sup>TM</sup>	6024 Silver Creek Valley Rd San Jose, CA 95138 PHONE: (408) 727-6116 FAX: (408) 492-8674
DECIMAL	ANGULAR		
XXE	±		
XXXXE			
APPROVALS	DATE	TITLE	SIZE
DRAWN / P&G	4/27/15	SC10 PACKAGE OUTLINE	C
CHECKED		7.0 x 5.0 mm BODY	DRAWING No.
		2.0 mm Thick	PSC-4607
			REV
			00
DO NOT SCALE DRAWING			SHEET 1 OF 2

REVISIONS			
REV	DESCRIPTION	DATE	APPROVED
00	INITIAL RELEASE	4/2/15	J.H.I.A

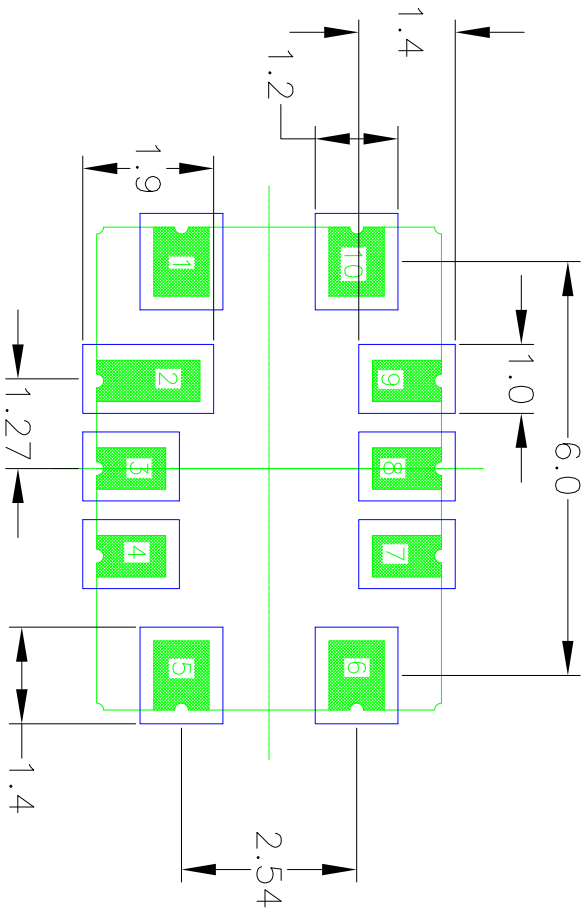

### RECOMMENDED LAND PATTERN

- NOTES:
1. ALL DIMENSION ARE IN mm. ANGLES IN DEGREES.
  2. TOP DOWN VIEW AS VIEWED ON PCB.
  3. COMPONENT OUTLINE SHOWN FOR REFERENCE IN GREEN.
  4. LAND PATTERN IN BLUE. NSMD PATTERN ASSUMED.
  5. LAND PATTERN RECOMMENDATION PER IPC-7351B GENERIC REQUIREMENT FOR SURFACE MOUNT DESIGN AND LAND PATTERN.

TOLERANCES UNLESS SPECIFIED			
DECIMAL	±	ANGULAR	
XXX±			
XXXX±			
APPROVALS	DATE	TITLE	SC10 PACKAGE OUTLINE
DRAWN <i>DAG</i>	4/2/15	GRAM	7.0 x 5.0 mm BODY
CHECKED			2.0 mm Thick
		SIZE	C
		DRAWING No	PSC-4607
		REV	00
		DO NOT SCALE DRAWING	
		SHEET 2 OF 2	

**IDT™** 6024 Silver Creek Valley Rd  
 San Jose, CA 95138  
 PHONE: (408) 727-6116  
 FAX: (408) 492-8574  
[www.IDT.com](http://www.IDT.com)