

Plastic Packages for Integrated Circuits

Package Outline Drawing

Y10.3x3

10 Lead Dual Flat Embedded Laminate Package

Rev 1, 9/20

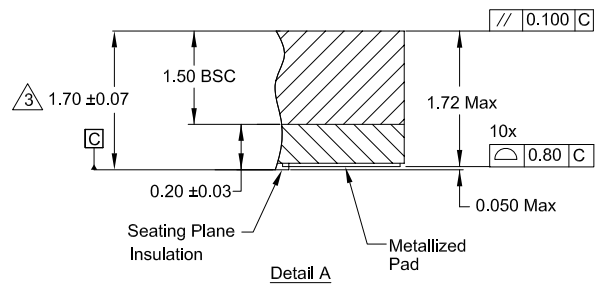
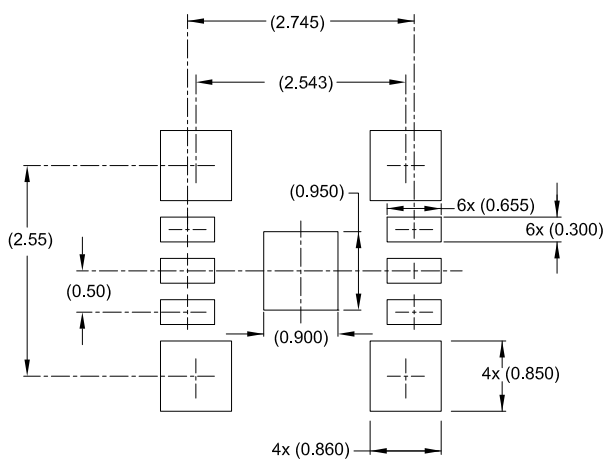
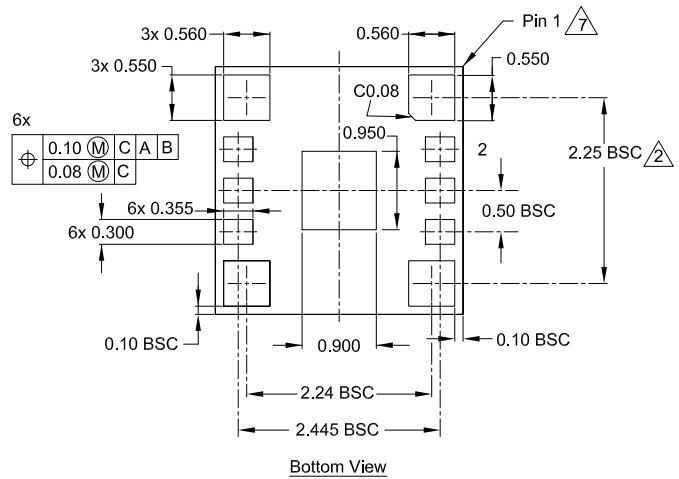
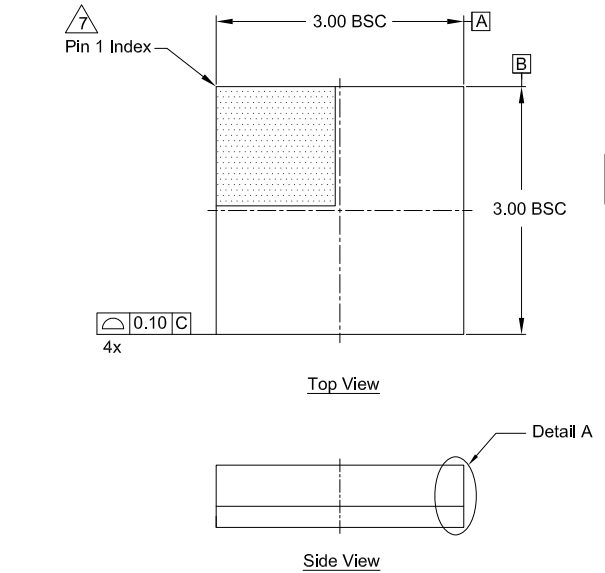

Notes :

- All dimensions are in mm. Dimensions in () for reference only.
- Represents the basic terminal pitch. Specifies the true geometric position of the terminal axis.
- Dimension includes package warpage.
- Exposed metallized pads are Cu pads with surface finish protection.
- Package dimensions refer to JEDEC MO-208 rev.c.
- Dimensioning and tolerancing conform to ASME Y14.5m-1994. Unless otherwise specified, tolerance: Decimal ±0.05
- The configuration of the pin #1 identifier is optional, but must be located within the zone indicated. The pin #1 identifier can be either a mold or mark feature.