

Renesas RA Family

FPB-RA2E2 Fast Prototyping Board

1. Introduction

The FPB-RA2E2 Fast Prototyping Board provides an entry point for evaluation, prototyping and development with the RA2E2 MCU. Moreover, since this board incorporates an emulator circuit, you can use it for designing your own applications without needing to make further investments in tools. This product includes through-holes for pin headers that allow access to all MCU signal pins, allowing easy prototyping with a breadboard.

2. Package Contents

- FPB-RA2E2 Fast Prototyping Board (RTK7FPA2E2S00001BE)
- Quick Start Guide (this document)

3. Board Specifications

Item	Specification
Evaluation MCU	Part No: R7FA2E2A74CNK; package: 24-pin HWQFN
	On-chip memory: 64 KB ROM, 8 KB RAM, 2 KB data flash memory
Board size	Size: 53 mm x 85 mm; thickness: 11.5 mm
Power-supply voltage	VCC: 3.3 V to 5.5 V. MCU operation voltage range 1.6 V to 5.5 V
Power-supply circuit	USB connector: VBUS (5 V input); VBUS is converted to 3.3 V by LDO
	2-pin external power-supply header*1
Push switch	Reset switch x 1; user switch x 1
LED	Power indicator: green x 1, user: green x 2, On-board Debugger ACT LED: green x 1
USB connector	Connector: Micro USB Type-B
Pmod™ connector	Connector: Angle type, 12-pin x 2
Arduino™ connector	Connector: 6-pin x 1, 8-pin x 2, 10-pin x 1
	The interface is compatible with Arduino™ UNO R3
MCU header*1	Header: 32 pins x 2
Emulator	E2 Emulator On-Board programmer / debugger

*1 This part is not mounted

4. Board Layout

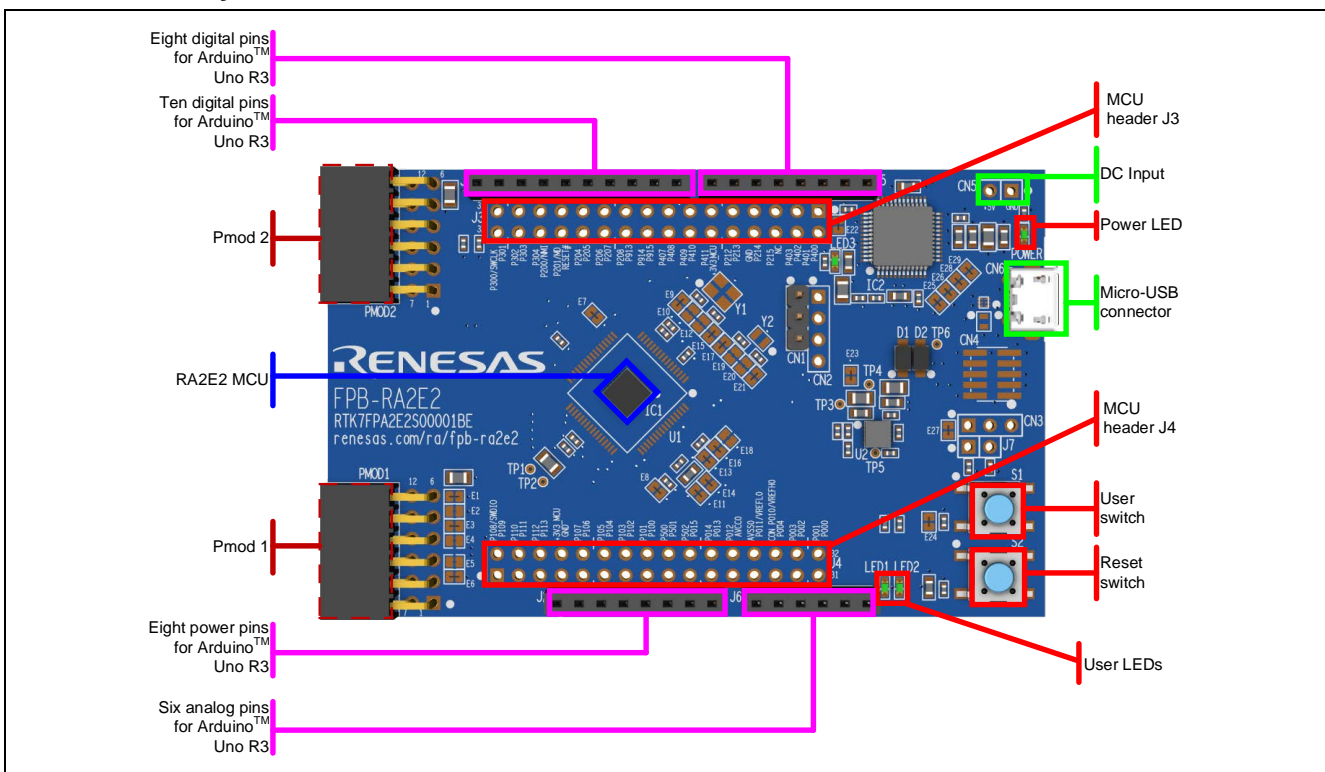

Figure 1. FPB-RA2E2 Board Layout

5. Arduino Interface

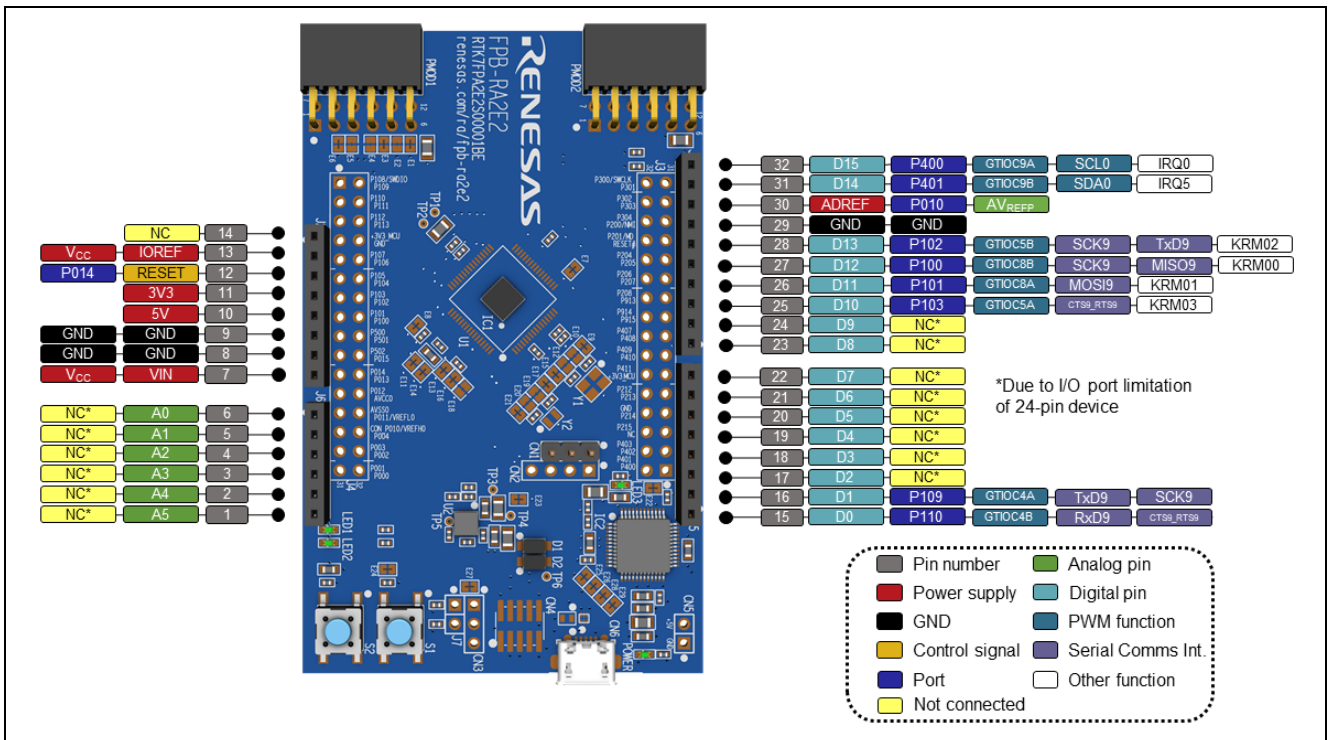

Figure 2. FPB-RA2E2 Arduino Interface

6. Pmod Interface

The FPB-RA2E2 Fast Prototyping Board has two Pmod connectors. Pmod 1 supports the Type 2A and Type 3A interfaces and can also be configured for Type 6A. Pmod 2 supports Type 3A only.

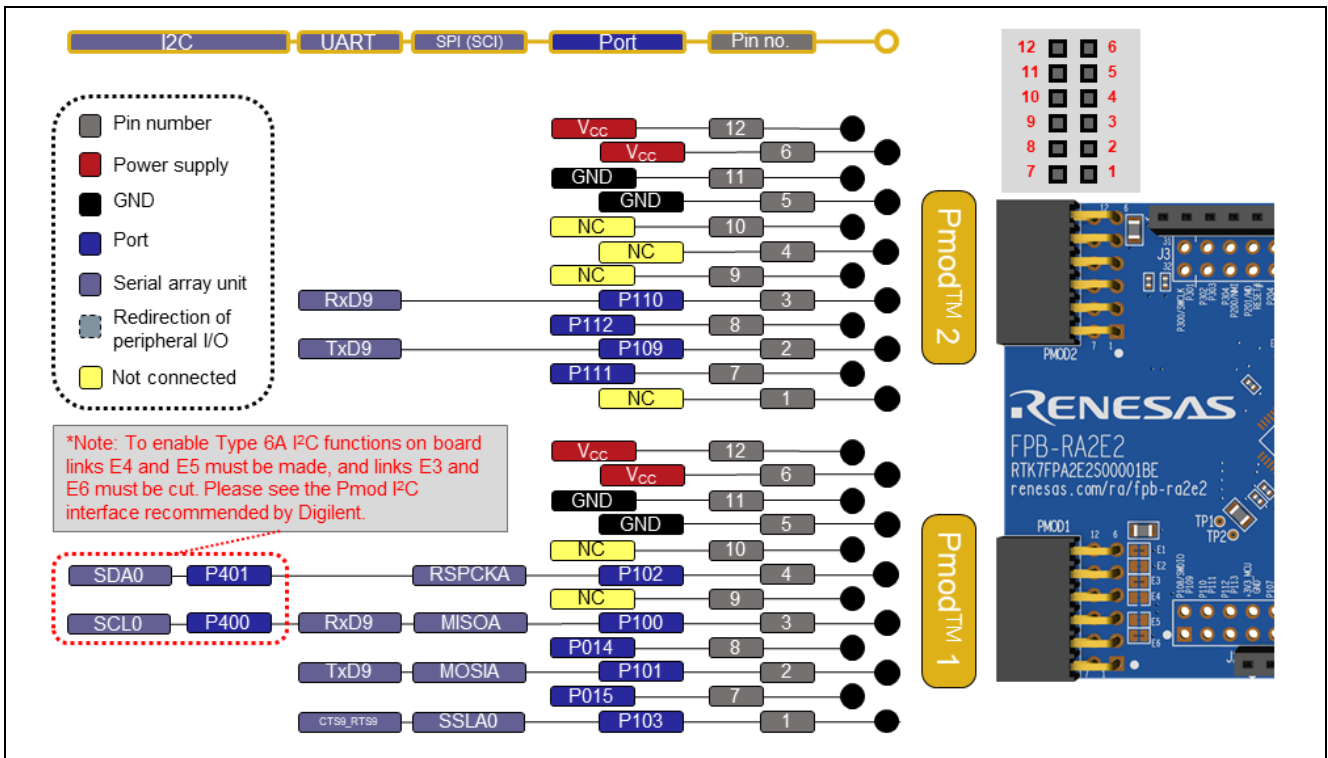

Figure 3. FPB-RA2E2 Pmod Interface

7. Note on Using the Board

Before using this board, download the user's manual from the web site at renesas.com/ra/fpb-ra2e2, and check the full specifications.

