

File		
8V9705x Evaluation Board Schematics		
Size	Document Number	Rev
C	<Doc>	A
Date:	Thursday, May 14, 2015	Sheet 1 of 1

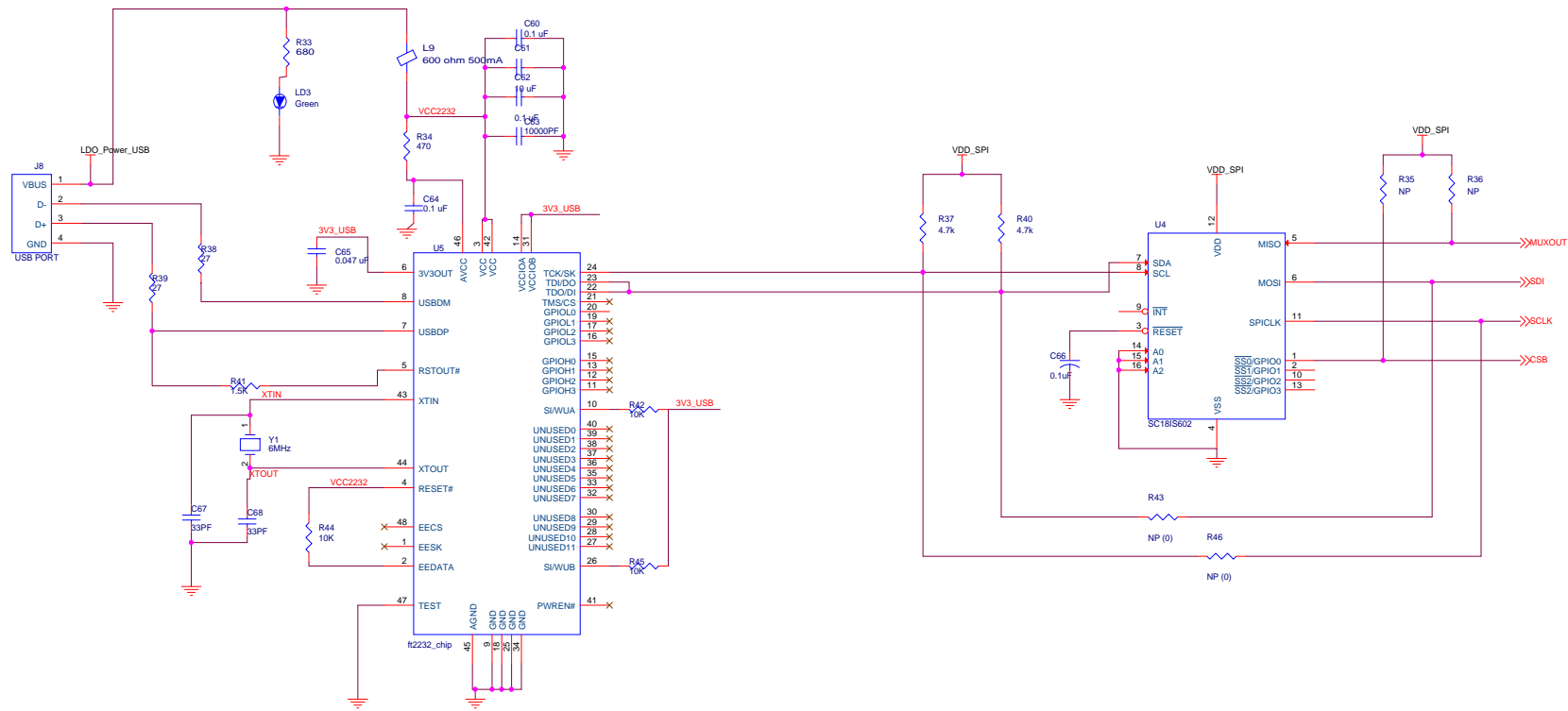

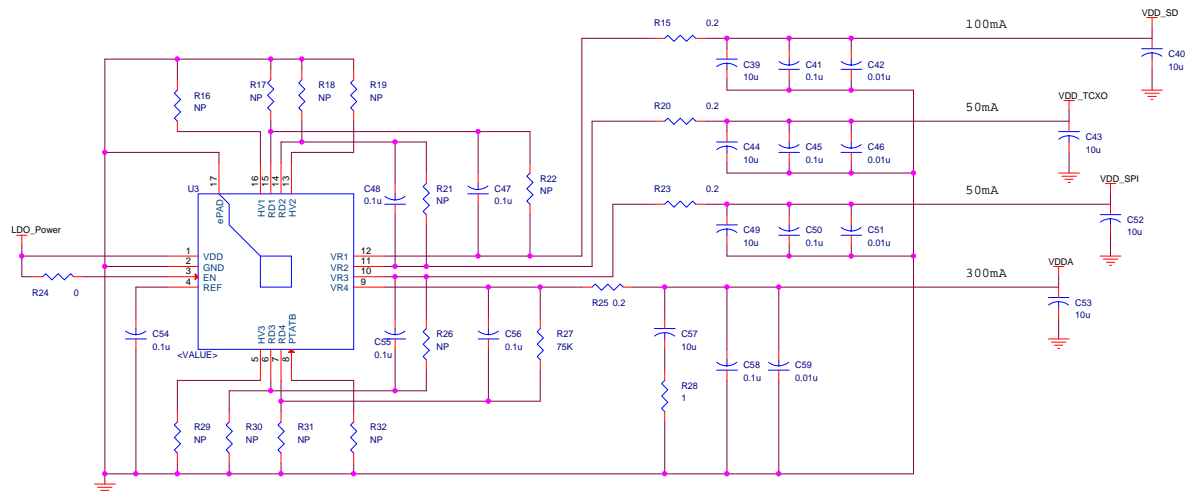
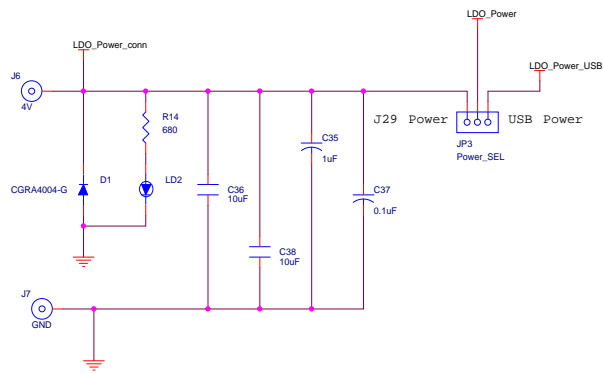

VDDA = V_CP, VDDA, V_VCO, VDDD

VDD_SPI = Translator, I2C PU, SPI PU

File			
8V9705x Evaluation Board Schematics			
Size	Document Number	Rev	
C	<Doc>	A	
Date:	Wednesday, May 13, 2015	Sheet	1 of 1