

PROJECT NAME	Indira3		Fidus Systems 375 Terry Fox Drive, Ottawa, ON K2K 0J8	
DESIGN	TITLE IDT8A34043			
DB	SUBTITLE Block Diagram			
DRAWN	DRAWING NUMBER SK-10280-01		REVISION 1.2	
CHECK	RELEASE DATE 27 October 2016		SHEET 1 OF 9	
DB				

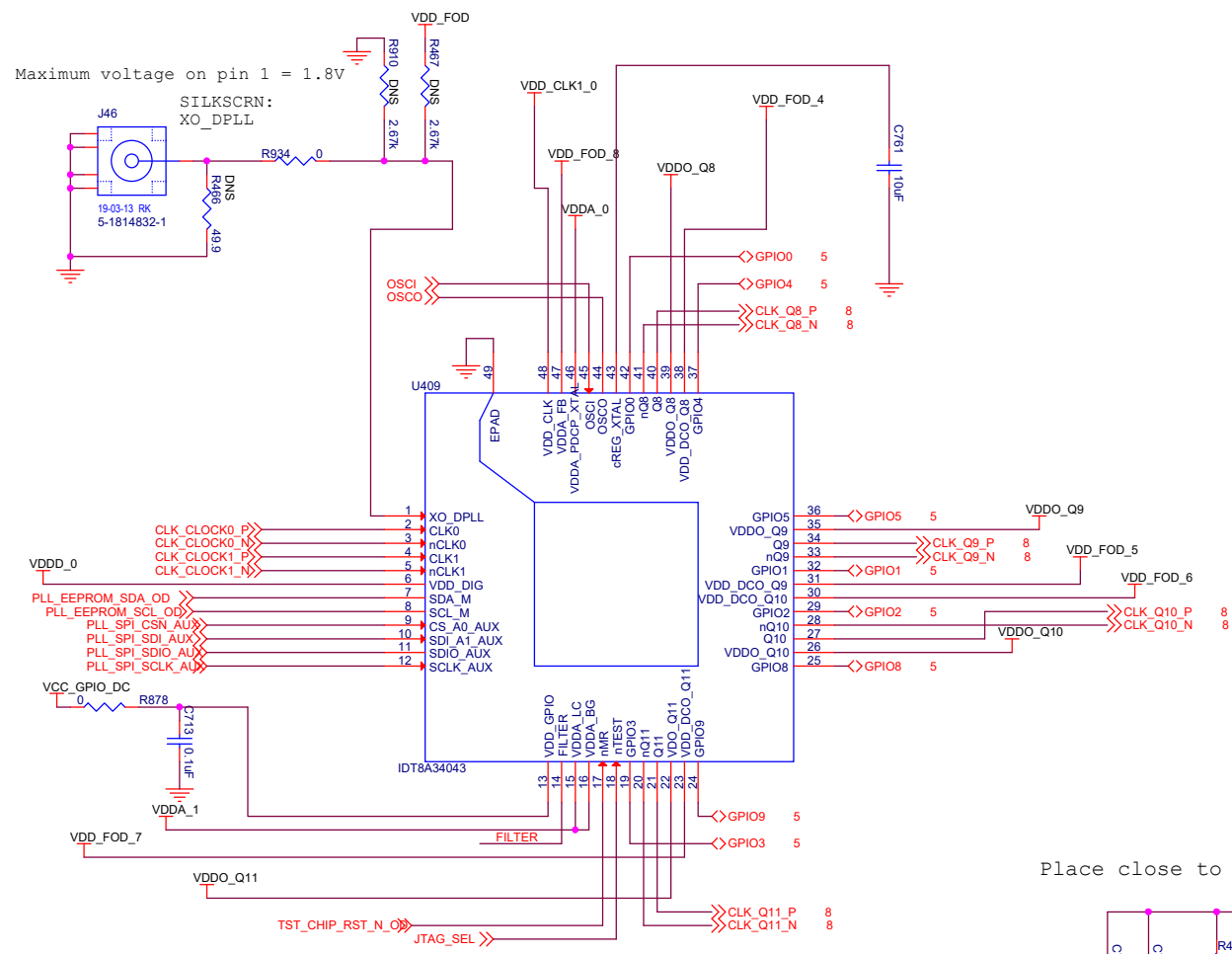

Place close to ClockMatrix

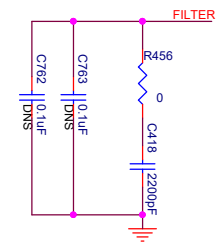

Title		
<Title>		
Size	Document Number	Rev
C	<Doc>	<Rev Code>
Date:	Wednesday, July 08, 2020	Sheet 1 of 1

Board 3V3

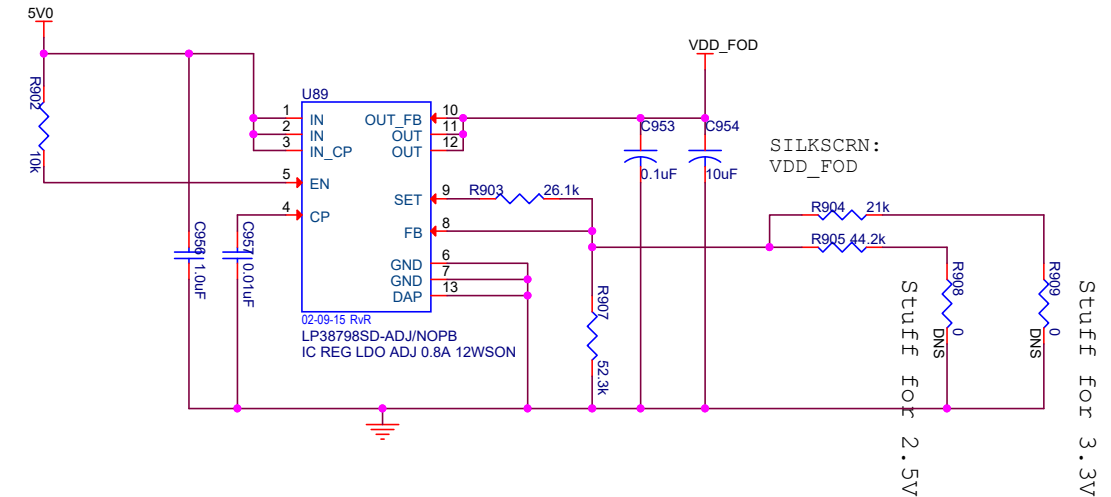
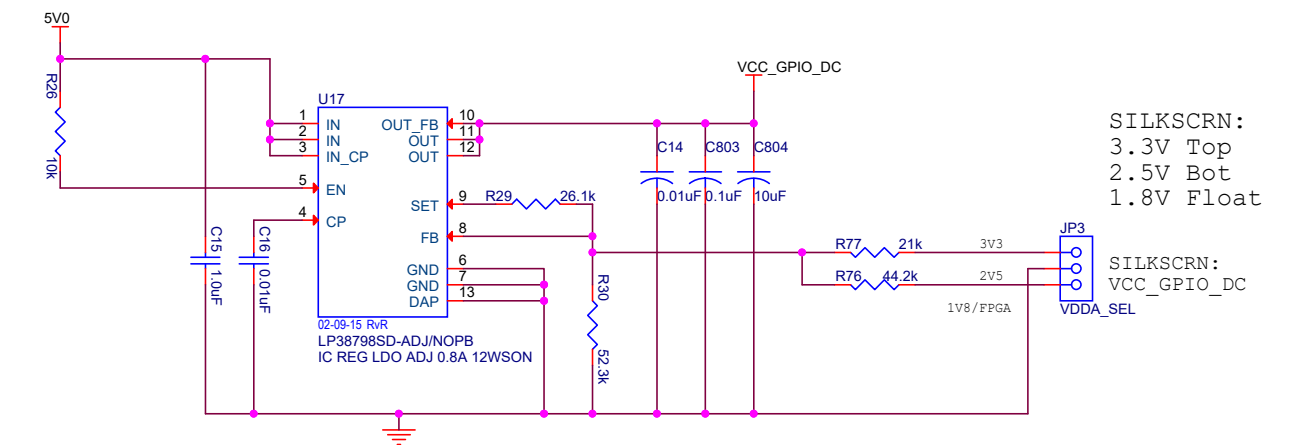
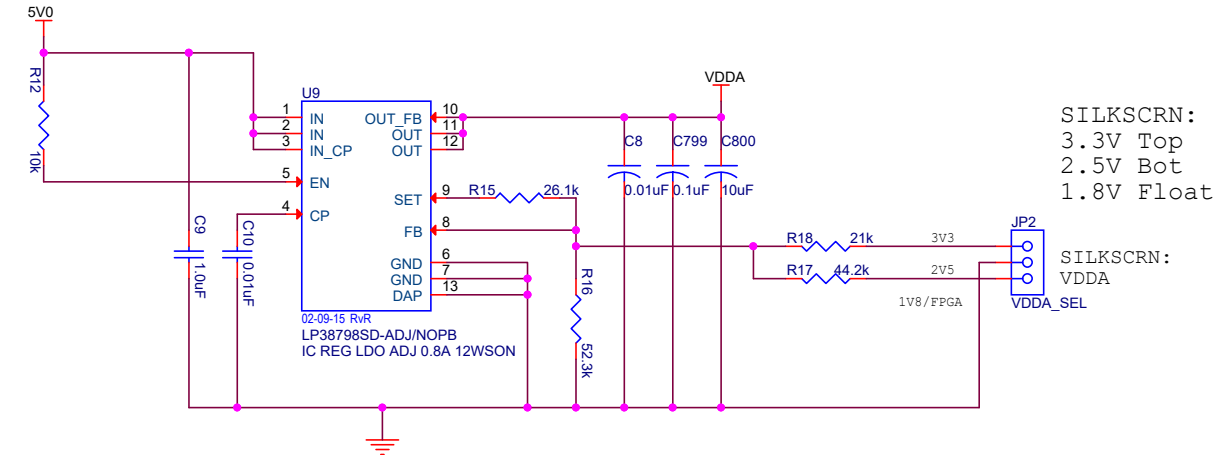
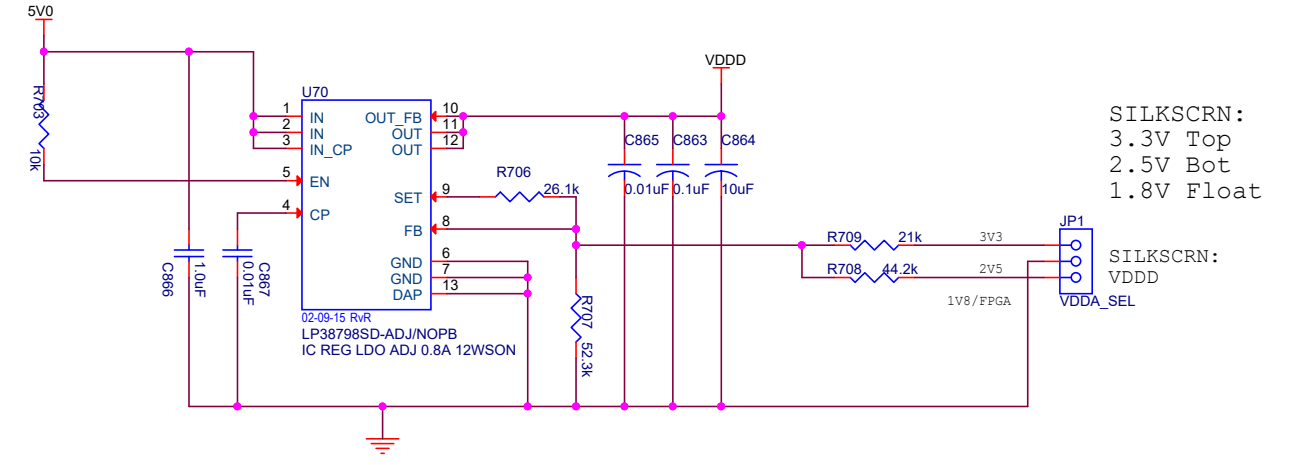
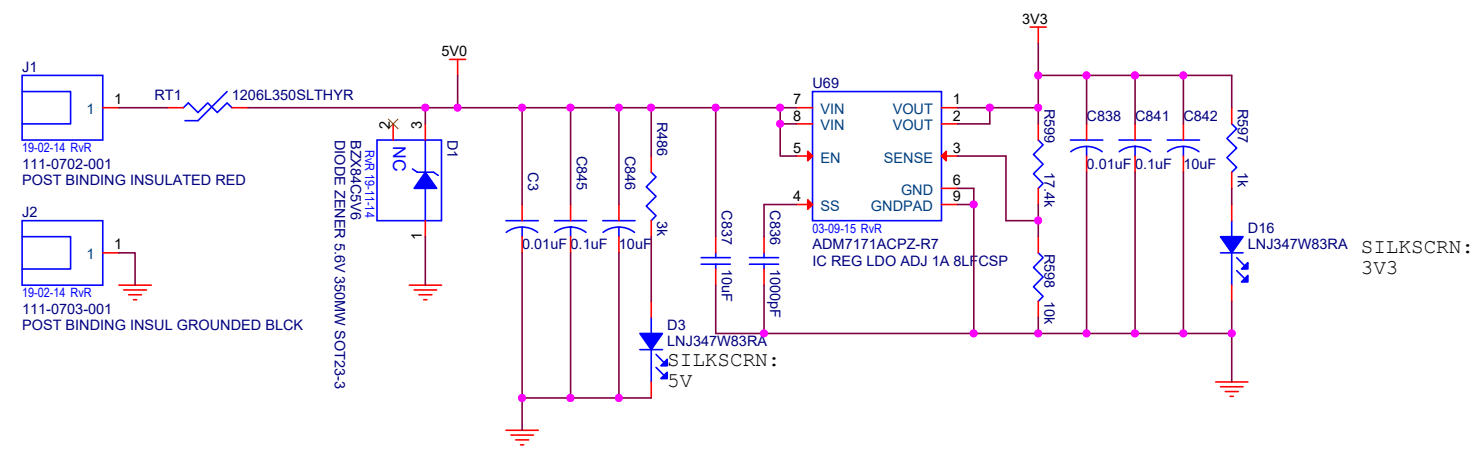

PROJECT NAME	Indira3		Fidus Systems	
DESIGN	DB		375 Terry Fox Drive, Ottawa, ON K2K 0J8	
TITLE	IDT8A34043			
SUBTITLE	Power Supplies 1			
DRAWING NUMBER	SK-10280-01	REVISION	1.2	
RELEASE DATE	27 October 2016	SHEET	2 OF 9	

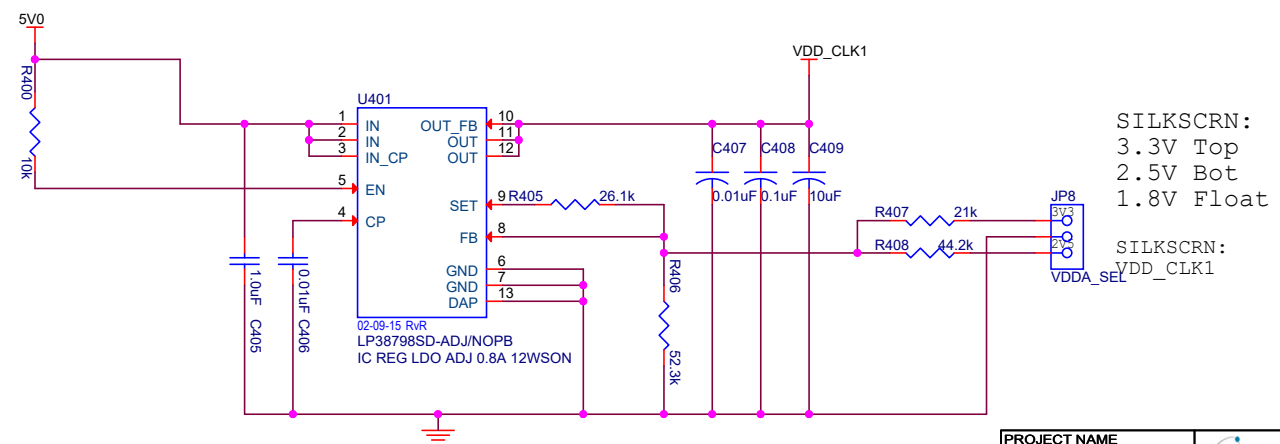
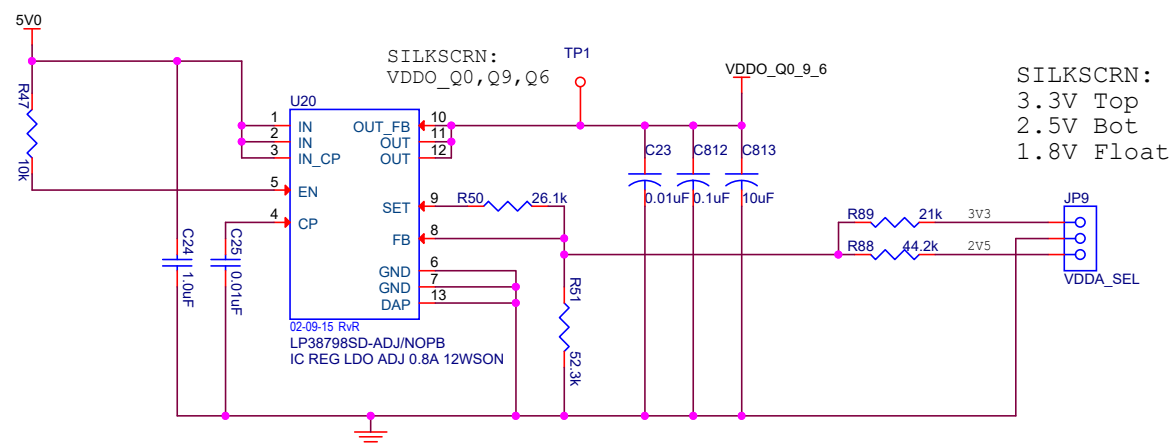
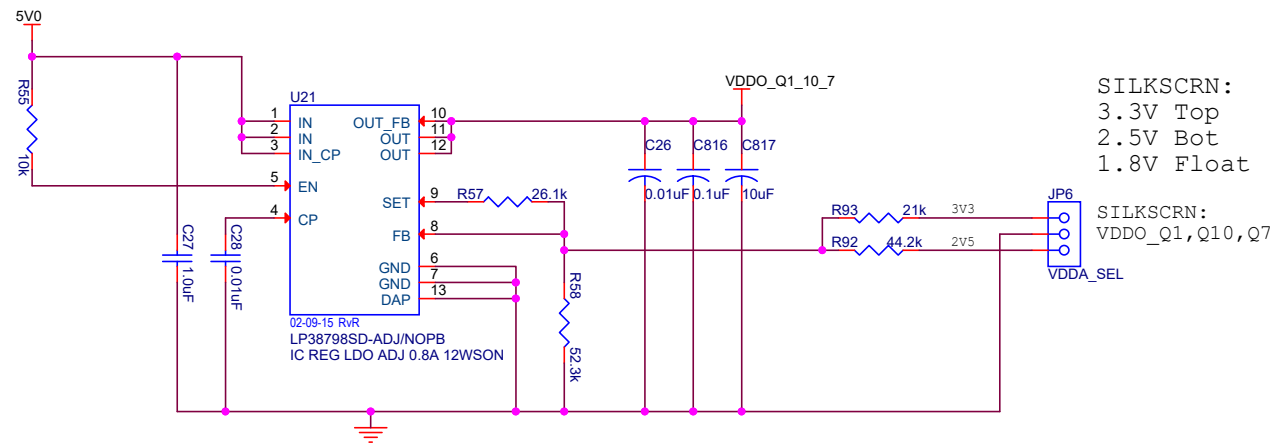
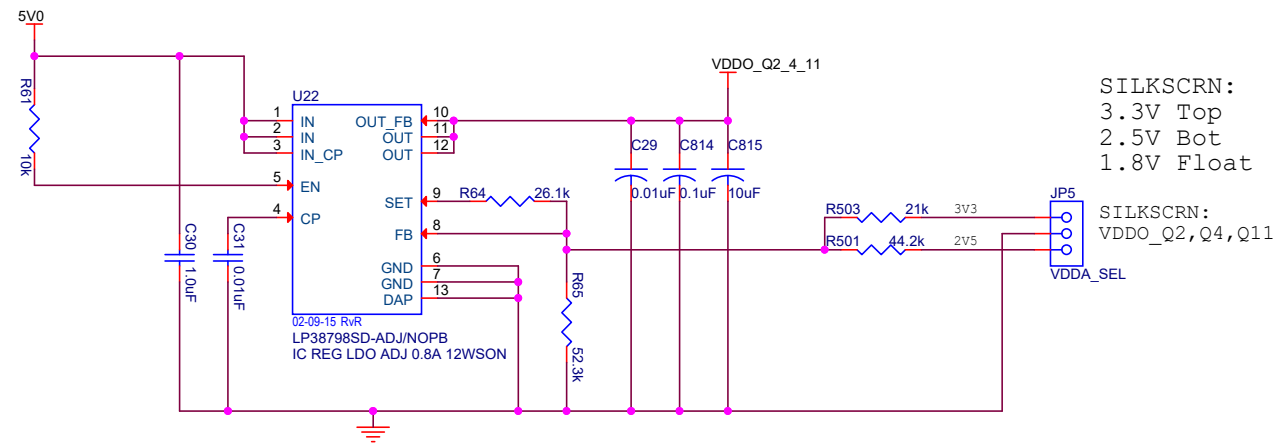
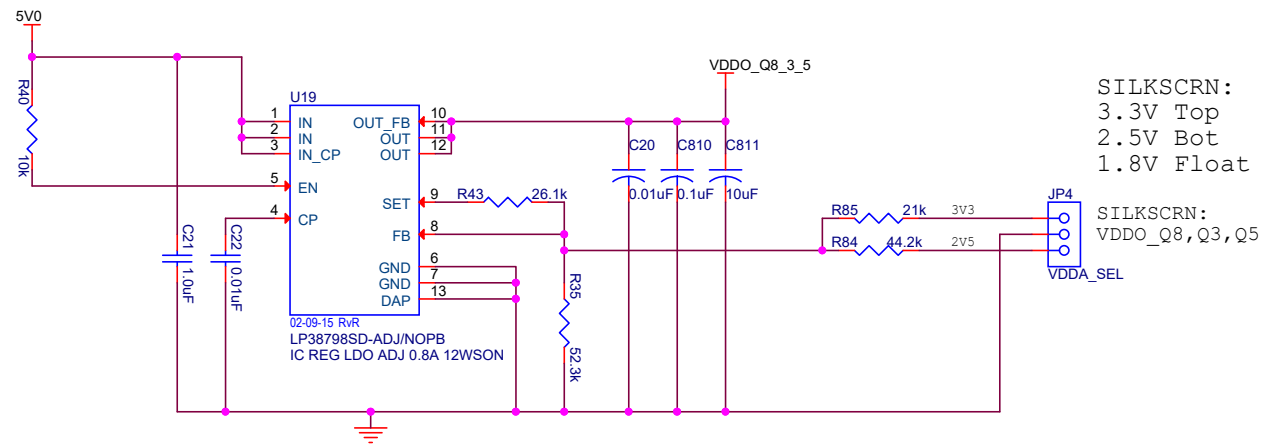

PROJECT NAME	Indira3		Fidus Systems 375 Terry Fox Drive, Ottawa, ON K2K 0J8	
DESIGN	TITLE IDT8A34043			
DB	SUBTITLE Power Supplies 2			
DRAWN	DRAWING NUMBER SK-10280-01			REVISION 1.2
CHECK	RELEASE DATE 27 October 2016			SHEET 3 OF 9
DB				

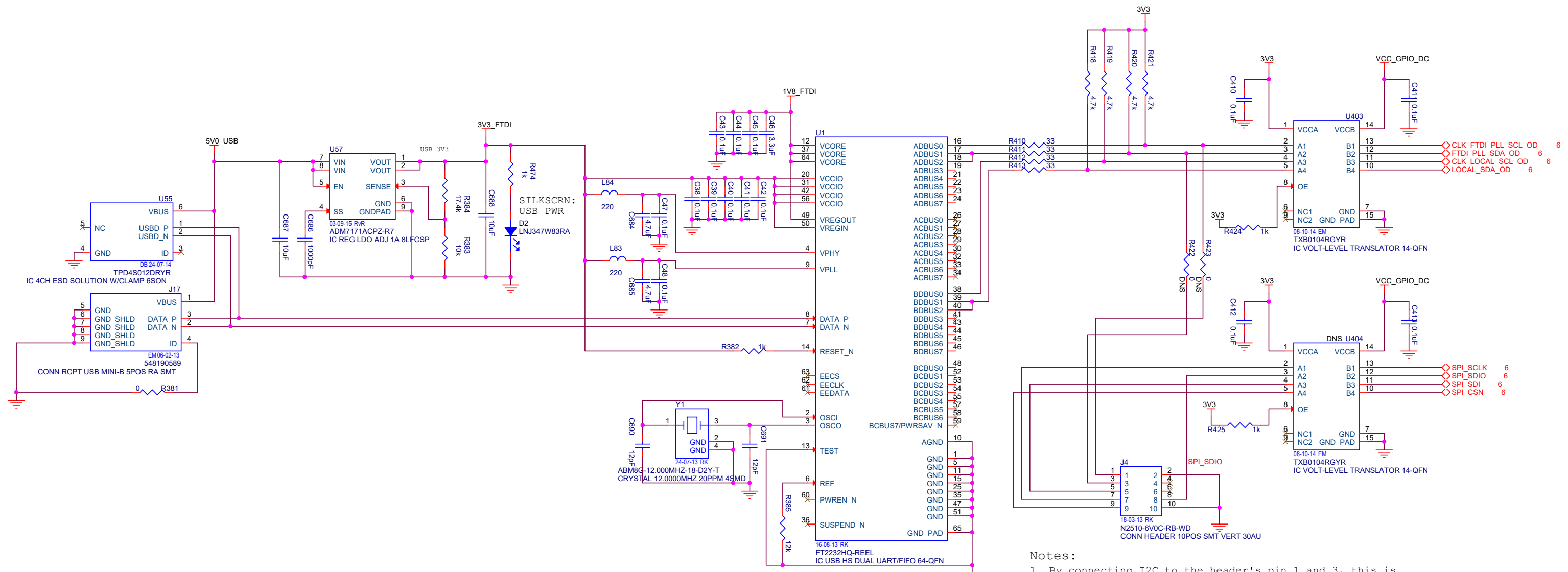

**Notes:**

1. By connecting I2C to the header's pin 1 and 3, this is to give I2C access to external I2C master;
2. By installing R926 and R927, FTDI can also access Aux I2C port (also removing R87 and R88). This feature is not expected to be used.
3. Normal use: FTDI controls I2C port; Header is connected to Aux port in SPI configuration.

PROJECT NAME	Indira3		<b>Fidus Systems</b> 375 Terry Fox Drive, Ottawa, ON K2K 0J8	
DESIGN	TITLE			
DB	<b>IDT8A34043</b>			
DRAWN	SUBTITLE			
DB	<b>FTDI USB Interface</b>			
CHECK	DRAWING NUMBER			REVISION
DB	<b>SK-10280-01</b>			<b>1.2</b>
	RELEASE DATE			SHEET
DB	<b>27 October 2016</b>			<b>4 OF 9</b>

Note for Silkscreen:  
Place GPIO[x] label close to each  
corresponding LED and Test point.

- 6 GPIO0 <- GPIO0
- 6 GPIO1 <- GPIO1
- 6 GPIO2 <- GPIO2
- 6 GPIO3 <- GPIO3
- 6 GPIO4 <- GPIO4
- 6 GPIO5 <- GPIO5
  
- 6 GPIO8 <- GPIO8
- 6 GPIO9 <- GPIO9

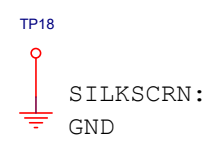
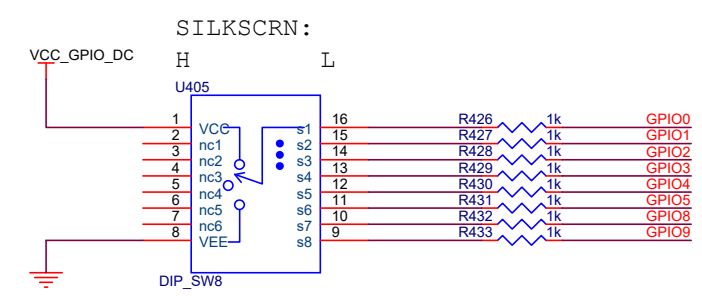
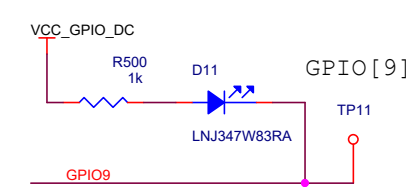
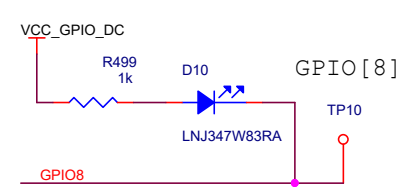
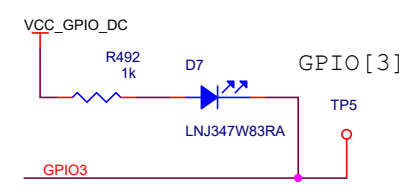
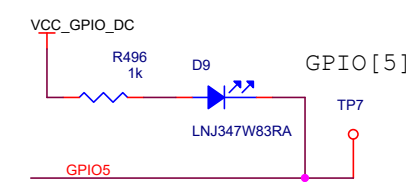
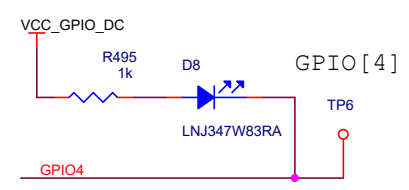
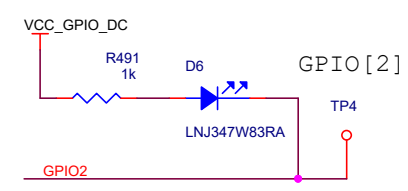
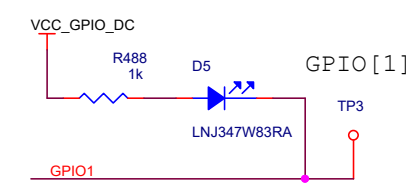
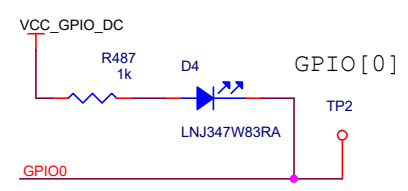

PROJECT NAME	Indira3	fidus	Fidus Systems
DESIGN	RK	375 Terry Fox Drive, Ottawa, ON K2K 0J8	
DRAWN	RK	IDT8A34043	
CHECK	DB	GPIO LEDs	
		DRAWING NUMBER	REVISION
		SK-10280-01	1.2
		RELEASE DATE	SHEET
		27 October 2016	5 OF 9

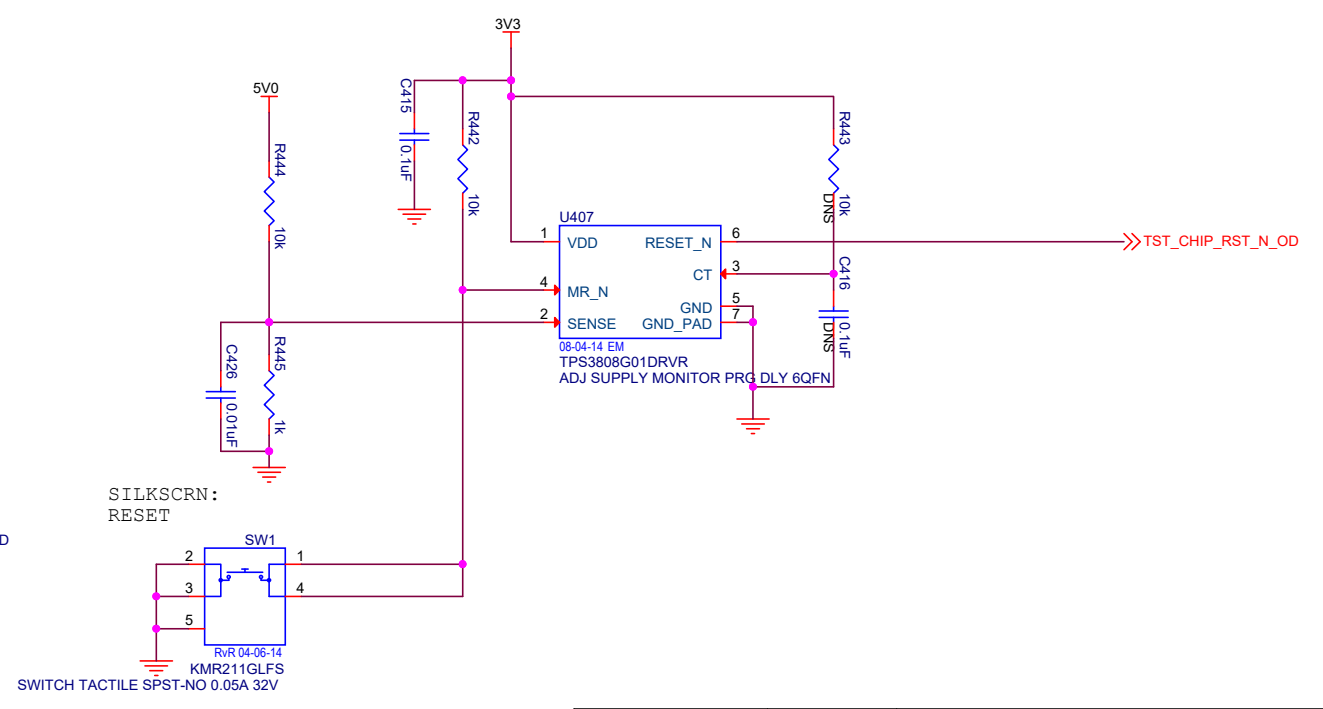
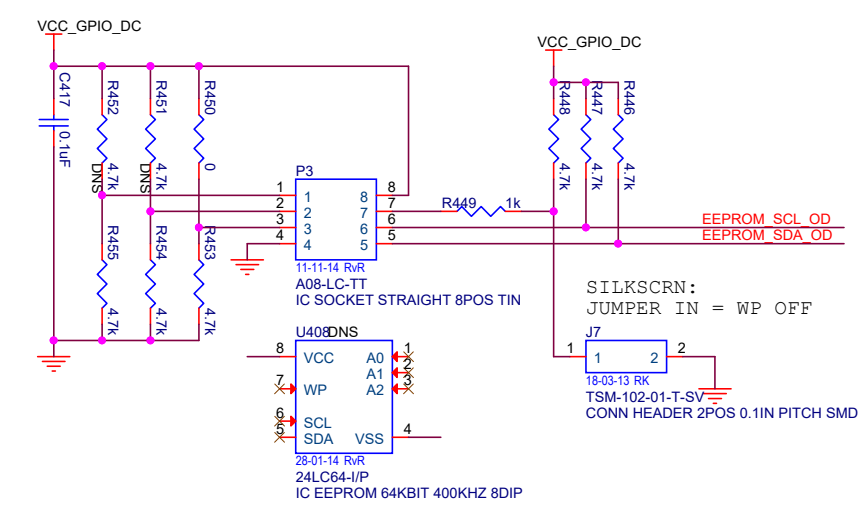
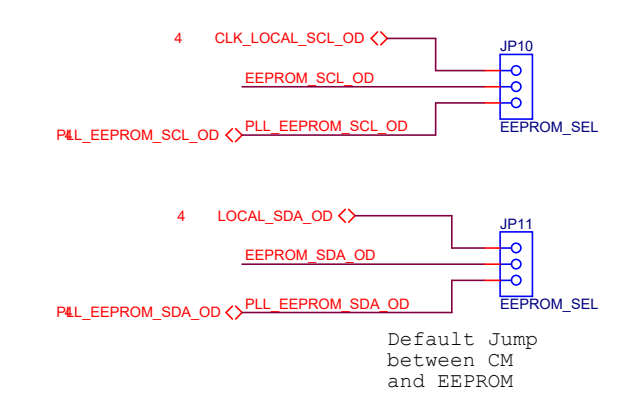
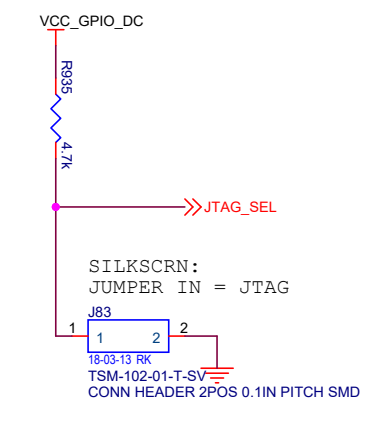
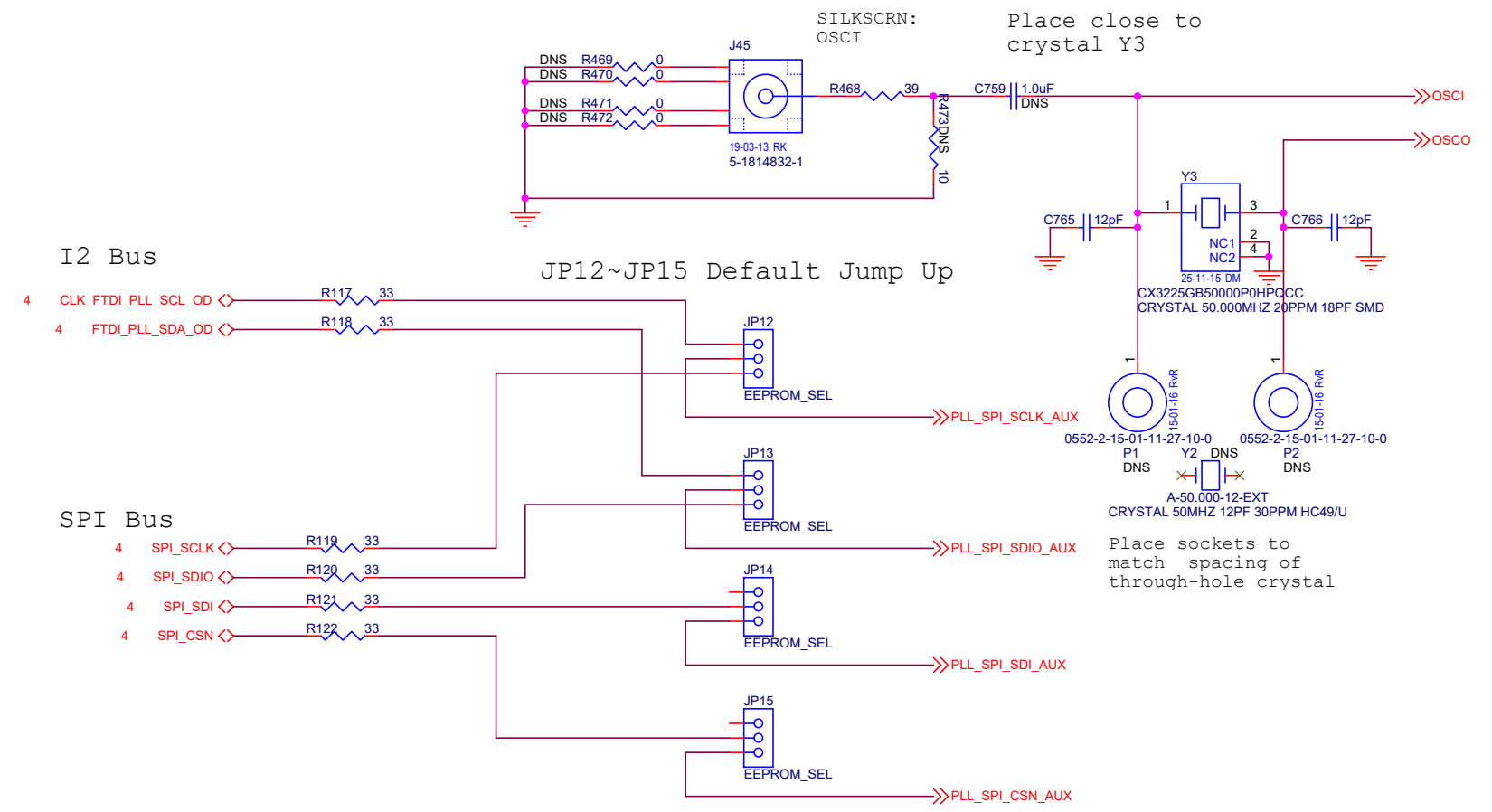

PROJECT NAME	Indira3		Fidus Systems
DESIGN	DB	375 Terry Fox Drive, Ottawa, ON K2K 0J8	
TITLE	IDT8A34043		
SUBTITLE	PLL Core		
DRAWING NUMBER	SK-10280-01	REVISION	1.2
RELEASE DATE	27 October 2016	SHEET	6 OF 9

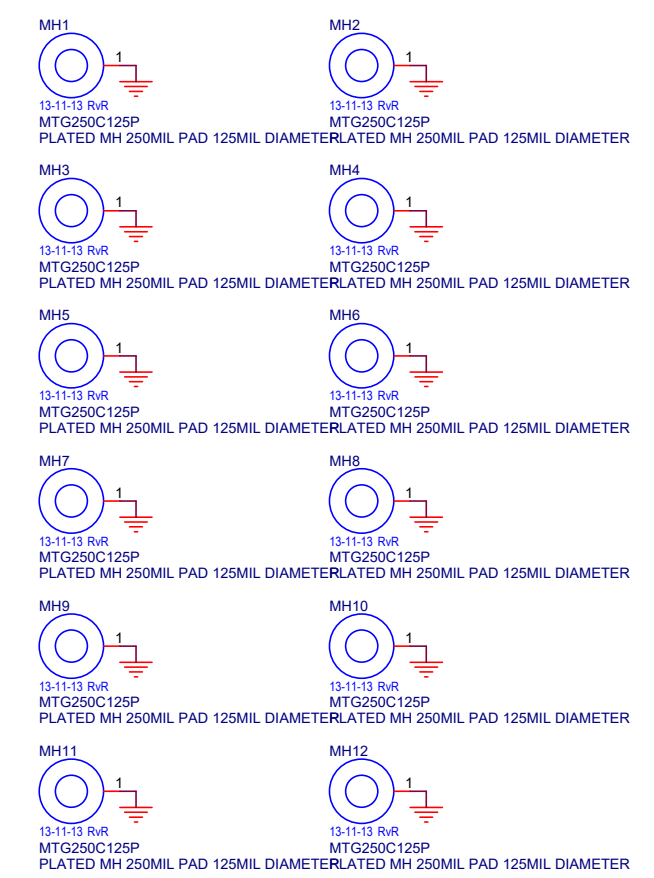
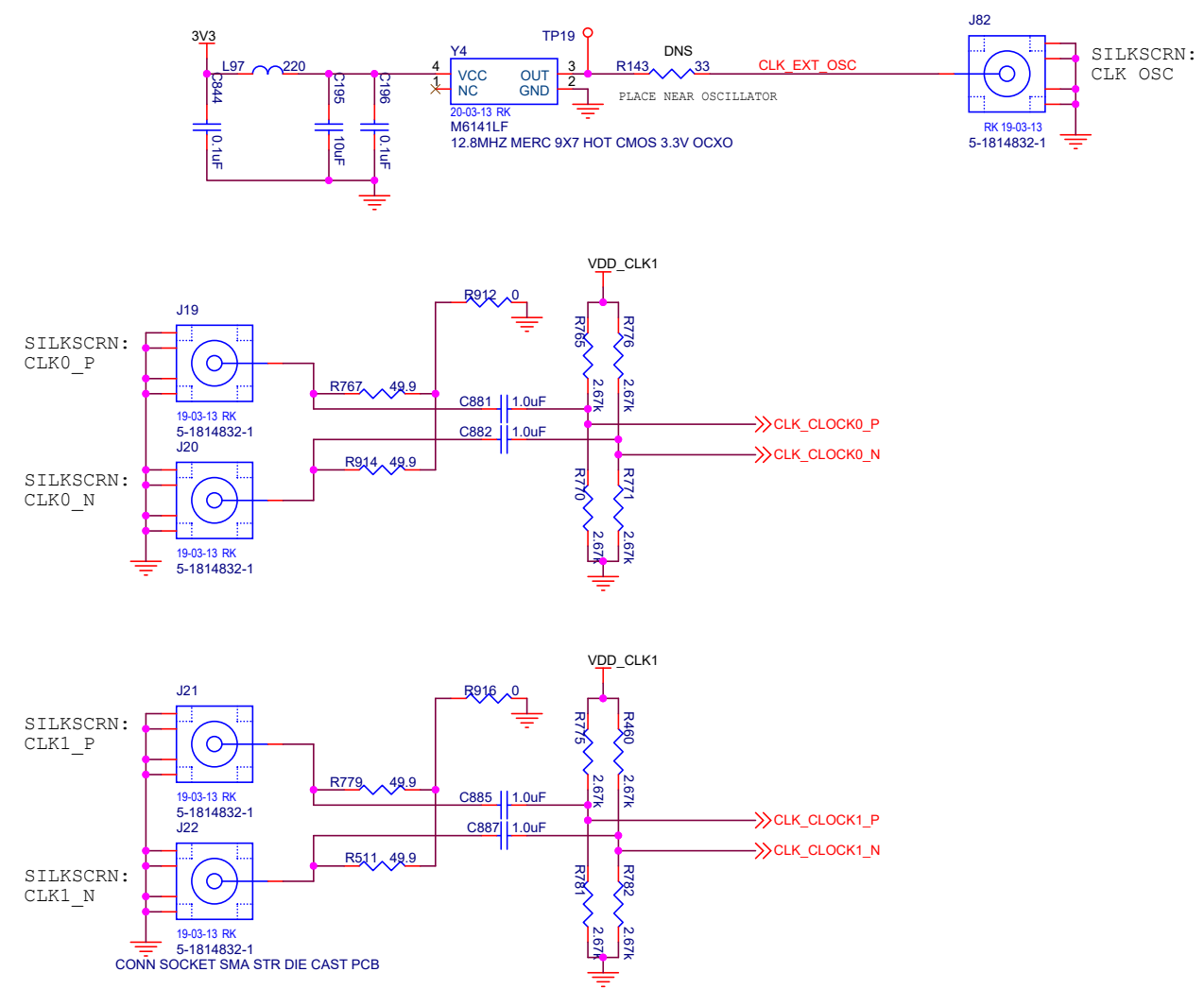

PROJECT NAME		Indira3		 <b>Fidus Systems</b> 375 Terry Fox Drive, Ottawa, ON K2K 0J8	
DESIGN		TITLE			
RK		<b>IDT8A34043</b>			
DRAWN		SUBTITLE			
RK		PLL Input Clocks			
CHECK		DRAWING NUMBER		REVISION	
DB		SK-10280-01		1.2	
		RELEASE DATE		SHEET	
		27 October 2016		7 OF 9	



PLACE PARALLEL  
TERMINATIONS  
CLOSE TO U58

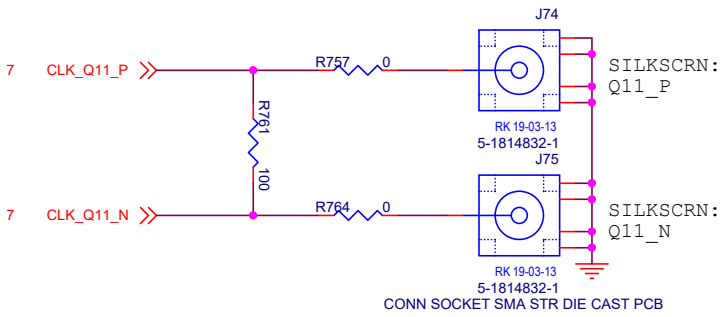
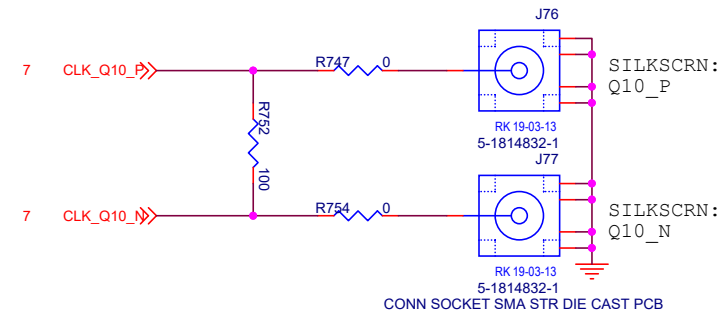
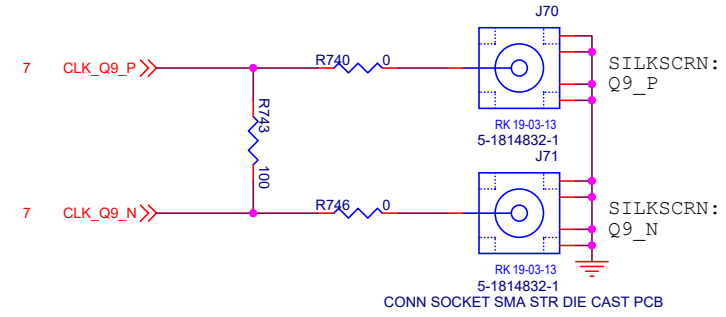
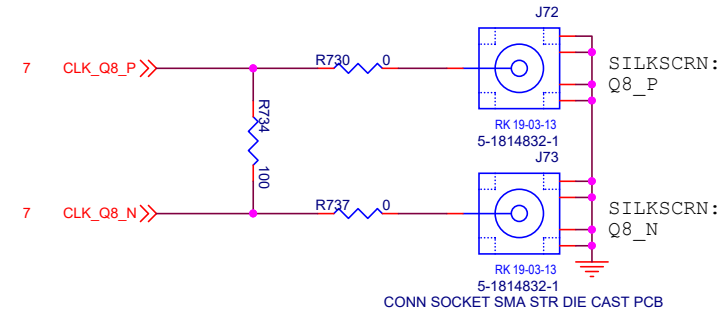

PROJECT NAME	Indira3		 <b>Fidus Systems</b> 375 Terry Fox Drive, Ottawa, ON K2K 0J8	
DESIGN	TITLE			
DB	IDT8A34043			
DRAWN	SUBTITLE			
DB	PLL Output Clocks			REVISION
CHECK	DRAWING NUMBER		1.2	
DB	SK-10280-01		RELEASE DATE	
DB	27 October 2016		SHEET	8 OF 9

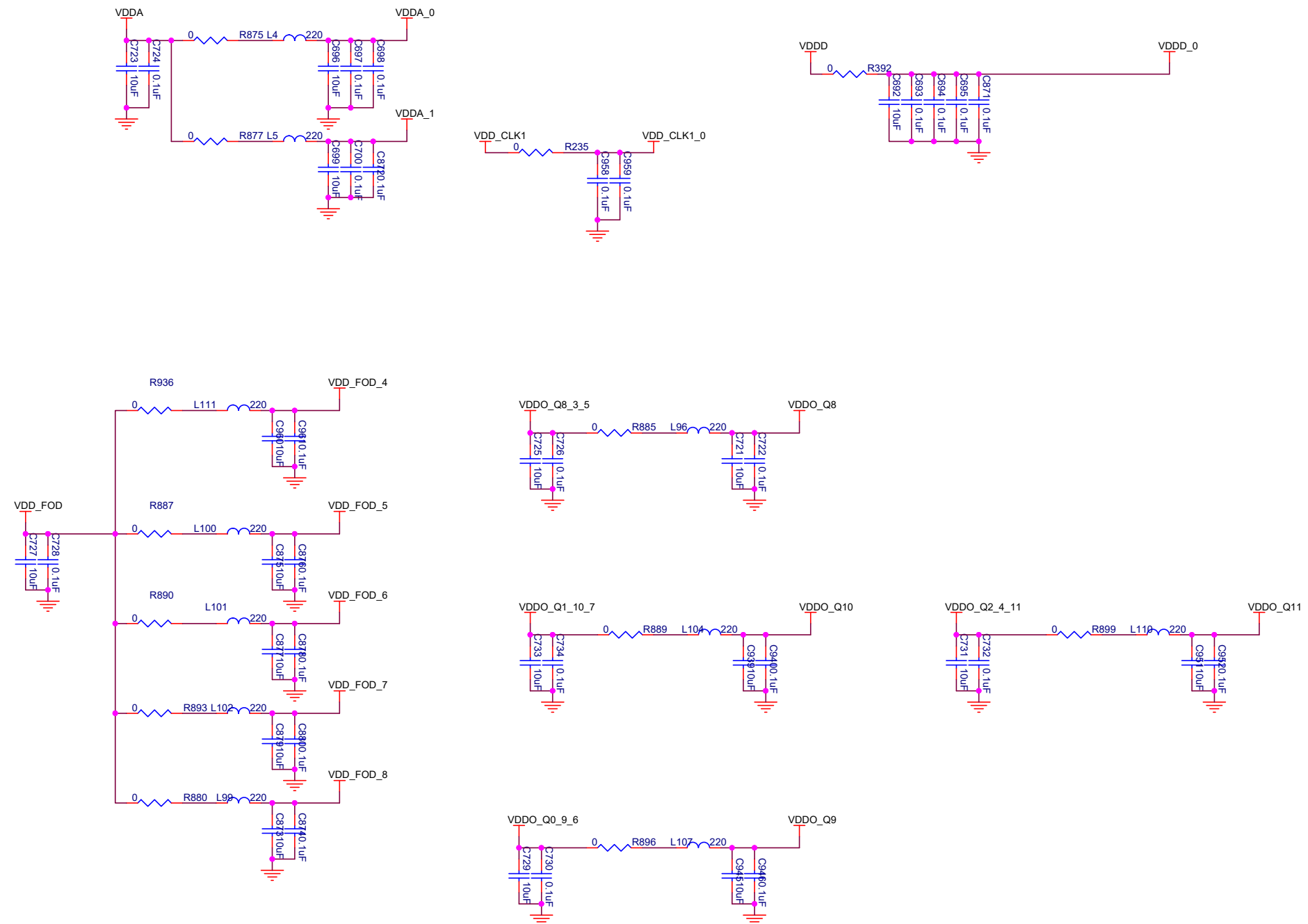

PROJECT NAME	Indira3		Fidus Systems 375 Terry Fox Drive, Ottawa, ON K2K 0J8	
DESIGN	TITLE IDT8A34043			
DRAWN	SUBTITLE PLL Power			
CHECK	DRAWING NUMBER SK-10280-01		REVISION 1.2	
DB	RELEASE DATE 27 October 2016		SHEET 9 OF 9	