

# DA14683 USB KIT

Design Name	DA14683_USB_KIT_vC
Ref. Number	224-46-C
Version	C
Date	27 Mar. 2018
Designer	Panagiotis Golfopoulos

Configuration note

NOTE box

Changes on this version



T1 Label\_Dialog\_L6008

TP23 FIDUCIAL

TP24 FIDUCIAL

Version	Date	Comments
A00	18 / Dec. / 2017	Initial Schematic
B00	6 / Mar. / 2018	<p>Changes to current version:</p> <ul style="list-style-type: none"> <li>- Change part Y3 to 9HT11-32.768KDZB-T</li> <li>- Change T25 to Header conn. type</li> <li>- Add TP25 for monitoring 5V</li> <li>- Add TP26 for monitoring VDD_3V3_SEG</li> </ul> <p>Antenna matching circuit:</p> <ul style="list-style-type: none"> <li>- R84 change to Z3 = 10pF</li> <li>- R85 change to L2 = 2.2nH</li> <li>- R86 change to L3 = 4nH</li> <li>- Z1 change to R88 (NP)</li> <li>- Z2 change to R89 (0ohm)</li> </ul> <p>Change MikroBus power supply from VDD_3V3_SEG to VDD_3V3_HUB                      Change RESET circuit                      Set Resistor R9 as populated (1kohm)                      Set resistor R10 as No populated</p>
C00	29 / Mar. / 2018	<p>Changes to current version:</p> <ul style="list-style-type: none"> <li>- Remove J2 (Segger connector)</li> <li>- Add TP30 (SWO/TDO)</li> <li>- Add TP28 (LDO_683)</li> <li>- Add TP29 (V33)</li> <li>- Add SW6</li> <li>- Add U10</li> <li>- Add 1uF Cap C50 &amp; C51</li> <li>- Remove R49, R50</li> <li>- Change R87 from 4.7k to 1k</li> </ul>

<Variant Name>



Dialog Semiconductor  
 N.E.O. Athinon- Patron 15  
 26441, Patra, Greece  
 tel. (+30) 2610390940  
 fax. (+30) 2610390941

Title : DA14683 USB KIT vC		
Doc. Nr. 224-46-C	Designer: Panagiotis Golfopoulos	Rev: C
Date: Thursday, March 29, 2018	Sheet: 1 of 5	

**D2/C1  
VOLTAGE  
RATE  
MUST BE > 20V**

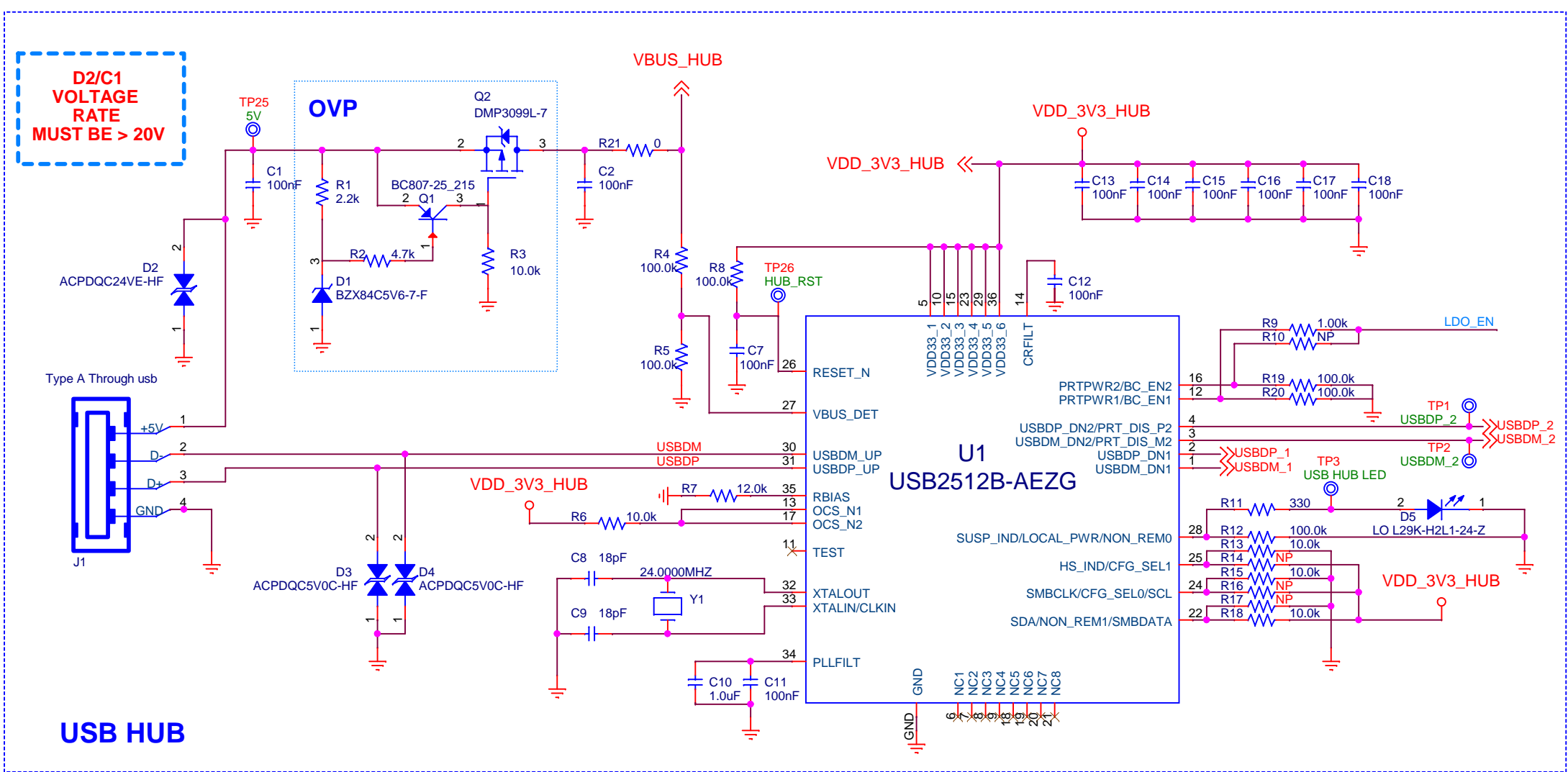

**USB HUB**

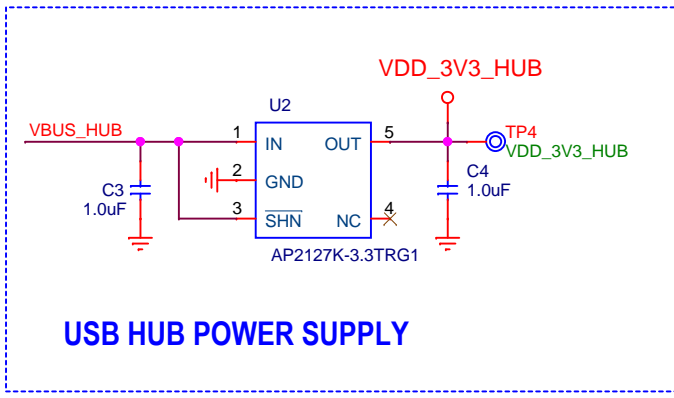

**USB HUB POWER SUPPLY**

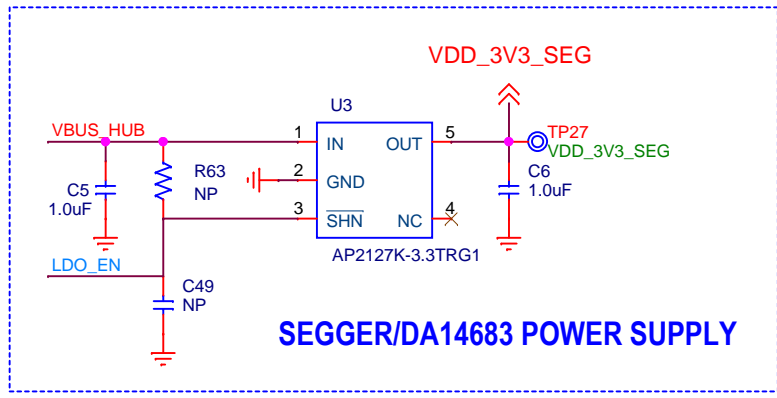

**SEGGER/DA14683 POWER SUPPLY**

<Variant Name>

**dialog**  
SEMICONDUCTOR

Dialog Semiconductor  
N.E.O. Athinon- Patron 15  
26441, Patra, Greece  
tel. (+30) 2610390940  
fax. (+30) 2610390941

Title: <b>DA14683 USB KIT vC</b>		
Doc. Nr. 224-46-C	Designer: Panagiotis Goulinopoulos	Rev: C
Date: Thursday, March 29, 2018	Sheet: 2	of 5

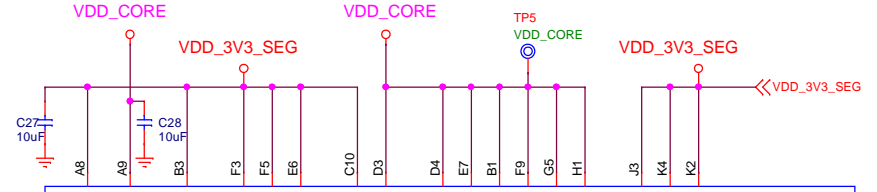
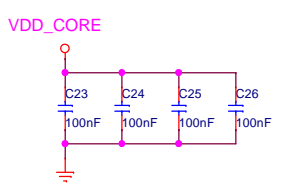
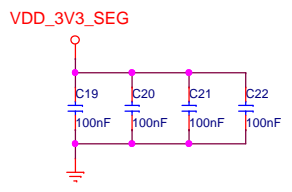

Needed for Segger software

TRSTin  
TRSTout

TDlin  
TDIout

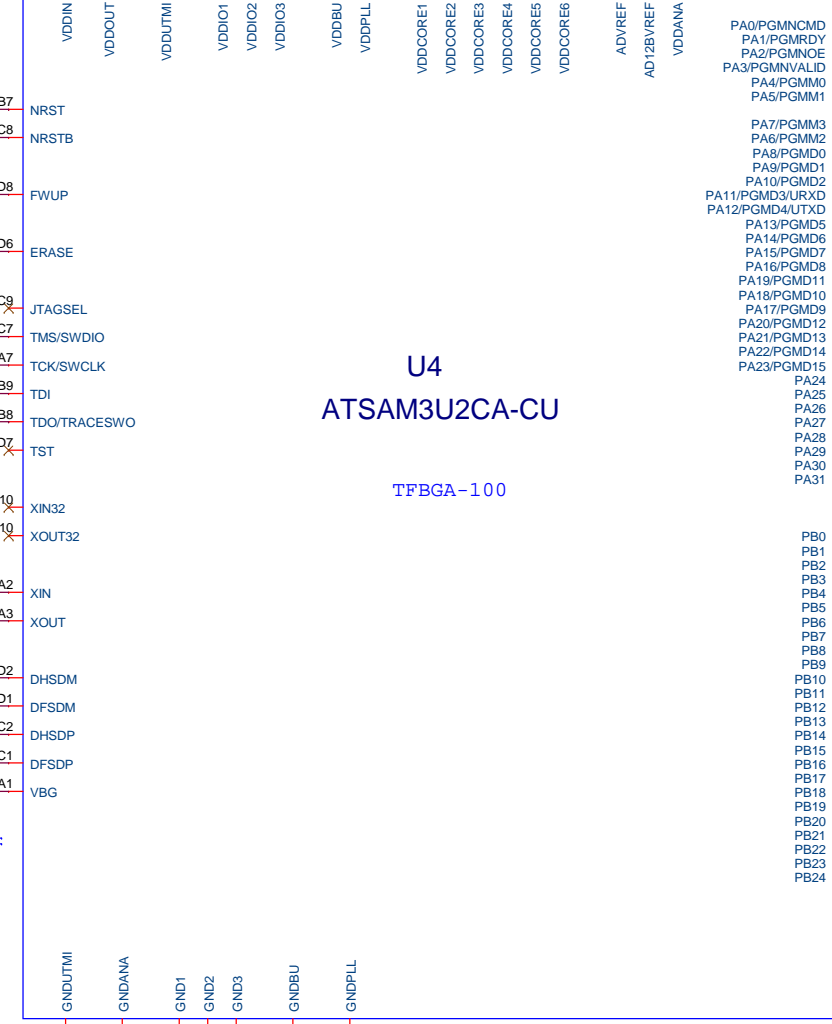
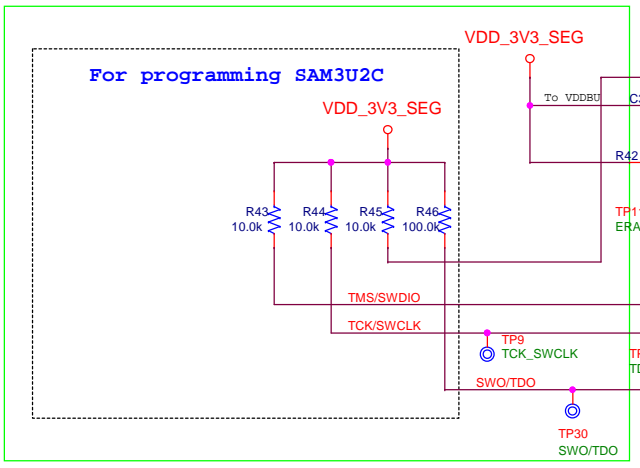

U4  
ATSAM3U2CA-CU  
TFBGA-100

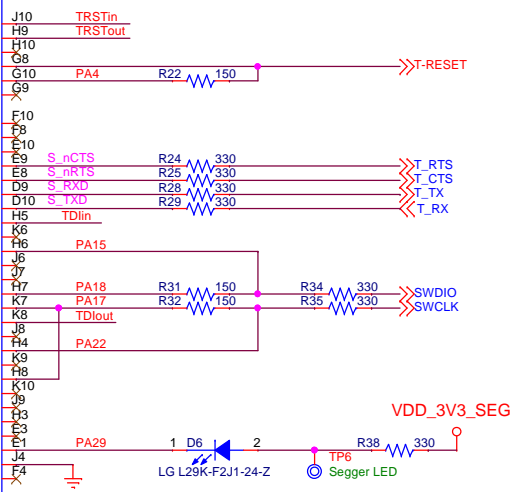

<Variant Name>

Dialog Semiconductor  
N.E.O. Athinon- Patron 15  
26441, Patra, Greece  
tel. (+30) 2610390940  
fax. (+30) 2610390941

Title : DA14683 USB KIT vC  
Doc. Nr. 224-46-C | Designer: Panagiotis Goulinopoulos | Rev: C  
Date: Thursday, March 29, 2018 | Sheet: 3 of 5

### QUAD SPI FLASH

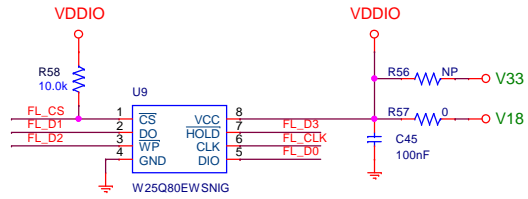

### DA14683 RESET CIRCUIT

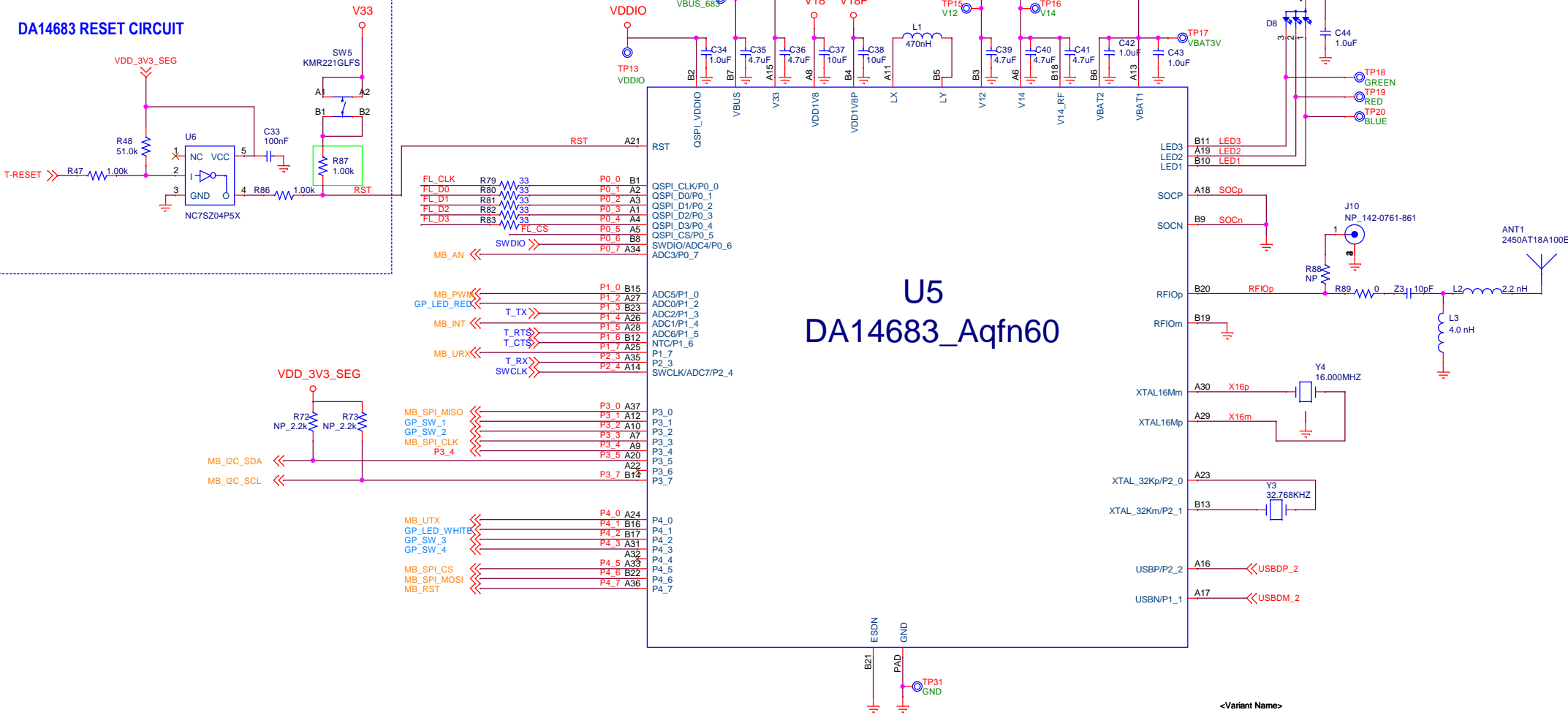
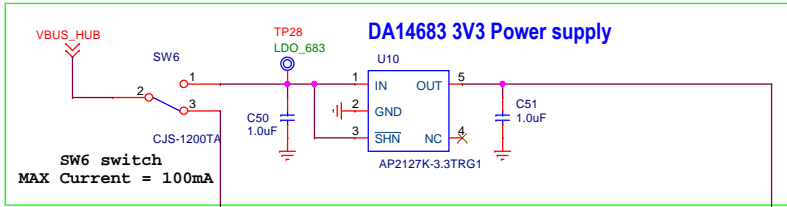
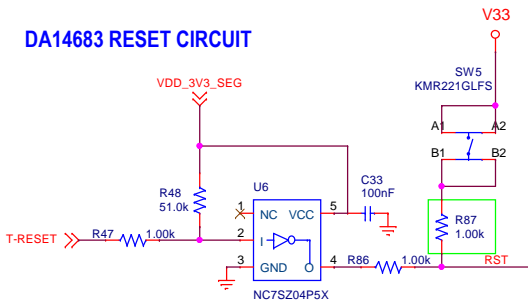

## U5 DA14683\_Aqfn60

<Variant Name>

Dialog Semiconductor  
N.R.O. Athinon- Patron 15  
26441, Patra, Greece  
tel. (+30) 2610390940  
fax. (+30) 2610390941

Title :	DA14683 USB KIT vC	Doc. Nr.	224-46-C	Designer:	Panagiotis Gollinopoulos	Rev.C
Date:	Thursday, March 29, 2018	Sheet:	4	of	5	

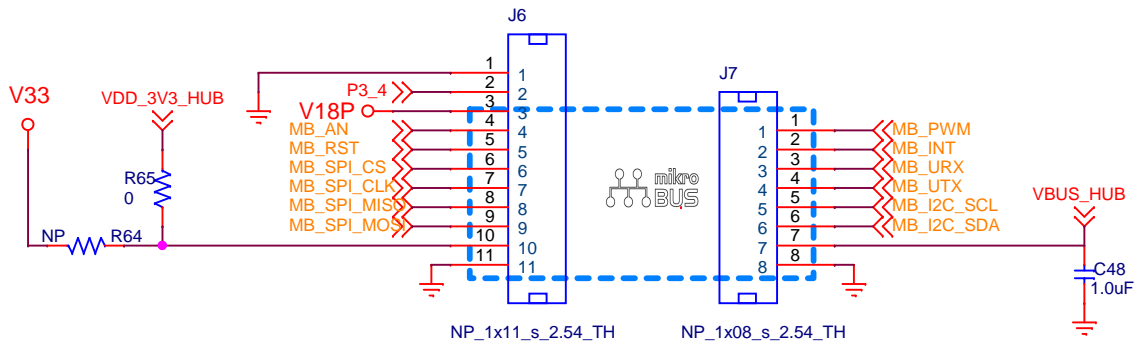

### MIKROBUS & GENERAL PURPOSE CONNECTORS

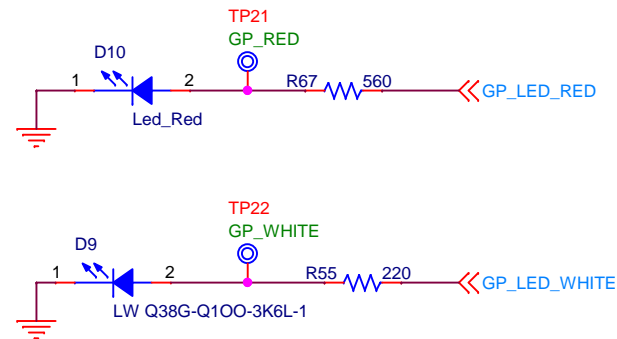

### GENERAL PURPOSE LEDs

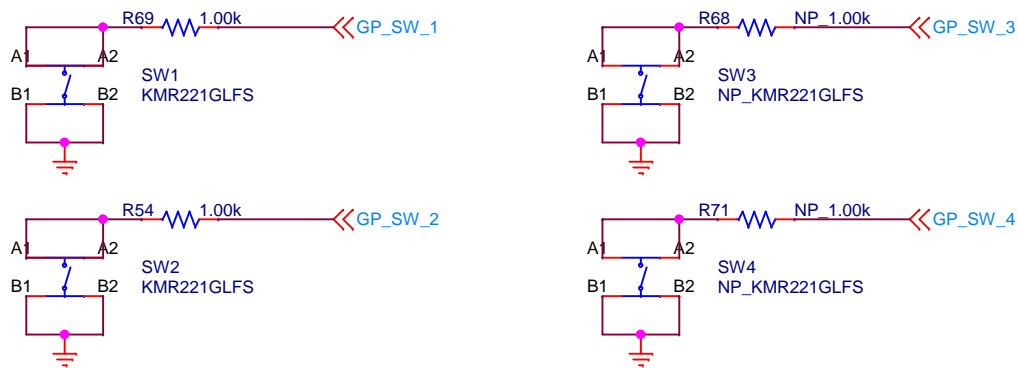

### GENERAL PURPOSE SWITCHES

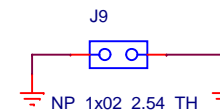

### GND SUPPORT POINT

<Variant Name>



Dialog Semiconductor  
 N.E.O. Athinon- Patron 15  
 26441, Patra, Greece  
 tel. (+30) 2610390940  
 fax. (+30) 2610390941