

DA1469x Reference Design

Design Name	2522-db-vfbga100
Ref. Number	331-06-E
Version	E
Date	11/Dec/2018
Designer	Panos Raftopoulos

History Table

Version	Date	Comments
	10/Jul/2017	Draft Schematic
	04/Oct/2017	Internal review release
	17/Oct/2017	Formal review release
	02/Nov/2017	Added TP21 (bottom testpoint for V18F) Added D7, D8 (ESD protection on USB Data)
A1.0	03/Nov/2017	Changed printed antenna type to reduced IFA
	07/Nov/2017	Released to manufacturing
A1.1	14/Nov/2017	Changed C6, C7 value to 10uF Changed U1 part number to DA14699-00000HR2
A1.2	22/Mar/2018	Removed R19, changed reset button circuit to directly short to GND Changed C4, C5 part number to GRM188R60J226MEA0D (22uF/6.3V/0603) Changed L1 (DCDC inductor) to DFE201610E-R47M Added pull-down resistor R24 to P1_1 Changed C9 value to 10uF Changed Z1 value to 6.8nH Changed Z2 value to 2.0pF Changed Z3 value to 0.6pF Changed the reference designator for the reset button to K2
B1.0	04/Apr/2018	PCB layout updated to rev.B
	10/Sep/2018	Added a current limiter mosfet on V30 (Q4) -> external loads now connect to the current limited rail (V30x) Corrected the mismatch of the UART signals on J4 Added 0402 NP capacitor close to J3 pin-1 (C14)
C1.0	18/Sep/2018	Released to manufacturing
	23/Oct/2018	Changed C13 value to 2.2uF/25V Changed flash part number to MX25U3235FM2I-10G
D1.0	15/Nov/2018	Modified options for the QSPI flash package: - U2 --> 8SOIC 208mil - U2X --> 8USON 2x3mm - U2Y --> 8SOIC 150mil Changed ESD protection D7 D8 from ESD206B102ELSE6327XTSA1 (EOL) to ESD102U102ELSE6327XTSA1 (note: this part is polarized) Updated several parts as obsoleted/EOL and some with environmental compliance problems (K2, J3)
E1.0	11/Dec/2018	Added 0 ohm resistor (R25) shorting V18F to V18P Changed USB connector (J3) type to Molex 67503-1020 Changed default part# for 4.7uF capacitors to GRM155R61A475MEAAD

Configuration note

NOTE box

Changes in this Version.

—○ TP10 FIDUCIAL
—○ TP11 FIDUCIAL

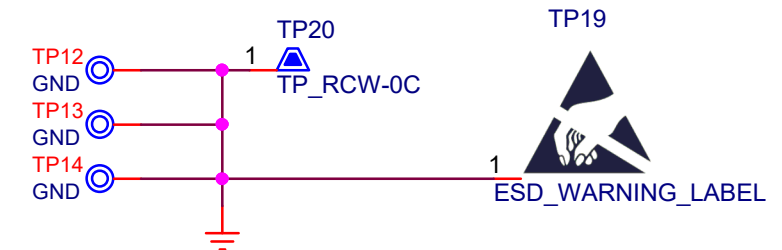

Dialog Semiconductor
N.E.O. Patron-Athinon 15
26441, Patras, Greece
tel. (+30) 2610390940
fax. (+30) 2610390941

Title : DA1469x devkt-pro daughterboard (VFBGA100)

Doc. Nr. 331-06-E Designer: PR Rev: E
Date: Tuesday, December 11, 2018 Sheet: 1 of 3

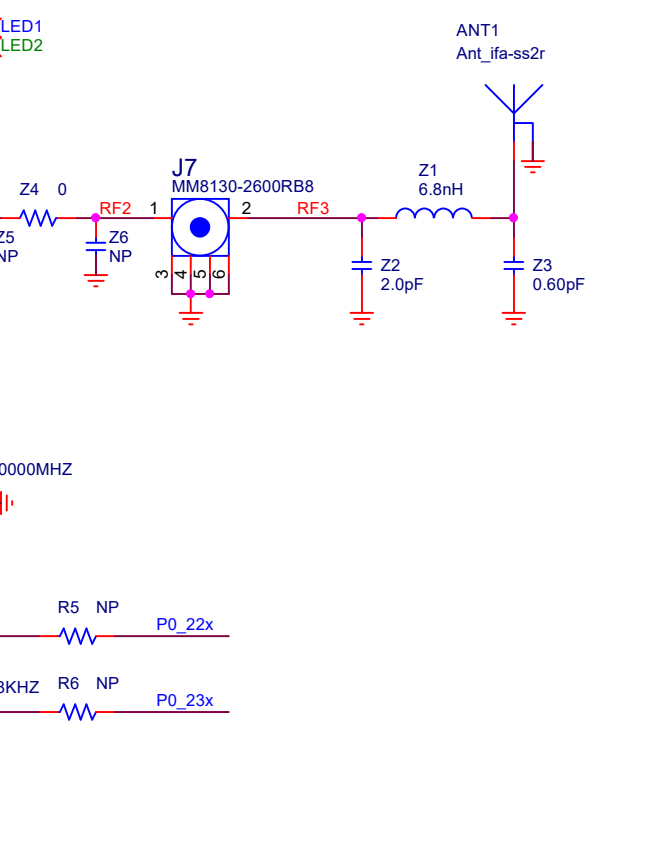
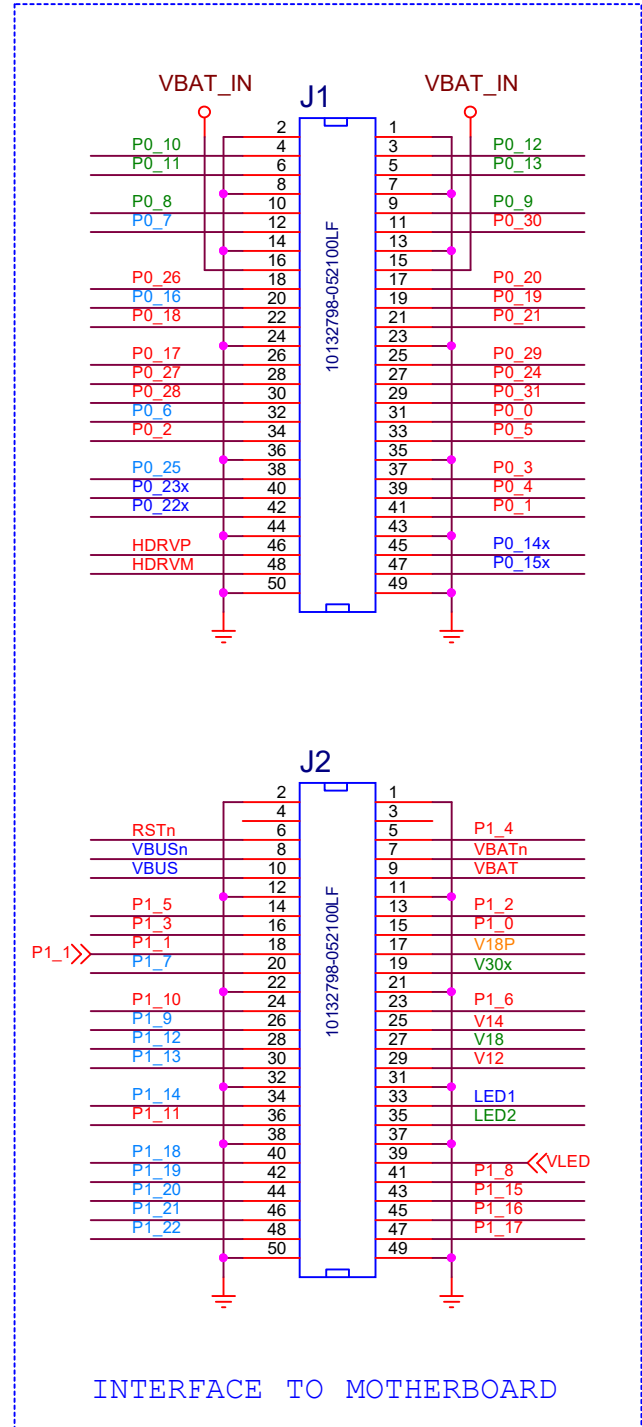
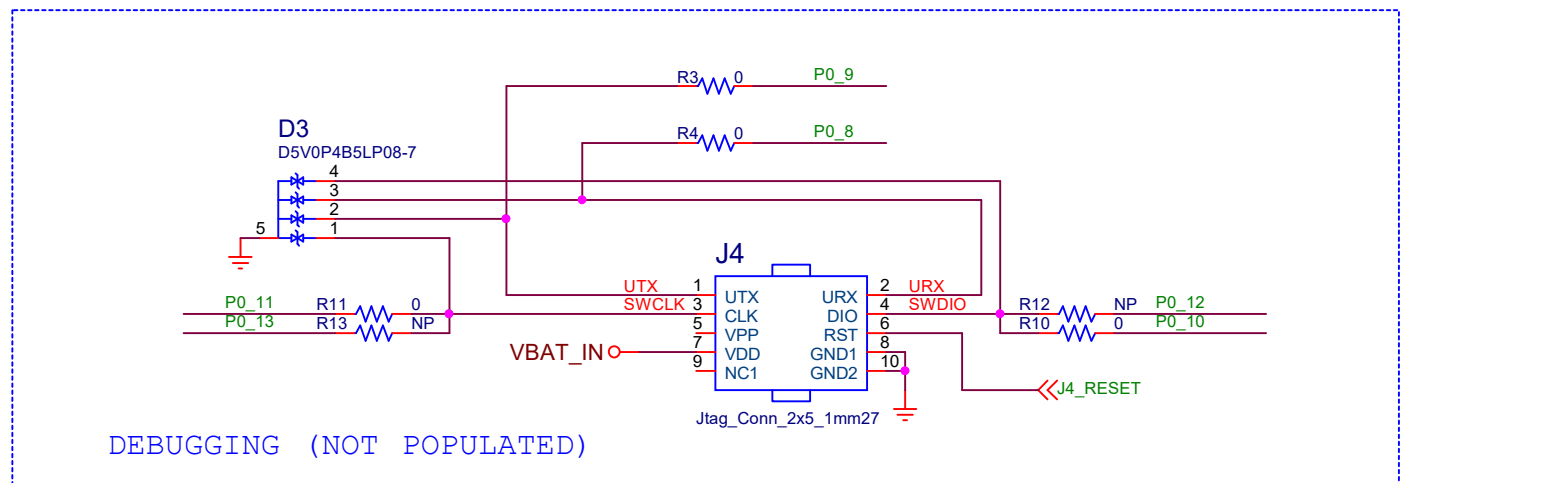
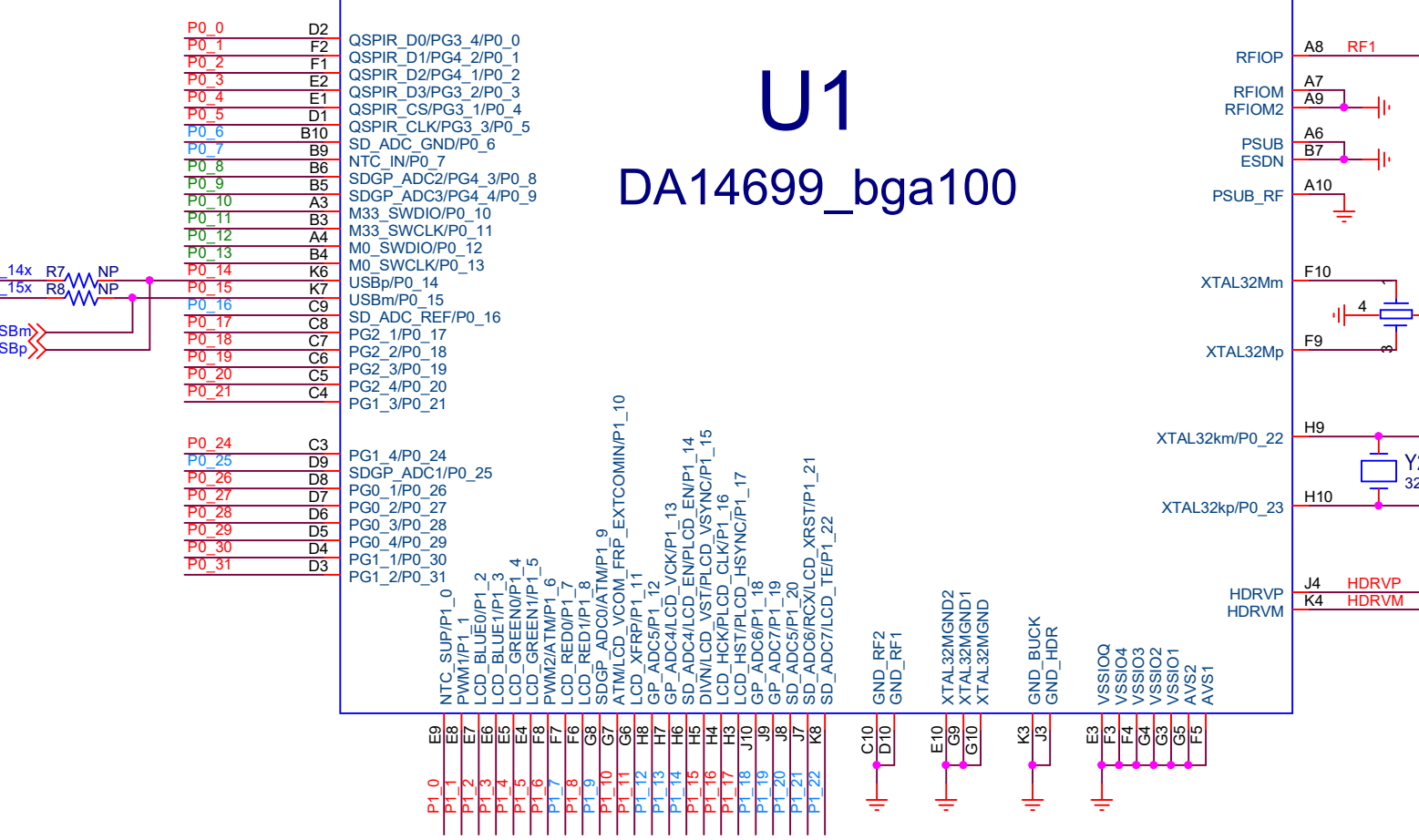
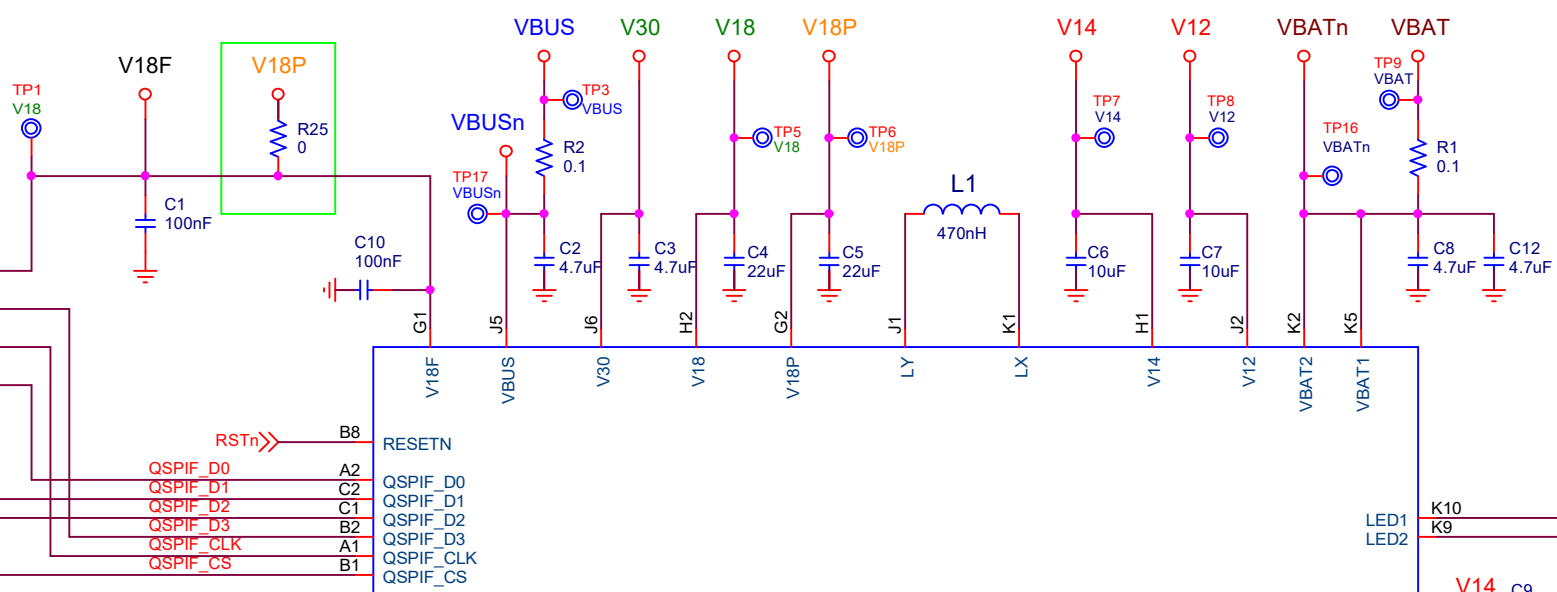
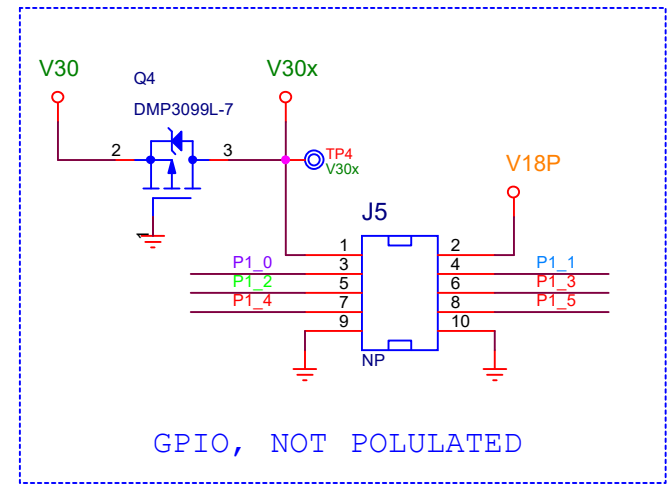

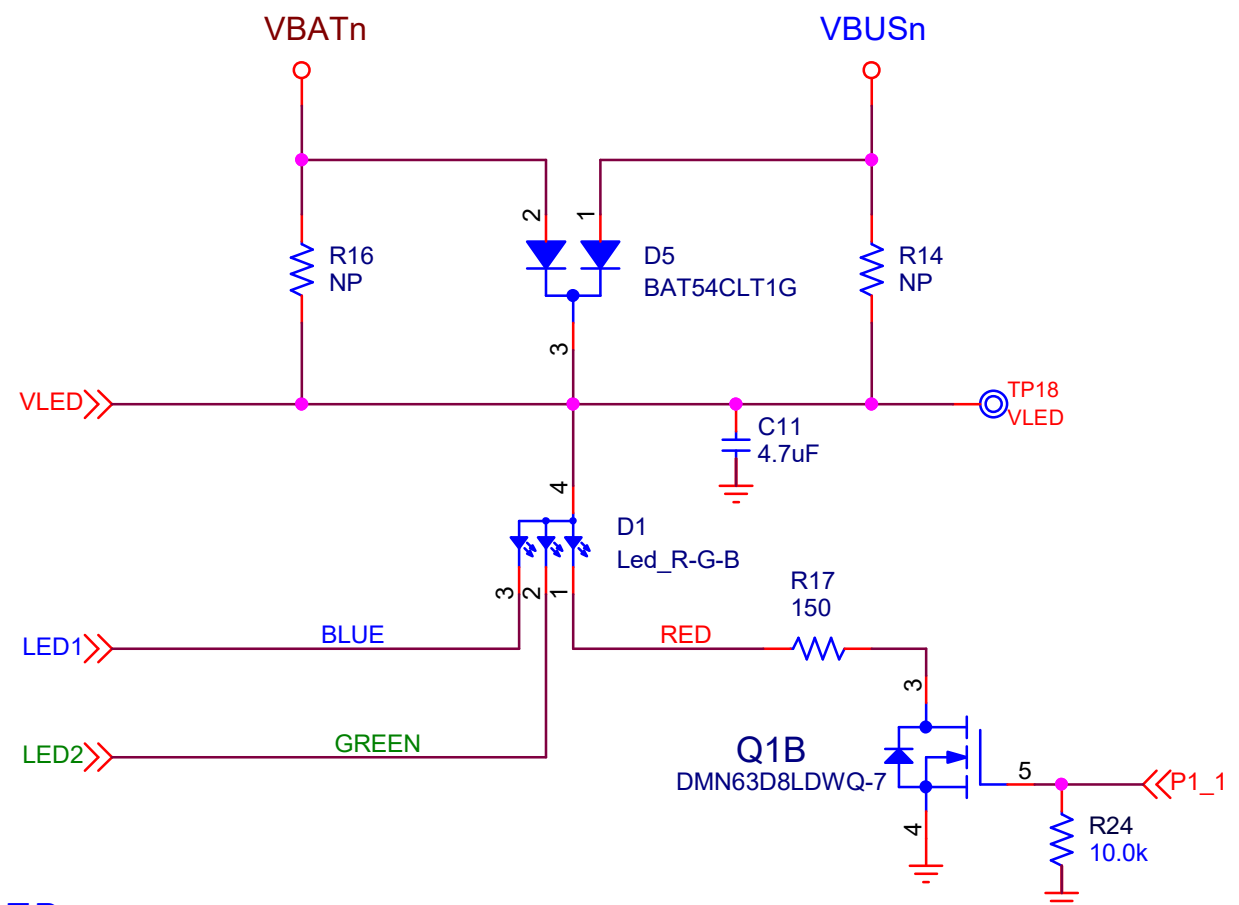

RGB LED

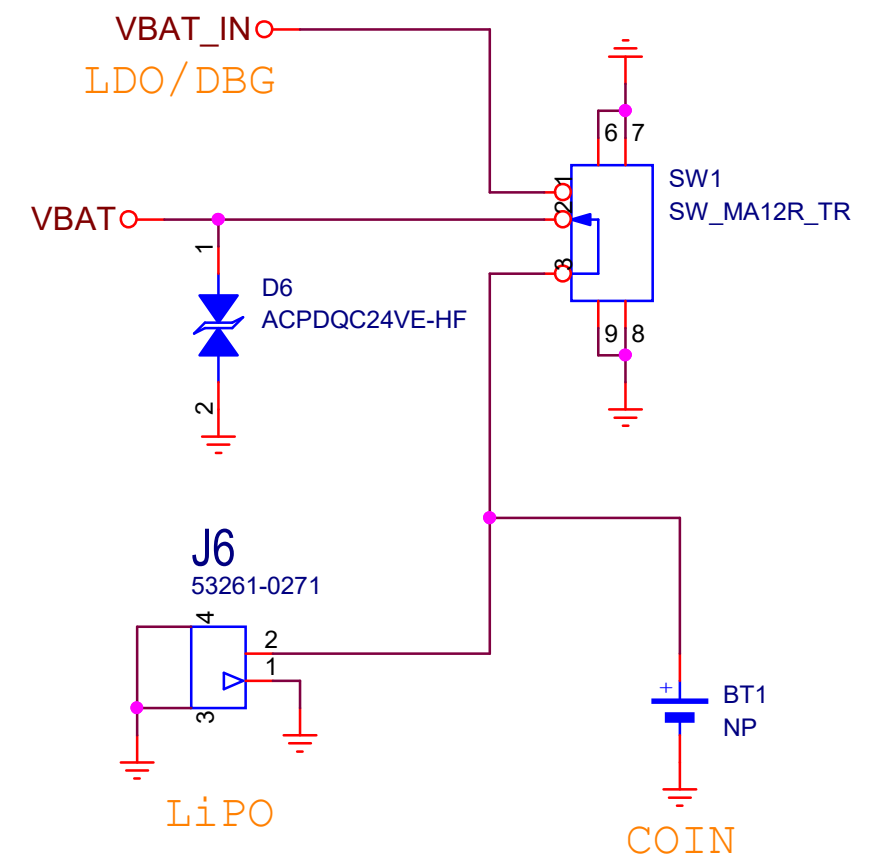

POWER OPTIONS

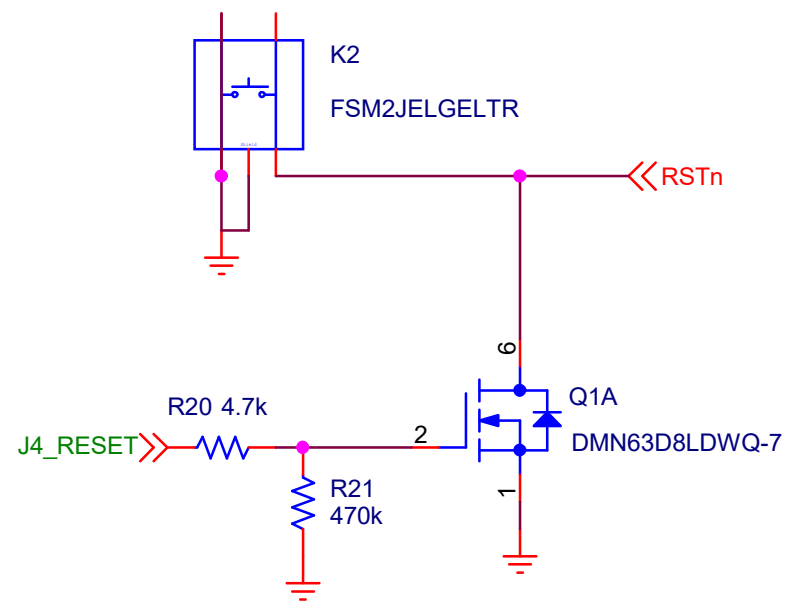

RESET BUTTON

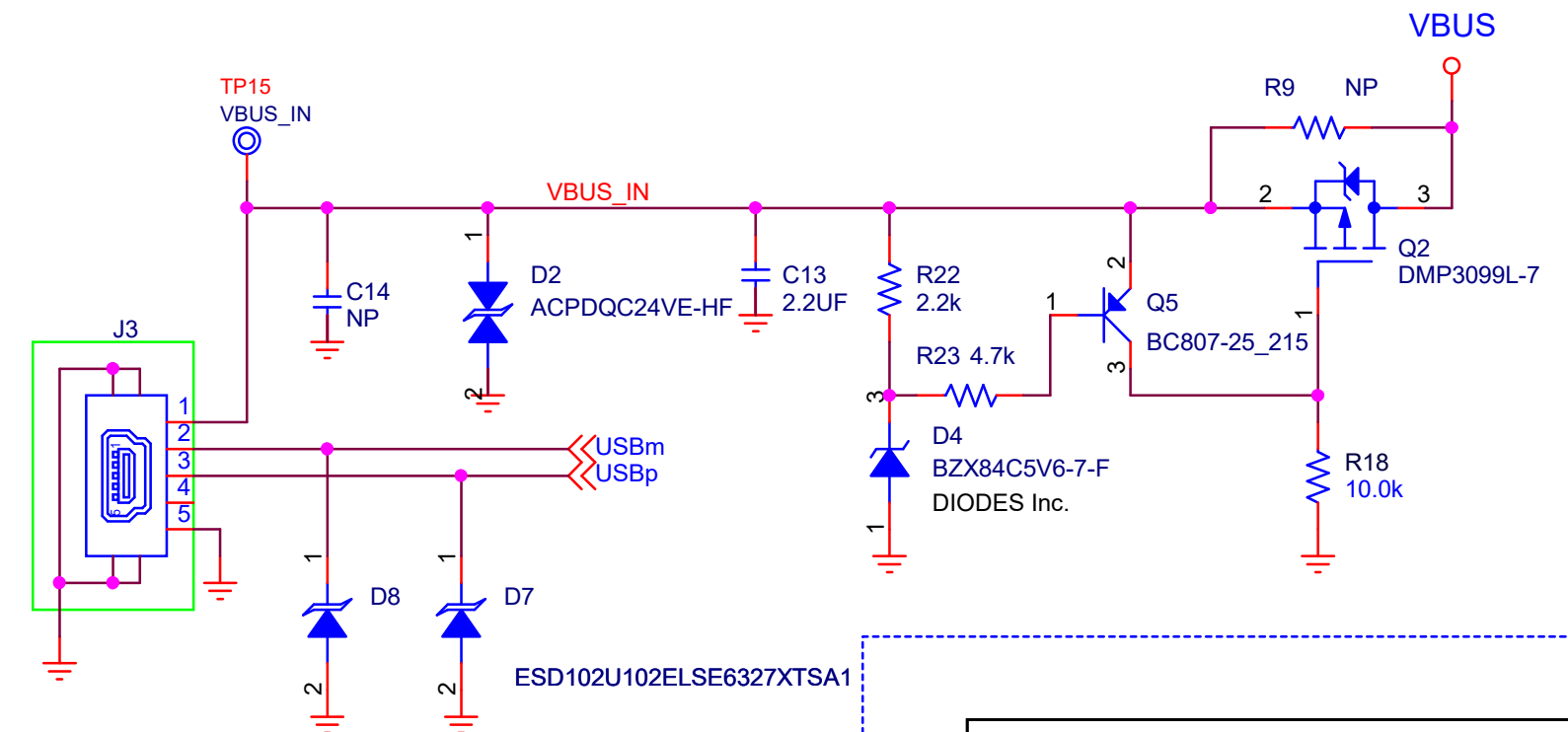

USB + OVP CIRCUIT

Dialog Semiconductor
N.E.O. Patron-Athinon 15
26441, Patras, Greece
tel. (+30) 2610390940
fax. (+30) 2610390941

Title : DA1469x devkt-pro daughterboard (VFBGA100)

Doc. Nr. 331-06-E	Designer: PR	Rev: E
Date: Tuesday, December 11, 2018	Sheet: 3 of 3	