

P8330

Single- or Dual-Input Multichannel SSD Power Management Solution

The P8330 is a multi-channel power management IC tailored for use in solid-state drive applications. It features multiple regulator outputs, inrush current control, and holdup power management functions.

The P8330 can be powered by single or dual 3.3V/5V and/or 5V/12V inputs, and provides a slew-rate limited turn-on for the external input switch. An I2C-compatible interface allows extensive programming and configuration of operating parameters. An internal multi-time programmable (MTP) memory allows permanent storage of configuration settings.

Simplified Block Diagram

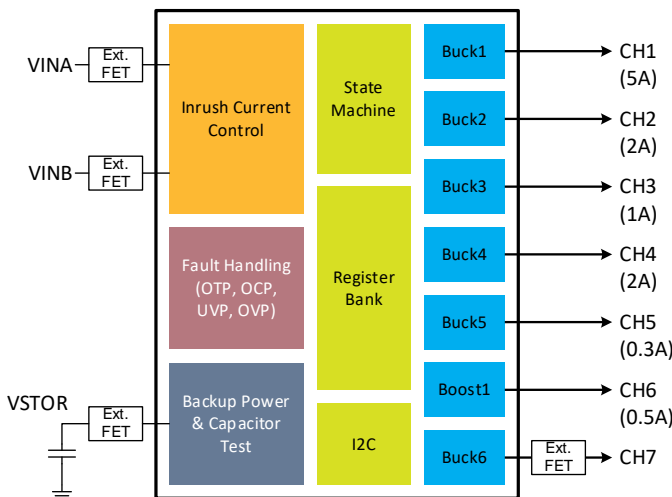

Typical Applications

- Solid-state drives
- Capacitor-based backup power sources

Features

- Input Voltage Range:
  - 2.75V to 5.75V on SRCA
  - 2.75V to 15V on SRCB
- Operation with Single- or Dual-Input Supplies
- Multiple Output Regulator Channels
  - Six step-down regulators with internal MOSFETs (Channels 1, 2, 3, 4, and 5)
  - One step-down regulator with internal drivers for external MOSFETs (Channel 7)
  - One step-up regulator with internal MOSFETs (Channel 6)
- Wide Output Voltage Range on Each Channel:
  - CH1: 0.55V to 1.825V
  - CH2 - CH5: 0.55V to 3.7375V
  - CH6: 11V to 14.1V
  - CH7: 0.55V to 3.7375V
- External Regulator Enable Control and Monitor
- Integrated Holdup Power Manager with Drivers for External MOSFETs
- Integrated Inrush Current Control
- Comprehensive Fault Protection
  - Input Overvoltage Protection
  - Input Undervoltage Lockout
  - Output Overvoltage Protection
  - Output Undervoltage Protection
  - Output Overcurrent Protection
  - Over-temperature Protection
- Soft-start and Soft-stop on All Output Rails
- Reset Output
- Power Fail Interrupt Output
- General Interrupt Output
- I2C-compatible Interface
- Extensive Programmability and Configuration Via Internal Registers
- Internal MTP Memory
- Package: 8 × 8 mm 68-Ild QFN

## IMPORTANT NOTICE AND DISCLAIMER

RENESAS ELECTRONICS CORPORATION AND ITS SUBSIDIARIES (“RENESAS”) PROVIDES TECHNICAL SPECIFICATIONS AND RELIABILITY DATA (INCLUDING DATASHEETS), DESIGN RESOURCES (INCLUDING REFERENCE DESIGNS), APPLICATION OR OTHER DESIGN ADVICE, WEB TOOLS, SAFETY INFORMATION, AND OTHER RESOURCES “AS IS” AND WITH ALL FAULTS, AND DISCLAIMS ALL WARRANTIES, EXPRESS OR IMPLIED, INCLUDING, WITHOUT LIMITATION, ANY IMPLIED WARRANTIES OF MERCHANTABILITY, FITNESS FOR A PARTICULAR PURPOSE, OR NON-INFRINGEMENT OF THIRD-PARTY INTELLECTUAL PROPERTY RIGHTS.

These resources are intended for developers who are designing with Renesas products. You are solely responsible for (1) selecting the appropriate products for your application, (2) designing, validating, and testing your application, and (3) ensuring your application meets applicable standards, and any other safety, security, or other requirements. These resources are subject to change without notice. Renesas grants you permission to use these resources only to develop an application that uses Renesas products. Other reproduction or use of these resources is strictly prohibited. No license is granted to any other Renesas intellectual property or to any third-party intellectual property. Renesas disclaims responsibility for, and you will fully indemnify Renesas and its representatives against, any claims, damages, costs, losses, or liabilities arising from your use of these resources. Renesas' products are provided only subject to Renesas' Terms and Conditions of Sale or other applicable terms agreed to in writing. No use of any Renesas resources expands or otherwise alters any applicable warranties or warranty disclaimers for these products.

(Disclaimer Rev.1.01 Jan 2024)

### Corporate Headquarters

TOYOSU FORESIA, 3-2-24 Toyosu,  
Koto-ku, Tokyo 135-0061, Japan  
[www.renesas.com](http://www.renesas.com)

### Trademarks

Renesas and the Renesas logo are trademarks of Renesas Electronics Corporation. All trademarks and registered trademarks are the property of their respective owners.

### Contact Information

For further information on a product, technology, the most up-to-date version of a document, or your nearest sales office, please visit [www.renesas.com/contact-us/](http://www.renesas.com/contact-us/).