

Introduction

The switching and routing of audio signals to meet the professional requirements of hi-fidelity equipment can be difficult to achieve. The ISL54405 offers a single supply, stereo 2:1 multiplexer for the switching and distribution of hi-fidelity audio. It has best in class THD+N performance and very high off-isolation for superior muting, to meet the demands of consumer and most professional applications. Its versatile architecture, negative swing capability, wide signal range, low r_{ON} , and unique click/pop elimination circuitry allows it to be used in DC or AC coupled ground referenced signal paths for use in both dual and single supply applications.

This technical brief describes the important key features of the ISL54405 listed below. It explains why the ISL54405 is a necessary component for both consumer and professional designers of audio equipment.

ISL54405 Key Features

1. ISL54405 Architecture
2. Single Supply Part with Negative Swing Capability and Wide Amplitude Range
3. Click and Pop Elimination Circuitry for AC and DC Coupled Applications
4. THD+N Performance (Best in Class)
5. High Off-Isolation for Superior Muting
6. Professional Audio Specifications

ISL54405 Architecture

Figure 1 shows a detailed block diagram of the ISL54405 architecture. The part consists of two single-pole/double-throw (SPDT) T-type in-line switches (shown in the blue boxes) configured as a differential 2:1 multiplexer, ancillary 40Ω shunts to ground on each of the signal lines (shown in the red boxes), and four logic control pins.

The SEL and MUTE logic pins control the main operation of the multiplexer. When MUTE is HIGH all channels of the SPDT switches are OFF. When MUTE is LOW then the logic level at the SEL pin will determine which differential channels are ON. If SEL = LOW; L1 / R1 are ON. If SEL = HIGH; L2/R2 are ON.

The AC/DC and DIR_SEL pins control whether the shunts are activated or not, and if active which side of the switch the shunt will be located on. An active shunt is only connected when the in-line switch it's connected to is OFF. The 40Ω shunts serve two primary functions:

1. In a single supply AC coupled application (see Figure 3) the shunt circuitry is activated and directed to the side of the switch connected to the audio drivers to eliminate click/pop noise in the speaker during power up and down of the audio CODEC drivers.
2. For superior muting when connected to a high impedance receiver input. The shunt circuitry is activated and directed to the side of the switch connected to the receiver. This gives >120dB of off-isolation when driving 10kΩ/20kΩ receiver loads.

The differential 2:1 multiplexer configuration allows two stereo sources to be multiplexed to a single speaker load or a single stereo source to be multiplexed to two different stereo speaker interfaces such as headphone jack or line-out port.

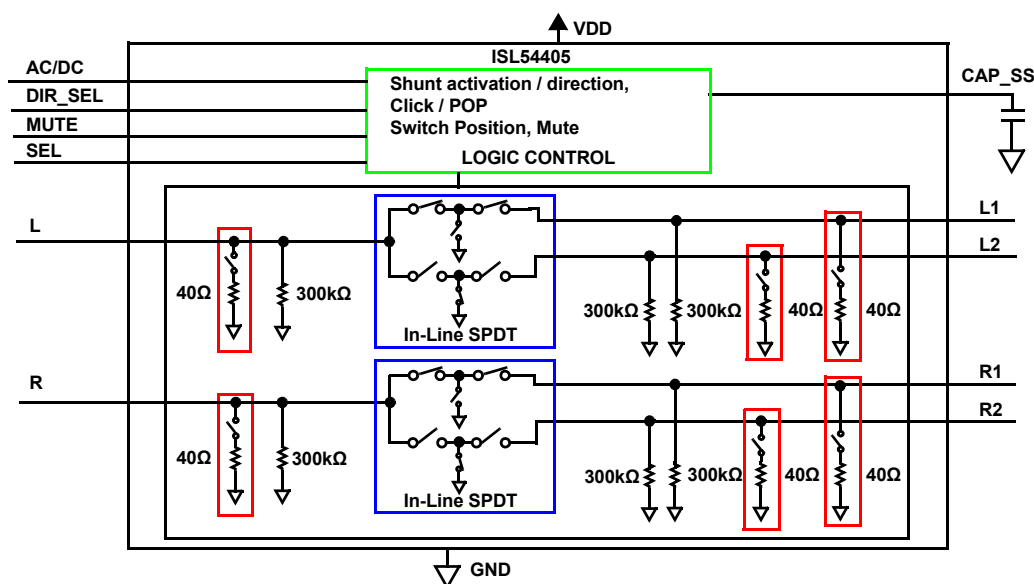

In-Line SPDT T-Type switches shown in the blue boxes (SPDT shown with L1/R1 ON (SEL = LOW, MUTE = LOW))
40Ω Shunts shown in the red boxes (Shunts in diagram are shown in the deactivated state (AC/DC = LOW)).

FIGURE 1. ISL54405 ARCHITECTURE

Wide Signal Range with Negative Swing Capability

The ISL54405 is a single supply part that can be powered from either a 3.3V or 5V DC power supply. It can pass both positive and negative signals with respect to ground without a negative supply rail. It was designed to pass signals in the range of -3V to +3V. This wide signal range and its 1.9Ω on-resistance allows it to be used with a wide range of audio loads; from 32Ω headphones to 20kΩ receiver loads.

Its negative swing capability allows it to be used in both single and dual supply applications.

One primary use for the ISL54405 is in an AC coupled single supply application as shown in Figure 3. Its ability to swing below ground allows it to be placed between the AC blocking capacitor and the speaker load. This placement allows one of the ISL54405 internal 40Ω shunts to be used to eliminate click and pop noise during power up and power down of the audio CODEC drivers (see the section titled "Click and POP Control for Single Supply AC Coupled Applications").

Figure 4 shows the ISL54405 being directly coupled to two dual supply audio drivers. Because it can pass a negative signal it can be directly connected to the drivers, eliminating the need for a DC blocking capacitor. In addition to multiplexing of the audio signals it has soft-start switching to eliminate click/pop noise in this type of application (See section titled "Click and POP Control for DC Coupled Applications").

Click and POP Operation

Click and POP Control for Single Supply AC Coupled Applications

Single supply audio drivers have their signal biased at a DC offset voltage of 1/2 the driver's DC supply voltage. A blocking capacitor must be put between the driver and speaker to remove this offset voltage from the speaker. Figure 2 shows this basic configuration. This circuit has a noise problem. During power up/down of the driver, a transient voltage will get coupled into the speaker, as the DC bias voltage rises or falls to its steady state value. This transient will cause an annoying click/pop sound in the speaker.

The ISL54405 can be used to eliminate the transient from getting to the speaker by placing it between the blocking cap and the speaker as shown in Figure 3. Note: The negative swing capability of the ISL54405 allows it to be placed after the blocking capacitor.

Before power up or power down of the audio driver, the ISL54405 shunt resistor on the blocking cap side of the switch is activated and the ISL54405 is put in the Mute state by taking the MUTE pin HIGH. After the DC bias voltage has reached its steady state and the transient has had sufficient time to be discharged through the shunt resistor, you can then turn the in-line switch of the ISL54405 ON to pass the audio signal to the speaker.

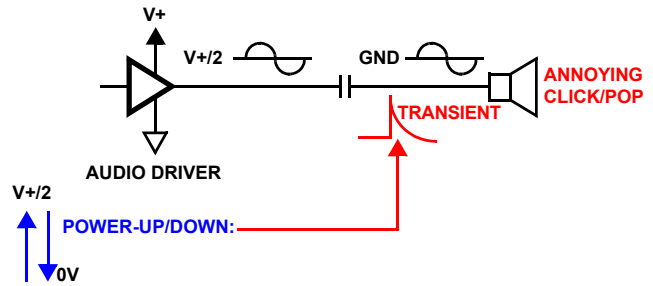

FIGURE 2. SINGLE SUPPLY AC COUPLED CONFIGURATION

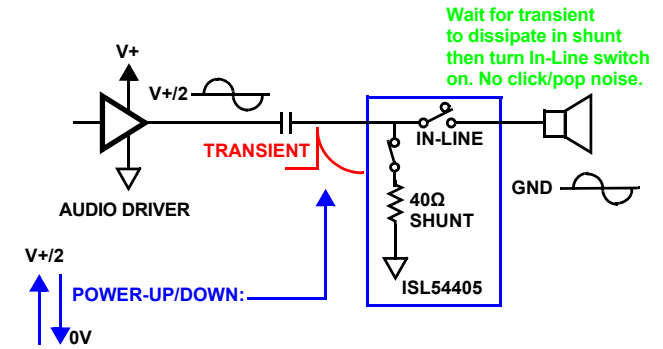

FIGURE 3. AC COUPLED CONFIGURATION WITH ISL54405 INSERTED

Click and POP Control for DC Coupled Applications

Figure 4 shows a dual supply application of two audio sources being multiplexed to a single speaker using the ISL54405 part (only one stereo channel is shown). Because of the negative swing capability of the ISL54405 it can be used in dual supply DC coupled applications and with its soft-start feature it will eliminate click/pop noise associated with the changing from one audio source to the other due to the different offset voltages of the drivers.

An ideal dual supply driver has its signal biased at ground. However, drivers are not ideal and tend to have an offset voltage in the range of ± a few millivolts to tens of millivolts. During switching between the audio channels or muting, these small DC driver offset levels can generate a transient that can cause an unwanted click/pop in the speaker.

The soft-start feature of the ISL54405 slowly ramps the amplitude of the output signal to the load which suppresses switching transients from being audible in the speaker. Lab experimentation has shown if you can slow the voltage ramp rate at the speaker to <10V/s, you can eliminate click/pop noise in a speaker.

The soft-start works by slowly decreasing the switch resistance from its high off resistance to its r_{ON} resistance of 1.9Ω when a switch cell is told to turned ON. This slow changing of the resistance slows the voltage ramping time at the load. The amplitude ramp time is set by the value of the soft-start capacitor. Figure 5 shows with a 0.1μF soft-start capacitor when going from the MUTE state to the ON state it took the output 13ms to get to 60mV. This equates to a 4.6V/s slew rate and this slow slewing does not cause click/pop noise in a speaker.

In a DC coupled application, the 40Ω shunts should not be used at the audio source side of the switch because they have no effect at eliminating transients and would consume unnecessary power.

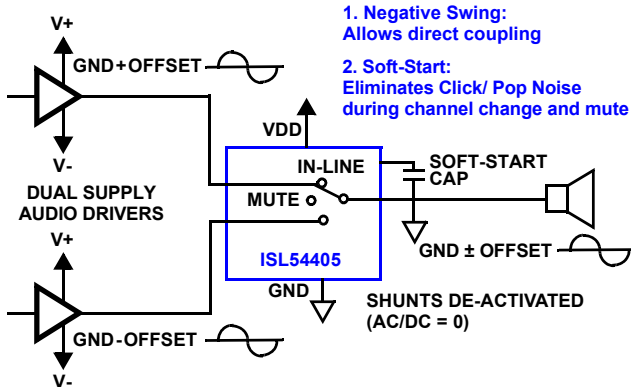

FIGURE 4. DUAL SUPPLY DC COUPLED CONFIGURATION

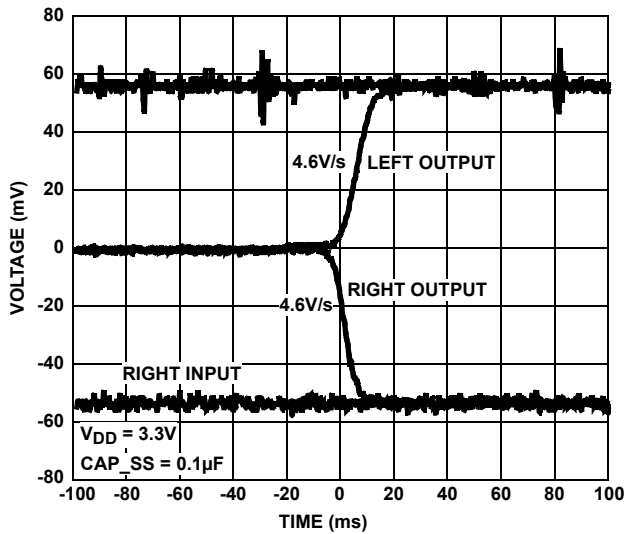

FIGURE 5. SOFT-START (0.1µF) CLICK/POP REDUCTION

THD+N Performance (Best in Class)

Figure 6 shows the typical bath-tub shaped r_{ON} curve for a standard CMOS switch. From the graph it is clear that the switch resistance changes as the signal voltage changes. This modulation of the resistance causes non-linear harmonic distortion to the signal passing through the switch. The greater the variation of r_{ON} over the signal range the greater the distortion. The less the r_{ON} of a switch varies the lower the Total Harmonic Distortion (THD) will be.

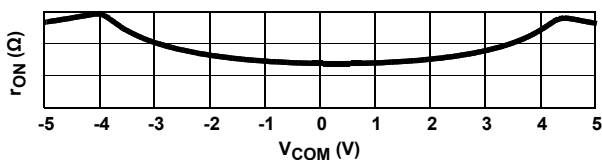

FIGURE 6. ON-RESISTANCE vs SWITCH SIGNAL VOLTAGE OF A STANDARD ANALOG SWITCH

Figure 7 below shows the r_{ON} curves for the ISL54405 at different temperatures. As you can see from these curves, the resistance changes very little as the signal level changes. Over the signal range of -2.828V to +2.828V the ISL54405 has an r_{ON} flatness of only 0.003Ω which results in ultra low distortion.

With a 1kHz, 2V_{RMS} signal driving a 20kΩ load, THD+N measures: -106dB (0.0006%). Lower the signal to 1.8V_{RMS}, THD+N measures: -116dB.

With a 1kHz, 0.707V_{RMS} signal driving a 32Ω load, THD+N measures: -100dB (0.001%). Lower the signal to 0.353V_{RMS}, THD+N measures: -108dB (0.0004%).

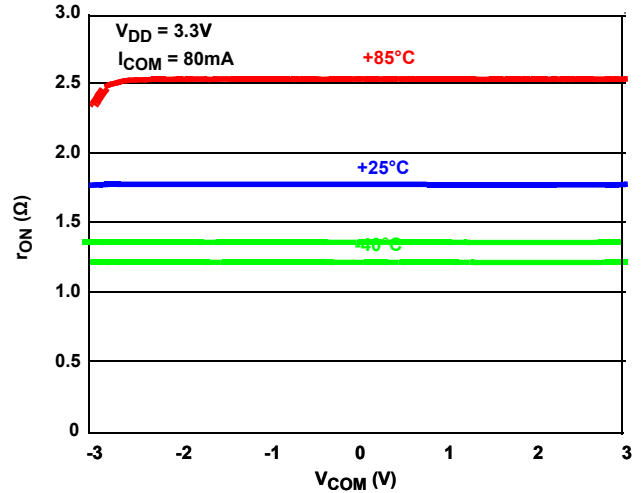

FIGURE 7. ON RESISTANCE vs SWITCH SIGNAL VOLTAGE vs TEMPERATURE

High Off-Isolation for Superior Muting

The high off-isolation of the ISL54405 is achieved by using a T-type architecture for the SPDT switch cells. Figure 8 shows the structure of a T-type SPDT switch. Splitting the in-line switch cell into two parts and putting a low impedance shunt to ground between them significantly improves the off-isolation of the ISL54405 versus that of a standard CMOS analog switch.

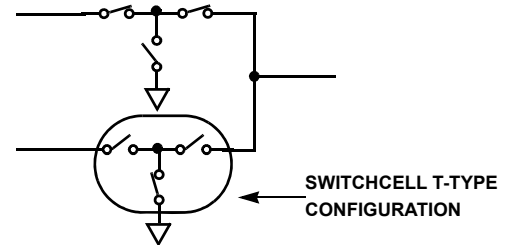

FIGURE 8. SPDT T-TYPE ARCHITECTURE

Figures 9 and 10 show off-isolation curves measured for the ISL54405 when connected to 32Ω and 20kΩ loads.

When driving a 32Ω load the off-isolation is > 120dB over the frequency range of 20Hz to 20kHz.

When driving a 20kΩ load the level of off-isolation over the audio frequency range depends on whether the 40Ω shunt is activated

on the load side of the switch or de-activated. The blue curve in Figure 10 shows that with the 40Ω shunt connected, the off-isolation is > 120dB and > -95dB without the shunt connected (red curve). For most applications when muting of high receiver loads you would configure the ISL54405 part to activate the shunt to get the > 120dB of off-isolation.

With > 120dB of off-isolation you can be sure the signal will not get through an off channel to the speaker.

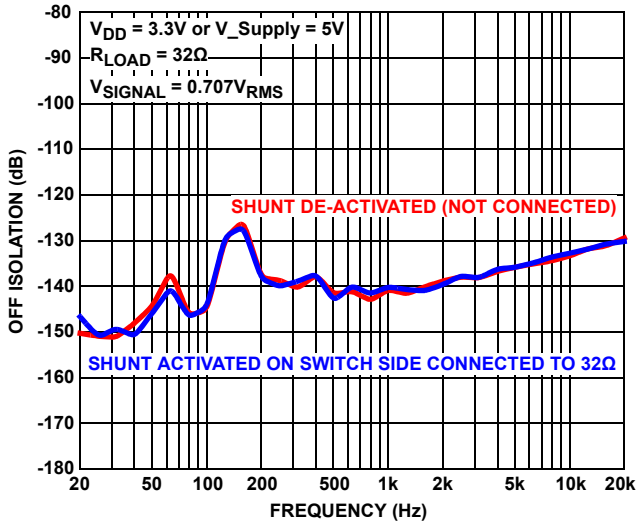

FIGURE 9. OFF ISOLATION, 0.707V_{RMS} SIGNAL, 32Ω LOAD

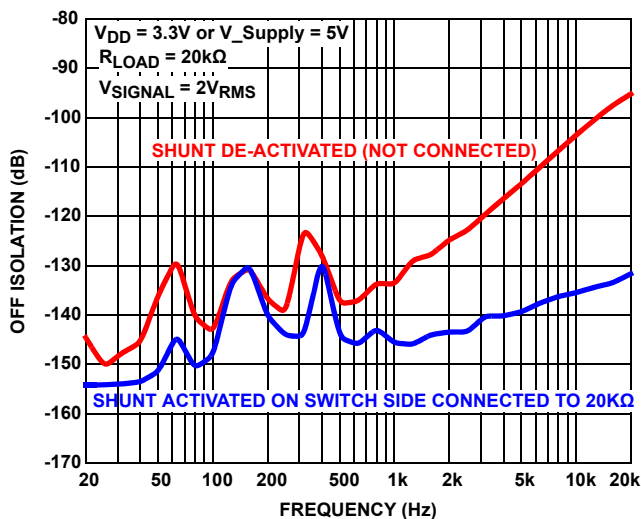

FIGURE 10. OFF ISOLATION, 2V_{RMS} SIGNAL, 20kΩ LOAD

Professional Grade Audio Specifications

The ISL54405 was designed to meet the exacting requirements of consumer and professional audio engineers. Table 1 provides values for key performance specifications.

TABLE 1. ISL54405 KEY PERFORMANCE SPECIFICATIONS

PARAMETER	TEST CONDITION	VALUE
THD+N	2V _{RMS} , 20kΩ Load, A-weighted Filter	0.0006% (-106dB)
	1V _{pp} (3.9mW), 32Ω load, A-weighted Filter	0.0004% (-108dB)
OFF Isolation	2V _{RMS} , 20kΩ Load, Shunt Active	>120dB
	0.7V _{RMS} , 32Ω Load	>120dB
SNR	20Hz to 20kHz (inputs grounded)	>124dB
Insertion Loss, G _{ON}	1kHz, 20kΩ Load	±0.01dB
Gain vs Freq, G _f	20Hz to 20kHz, 20kΩ Load, Reference to G _{ON} at 1kHz	±0.007dB
Cross-Talk (Channel to Channel)	2V _{RMS} , 20Hz to 20kHz, 20kΩ Load	120dB
PSRR	20kHz	90dB
	1kHz	110dB
Bandwidth, -3dB	R _{LOAD} = 50Ω	230MHz
Stereo Channel Imbalance L1 and R1, L2 and R2	20Hz to 20kHz, 20kΩ Load	±0.003dB

Conclusion

The ISL54405 offers a bidirectional audio switch/multiplexer that has click and pop control on the switching of the dual single-pole double-throw (SPDT) action. The switches can also handle both positive and negative signals without a negative supply rail. The state of the four input pins controls the switch positions, directions and muting status.

The dynamic characteristics are best in class: THD+N with a 2V_{RMS} signal with an A-weighted filter and 20kΩ load is a typical -106dB and SNR over the audio band of 20Hz to 20kHz (inputs grounded) is better than 124dBV. Insertion loss at 1kHz is ±0.01dB while the audio frequency response is within ±0.003dB. Muting is better than 120dB, similar to channel-to-channel crosstalk. PSRR is 90dB at 20kHz (110dB at 1kHz) and the -3dB bandwidth is a typical 230MHz. The supply used can be either 3.3V or 5.0V with worst current consumption at 65μA. The DC numbers are also great, but kind of irrelevant compared to the AC results.

The quality of this multiplexer is high enough for the most demanding professional applications although, of course, the majority will see their way into home theater, CD, DVD, Blu-ray, MP3, cellphone, and computer sound card type applications and they have been priced on that basis and packaged accordingly. The ISL54405 is in production in three packages: TQFN-16, uTQFN-16, and TSSOP-16.

Notice

1. Descriptions of circuits, software and other related information in this document are provided only to illustrate the operation of semiconductor products and application examples. You are fully responsible for the incorporation or any other use of the circuits, software, and information in the design of your product or system. Renesas Electronics disclaims any and all liability for any losses and damages incurred by you or third parties arising from the use of these circuits, software, or information.
2. Renesas Electronics hereby expressly disclaims any warranties against and liability for infringement or any other claims involving patents, copyrights, or other intellectual property rights of third parties, by or arising from the use of Renesas Electronics products or technical information described in this document, including but not limited to, the product data, drawings, charts, programs, algorithms, and application examples.
3. No license, express, implied or otherwise, is granted hereby under any patents, copyrights or other intellectual property rights of Renesas Electronics or others.
4. You shall not alter, modify, copy, or reverse engineer any Renesas Electronics product, whether in whole or in part. Renesas Electronics disclaims any and all liability for any losses or damages incurred by you or third parties arising from such alteration, modification, copying or reverse engineering.
5. Renesas Electronics products are classified according to the following two quality grades: "Standard" and "High Quality". The intended applications for each Renesas Electronics product depends on the product's quality grade, as indicated below.
"Standard": Computers; office equipment; communications equipment; test and measurement equipment; audio and visual equipment; home electronic appliances; machine tools; personal electronic equipment; industrial robots; etc.
"High Quality": Transportation equipment (automobiles, trains, ships, etc.); traffic control (traffic lights); large-scale communication equipment; key financial terminal systems; safety control equipment; etc.
Unless expressly designated as a high reliability product or a product for harsh environments in a Renesas Electronics data sheet or other Renesas Electronics document, Renesas Electronics products are not intended or authorized for use in products or systems that may pose a direct threat to human life or bodily injury (artificial life support devices or systems; surgical implantations; etc.), or may cause serious property damage (space system; undersea repeaters; nuclear power control systems; aircraft control systems; key plant systems; military equipment; etc.). Renesas Electronics disclaims any and all liability for any damages or losses incurred by you or any third parties arising from the use of any Renesas Electronics product that is inconsistent with any Renesas Electronics data sheet, user's manual or other Renesas Electronics document.
6. When using Renesas Electronics products, refer to the latest product information (data sheets, user's manuals, application notes, "General Notes for Handling and Using Semiconductor Devices" in the reliability handbook, etc.), and ensure that usage conditions are within the ranges specified by Renesas Electronics with respect to maximum ratings, operating power supply voltage range, heat dissipation characteristics, installation, etc. Renesas Electronics disclaims any and all liability for any malfunctions, failure or accident arising out of the use of Renesas Electronics products outside of such specified ranges.
7. Although Renesas Electronics endeavors to improve the quality and reliability of Renesas Electronics products, semiconductor products have specific characteristics, such as the occurrence of failure at a certain rate and malfunctions under certain use conditions. Unless designated as a high reliability product or a product for harsh environments in a Renesas Electronics data sheet or other Renesas Electronics document, Renesas Electronics products are not subject to radiation resistance design. You are responsible for implementing safety measures to guard against the possibility of bodily injury, injury or damage caused by fire, and/or danger to the public in the event of a failure or malfunction of Renesas Electronics products, such as safety design for hardware and software, including but not limited to redundancy, fire control and malfunction prevention, appropriate treatment for aging degradation or any other appropriate measures. Because the evaluation of microcomputer software alone is very difficult and impractical, you are responsible for evaluating the safety of the final products or systems manufactured by you.
8. Please contact a Renesas Electronics sales office for details as to environmental matters such as the environmental compatibility of each Renesas Electronics product. You are responsible for carefully and sufficiently investigating applicable laws and regulations that regulate the inclusion or use of controlled substances, including without limitation, the EU RoHS Directive, and using Renesas Electronics products in compliance with all these applicable laws and regulations. Renesas Electronics disclaims any and all liability for damages or losses occurring as a result of your noncompliance with applicable laws and regulations.
9. Renesas Electronics products and technologies shall not be used for or incorporated into any products or systems whose manufacture, use, or sale is prohibited under any applicable domestic or foreign laws or regulations. You shall comply with any applicable export control laws and regulations promulgated and administered by the governments of any countries asserting jurisdiction over the parties or transactions.
10. It is the responsibility of the buyer or distributor of Renesas Electronics products, or any other party who distributes, disposes of, or otherwise sells or transfers the product to a third party, to notify such third party in advance of the contents and conditions set forth in this document.
11. This document shall not be reprinted, reproduced or duplicated in any form, in whole or in part, without prior written consent of Renesas Electronics.
12. Please contact a Renesas Electronics sales office if you have any questions regarding the information contained in this document or Renesas Electronics products.
(Note 1) "Renesas Electronics" as used in this document means Renesas Electronics Corporation and also includes its directly or indirectly controlled subsidiaries.
(Note 2) "Renesas Electronics product(s)" means any product developed or manufactured by or for Renesas Electronics.

(Rev.4.0-1 November 2017)



SALES OFFICES

Renesas Electronics Corporation

<http://www.renesas.com>

Refer to "<http://www.renesas.com/>" for the latest and detailed information.

Renesas Electronics America Inc.
1001 Murphy Ranch Road, Milpitas, CA 95035, U.S.A.
Tel: +1-408-432-8888, Fax: +1-408-434-5351

Renesas Electronics Canada Limited
9251 Yonge Street, Suite 8309 Richmond Hill, Ontario Canada L4C 9T3
Tel: +1-905-237-2004

Renesas Electronics Europe Limited
Dukes Meadow, Millboard Road, Bourne End, Buckinghamshire, SL8 5FH, U.K
Tel: +44-1628-651-700, Fax: +44-1628-651-804

Renesas Electronics Europe GmbH
Arcadiastrasse 10, 40472 Düsseldorf, Germany
Tel: +49-211-6503-0, Fax: +49-211-6503-1327

Renesas Electronics (China) Co., Ltd.
Room 1709 Quantum Plaza, No.27 ZhichunLu, Haidian District, Beijing, 100191 P. R. China
Tel: +86-10-8235-1155, Fax: +86-10-8235-7679

Renesas Electronics (Shanghai) Co., Ltd.
Unit 301, Tower A, Central Towers, 555 Langao Road, Putuo District, Shanghai, 200333 P. R. China
Tel: +86-21-2226-0888, Fax: +86-21-2226-0999

Renesas Electronics Hong Kong Limited
Unit 1601-1611, 16/F., Tower 2, Grand Century Place, 193 Prince Edward Road West, Mongkok, Kowloon, Hong Kong
Tel: +852-2265-6688, Fax: +852-2886-9022

Renesas Electronics Taiwan Co., Ltd.
13F, No. 363, Fu Shing North Road, Taipei 10543, Taiwan
Tel: +886-2-8175-9600, Fax: +886-2-8175-9670

Renesas Electronics Singapore Pte. Ltd.
80 Bendemeer Road, Unit #06-02 Hyflux Innovation Centre, Singapore 339949
Tel: +65-6213-0200, Fax: +65-6213-0300

Renesas Electronics Malaysia Sdn.Bhd.
Unit 1207, Block B, Menara Amcorp, Amcorp Trade Centre, No. 18, Jln Persiaran Barat, 46050 Petaling Jaya, Selangor Darul Ehsan, Malaysia
Tel: +60-3-7955-9390, Fax: +60-3-7955-9510

Renesas Electronics India Pvt. Ltd.
No.777C, 100 Feet Road, HAL 2nd Stage, Indiranagar, Bangalore 560 038, India
Tel: +91-80-67208700, Fax: +91-80-67208777

Renesas Electronics Korea Co., Ltd.
17F, KAMCO Yangjae Tower, 262, Gangnam-daero, Gangnam-gu, Seoul, 06265 Korea
Tel: +82-2-558-3737, Fax: +82-2-558-5338