

The Principles of Current Sensing with Low-Voltage Precision Op-Amps

Current sensing is a vital process in electronic circuits, essential for monitoring and controlling the current flow. The utilization of low-voltage precision operational amplifiers (op-amps) in this realm is highly regarded due to their exceptional accuracy, minimal offset voltage, and stable performance across various temperatures and voltages. This document aims to elucidate the principles of current sensing using these op-amps, highlighting their functionalities and the considerations necessary for their effective implementation.

Contents

- 1. Current Sensing with Low Voltage Precision Op-Amps ..... 1
- 2. Using Low Voltage Precision Op-Amps ..... 2
- 3. Applications ..... 2
- 4. Revision History ..... 2

1. Current Sensing with Low Voltage Precision Op-Amps

The most common approach to current sensing involves the shunt resistor method. This technique entails the placement of a shunt resistor within the current’s pathway that requires monitoring. The fundamental principle here is based on Ohm’s Law, where the voltage drop across the resistor is directly proportional to the current flowing through it. However, this voltage drop is typically minuscule, necessitating amplification for accurate measurement.

Precision op-amps are employed precisely for this amplification. They are designed to amplify the voltage drop across the shunt resistor to a more substantial and measurable level, all while ensuring minimal interference with the current flow. These op-amps are adept at maintaining a high degree of accuracy in amplification, a critical factor in current sensing applications.

In addition to amplification, precision op-amps in current sensing circuits often incorporate a feedback mechanism. This feedback is crucial for controlling the gain of the op-amp, ensuring that the output voltage remains within the operational boundaries of the device, even with minor fluctuations in the shunt resistor’s voltage. This feedback mechanism is integral in maintaining the precision and accuracy of the current measurements.

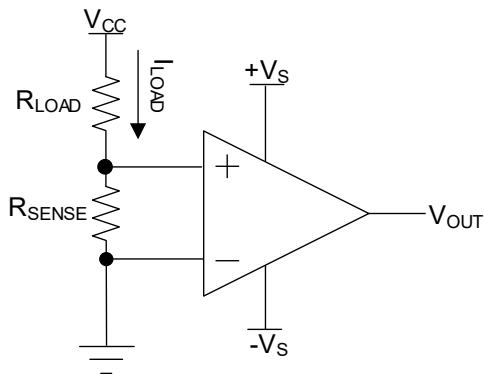

Figure 1. Low-Side Current Sensing

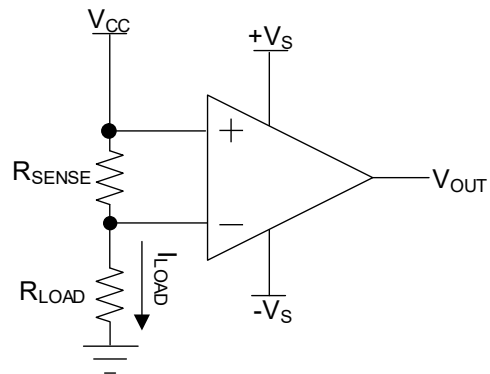

Figure 2. High-Side Current Sensing

## 2. Using Low Voltage Precision Op-Amps

Several key factors must be considered when implementing low-voltage precision op-amps in current sensing applications:

- **Low Offset Voltage** – These op-amps exhibit a very low offset voltage, which is imperative for achieving high accuracy in current measurements, particularly at lower current levels.
- **High Input Impedance** – The high input impedance of these op-amps is critical as it minimizes the loading effect on the circuit. This characteristic ensures that the current measurement process does not detrimentally impact the circuit performance.
- **Bandwidth and Speed** – The selected op-amp should possess an appropriate bandwidth and speed to respond swiftly to current changes, ensuring real-time monitoring and control.
- **Power Supply Requirements** – Given that these applications often involve low voltage operations, it is essential that the op-amp functions effectively at these lower power supply voltages.
- **Temperature Stability** – Precision op-amps are known for their temperature stability, a vital attribute for consistent performance across various environmental conditions.

## 3. Applications

These low-voltage precision op-amps find extensive applications in numerous domains. They are pivotal in battery management systems, where monitoring the charge and discharge currents is essential for optimizing battery life. In overcurrent protection, these op-amps are critical in detecting and responding to overcurrent situations in power supplies and motor controllers. Furthermore, they are increasingly being used in automotive systems, serving a crucial function in various vehicle sensors and control systems.

In summary, using low-voltage precision op-amps for current sensing is a highly effective method for attaining precise, reliable, and consistent current measurements in various electronic applications. The selection and configuration of the op-amp are contingent on the specific needs of the application, such as the current range to be measured, operating voltage, and required level of accuracy.

## 4. Revision History

Revision	Date	Description
1.00	Dec 12, 2023	Initial release.

## IMPORTANT NOTICE AND DISCLAIMER

RENESAS ELECTRONICS CORPORATION AND ITS SUBSIDIARIES (“RENESAS”) PROVIDES TECHNICAL SPECIFICATIONS AND RELIABILITY DATA (INCLUDING DATASHEETS), DESIGN RESOURCES (INCLUDING REFERENCE DESIGNS), APPLICATION OR OTHER DESIGN ADVICE, WEB TOOLS, SAFETY INFORMATION, AND OTHER RESOURCES “AS IS” AND WITH ALL FAULTS, AND DISCLAIMS ALL WARRANTIES, EXPRESS OR IMPLIED, INCLUDING, WITHOUT LIMITATION, ANY IMPLIED WARRANTIES OF MERCHANTABILITY, FITNESS FOR A PARTICULAR PURPOSE, OR NON-INFRINGEMENT OF THIRD PARTY INTELLECTUAL PROPERTY RIGHTS.

These resources are intended for developers skilled in the art designing with Renesas products. You are solely responsible for (1) selecting the appropriate products for your application, (2) designing, validating, and testing your application, and (3) ensuring your application meets applicable standards, and any other safety, security, or other requirements. These resources are subject to change without notice. Renesas grants you permission to use these resources only for development of an application that uses Renesas products. Other reproduction or use of these resources is strictly prohibited. No license is granted to any other Renesas intellectual property or to any third party intellectual property. Renesas disclaims responsibility for, and you will fully indemnify Renesas and its representatives against, any claims, damages, costs, losses, or liabilities arising out of your use of these resources. Renesas' products are provided only subject to Renesas' Terms and Conditions of Sale or other applicable terms agreed to in writing. No use of any Renesas resources expands or otherwise alters any applicable warranties or warranty disclaimers for these products.

(Disclaimer Rev.1.0 Mar 2020)

### Corporate Headquarters

TOYOSU FORESIA, 3-2-24 Toyosu,  
Koto-ku, Tokyo 135-0061, Japan  
[www.renesas.com](http://www.renesas.com)

### Contact Information

For further information on a product, technology, the most up-to-date version of a document, or your nearest sales office, please visit:  
[www.renesas.com/contact/](http://www.renesas.com/contact/)

### Trademarks

Renesas and the Renesas logo are trademarks of Renesas Electronics Corporation. All trademarks and registered trademarks are the property of their respective owners.