

Description

The MK1716-01 is a versatile serial programmable clock source which takes up very little board space.

The device can simultaneously generate two groups of 4 output clocks and a reference clock output. Both clock groups (CLKA and CLKB) are derived from a single PLL, and have the ability to incorporate Spread Spectrum frequency modulation for reduced system EMI. Each group has control of independent PLL output divide values. Outputs may be programmed on the fly, and will lock to a new frequency in 10 ms or less.

Each of the two groups are powered by a separate VDDIO voltage. The reference clock uses the fixed VDD voltage. VDDIO may vary from 2.5 V to VDD.

The devices includes a OE pin which tri-states the output clocks and when tied low.

IDT's VersaClock™ software allows the user to generate MK1716-01 device optimizing configuration code for target output frequencies and spread spectrum amounts.

Block Diagram

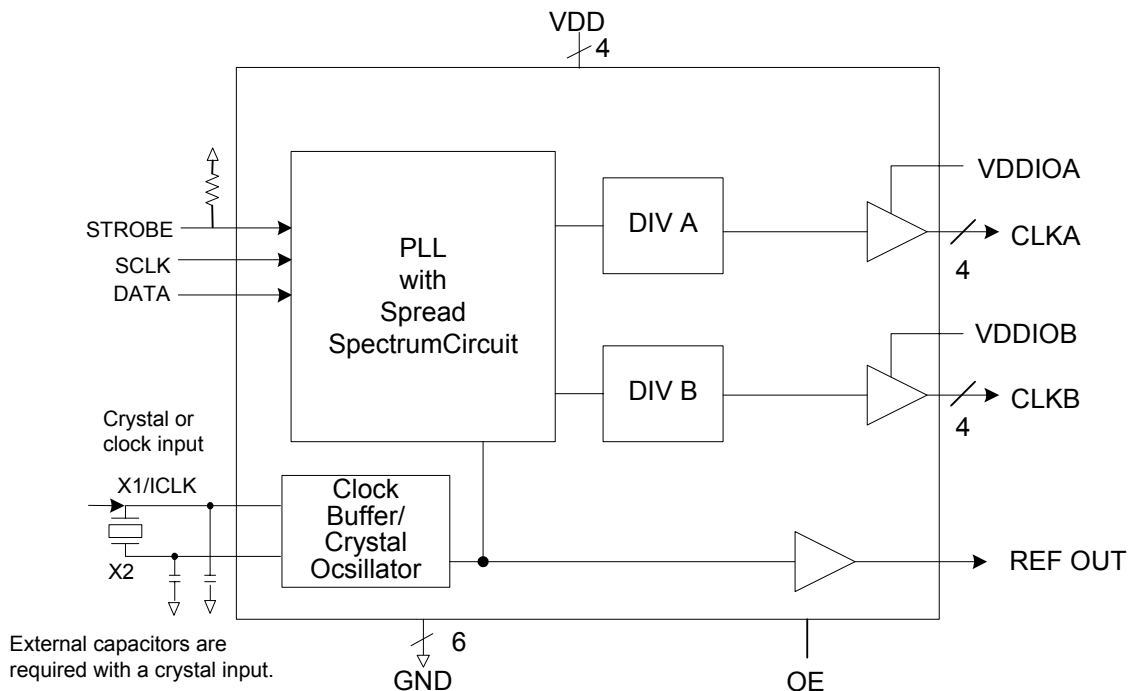

Features

- Packaged in 28-pin SSOP
- Operating voltage 3.3 V
- Serially programmable: user determines the output frequency via a 3-wire interface
- Highly accurate frequency generation
- M/N Multiplier PLL: M = 1..2048, N = 1..1024
- Eliminates the need for custom Quartz Oscillators
- Input crystal frequency of 5-27 MHz
- Input clock frequency of 3-50 MHz
- Output clock frequencies of 250 kHz to 133.33 MHz
- Spread Spectrum frequency modulation for reduced system EMI
- Center or down spread $\pm 0.5\%$ min to 4% total
- Selectable 32 kHz and 120 kHz modulation rate
- Advanced, low power, sub-micron CMOS process
- Separate VDD 's for each bank of 4 outputs
- Output skew <250 ps within output bank
- OE control on outputs

Pin Assignment

DATA	<input type="checkbox"/>	1	28	<input type="checkbox"/>	GND
X2	<input type="checkbox"/>	2	27	<input type="checkbox"/>	STROBE
X1/ICLK	<input type="checkbox"/>	3	26	<input type="checkbox"/>	SCLK
REFOUT	<input type="checkbox"/>	4	25	<input type="checkbox"/>	OE
VDD	<input type="checkbox"/>	5	24	<input type="checkbox"/>	VDD
VDD	<input type="checkbox"/>	6	23	<input type="checkbox"/>	VDD
GND	<input type="checkbox"/>	7	22	<input type="checkbox"/>	VDD
GND	<input type="checkbox"/>	8	21	<input type="checkbox"/>	GND
GND	<input type="checkbox"/>	9	20	<input type="checkbox"/>	GND
CLKA	<input type="checkbox"/>	10	19	<input type="checkbox"/>	CLKB
CLKA	<input type="checkbox"/>	11	18	<input type="checkbox"/>	CLKB
CLKA	<input type="checkbox"/>	12	17	<input type="checkbox"/>	CLKB
CLKA	<input type="checkbox"/>	13	16	<input type="checkbox"/>	CLKB
VDDIOA	<input type="checkbox"/>	14	15	<input type="checkbox"/>	VDDIOB

Note:

Clock A and Clock B can be at the same frequency or not, but must be powered by separate VDDs.

Pin Descriptions

Pin Number	Pin Name	Pin Type	Pin Description
1	DATA	Input	Serial shift register data input.
2	X2	XO	Connect to crystal. Leave open for clock input.
3	X1/ICLK	XI	Connect this pin to a crystal or external clock input.
4	REFOUT	Output	Reference clock output.
5-6	VDD	P	Connect to +3.3 V.
7-9	GND	P	Connect to ground.
10-13	CLKA	Output	Output clock.
14	VDDIOA	P	Power supply to CLKA.
15	VDDIOB	P	Power supply to CLKB.
16-19	CLKB	Output	Output clock.
20-21	GND	P	Connect to ground.
22-24	VDD	P	Connect to +3.3 V.
25	OE	Input	Output enable active high.
26	SRCLK	Input	Serial shift register clock.
27	STROBE	Input	Strobe to load data. See timing diagram. Use external 250 kOhm pull-up.
28	GND	Input	Connect to ground.

Configuring the MK1716-01

Initial State: The MK1716-01 may be configured to have up to nine frequency outputs, utilizing a single PLL and on-board spread spectrum circuitry. Unprogrammed, the part has the following outputs, related to the reference input clock:

Default Outputs	
Output	Frequency
Clock 1-9 (Pins 4, 10 - 19)	Reference output

The STROBE pin must have an external 250 kOhm pull-up resistor to achieve the Initial State.

The input crystal range for the MK1716-01 is 5 MHz to 27 MHz.

The MK1716-01 can be programmed to set the output functions and frequencies. 160 data bits generated by the VersaClock™ software are written in DATA pin in this order: MSB (left most bit) first.

As show in Figure 2, after these 160 bits are clocked into the MK1716-01, taking STROBE high will send this data to the internal latch and the CLK output will lock within 10 ms.

Note: STROBE utilizes a transparent latch that is latched when in the high state. If STROBE is in the high state and SCLK is pulsed, DATA is clocked directly to the internal latch and the output conditions will change accordingly. Although this will not damage the MK1716-01, it is recommended that STROBE be kept low while DATA is being clocked into the MK1716-01 in order to avoid unintended changes on the output clocks.

AC Parameters for Writing to the MK1716-01

Parameter	Condition	Min.	Max.	Units
t_{SETUP}	Setup time	10		ns
t_{HOLD}	Hold time after SCLK	10		ns
t_{W}	Data wait time	10		ns
t_{S}	Strobe pulse width	40		ns
	SCLK Frequency		30	MHz

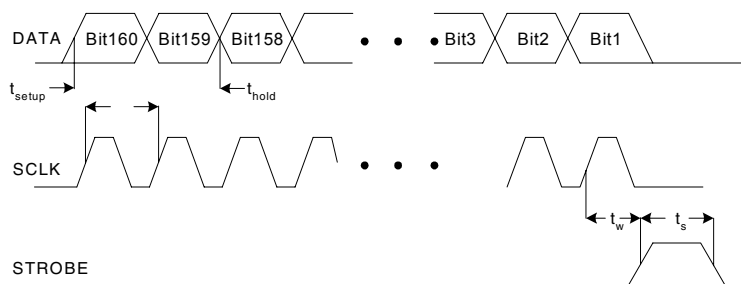

Figure 2. Timing Diagram for Programming the MK1716-01

External Components

Series Termination Resistor

Clock output traces over one inch should use series termination. To series terminate a 50Ω trace (a commonly used trace impedance), place a 33Ω resistor in series with the clock line, as close to the clock output pin as possible. The nominal impedance of the clock output is 20Ω.

STROBE Pull-up Resistor

In order for the device to start up in the default state, a 250 kΩ pull-up resistor is required.

Decoupling Capacitors

As with any high-performance mixed-signal IC, the MK1716-01 must be isolated from system power supply noise to perform optimally.

Decoupling capacitors of 0.01μF must be connected between each VDD and the PCB ground plane.

Crystal Load Capacitors

The device crystal connections should include pads for small capacitors from X1 to ground and from X2 to ground. These capacitors are used to adjust the stray capacitance of the board to match the nominally required crystal load capacitance. Because load capacitance can only be increased in this trimming process, it is important to keep stray capacitance to a minimum by using very short PCB traces (and no vias) between the crystal and device. Crystal capacitors must be connected from each of the pins X1 and X2 to ground.

The value (in pF) of these crystal caps should equal $(C_L - 6 \text{ pF})^2$. In this equation, C_L = crystal load capacitance in pF. Example: For a crystal with a 16 pF load capacitance, each crystal capacitor would be 20 pF $[(16-6) \times 2] = 20$.

PCB Layout Recommendations

For optimum device performance and lowest output phase noise, the following guidelines should be observed.

1) Each 0.01μF decoupling capacitor should be mounted on the component side of the board as close to the VDD pin as possible. No vias should be used between decoupling capacitor and VDD pin. The PCB trace to VDD pin should be kept as short as possible, as should the PCB trace to the ground via.

2) The external crystal should be mounted just next to the device with short traces. The X1 and X2 traces should not be routed next to each other with minimum spaces, instead they should be separated and away from other traces.

3) To minimize EMI, the 33Ω series termination resistor (if needed) should be placed close to each clock output.

4) An optimum layout is one with all components on the same side of the board, minimizing vias through other signal layers.

MK1716-01 Configuration Capabilities

The architecture of the MK1716-01 allows the user to easily configure the device to a wide range of output frequencies, for a given input reference frequency.

The frequency multiplier PLL provides a high degree of precision. The M/N values (the multiplier/divide values available to generate the target VCO frequency) can be set within the range of $M = 1$ to 2048 and $N = 1$ to 1024.

The MK1716-01 also provides separate output divide values, from 2 through 20, to allow the two output clock banks to support widely differing frequency values from the same PLL.

Each output frequency can be represented as:

$$\text{Output Freq.} = (\text{Ref. Freq.}) \times (M/N) / \text{Output Divide}$$

Each output clock bank has an separate voltage drive control pin (VDDIOA and VDDIOB) that sets the output clock voltage swing.

IDT VersaClock Software

IDT applies years of PLL optimization experience into a user friendly software that accepts the user's target reference clock and output frequencies and generates the lowest jitter, lowest power configuration, with only a press of a button. The user does not need to have prior PLL experience or determine the optimal VCO frequency to support multiple output frequencies.

VersaClock software quickly evaluates accessible VCO frequencies with available output divide values and provides an easy to understand, bar code rating for the target output

frequencies. The user may evaluate output accuracy, performance trade-off scenarios in seconds.

Spread Spectrum Modulation

The MK1716-01 utilizes frequency modulation (FM) to distribute energy over a range of frequencies. By modulating the output clock frequencies, the device effectively lowers energy across a broader range of frequencies; thus, lowering a system's electro-magnetic interference (EMI). The modulation rate is the time from transitioning from a minimum frequency to a maximum frequency and then back to the minimum.

Spread Spectrum Modulation can be applied as either "center spread" or "down spread". During center spread modulation, the deviation from the target frequency is equal in the positive and negative directions. The effective average frequency is equal to the target frequency. In applications where the clock is driving a component with a maximum frequency rating, down spread should be applied. In this case, the maximum frequency, including modulation,

is the target frequency. The effective average frequency is less than the target frequency.

The MK1716-01 operates in both center spread and down spread modes. For center spread, the frequency can be modulated between $\pm 0.125\%$ to $\pm 2.0\%$. For down spread, the frequency can be modulated between -0.25% to -4.0% .

Both output frequency banks will utilize identical spread spectrum percentage deviations and modulation rates, if a common VCO frequency can be identified.

Spread Spectrum Modulation Rate

The spread spectrum modulation frequency applied to the output clock frequency may occur at a variety of rates. For applications requiring the driving of "down-circuit" PLLs, Zero Delay Buffers, or those adhering to PCI standards, the spread spectrum modulation rate should be set to 30-33 kHz. For other applications, a 120 kHz modulation option is available.

Absolute Maximum Ratings

Stresses above the ratings listed below can cause permanent damage to the MK1716-01. These ratings, which are standard values for IDT commercially rated parts, are stress ratings only. Functional operation of the device at these or any other conditions above those indicated in the operational sections of the specifications is not implied. Exposure to absolute maximum rating conditions for extended periods can affect product reliability. Electrical parameters are guaranteed only over the recommended operating temperature range.

Parameter	Condition	Min.	Typ.	Max.	Units
Supply Voltage, VDD	Referenced to GND			7	V
Inputs	Referenced to GND	-0.5		VDD + 0.5	V
Clock Outputs	Referenced to GND	-0.5		VDD + 0.5	V
Storage Temperature		-65		150	°C
Soldering Temperature	Max 10 seconds			260	°C

Recommended Operation Conditions

Parameter	Min.	Typ.	Max.	Units
Ambient Operating Temperature	0		+70	°C
Power Supply Voltage (measured in respect to GND)	+3.0		+3.6	V
Power Supply Ramp Time			4	ms

DC Electrical Characteristics

VDD=3.3 V ±10% Ambient temperature 0 to +70°C, unless stated otherwise

Parameter	Symbol	Conditions	Min.	Typ.	Max.	Units
Operating Voltage	VDD		3.00		3.60	V
Operating Supply Current Input High Voltage	IDD	Configuration Dependent See VersaClock™				mA
		Ex. 14.31818 MHz crystal, VDD=VDDIO=3.3V, OE = 0		55		mA
				15		mA
VDDIO Voltage		VDDIOA and VDDIOB	2.25		VDD	V
Input High Voltage	V _{IH}	ICLK only	(VDD/2)+1			V
Input Low Voltage	V _{IL}	ICLK only			(VDD/2)-1	V
Input High Voltage	V _{IH}		VDD-0.5			V
Input Low Voltage	V _{IL}	OE, SCLK, DATA, STROBE			0.8	V
Output High Voltage	V _{OH}	I _{OH} = -8 mA	2.4			V
Output Low Voltage	V _{OL}	I _{OL} = 8 mA			0.4	V
Output High Voltage, CMOS level	V _{OH}	I _{OH} = -4 mA	VDD-0.4			V
Short Circuit Current		CLK outputs		±70		mA
Nominal Output Impedance	Z _{OUT}			20		Ω
Input Capacitance	C _{IN}	OE pin		4		pF
Internal Pull-down Resistor	R _{PD}	CLK outputs		510		kΩ
Internal Pull-up Resistor	R _{PU}	OE pin		240		kΩ

AC Electrical Characteristics

VDD = 3.3 V ±10%, Ambient Temperature 0 to +70° C, unless stated otherwise

Parameter	Symbol	Conditions	Min.	Typ.	Max.	Units
Input Frequency	F _{IN}	Fundamental crystal	5		27	MHz
		Input clock	2		50	MHz
Output Frequency		VDD=3.3 V	0.25		133.33	MHz
Output Clock Rise Time	t _{OR}	20% to 80%, Note 1		0.8		ns
Output Clock Fall Time	t _{OF}	80% to 20%, Note 1		0.8		ns
Output Clock Duty Cycle		Note 2	40	49-51	60	%
Power-up Time		STROBE goes high until stable CLK out		3	10	ms
		OE goes high until stable CLK out, PLL already running			50	ns
Maximum Output Jitter, short term	t _j	Reference clock, Note 1		±300		ps
Maximum Output Jitter, short term	t _j	All other clocks, Note 1 configuration dependent		±200		ps
Skew on the same bank		Same voltage and frequency		150		ps
Skew bank to bank		Same voltage and frequency		150		ps
Spread Spectrum Modulation Amount		Center or down spread	0.5		4.0	%

Note 1: Measured with 15 pF load.

Note 2: Duty Cycle is configuration dependent. Most configurations are min 45% / max 55%

Thermal Characteristics

Parameter	Symbol	Conditions	Min.	Typ.	Max.	Units
Thermal Resistance Junction to Ambient	θ _{JA}	Still air		135		°C/W
	θ _{JA}	1 m/s air flow		93		°C/W
	θ _{JA}	3 m/s air flow		78		°C/W
Thermal Resistance Junction to Case	θ _{JC}			60		°C/W

Package Outline and Package Dimensions (28-pin SSOP, 150 Mil. Wide Body)

Package dimensions are kept current with JEDEC Publication No. 95

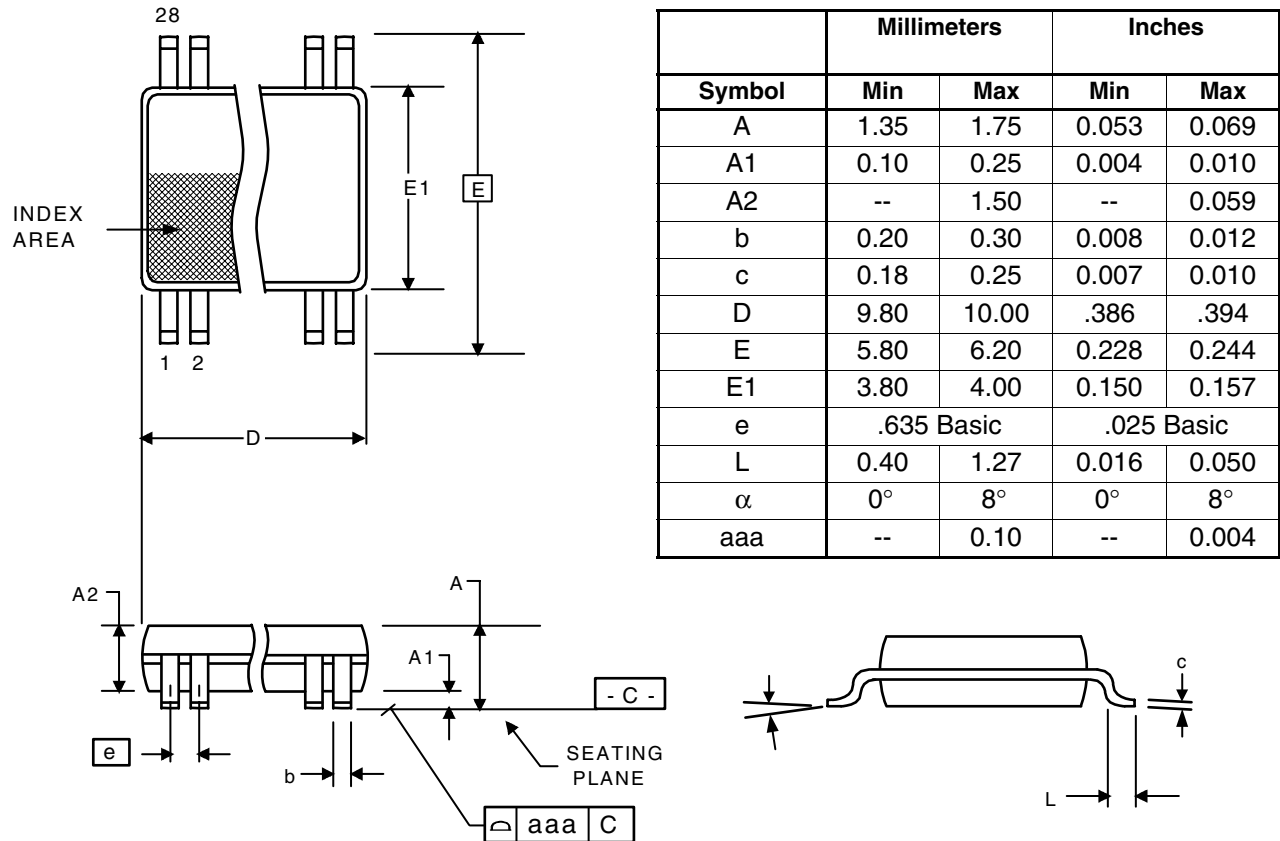

Ordering Information

Part / Order Number	Marking	Shipping Packaging	Package	Temperature
MK1716-01RLF		Tubes	28-pin SSOP	0 to +70° C
MK1716-01RLFT		Tape and Reel	28-pin SSOP	0 to +70° C

While the information presented herein has been checked for both accuracy and reliability, Integrated Device Technology (IDT) assumes no responsibility for either its use or for the infringement of any patents or other rights of third parties, which would result from its use. No other circuits, patents, or licenses are implied. This product is intended for use in normal commercial applications. Any other applications such as those requiring extended temperature range, high reliability, or other extraordinary environmental requirements are not recommended without additional processing by IDT. IDT reserves the right to change any circuitry or specifications without notice. IDT does not authorize or warrant any IDT product for use in life support devices or critical medical instruments.

IMPORTANT NOTICE AND DISCLAIMER

RENESAS ELECTRONICS CORPORATION AND ITS SUBSIDIARIES (“RENESAS”) PROVIDES TECHNICAL SPECIFICATIONS AND RELIABILITY DATA (INCLUDING DATASHEETS), DESIGN RESOURCES (INCLUDING REFERENCE DESIGNS), APPLICATION OR OTHER DESIGN ADVICE, WEB TOOLS, SAFETY INFORMATION, AND OTHER RESOURCES “AS IS” AND WITH ALL FAULTS, AND DISCLAIMS ALL WARRANTIES, EXPRESS OR IMPLIED, INCLUDING, WITHOUT LIMITATION, ANY IMPLIED WARRANTIES OF MERCHANTABILITY, FITNESS FOR A PARTICULAR PURPOSE, OR NON-INFRINGEMENT OF THIRD-PARTY INTELLECTUAL PROPERTY RIGHTS.

These resources are intended for developers who are designing with Renesas products. You are solely responsible for (1) selecting the appropriate products for your application, (2) designing, validating, and testing your application, and (3) ensuring your application meets applicable standards, and any other safety, security, or other requirements. These resources are subject to change without notice. Renesas grants you permission to use these resources only to develop an application that uses Renesas products. Other reproduction or use of these resources is strictly prohibited. No license is granted to any other Renesas intellectual property or to any third-party intellectual property. Renesas disclaims responsibility for, and you will fully indemnify Renesas and its representatives against, any claims, damages, costs, losses, or liabilities arising from your use of these resources. Renesas' products are provided only subject to Renesas' Terms and Conditions of Sale or other applicable terms agreed to in writing. No use of any Renesas resources expands or otherwise alters any applicable warranties or warranty disclaimers for these products.

(Disclaimer Rev.1.01 Jan 2024)

Corporate Headquarters

TOYOSU FORESIA, 3-2-24 Toyosu,
Koto-ku, Tokyo 135-0061, Japan
www.renesas.com

Trademarks

Renesas and the Renesas logo are trademarks of Renesas Electronics Corporation. All trademarks and registered trademarks are the property of their respective owners.

Contact Information

For further information on a product, technology, the most up-to-date version of a document, or your nearest sales office, please visit www.renesas.com/contact-us/.