

## Introduction

The Intel family of microprocessors continues to increase in size with the addition of its next generation microprocessors. These newer processors are the most advanced pieces of silicon Intel has developed, requiring advanced power management solutions that have strict requirements for core voltage, transient response, and peak current demands. Responding to the increasing needs of these new Intel processors, Intersil introduces the ISL6565B and ISL6605 chipset to enable the next generation of power management solutions.

## Intersil ISL6565B and ISL6605

The ISL6565B controller IC and three ISL6605 Driver ICs work together to create a versatile three-phase power management solution. The ISL6565B is tailored specifically to accommodate Intel's next generation microprocessor specifications, while the ISL6605 is a high efficient single-phase driver, capable of handling the stresses of high current loads. The ISL6565BEVAL1 combines these four ICs to form a highly integrated solution for Intel's high current, high slew-rate applications.

The ISL6565B regulates core voltage, balances the phase currents, and provides protective features for two or three synchronous buck converter channels. The controller uses a 6-bit DAC, giving the user a digital interface to select the output voltage, which is precisely regulated to  $\pm 0.5\%$  accuracy using differential remote voltage sensing. The ISL6565B also has DCR current sensing to balance the channel currents and give the user control of the output voltage over load current. Other features of the controller include over-current and under-voltage protection, internal temperature compensation, programmable voltage offset, and dynamic VID circuitry. For more information about the ISL6565B, consult the data sheet [1].

The ISL6605 is a high frequency, MOSFET driver, which drives multiple N-channel power MOSFETs. With a 4A sink current capability, fast rise and fall times, and short dead times, the ISL6605 can drive up to three upper and three lower MOSFETs efficiently, pushing load currents as high as 40A per phase. With the addition of adaptive shoot through technology, the ISL6605 is the premium driver to use with the ISL6565B controller to create a full power management solution. For further details on the ISL6605, consult the data sheet [2].

The Intersil multi-phase family controller and driver portfolio continues to expand with new selections to better fit our customer's needs. Refer to our web site for updated information: [www.intersil.com](http://www.intersil.com).

## ISL6565B VRD Reference Design

The evaluation kit consists of the ISL6565BEVAL1 evaluation board, associated data sheets on the ISL6565B controller and ISL6605 driver, as well as this application note. The evaluation board is designed to meet the output voltage and current specifications, shown in Table 1, with the VID DIP switches (U7 or U8) set to 100101 (1.400V).

TABLE 1. ISL6565BEVAL1 DESIGN PARAMETERS

PARAMETER	MAX	TYPICAL	MIN
No Load V <sub>CORE</sub> Regulation	1.400V	1.380V	1.360V
V <sub>CORE</sub> Tolerance	+20mV		-20mV
Load Line Slope		1.0m $\Omega$	
Continuous Load Current	5A		
Load Current Step	95A		
Load Current Transient	100A/ $\mu$ s		

The evaluation board provides convenient test points, two types of power supply connectors, a dynamic VID test circuit, and an on-board transient load generator to facilitate the evaluation process. On board LEDs are present to indicate the status of the PGOOD and OVP signals. The board is configured for down conversion from 12V to the DAC setting.

The printed circuit board is implemented in 4-layer, 1-ounce copper. Layout plots and part lists are provided at the end of the application note for this design.

## Quick Start Evaluation

### VID Setup

The ISL6565BEVAL1 board has two options for VID selection, a Static VID mode and a Dynamic VID mode. When in static VID mode the VID code, set by the Static DIP switch (U7), will not change during operation. If the dynamic VID mode is chosen, the regulator will start up with the VID code dictated by the Dynamic VID DIP switch (U8). This VID code can then be changed during the operation of the regulator to test the dynamic VID circuitry of the ISL6565B. Toggling the VID SELECT switch (S6) will change between the two modes (static and dynamic) of operation.

The Static and Dynamic VID DIP switches (U7 and U8) are preset to 100101 (1.400V). If another output voltage level is desired, refer to page 14 of the ISL6565B data sheet for the complete DAC table and change the VID switches accordingly. **Note that changing the VID states will change the dynamics of the load generator.**

**Jumper Setup**

There are two jumpers on the ISL6565BEVAL1 that must be populated before the board is powered. J1 selects the VCC voltage to the ISL6565B controller. This jumper is preset to 5V, but can be changed to 12V if desired. J2 sets the method by which the ENLL pin of the controller will be connected. This jumper is preset to the 5V setting, so that this pin is always connected high. This jumper can only be changed to the VID setting if the dynamic VID circuit is in use. Before connecting the power supplies to the board, place switches S1 and S2 in the “OFF” position.

**Input Power Connections**

The ISL6565BEVAL1 includes two different methods for powering up the board. The first method allows for the use of an ATX power supply. The 20-pin header, J13, allows for the connection of the main ATX power connector, while the 4-pin header, J11, connects the 12V AUX power. It is very important that both connections are secure and the S1 and S2 switches are in the OFF position before switching on the ATX supply.

The second method of powering the ISL6565BEVAL1 board is with bench-top power supplies. Three female-banana jacks are provided for connection of bench-top supplies. Connect the +5V terminal to J8, +12V terminal to J9, and the common ground to terminal J10. Voltage sequencing is not required when powering the evaluation board.

Once power is applied to the board, the PGOOD LED indicator will begin to illuminate red. With S1 in the OFF position, the ENABLE input of the ISL6565B is held low and the startup sequence is inhibited.

**Power Output Connections**

The ISL6565BEVAL1 output can be exercised using either resistive or electronic loads. Copper alloy terminal lugs provide connection points for loading. Tie the positive load connection to VCORE, terminals J3 and J4, and the negative to ground, terminals J5 and J6. A shielded scope probe test point, J7, allows for inspection of the output voltage, VCORE.

**Enabling the Controller**

In order to enable the controller all of the previous steps mentioned in the “Quick Start Evaluation” section must have been followed. If these steps have been properly followed, the regulator is enabled by toggling the ENABLE switch (S1) to the ON position. When S1 is switched, the voltage on the EN pin of the ISL6565B will rise above the ENABLE threshold of 1.31V and the controller will begin its digital soft start sequence. The output voltage ramps up to the programmed VID setting, at which time the PGOOD indicator will switch from red to green.

**On-Board Load Transient Generator**

Most bench-top electronic loads are not capable of producing the current slew rates required to emulate modern microprocessors. For this reason, a discrete transient load generator is provided on the evaluation board, see Figure 1. The generator produces a load pulse of 225μs in duration with a period of 27ms. The pulse magnitude is approximately 95A with rise and fall slew rates of approximately 100A/μs as configured. The short load current pulse and long duty cycle is required to limit the power dissipation in the load resistors (R47-R51) and MOSFETs (Q21, Q22). To engage the load generator simply place switch SW2, in the “ON” position.

If the DAC code is changed from 100101(1.400V), the transient generator dynamics must be adjusted relative to the new output voltage level. Place a scope probe in TP9 to measure the voltage across the load resistors and the dV/dt across them as well. Adjust the load resistors, R34-R38, to achieve the correct load current level. Change resistors R30-R33 to increase or decrease the dI/dt as required to match the desired dI/dt profile.

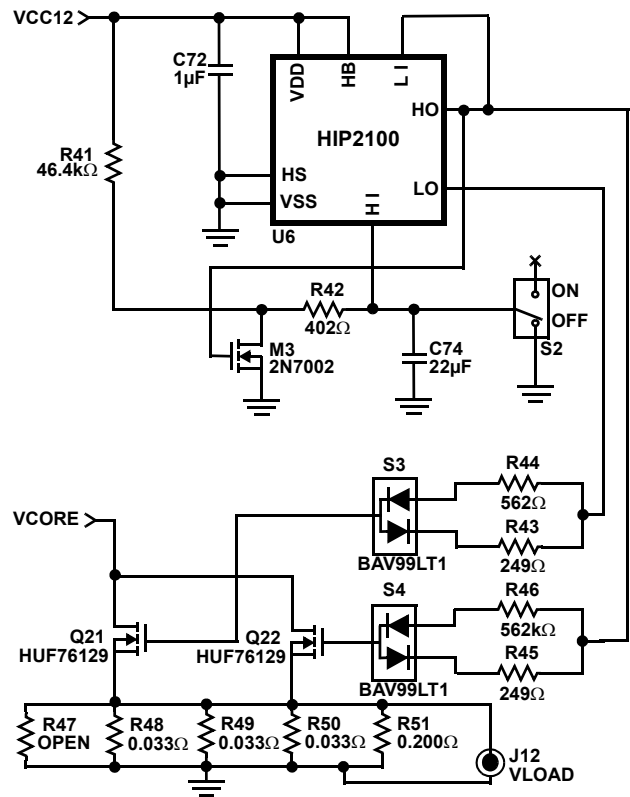

FIGURE 1. LOAD TRANSIENT GENERATOR

## ISL6565B VRD Performance

### Soft-Start Interval

The typical start-up waveforms for the ISL6565BEVAL1 are shown in Figure 2. The waveforms represented in this image show the soft-start sequence of the regulator starting into a 100A load with the DAC set to 100101 (1.40V). Before the soft-start interval begins, VCC is above POR and ENLL is a logic high. With these two conditions met, throwing the ENABLE switch into the ON position causes the voltage on the EN pin to rise above the ISL6565B's enable threshold, beginning the soft-start sequence. For a fixed time of 1ms, VCORE does not move due to the manner in which soft-start is implemented within the controller. After this delay, VCORE begins to ramp linearly toward the DAC voltage. With the converter running at 300kHz, this ramp takes approximately 5ms, during which time the input current, ICC12, also ramps slowly due to the controlled building of the output voltage.

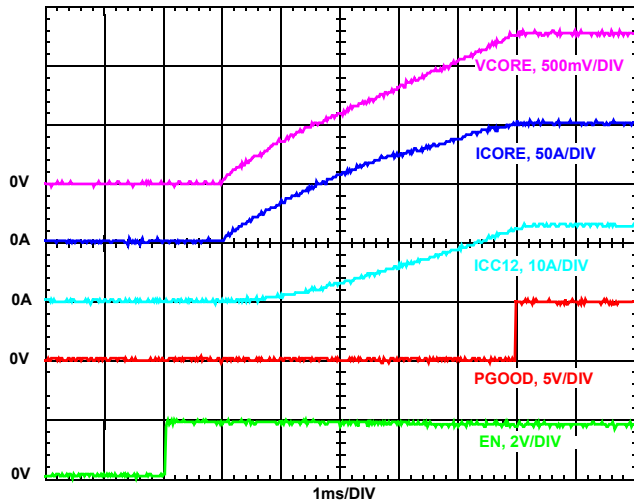

FIGURE 2. SOFT-START INTERVAL WAVEFORMS

Once VCORE reaches the DAC set point, the internal pull down on the PGOOD pin is released. This allows a resistor from PGOOD to VCC to pull PGOOD high and the PGOOD LED indicator changes from red to green.

### Transient Response

The ISL6565BEVAL1 design parameters require the regulator to support a 95A maximum load step to a 5A continuous load. This load step will have a maximum slew rate of approximately 100A/μs on both the rising and falling edges. The on-board load transient generator is designed to provide the specified load step, simulating the actual conditions seen at the CPU socket on a motherboard.

During the transient the core voltage is required to be regulated with a load line of 1mΩ and a tolerance of ±20mV around this load line. In order to meet these design parameters the controller VID is programmed to the maximum no load voltage of 1.400V (100101). A 4.32kW resistor (R7) is placed between the OFS pin and ground to

create a negative 20mV offset, regulating VCORE to the typical no load voltage of 1.380V specified in Table 1. Load line regulation is supported by the ISL6565B through the use of a resistor (R13) connected between the FB and VDIFF pins. The average current of the three active channels flows out of the FB pin across this resistor, and creates a voltage drop proportional to the output current of the converter. This voltage drop actively changes the position of the core voltage as the output current changes, creating an output voltage droop. For this design, the voltage droop is programmed to meet the set load line of 1mΩ.

The leading edge transient response of the ISL6565BEVAL1, which meets the design specifications of Table 1, is shown in Figure 3. In order to obtain the load current waveform shown, a bench top load is providing a constant 5A, while the on-board transient generator is pulsing a 95A step for 225μs. When the load step occurs, the output capacitors provide the initial output current, causing VCORE to drop suddenly due to the ESR and ESL voltage drops in the capacitors. The controller immediately responds to this drop by increasing the PWM duty cycles to as much as 66%. The duty cycles then decrease to stabilize VCORE and the built in load line regulation holds the output voltage at the programmed level of 1.280V.

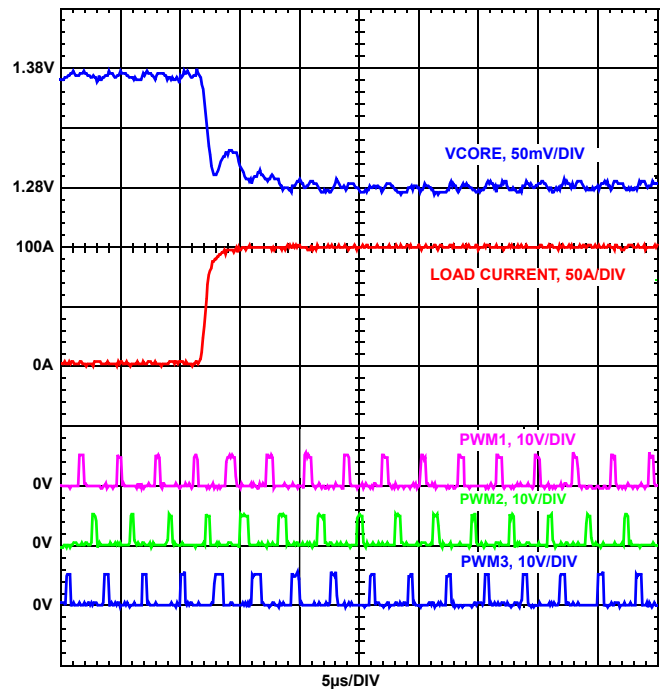

FIGURE 3. RISING EDGE TRANSIENT RESPONSE

At the end of the 225μs load pulse, the load current returns to the bench-top set level of 5A. The transient response to this falling edge of the load is shown in Figure 4. When the falling load step occurs, the output capacitors must absorb the inductor current which can not fall at the same rate of the load step. This causes VCORE to rise suddenly due to the ESR and ESL voltage drops in the capacitors. The controller

immediately responds to this rise by decreasing the PWM duty cycles to zero, and then increasing them accordingly to regulate V<sub>CORE</sub> to the programmed 1.375V level.

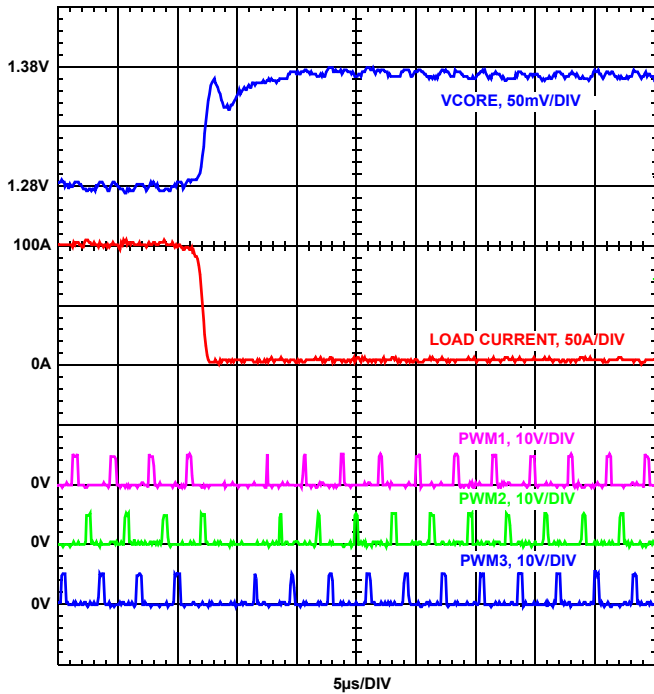

FIGURE 4. FALLING EDGE TRANSIENT RESPONSE

**Over-Current Protection**

The ISL6565B protects the CPU if an over-current event occurs by continuously monitoring the current through each channel. This is done by sensing the current through each channel's inductor and creating a proportional current, I<sub>SEN</sub>, which flows out of the ICOMMON pin. This I<sub>SEN</sub> current is set by resistor R21 to be 70μA when the maximum load current is applied. If the I<sub>SEN</sub> current for any channel ever increases above 110μA, the ISL6565B immediately places the PWM signals into a high impedance state.

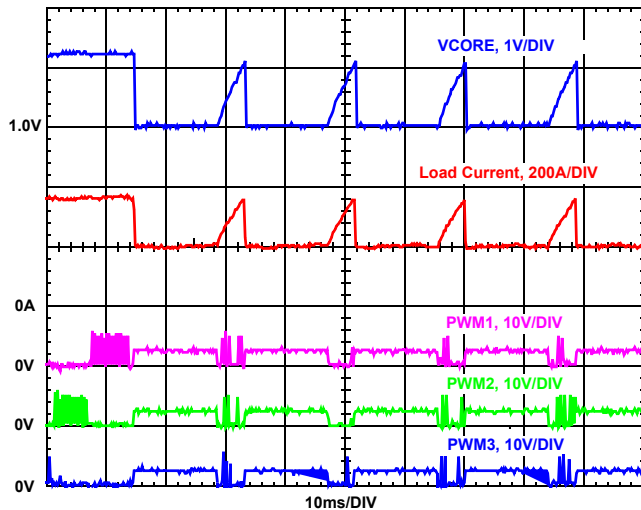

FIGURE 5. OVER-CURRENT PROTECTION

Placing the PWM signals into a high impedance state forces the ISL6605 drivers to turn the upper and lower MOSFETs off, causing V<sub>CORE</sub> to fall to 0V. The controller holds the PWM signals in this state for a period of 4096 switching cycles, which at 300kHz is 13.5ms. The controller then re-initializes the soft-start cycle. If the load that caused the over-current trip remains, another over-current trip will occur before the soft-start cycle completes. The controller will continue to try to cycle soft-start indefinitely until the load current is reduced, or the controller is disabled. This operation is shown in Figure 5.

**VID on the Fly**

The ISL6565B is designed to monitor the VID code from the Intel CPU at all times, and to actively adjust the output voltage if the VID code should change during normal operation. To do this, the controller checks the VID inputs six times every switching cycle. If the VID code is found to have changed, the controller will begin executing 12.5mV DAC steps six times per cycle until VID and DAC are equal.

To simulate a VID transition, the ISL6566BEVAL1 has an on-board dynamic VID generator which simulates a VID-on-the-fly transition. Using the dynamic VID circuit requires first toggling the VID SELECT switch (S6) to the DYNAMIC position. The DYNAMIC VID dip switch chooses the starting VID code for the controller. Pressing the DYNAMIC SWITCH (S5) button begins the VID transition. The on-board circuit is designed to transition the VID code 450mV below the DYNAMIC VID DIP switch code in 12.5mV steps that occur every 5μs.

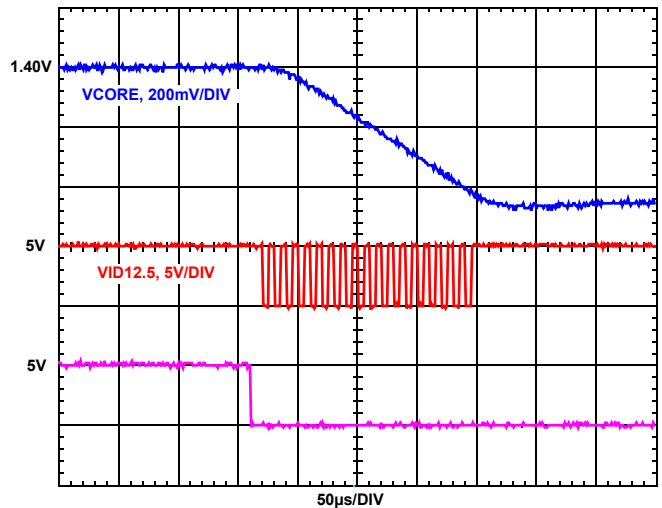
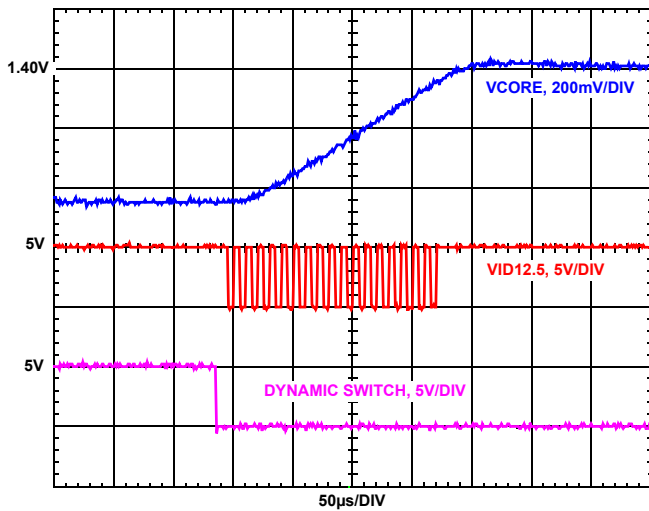

FIGURE 6. VID-ON-THE-FLY TRANSITION FROM 1.40V TO 0.950V

Figure 6 shows a VID-on-the-fly transition from 1.40V (100101) to 0.950V(001011). This transition begins with the DYNAMIC SWITCH signal transition from 5V to 0V. Every time the VID code changes, the VID12.5 signal transitions between 0V and 5V. During the VID transitions, as Figure 6 shows, the controller smoothly transitions from one code to the next until the final code of 0.9500V is reached.

Pressing the DYNAMIC SELECT switch again returns the VID code to the original setting of 1.40V, as Figure 7 shows. This transition is handled smoothly by the ISL6565B with no overshoot as the final code is reached.



**FIGURE 7. VID-ON-THE-FLY TRANSITION FROM 0.950V TO 1.40V**

## Efficiency

The efficiency of the ISL6565BEVAL1 board, loaded from 5A to 105A, is plotted in Figure 8. Measurements were performed at room temperature and taken at thermal equilibrium with **300LFM OF AIR FLOW**. The efficiency peaks just below 90% at 30A and then levels off steadily to approximately 82% at 105A. The use of air flow is recommended for Intel’s microprocessor designs, with 300LFM as the mean. The addition of air flow keeps the components cooler and raises the overall efficiency across the load range.

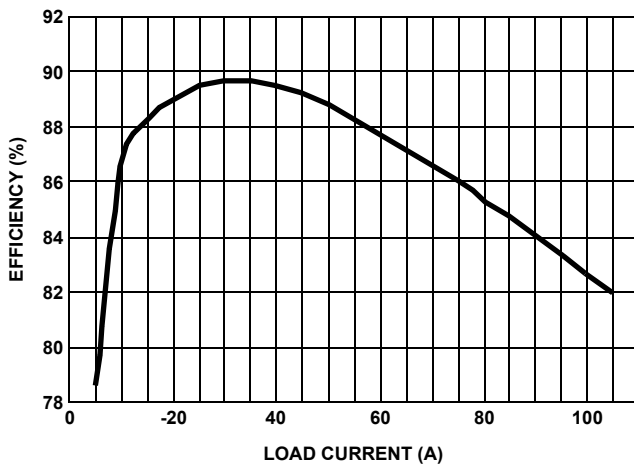

**FIGURE 8. EFFICIENCY vs LOAD CURRENT**

## Thermal Performance

Table 2 shows the laboratory measured upper and lower MOSFET, inductor, and driver temperatures at 100A of load current. The measurements were performed at room temperature (26 °C) and taken at thermal equilibrium with **300LFM OF AIR FLOW**.

**TABLE 2. THERMAL DATA AT 100A LOAD**

COMPONENT	PHASE 1	PHASE 2	PHASE 3
Upper MOSFETs	73°C	65°C	76°C
Lower MOSFETs	72°C	60°C	73°C
Driver	63°C	62°C	68°C
Inductor	59°C	56°C	58°C

## Summary

The ISL6565BEVAL1 is an adaptable evaluation tool which showcases the performance of the ISL6565B and ISL6605 chipset. Designed to meet the performance requirements of Intel’s next generation designs, the board allows the user the flexibility to configure the board for current as well as future microprocessor offerings. The following pages provide a schematic of the board, bill of materials and layout drawings to support implementation of this solution.

## References

Intersil documents are available on the web at [www.intersil.com](http://www.intersil.com).

- [1] ISL6565 Data Sheet, Intersil Corporation, File No. FN9135
- [2] ISL6605 Data Sheet, Intersil Corporation, File No. FN9091

## Schematic

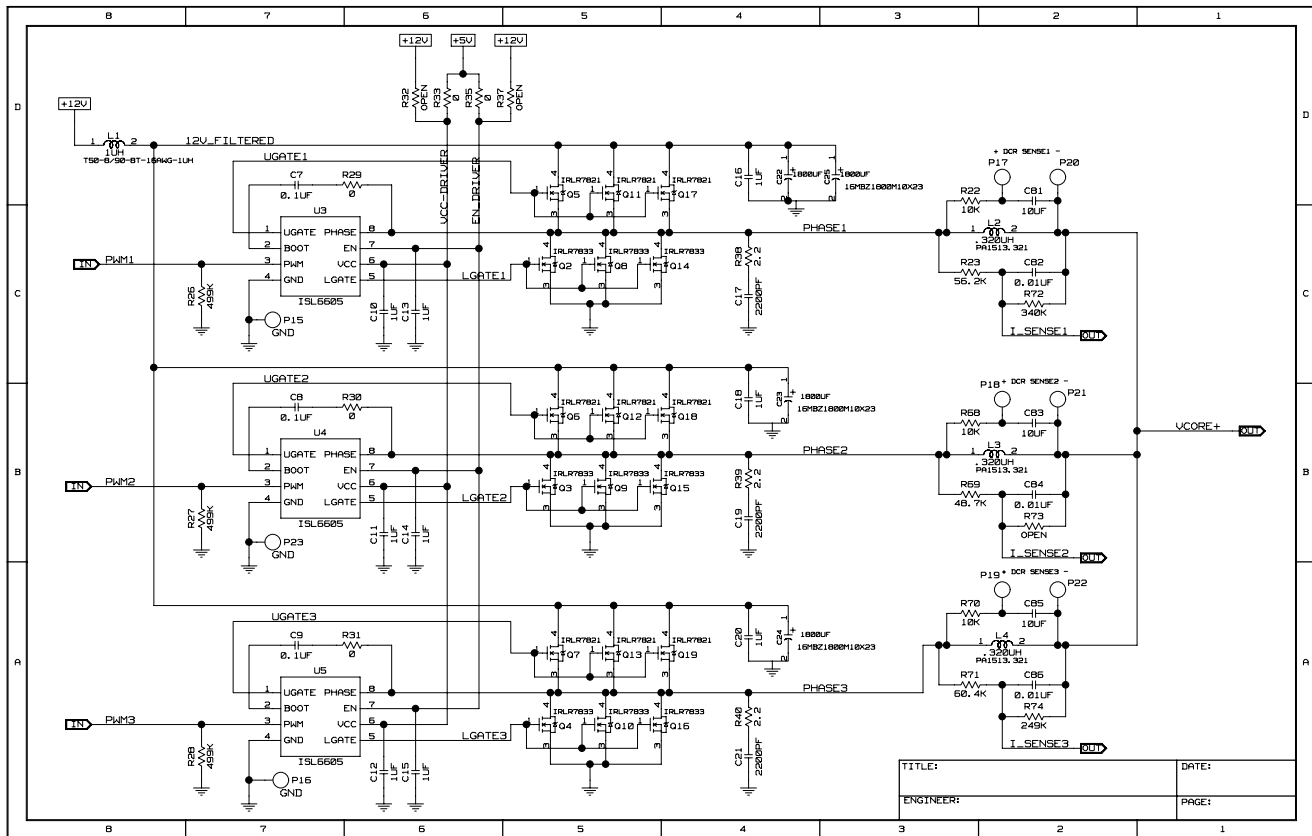
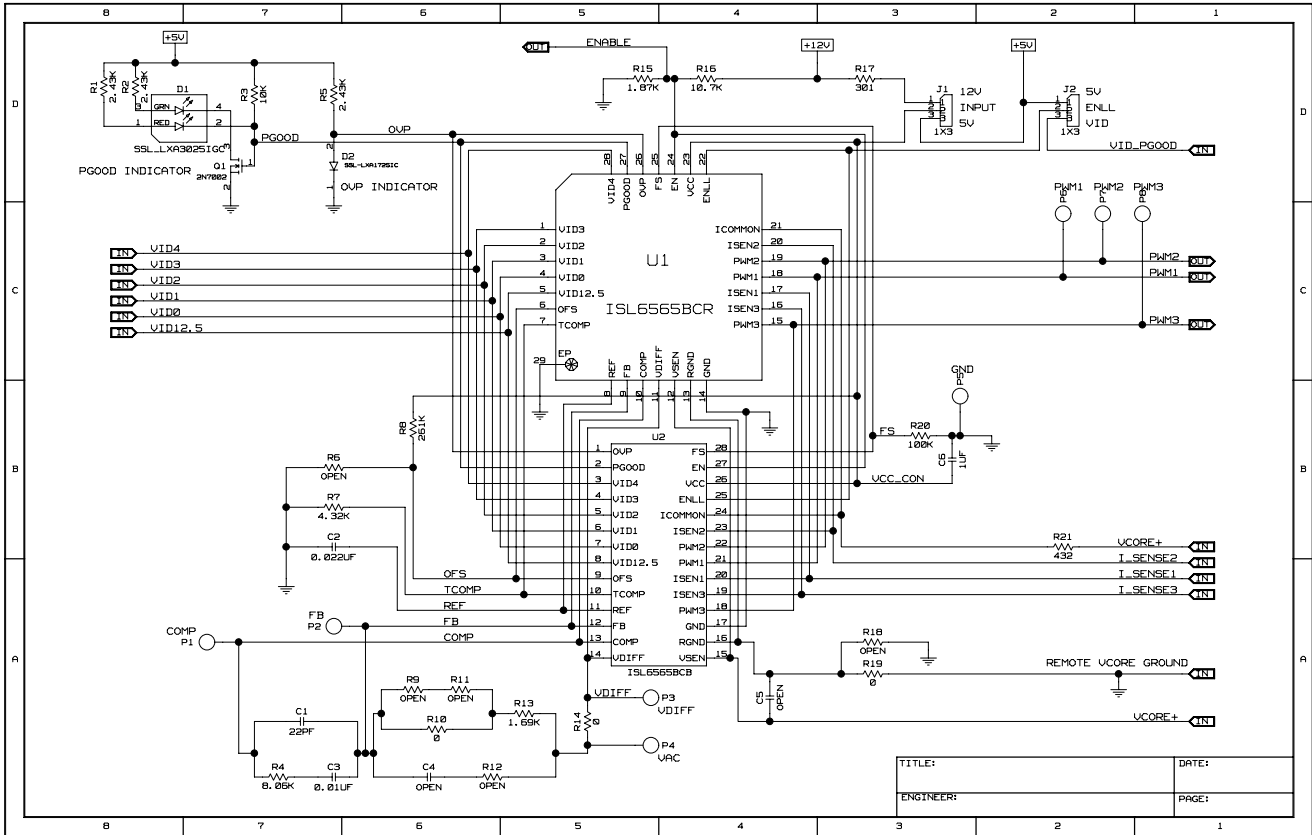

# Application Note 1126

## Schematic (Continued)

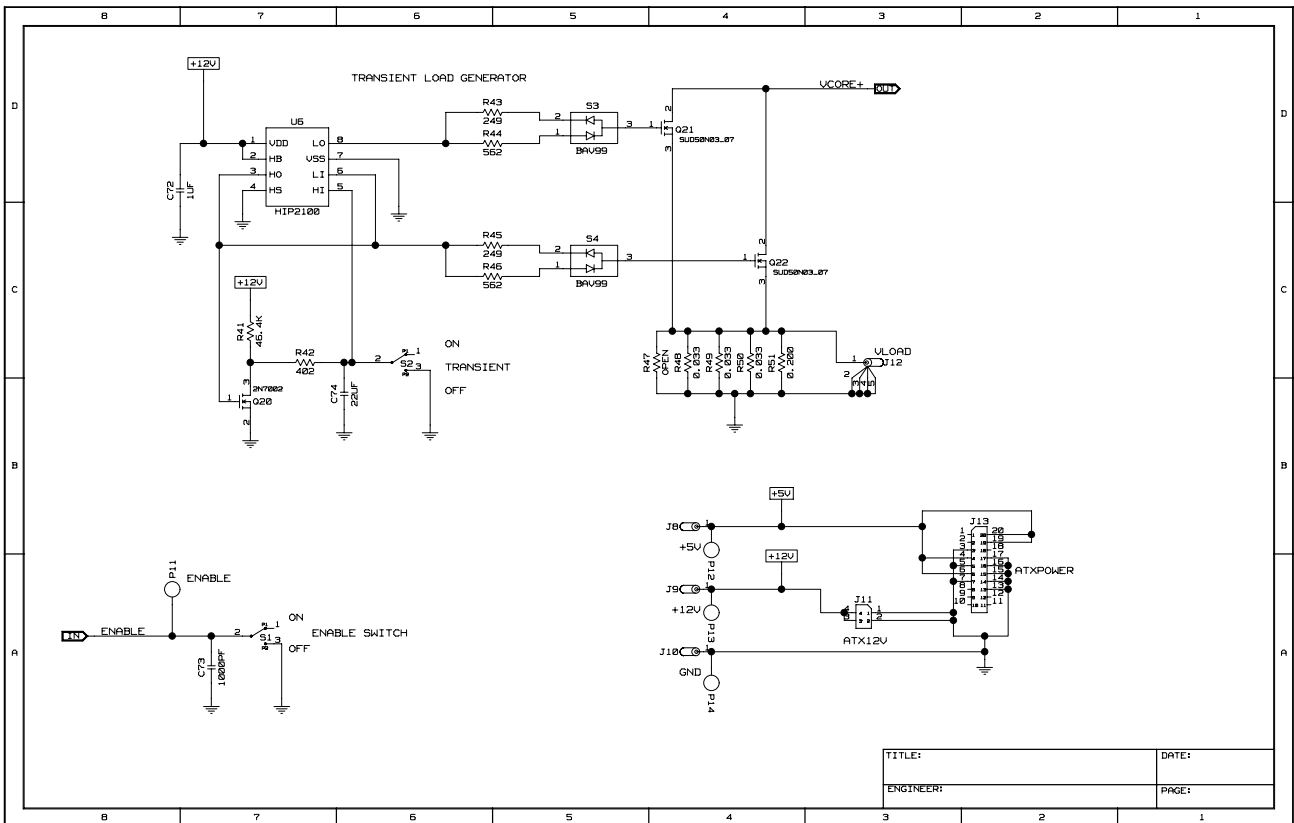
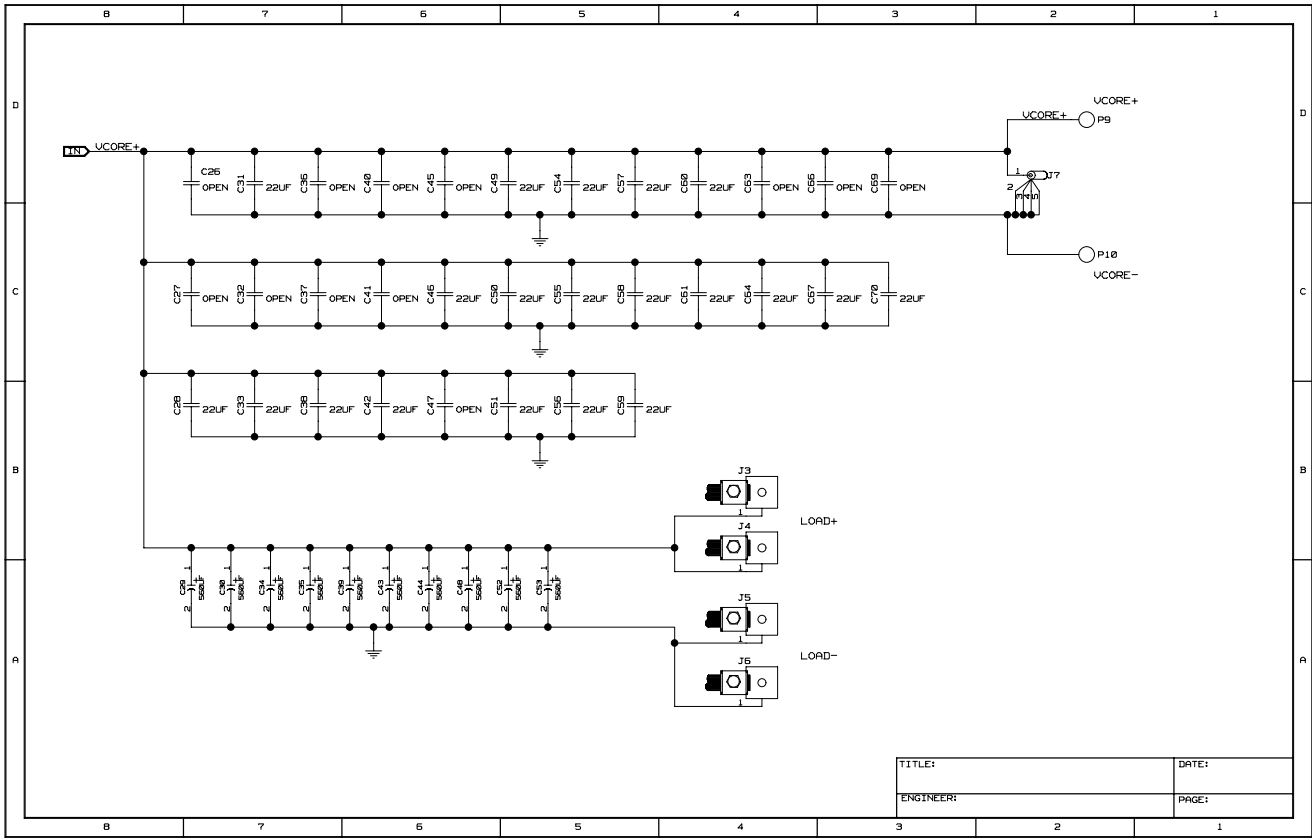

# Application Note 1126

## Schematic (Continued)

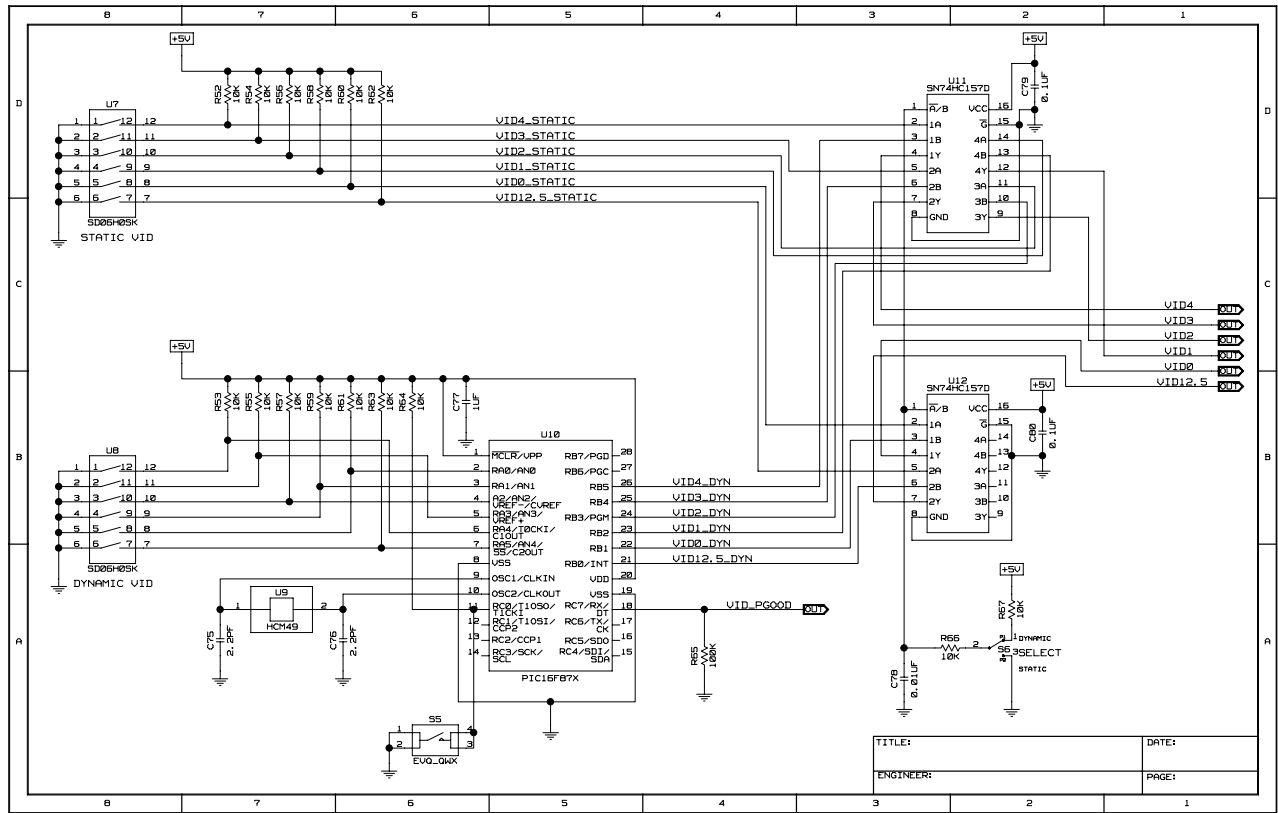

## Bill of Materials

QTY	REFERENCE	VALUE	DESCRIPTION	VENDOR	PART NO.	PACKAGE
1	C1	22pF	Capacitor, Ceramic, 50V, X7R, 10%	Various		0805
1	C2	0.022μF	Capacitor, Ceramic, 50V, X7R, 10%	Various		0805
1	C3	0.01μF	Capacitor, Ceramic, 50V, X7R, 10%	Various		0805
1	C4	DNS	Capacitor, Ceramic	Various		0805
1	C5	DNS	Capacitor, Ceramic	Various		0603
7	C6, C10-C15	1.0μF	Capacitor, Ceramic, 16V, X7R, 10%	Various		0805
3	C7-C9	0.1μF	Capacitor, Ceramic, 50V, X7R, 10%	Various		0805
4	C16, C18, C20, C72	1.0μF	Capacitor, Ceramic, 16V, X7R, 10%	Various		1206
3	C17, C19, C21	2200pF	Capacitor, Ceramic, 50V, X7R, 10%	Various		0805
4	C22-C25	1800μF	Capacitor, AL Electrolytic, 16V	Rubycon	16MBZ1800M10X23	Thru Hole
12	C26, C27, C32, C36, C37, C40, C41, C45, C47, C63, C66, C69	DNS	Capacitor, Ceramic	Various		1206
20	C28, C31, C33, C38, C42, C46, C49-C51, C54-C61, C64, C67, C70	22μF	Capacitor, Ceramic, 6.3V, X5R, 20%	Various		1206



## Application Note 1126

### Bill of Materials (Continued)

QTY	REFERENCE	VALUE	DESCRIPTION	VENDOR	PART NO.	PACKAGE
10	C29, C30, C34, C35, C39, C43, C44, C48, C52, C53	560 $\mu$ F	Capacitor, OS-CON, 4V	Sanyo	4SEPC560MX	Thru Hole
1	C73	1000pF	Capacitor, Ceramic, 50V, X7R, 10%	Various		0603
1	C74	22 $\mu$ F	Capacitor, Ceramic, 16V, X5R, 20%	TDK	C3225X5R1C226M	1210
2	C75, C76	2.2pF	Capacitor, Ceramic, 50V, X7R, 10%	Various		0603
1	C77	1.0 $\mu$ F	Capacitor, Ceramic, 10V, X7R, 10%			0805
4	C78, C82, C84, C86	0.01 $\mu$ F	Capacitor, Ceramic, 16V, X7R, 10%	Various		0603
2	C79, C80	0.1 $\mu$ F	Capacitor, Ceramic, 50V, X7R, 10%	Various		0603
3	C81, C83, C85	10 $\mu$ F	Capacitor, Ceramic, 10V, X7R, 10%	Various		1206
1	D1		Red/Green LED	Lumex	SLL-LXA3025IGC	SMT
1	D2		Red LED	Lumex	SLL-LXA1725IC	SMT
2	J1, J2		Molex HDR 1x3 1MT Hole	Molex		Thru Hole
4	J3-J6		Terminal Connector	Burndy	KPA8CTP	Solder Mount
2	J7, J12		Probe Socket	Tektronix	1314353-00	Thru Hole
2	J8-J9		Female Banana Connector, Red	Johnson Components	111-0702-001	Screw On
1	J10		Female Banana Connector, Black	Johnson Components	111-0703-001	Screw On
1	J11		2x2 Power HDR 1MTG Hole	Molex	39-29-9042	Thru Hole
1	J13		2x10 Power Conn-1MTG Pin	Molex	39-29-9203	Thru Hole
1	L1	1.0 $\mu$ H	Inductor, T50-8/90 core, 8 turns AWG16	Micrometals	T50-8/90	Thru Hole
3	L2-L4	0.320 $\mu$ H	Inductor, 13x13mm	Pulse	PA1513.321	Surface Mount
15	P1-P4, P6-P9, P11, P17-P22		Small Test Point	Jolo	SPCJ-123-01	Thru Hole
8	P5, P10, P12-P16, P23		Turret Test Point	Keystone	1514-2	Thru Hole
2	Q1, Q20		General Purpose MOSFET	Various	2N7002	SOT-23
9	Q2-Q4, Q8-Q10, Q14-Q16		Power MOSFET	International Rectifier	IRLR7833	TO-252AA
9	Q5-Q7, Q11-Q13, Q17-Q19		Power MOSFET	International Rectifier	IRLR7821	TO-252AA
2	Q21, Q22		Power MOSFET	Vishay	SUD50N03-07	TO-252AA
3	R1, R2, R5	2.43k $\Omega$	Resistor, 1%, 1/16W	Various		0603
19	R3, R22, R52-R64, R66-R68, R70	10k $\Omega$	Resistor, 1%, 1/16W	Various		0603
1	R4	8.06k $\Omega$	Resistor, 1%, 1/16W	Various		0603
6	R10, R14, R19, R29-R31	0 $\Omega$	Resistor, 1%, 1/16W	Various		0603
6	R6, R9, R11, R12, R18, R73	DNS	Resistor	Various		0603
1	R7	4.32k $\Omega$	Resistor, 1%, 1/16W	Various		0603
1	R8	261k $\Omega$	Resistor, 1%, 1/16W	Various		0603
1	R13	1.69k $\Omega$	Resistor, 1%, 1/16W	Various		0603

## Application Note 1126

### Bill of Materials (Continued)

QTY	REFERENCE	VALUE	DESCRIPTION	VENDOR	PART NO.	PACKAGE
1	R15	1.87kΩ	Resistor, 1%, 1/16W	Various		0603
1	R16	10.7kΩ	Resistor, 1%, 1/16W	Various		0603
1	R17	301Ω	Resistor, 1%, 1/8W	Various		1206
1	R20	100kΩ	Resistor, 1%, 1/16W	Various		0603
1	R21	432Ω	Resistor, 1%, 1/16W	Various		0603
1	R23	56.2kΩ	Resistor, 1%, 1/16W	Various		0603
3	R26-R28	499kΩ	Resistor, 1%, 1/16W	Various		0603
2	R32, R37	DNS	Resistor	Various		1206
2	R33, R35	0Ω	Resistor, 1%, 1/8W	Various		1206
3	R38-R40	2.2Ω	Resistor, 1%, 1/8W	Various		1206
1	R41	46.4kΩ	Resistor, 1%, 1/16W	Various		0603
1	R42	402Ω	Resistor, 1%, 1/16W	Various		0603
1	R43, R45	249Ω	Resistor, 1%, 1/16W	Various		0603
1	R44, R46	562Ω	Resistor, 1%, 1/16W	Various		0603
1	R47	DNS	Thick Film Chip Resistor	Various		2512
2	R48, R49, R50	0.033Ω	Thick Film Chip Resistor, 1%, 1W	Various		2512
1	R51	0.200Ω	Thick Film Chip Resistor, 1%, 1W	Various		2512
1	R65	100kΩ	Resistor, 1%, 1/16W	Various		0603
1	R69	48.7kΩ	Resistor, 1%, 1/16W	Various		0603
1	R71	60.4kΩ	Resistor, 1%, 1/16W	Various		0603
1	R72	340kΩ	Resistor, 1%, 1/16W	Various		0603
1	R74	249kΩ	Resistor, 1%, 1/16W	Various		0603
3	S1, S2, S6		Switch SPDT, Ultra Mini Toggle	C&K Components	GT11MSCKE	SMD
2	S3, S4		Dual Diode	Various	BAV99	SOT-23
1	S5		Momentary Pushbutton Switch	Panasonic	SW_EVQ_QWX	SMD
1	U1		Endura Multi-phase Controller	Intersil	ISL6565BCR	MLFP-28
1	U2	DNS	Endura Multi-phase Controller	Intersil	ISL6565BCB	SOIC-28W
3	U3, U4, U5		Endura Multi-phase Driver	Intersil	ISL6605CB	SO-8
1	U6		MOSFET Driver IC	Intersil	HIP2100IB	SO-8
2	U7, U8		Low Profile DIP Switch, SPST, 6 Position	C&K Components	SD06H0SK	SMT
1	U9		8.00MHz Quartz Crystal	Citizen	HCM49-8.000MABJT	SMD
1	U10		8-bit microcontroller	Microchip	PIC16F873A-SO	SOIC-32W
1	U11, U12		Quad 2-to-1 Line Data Selector/Multiplexer	Texas Instruments	SN74HC157D	SOIC-16

ISL6565BEVAL1 Layout

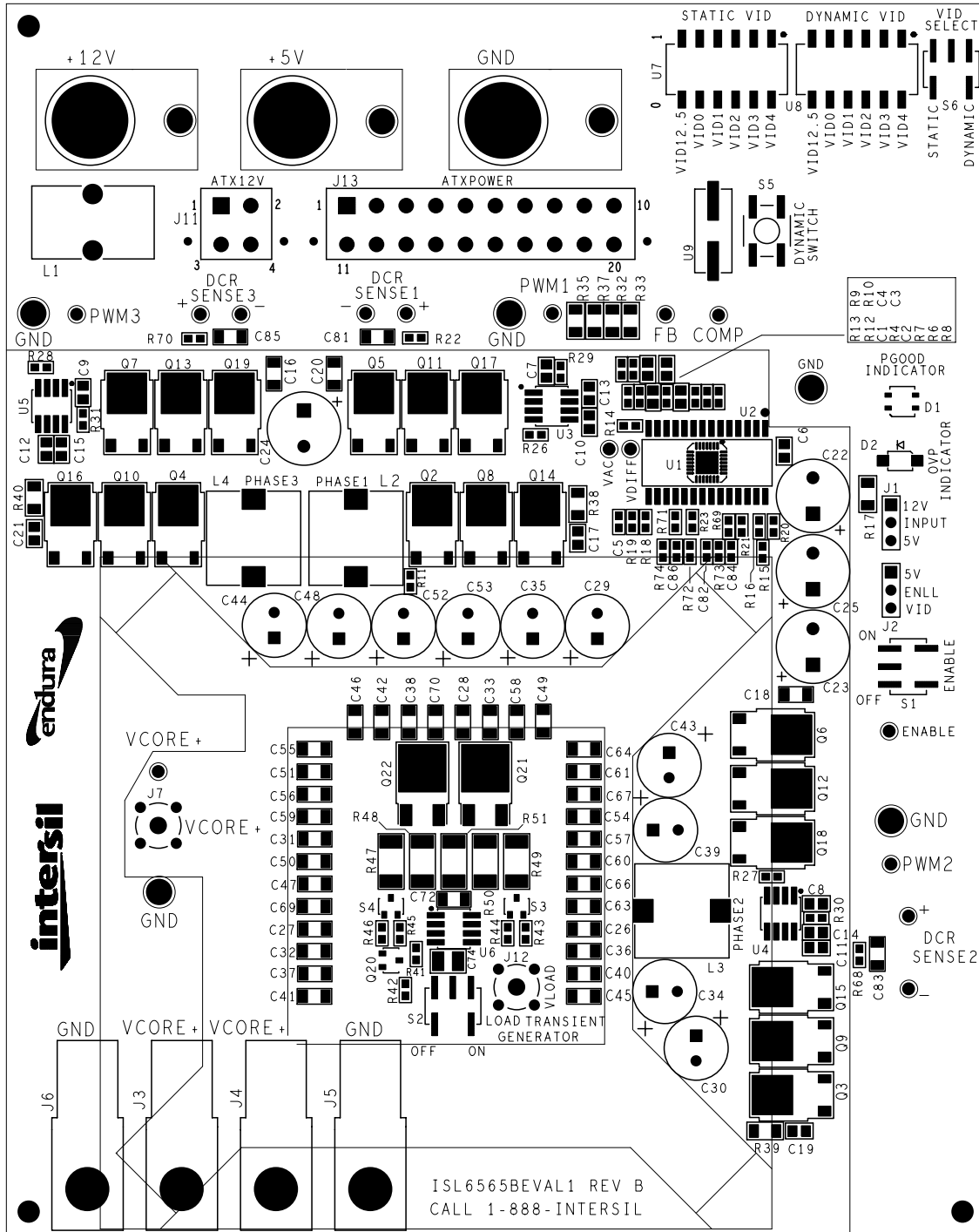

FIGURE 9. SILK SCREEN TOP

ISL6565BEVAL1 Layout (Continued)

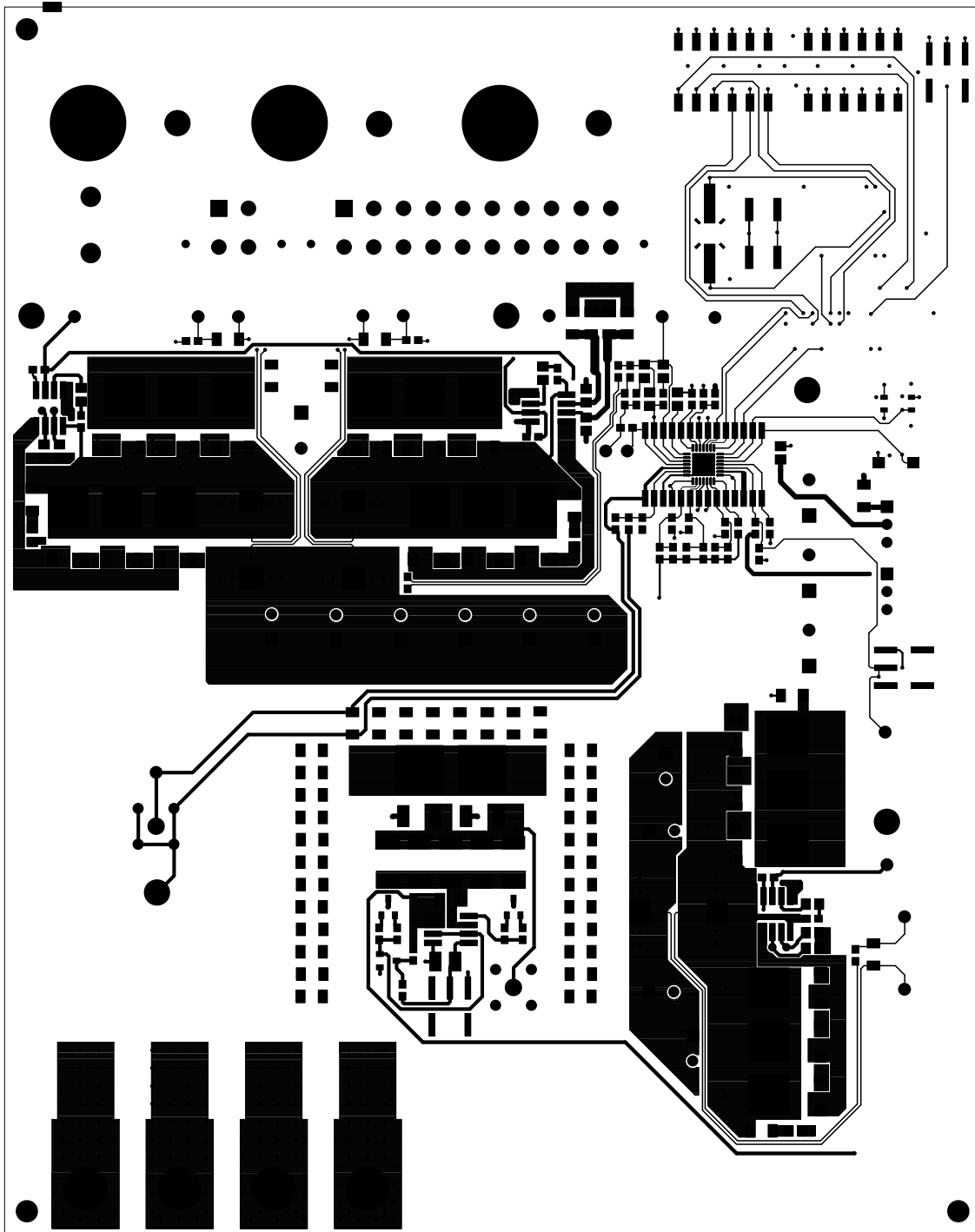

FIGURE 10. LAYER 1: TOP COPPER

ISL6565BEVAL1 Layout (Continued)

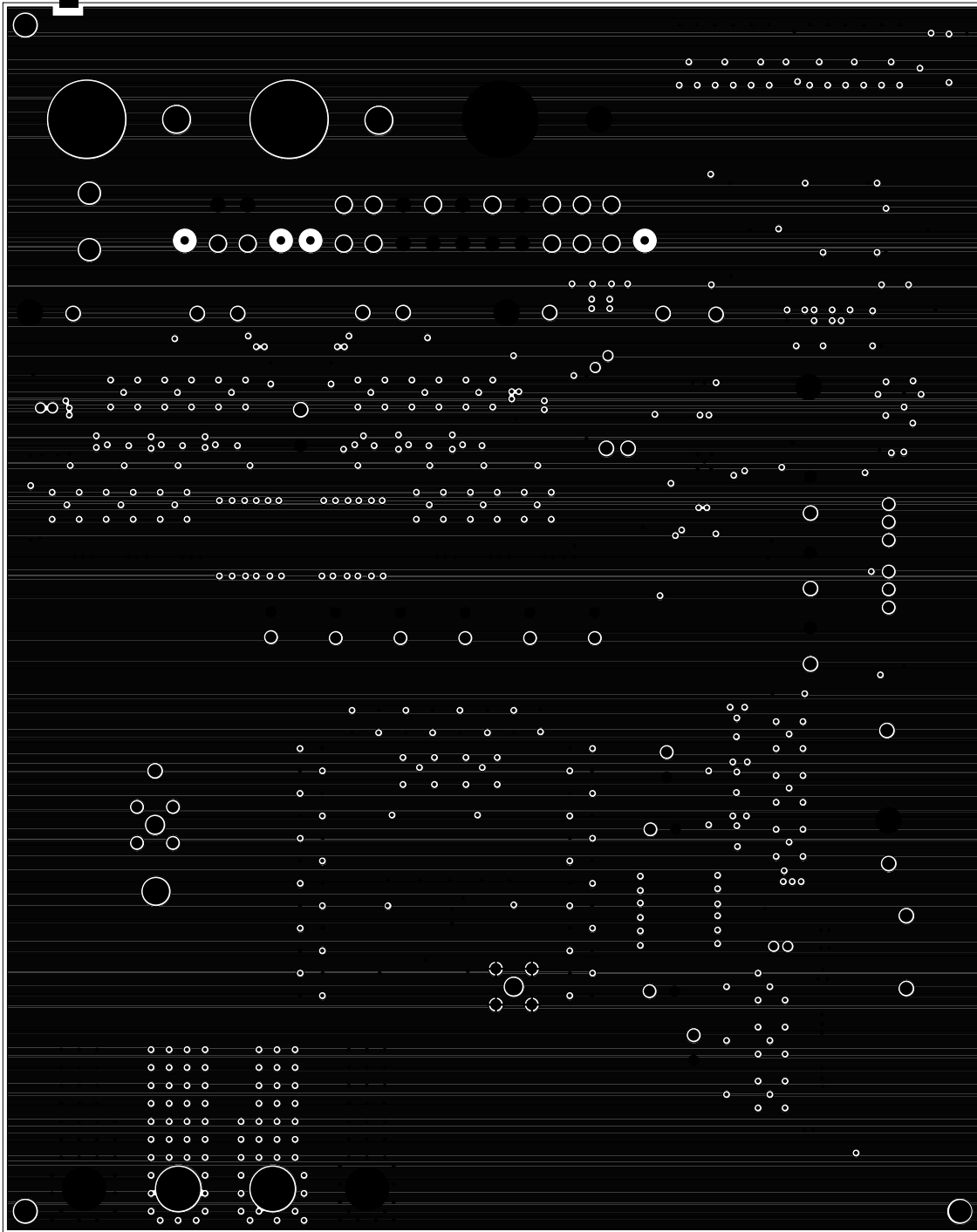

FIGURE 11. LAYER 2: GROUND PLANE

ISL6565BEVAL1 Layout (Continued)

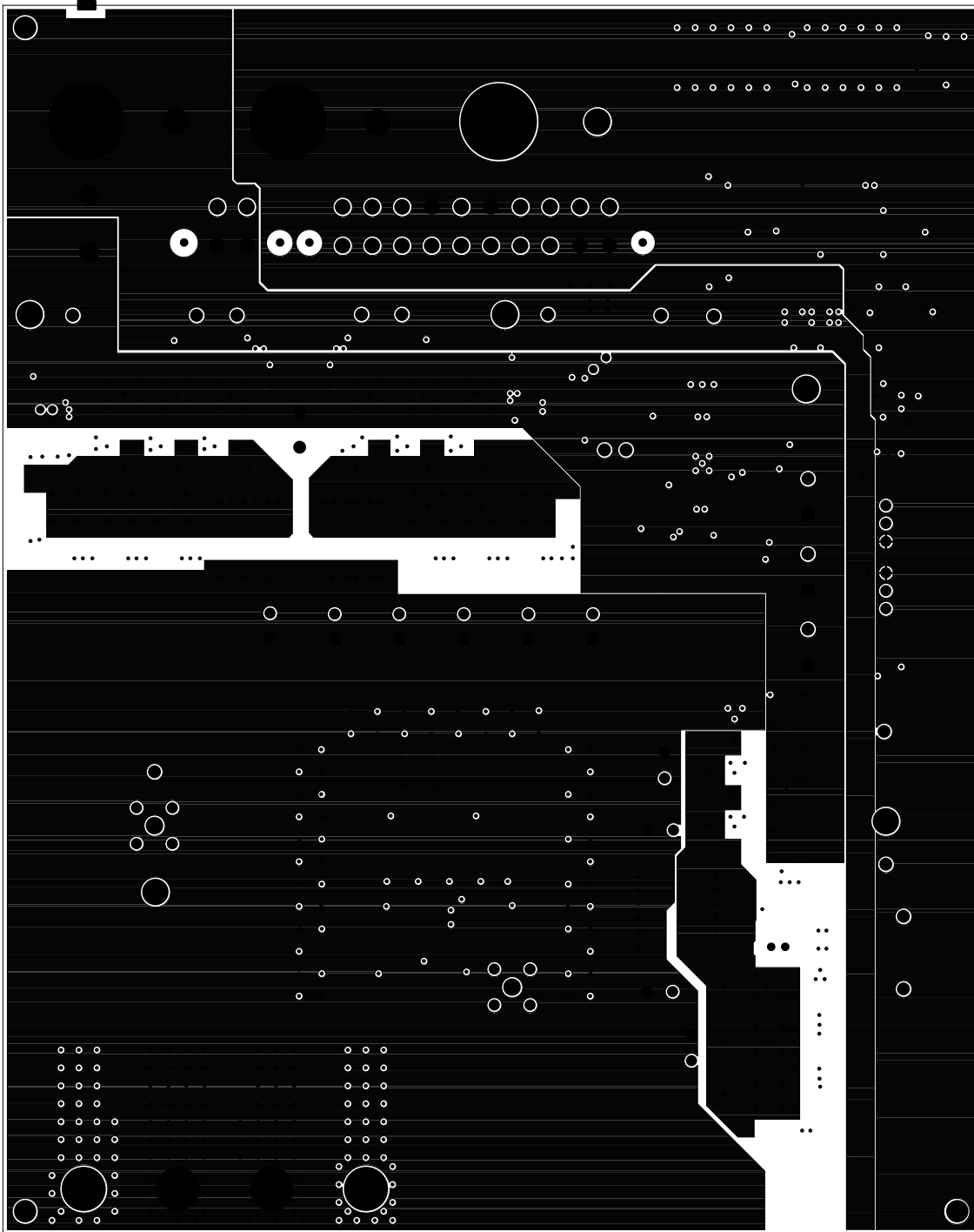

FIGURE 12. LAYER 3: POWER PLANE

ISL6565BEVAL1 Layout (Continued)

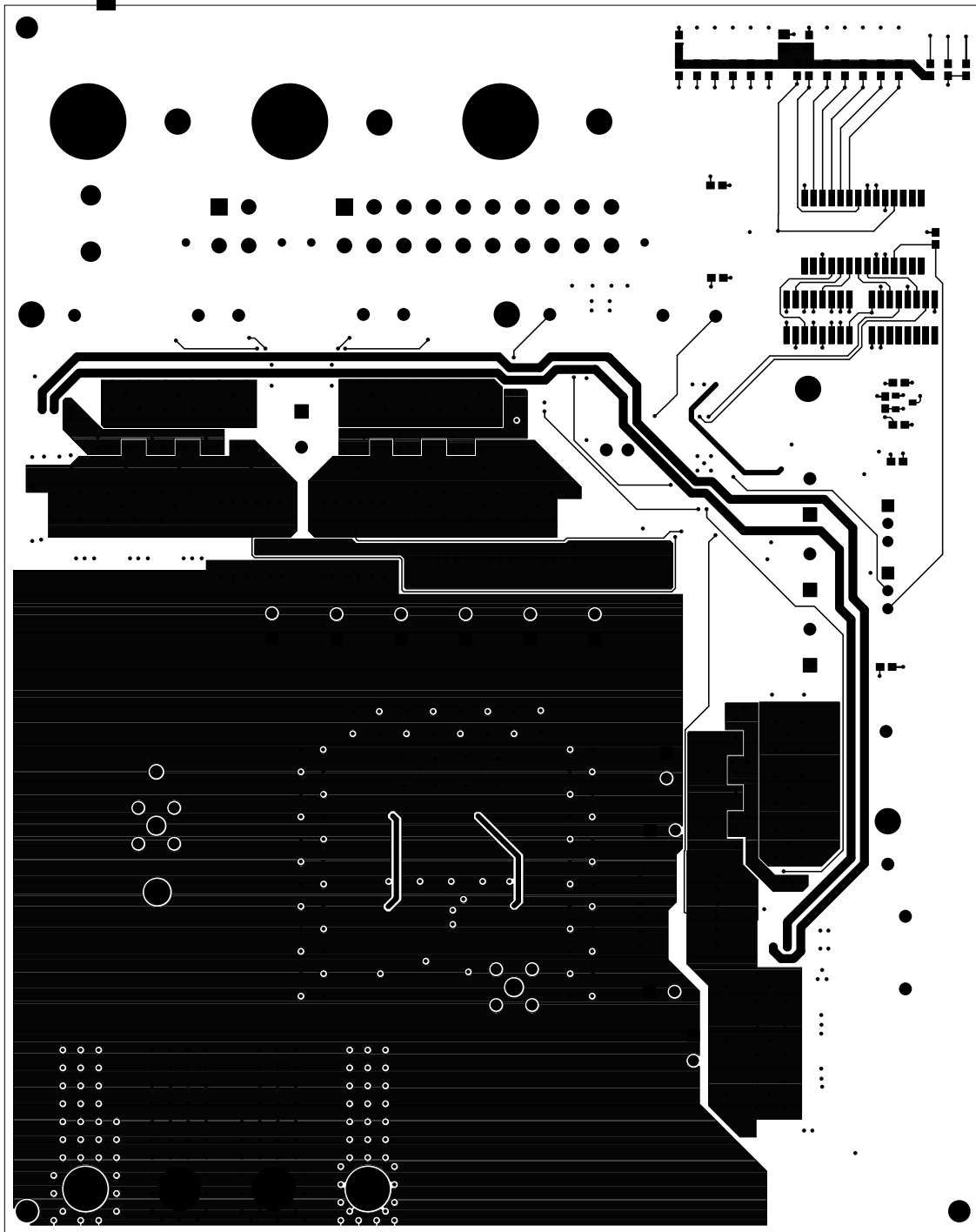

FIGURE 13. LAYER 4: BOTTOM COPPER

ISL6565BEVAL1 Layout (Continued)

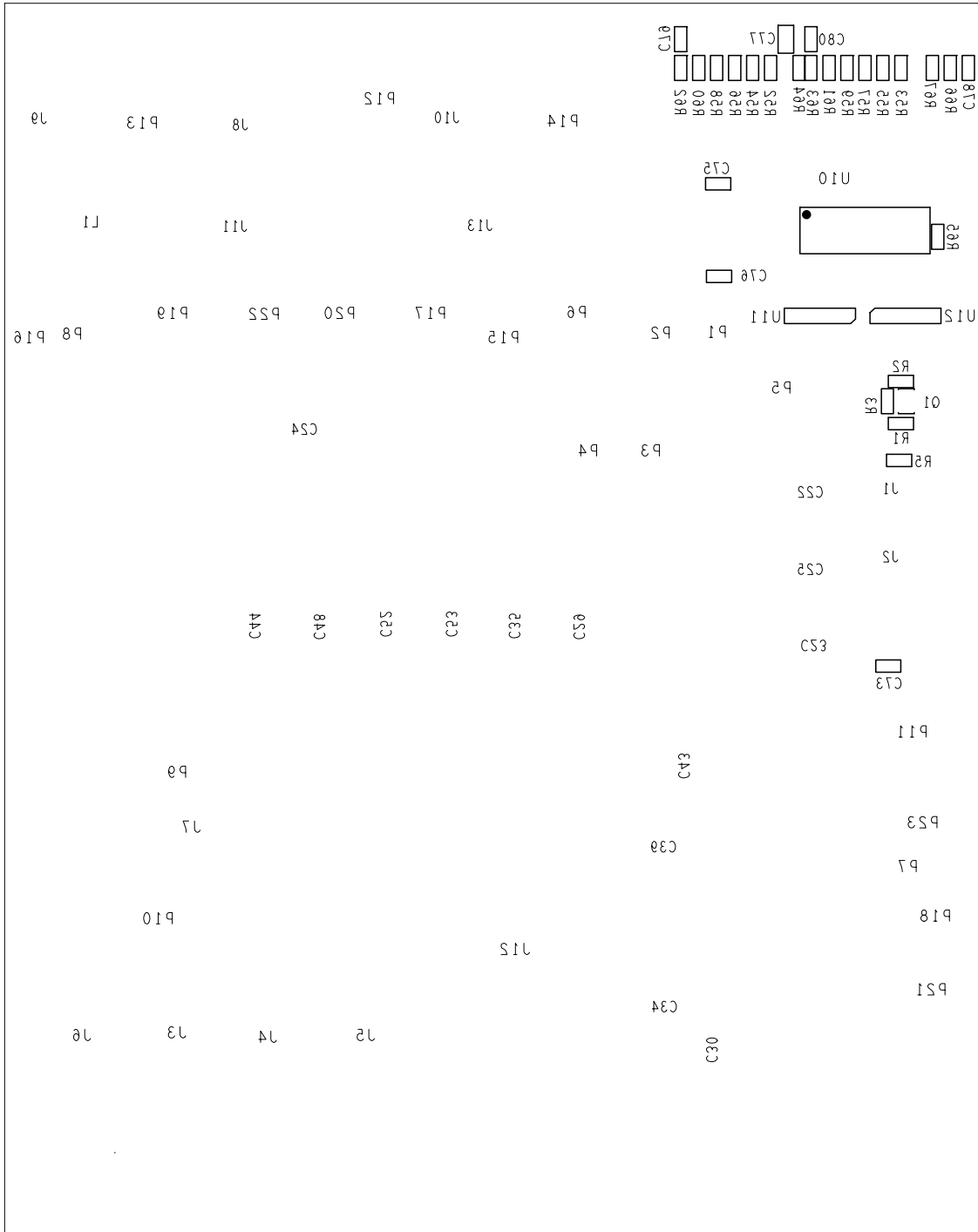

FIGURE 14. SILK SCREEN BOTTOM

All Intersil U.S. products are manufactured, assembled and tested utilizing ISO9000 quality systems. Intersil Corporation's quality certifications can be viewed at [www.intersil.com/design/quality](http://www.intersil.com/design/quality)

*Intersil products are sold by description only. Intersil Corporation reserves the right to make changes in circuit design, software and/or specifications at any time without notice. Accordingly, the reader is cautioned to verify that data sheets are current before placing orders. Information furnished by Intersil is believed to be accurate and reliable. However, no responsibility is assumed by Intersil or its subsidiaries for its use; nor for any infringements of patents or other rights of third parties which may result from its use. No license is granted by implication or otherwise under any patent or patent rights of Intersil or its subsidiaries.*

For information regarding Intersil Corporation and its products, see [www.intersil.com](http://www.intersil.com)