

CCE4510 Single Board

4-Channel IO-Link Master

The CCE4510 Single Board is a simple evaluation board for evaluating the CCE4510 IO-Link Master PHY.

**Specifications**

- 4 IO-Link Channels
- 8-32V Main Power Supply (24V typ.)
- 3.3V Power Supply
- Controlled by external Microcontroller via SPI or UART Interface

**Features**

- Two CCE4510 IO-Link Master PHYs
- Protection Circuitry
- Terminal Blocks to connect IO-Link Channels
- Channel Indicator LEDs
- External Sense / Gate Driver configuration
- Pin Header to connect Microcontroller
- All pins accessible via Pin Headers

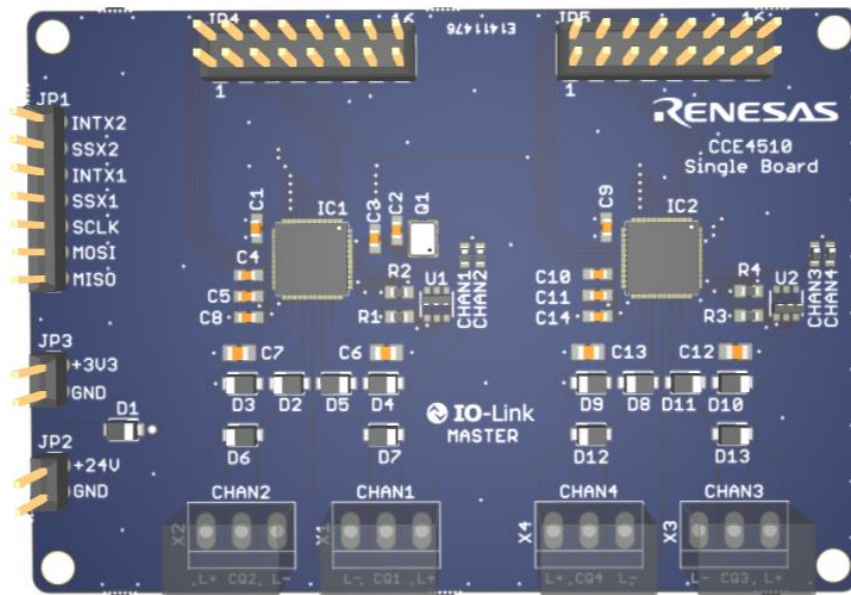

Figure 1. CCE4510 Single Board

## Contents

<b>1. Functional Description</b> .....	<b>3</b>
1.1 Power up sequence .....	3
<b>2. Board Design</b> .....	<b>4</b>
2.1 Schematic Diagram .....	4
2.2 Bill of Materials .....	5
2.3 Board Layout .....	6
<b>3. Ordering Information</b> .....	<b>8</b>
<b>4. Revision History</b> .....	<b>8</b>

## Figures

Figure 1. CCE4510 Single Board .....	1
Figure 2. Top Layer .....	6
Figure 3. Second Layer (GND) .....	6
Figure 4. Third Layer (Supply) .....	7
Figure 5. Bottom Layer .....	7

# 1. Functional Description

The CCE4510 Single Board contains two CCE4510 IO-Link Master PHYs which are controlled via an external Microcontroller. This can be done by SPI (JP1) or UART (JP4 / JP5).

To power up the Single Board, two Power Supplies are needed:

- VCC: 24V (8-32V) at JP2
- VDD: 3.3V at JP3

Both CCE4510 use the external sense / gate driver configuration and use two LEDs to indicate the status of the channels. The LED blinking sequence can be controlled by setting the corresponding registers of the CCE4510.

All Channels are protected with additional protection circuitry (TVS diodes and capacities) .

## 1.1 Power up sequence

For proper operation of the ICs, VDD must be powered up before VCC. Not respecting the power-up sequence may result in damage to the ICs.

## 2. Board Design

### 2.1 Schematic Diagram

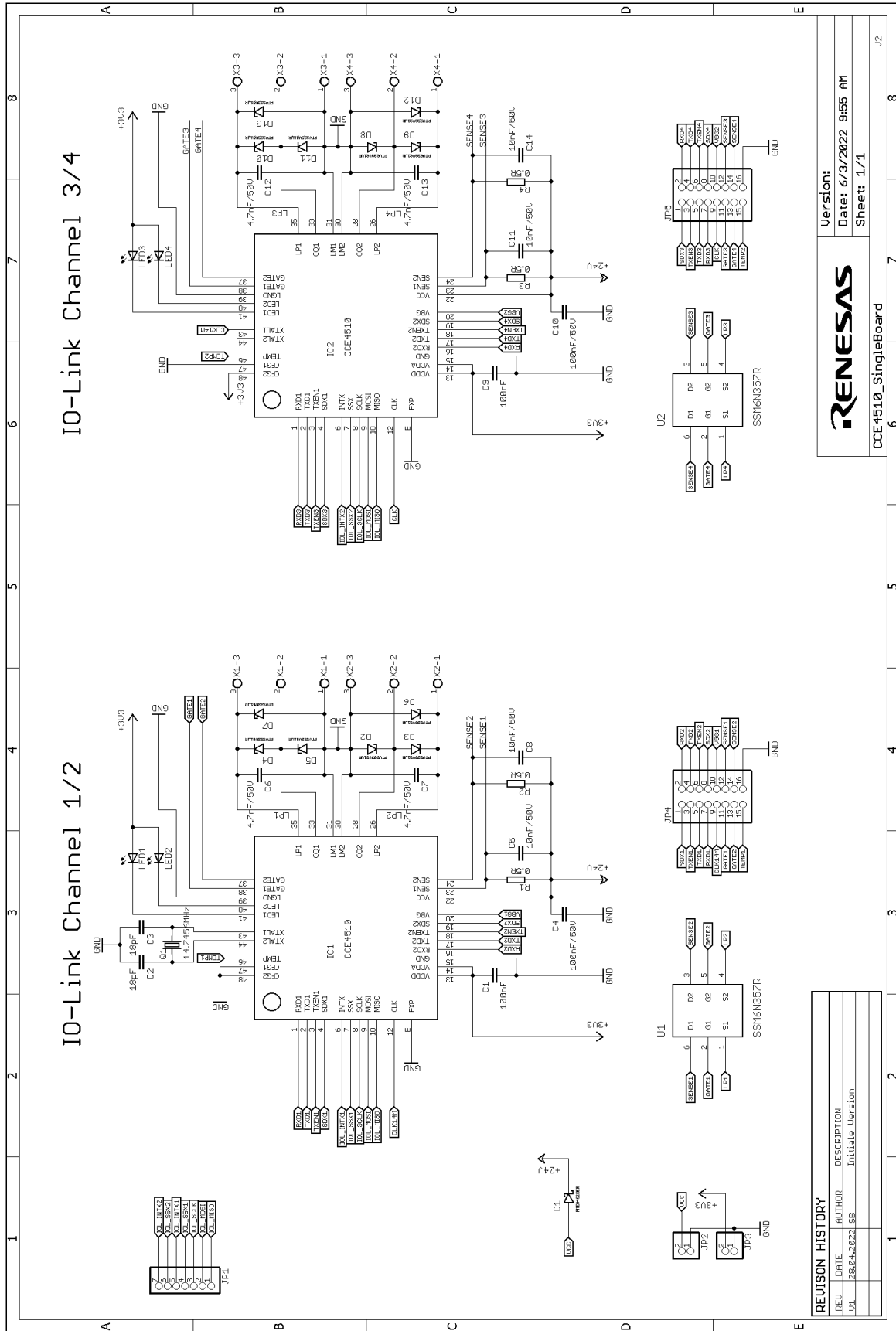

## 2.2 Bill of Materials

Qty	Reference Designator	Description	Manufacturer	Manufacturer Part Number
4	C1, C4, C9, C10	CAP, SMD, 0603, 100nF, 50V, 10%, X7R	Any	Any
2	C2, C3	CAP, SMD, 0603, 18pF, 50V, 5%, C0G/NP0,	Any	Any
4	C5, C8, C11, C14	CAP, SMD, 0603, 10nF, 50V, 10%, X7R	Any	Any
4	C6, C7, C12, C13	CAP, SMD, 0805, 4.7nF, 50V, 10%, X7R	Any	Any
1	D1	Diode Schottky 40 V 2A Surface Mount SOD-123FL	Panjit Semiconductor	SS2040FL_R1_00001
12	D2, D3, D4, D5, D6, D7, D8, D9, D10, D11, D12, D13	53.3V Clamp 7.5A Ipp TVS Diode Surface Mount SOD-123FL	Eaton	SMFE33ALH
2	IC1, IC2	IO-Link Master PHY	Renesas Electronics	CCE4510
1	JP1	7 pos. Pin Header 2.54mm	Any	Any
2	JP2, JP3	2 pos. Pin Header 2.54mm	Any	Any
2	JP4, JP5	16 pos. Pin Header 2.54mm	Any	Any
4	LED1, LED2, LED3, LED4	Orange 606nm LED Indication - Discrete 1.8V 0603 (1608 Metric)	Osram Opto	LO L29K-H2L1-24-0-2-R18-Z
1	Q1	14.7456 MHz $\pm$ 20ppm Crystal 18pF 120 Ohms 4-SMD, No Lead	Würth	830055293
4	R1, R2, R3, R4	RES, SMD, 0603, 0.5R, 100mW, 1%	Welwyn	LRCS0603-0R5FT5
2	U1, U2	Mosfet Array 2 N-Channel (Dual) 60V 650mA (Ta) 1.5W (Ta) Surface Mount 6-TSOP-F	Toshiba Semiconductor	SSM6N357R,LF
4	X1, X2, X3, X4	3 Position Wire to Board Terminal Block Horizontal (3.50mm)	Metz Connect	31059103

## 2.3 Board Layout

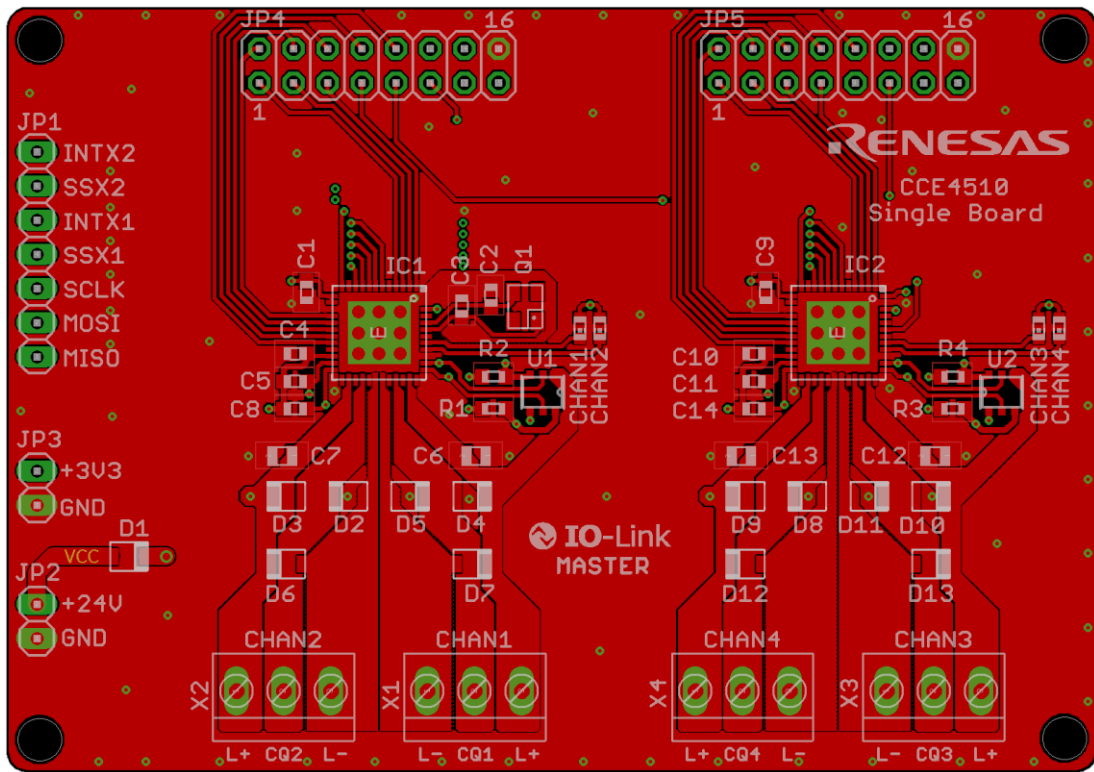

Figure 2. Top Layer

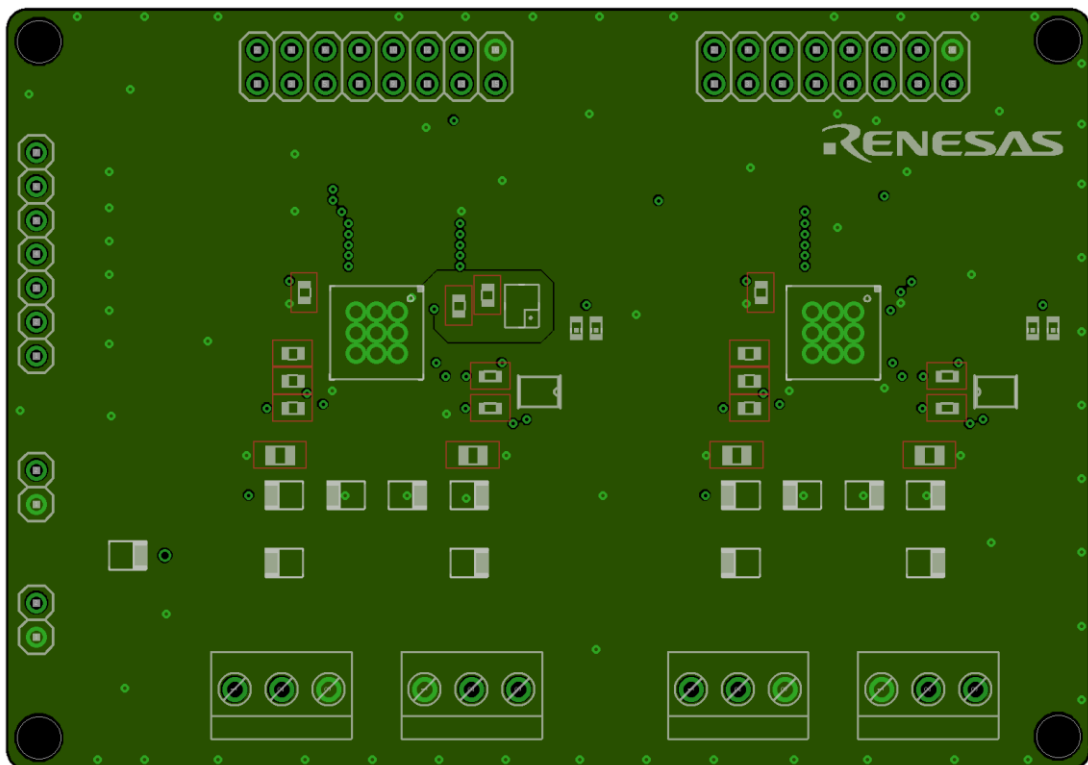

Figure 3. Second Layer (GND)

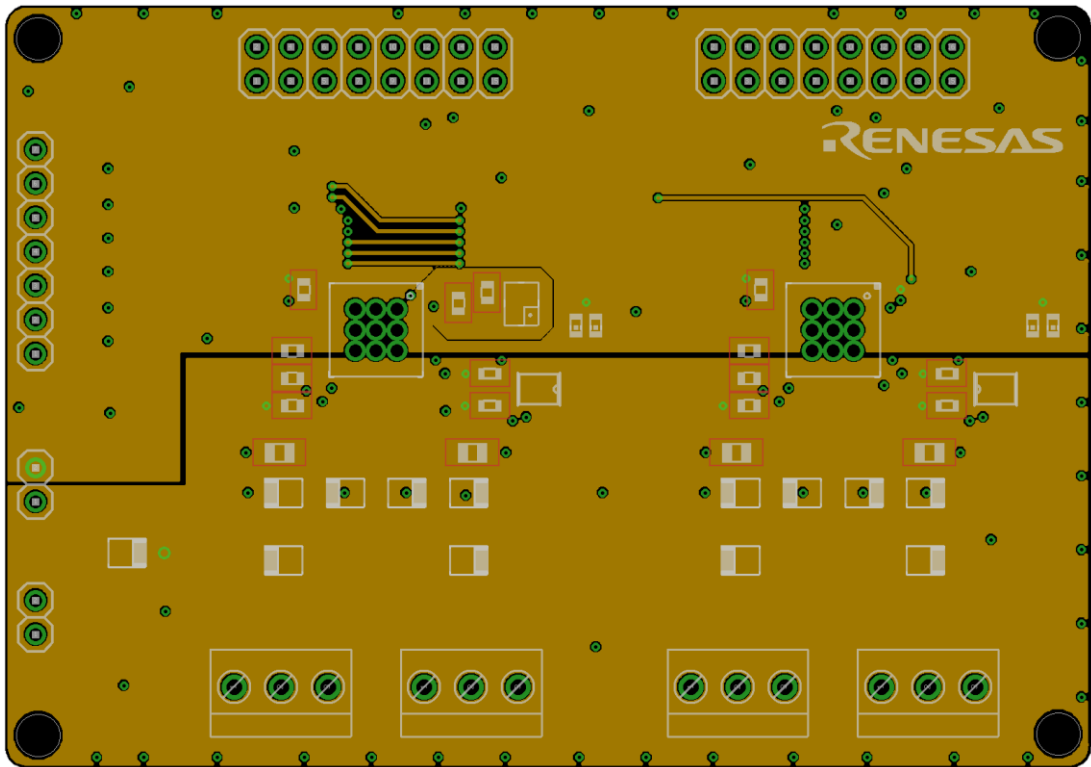

Figure 4. Third Layer (Supply)

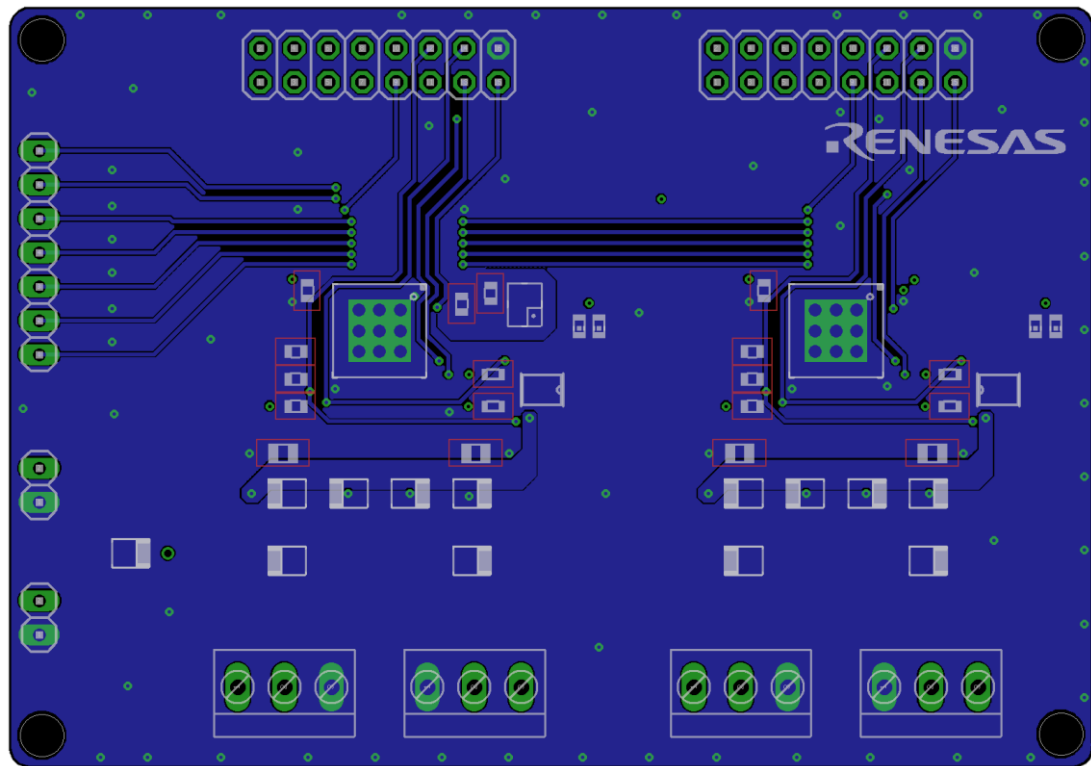

Figure 5. Bottom Layer

### 3. Ordering Information

Part Number	Description
CCE4510-SNGB-V1	CCE4510 Single Board V1

### 4. Revision History

Revision	Date	Description
1.00	Jun 7, 2022	Initial release.



## IMPORTANT NOTICE AND DISCLAIMER

RENESAS ELECTRONICS CORPORATION AND ITS SUBSIDIARIES (“RENESAS”) PROVIDES TECHNICAL SPECIFICATIONS AND RELIABILITY DATA (INCLUDING DATASHEETS), DESIGN RESOURCES (INCLUDING REFERENCE DESIGNS), APPLICATION OR OTHER DESIGN ADVICE, WEB TOOLS, SAFETY INFORMATION, AND OTHER RESOURCES “AS IS” AND WITH ALL FAULTS, AND DISCLAIMS ALL WARRANTIES, EXPRESS OR IMPLIED, INCLUDING, WITHOUT LIMITATION, ANY IMPLIED WARRANTIES OF MERCHANTABILITY, FITNESS FOR A PARTICULAR PURPOSE, OR NON-INFRINGEMENT OF THIRD-PARTY INTELLECTUAL PROPERTY RIGHTS.

These resources are intended for developers who are designing with Renesas products. You are solely responsible for (1) selecting the appropriate products for your application, (2) designing, validating, and testing your application, and (3) ensuring your application meets applicable standards, and any other safety, security, or other requirements. These resources are subject to change without notice. Renesas grants you permission to use these resources only to develop an application that uses Renesas products. Other reproduction or use of these resources is strictly prohibited. No license is granted to any other Renesas intellectual property or to any third-party intellectual property. Renesas disclaims responsibility for, and you will fully indemnify Renesas and its representatives against, any claims, damages, costs, losses, or liabilities arising from your use of these resources. Renesas' products are provided only subject to Renesas' Terms and Conditions of Sale or other applicable terms agreed to in writing. No use of any Renesas resources expands or otherwise alters any applicable warranties or warranty disclaimers for these products.

(Disclaimer Rev.1.01 Jan 2024)

### Corporate Headquarters

TOYOSU FORESIA, 3-2-24 Toyosu,  
Koto-ku, Tokyo 135-0061, Japan  
[www.renesas.com](http://www.renesas.com)

### Trademarks

Renesas and the Renesas logo are trademarks of Renesas Electronics Corporation. All trademarks and registered trademarks are the property of their respective owners.

### Contact Information

For further information on a product, technology, the most up-to-date version of a document, or your nearest sales office, please visit [www.renesas.com/contact-us/](http://www.renesas.com/contact-us/).