

Introduction

Choosing a crystal with the correct characteristics is one of the most critical steps in using a Voltage Controlled Crystal Oscillator (VCXO).

VCXO Crystal Selection

The crystal parameters affect the tuning range and accuracy of a VCXO. Below are the key variables and an example of using the crystal parameters to calculate the tuning range of the VCXO.

Figure 1. VCXO Oscillator Circuit

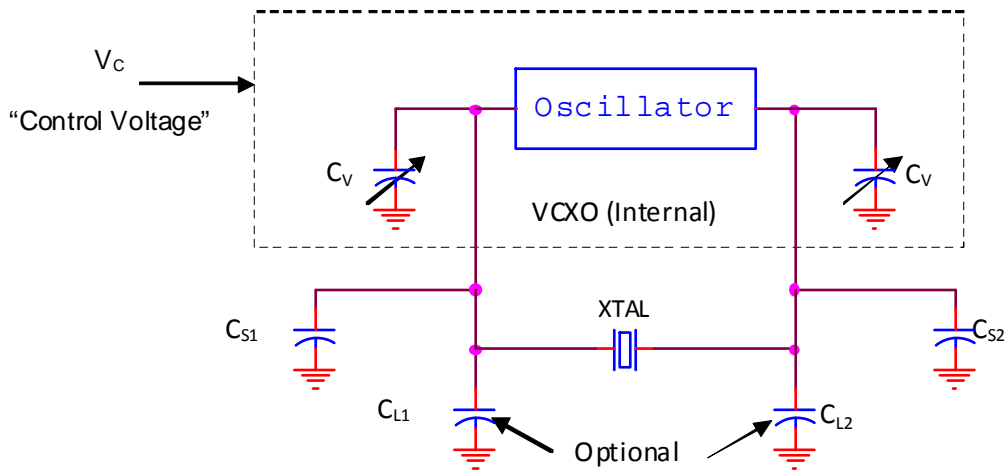

where

Vc = Control voltage used to tune frequency

Cv = Varactor capacitance, varies due to the change in voltage control

CL1/CL2 = Load tuning capacitance used for fine tuning or centering nominal frequency

Cs1/Cs2 = Stray Capacitance caused by pads, vias, and other board parasitics

Crystal Parameters Example

Symbol	Parameter	Test Conditions	Minimum	Typical	Maximum	Units
	Mode of Oscillation		Fundamental			
f_N	Frequency			25		MHz
f_T	Frequency Tolerance				±20	ppm
f_S	Frequency Stability				±20	ppm
	Operating Temperature Range		-40		85	°C
C_L	Load Capacitance			Note 1		pF
C_O	Shunt Capacitance			4		pF
C_O / C_1	Pullability Ratio			220	240	
F_{L_3OVT}	3 rd Overtone F_L		200			ppm
$F_{L_3OVT_spurs}$	3 rd Overtone F_L Spurs		200			ppm
ESR	Equivalent Series Resistance				20	Ω
	Drive Level				1	mW
	Aging @ 25 °C				±3 per year	ppm

Varactor Parameters

Symbol	Parameter	Typical	Unit
CVLOW	Low Varactor Capacitance	15.4 (note 1)	pF
CVHIGH	High Varactor Capacitance	29.6 (note 1)	pF

Note 1: Refer to the device datasheet for recommended CVLOW and CVHIGH.

Formulas

$$C_{Low} = \frac{(C_{L1} + C_{S1} + C_{V_Low}) \cdot (C_{L2} + C_{S2} + C_{V_Low})}{(C_{L1} + C_{S1} + C_{V_Low}) + (C_{L2} + C_{S2} + C_{V_Low})} \quad C_{High} = \frac{(C_{L1} + C_{S1} + C_{V_High}) \cdot (C_{L2} + C_{S2} + C_{V_High})}{(C_{L1} + C_{S1} + C_{V_High}) + (C_{L2} + C_{S2} + C_{V_High})}$$

- C_{Low} is the effective capacitance due to the low varactor capacitance, load capacitance and stray capacitance. C_{Low} determines the high frequency component on the TPR.
- C_{High} is the effective capacitance due to the high varactor capacitance, load capacitance and stray capacitance. C_{High} determines the low frequency component on the TPR.

$$Total\ Pull\ Range\ (TPR) = \left(\frac{1}{2 \cdot C_0 / C_1 \cdot \left(1 + \frac{C_{Low}}{C_0}\right)} - \frac{1}{2 \cdot C_0 / C_1 \cdot \left(1 + \frac{C_{High}}{C_0}\right)} \right) \cdot 10^6$$

$$AbsolutePullRange(APR) = TotalPullRange - (FrequencyTolerance + FrequencyStability + Aging)$$

Example Calculations

Using the tables and figures above, we can now calculate the TPR and APR of the VCXO using the example crystal parameters. For the numerical example below there were some assumptions made. First, the stray capacitance (C_{S1}, C_{S2}), which is all the excess capacitance due to board parasitic, is 4pF. Second, the expected lifetime of the project is 5 years; hence the inaccuracy due to aging is ±15ppm. Third, though many boards will not require load tuning capacitors (C_{L1}, C_{L2}), it is recommended for long-term consistent performance of the system that two tuning capacitor pads be placed into every design. Typical values for the load tuning capacitors will range from 0 to 4pF.

$$C_{Low} = \frac{(0 + 4\text{ pf} + 15.4\text{ pf}) \cdot (0 + 4\text{ pf} + 15.4\text{ pf})}{(0 + 4\text{ pf} + 15.4\text{ pf}) + (0 + 4\text{ pf} + 15.4\text{ pf})} = 9.7\text{ pf} \quad C_{High} = \frac{(0 + 4\text{ pf} + 29.6\text{ pf}) \cdot (0 + 4\text{ pf} + 29.6\text{ pf})}{(0 + 4\text{ pf} + 29.6\text{ pf}) + (0 + 4\text{ pf} + 29.6\text{ pf})} = 16.8\text{ pf}$$

$$TPR = \left(\frac{1}{2 \cdot 220 \cdot \left(1 + \frac{9.7\text{ pF}}{4\text{ pF}}\right)} - \frac{1}{2 \cdot 220 \cdot \left(1 + \frac{16.8\text{ pF}}{4\text{ pF}}\right)} \right) \cdot 10^6 = 226.5\text{ ppm}$$

$$TPR = \pm 113.25\text{ ppm}$$

$$APR = 113.25\text{ ppm} - (20\text{ ppm} + 20\text{ ppm} + 15\text{ ppm}) = \pm 58.25\text{ ppm}$$

The example above will ensure a total pull range of ±113.25 ppm with an APR of ±58.25ppm. Many times, board designers may select their own crystal based on their application. If the application requires a tighter APR, a crystal with better pull-ability (C₀/C₁ ratio) can be used. Also, with the equations above, one can vary the frequency tolerance, temperature stability, and aging or shunt capacitance to achieve the required pull-ability.

Recommended Vendors

Some of the Voltage controlled crystal oscillators devices from IDT require a pull-able crystal. There are VCXO's designed by IDT which do not require a pull-able crystal. The Crystal parameters for the VCXO's are in the datasheet. Most crystal manufactures, given the crystal specifications can manufacture a reliable crystal to work with IDT VCXO's. If there are any comments or concerns, please contact IDT.

IMPORTANT NOTICE AND DISCLAIMER

RENESAS ELECTRONICS CORPORATION AND ITS SUBSIDIARIES (“RENESAS”) PROVIDES TECHNICAL SPECIFICATIONS AND RELIABILITY DATA (INCLUDING DATASHEETS), DESIGN RESOURCES (INCLUDING REFERENCE DESIGNS), APPLICATION OR OTHER DESIGN ADVICE, WEB TOOLS, SAFETY INFORMATION, AND OTHER RESOURCES “AS IS” AND WITH ALL FAULTS, AND DISCLAIMS ALL WARRANTIES, EXPRESS OR IMPLIED, INCLUDING, WITHOUT LIMITATION, ANY IMPLIED WARRANTIES OF MERCHANTABILITY, FITNESS FOR A PARTICULAR PURPOSE, OR NON-INFRINGEMENT OF THIRD-PARTY INTELLECTUAL PROPERTY RIGHTS.

These resources are intended for developers who are designing with Renesas products. You are solely responsible for (1) selecting the appropriate products for your application, (2) designing, validating, and testing your application, and (3) ensuring your application meets applicable standards, and any other safety, security, or other requirements. These resources are subject to change without notice. Renesas grants you permission to use these resources only to develop an application that uses Renesas products. Other reproduction or use of these resources is strictly prohibited. No license is granted to any other Renesas intellectual property or to any third-party intellectual property. Renesas disclaims responsibility for, and you will fully indemnify Renesas and its representatives against, any claims, damages, costs, losses, or liabilities arising from your use of these resources. Renesas' products are provided only subject to Renesas' Terms and Conditions of Sale or other applicable terms agreed to in writing. No use of any Renesas resources expands or otherwise alters any applicable warranties or warranty disclaimers for these products.

(Disclaimer Rev.1.01 Jan 2024)

Corporate Headquarters

TOYOSU FORESIA, 3-2-24 Toyosu,
Koto-ku, Tokyo 135-0061, Japan
www.renesas.com

Trademarks

Renesas and the Renesas logo are trademarks of Renesas Electronics Corporation. All trademarks and registered trademarks are the property of their respective owners.

Contact Information

For further information on a product, technology, the most up-to-date version of a document, or your nearest sales office, please visit www.renesas.com/contact-us/.