

**Variable Pulse Width Variable Frequency Pulse Generator**

This application uses the "B" driver of the EL7972 as an oscillator to drive the "A" driver. The frequency is set using R1 and C1. The pulse width is set by adjusting R2. Capacitors C2, C3 and C4 are decoupling capacitors. A fixed pulse width output is available at pin 5 while the variable pulse width signal is available at pin 7. For these particular component values a maximum pulse width of 2µs is available at pin 7.

The frequency is approximated by the relation:

$$f(\text{Hz}) = (1.5) V_{DD}(R1) (C1)$$

The pulse width is approximated by the relation:

$$T_{\text{width}} (\text{S}) = (4.5 \times 10^{-6}) 1 - R2500KV_{DD} - 100\text{ns}$$

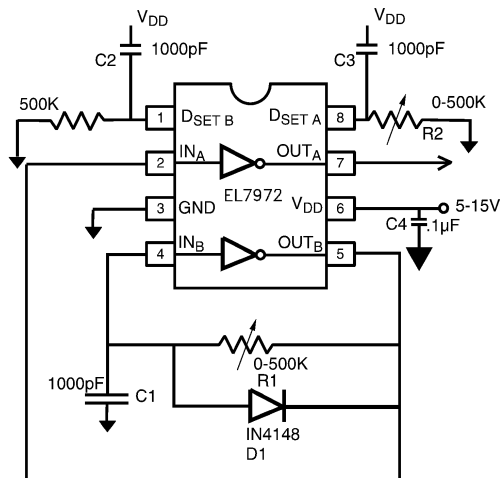

**100V DC Stable High Switch**

This application uses an EL7761 to drive the gate of an NMOS FET above the FET's source and drain voltage. This circuit would be useful in applications where the load must be energized continuously as in an automobile headlight circuit or a high side switch to a 48V bus in a distributed power application.

The low side driver self oscillates at a frequency determined by its input hysteresis in conjunction with R2 and C3. The output of the oscillator (pins 10 and 11) drive a charge pump which powers the high side drive section of the EL7761. A low voltage at the EN pin shuts the drive to the external FET off as well as shutting down the charge pump oscillator and putting the chip into a low supply current mode. Capacitors C1 and C4 are used to decouple the supplies. V<sub>DD</sub> must be at least a diode drop higher than the desired enhancement of the external FET. The reverse breakdown of the zener diode should be less than 15V in order to avoid an overvoltage of the high side driver. Depending on the exact nature of the circuit a zener diode is not always necessary.

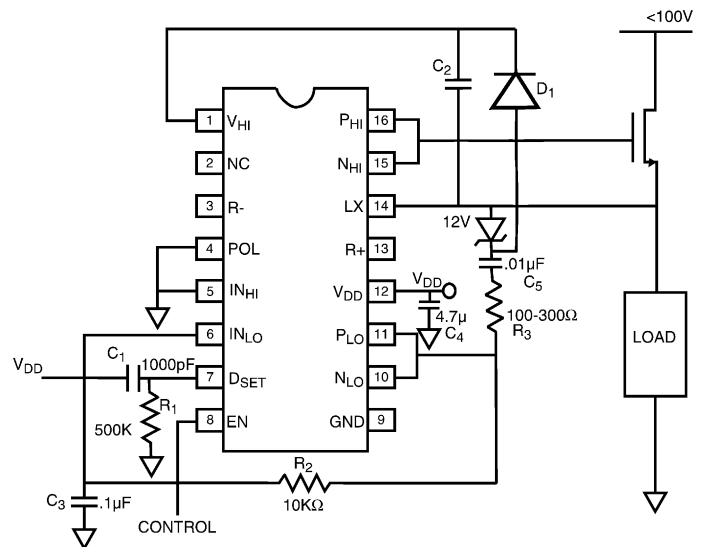

- C<sub>1</sub> - 1000pF ceramic
- C<sub>2</sub> - .1µF ceramic
- C<sub>3</sub> - .1µF ceramic
- C<sub>4</sub> - 1-4.7µF Tant.
- C<sub>5</sub> - .01µF ceramic 100V
- D<sub>1</sub>, D<sub>2</sub> - IN4148
- R<sub>1</sub> - 500KΩ 1/4w
- R<sub>2</sub> - 10KΩ 1/4w
- R<sub>3</sub> - 100Ω - 300Ω 1/4w

100V, Single chip, DC stable high side switch

### Synchronous Buck Regulator Driver

In this application one driver of the EL7981 is used to drive the main switch of a buck regulator while the other driver drives the synchronous switch. A transformer is used to obtain the high side switching voltage for M1. R1 sets the dead time delay between the on times of M1 and M2. The adjustable delay is perfect for devices with long turn off times such as IGBT's.

### Buck Regulator High Side Drive Using the EL7501

These circuits show two ways of using the EL7501 to drive the high side switch in a buck converter application. The first method uses resistors R1 and R2 to bias pin 1 in the middle of the drive voltage swing at pin 4. This allows the use of a single sided PWM drive. The high side voltage is pumped up from the  $V_{DD}$  supply.

The second method uses a complementary drive signal at pins 1 and 4 of the EL7501. It derives its high side supply voltage by charging capacitor C1 through resistor R1 and then using the external FET to pump that voltage above the high side supply.

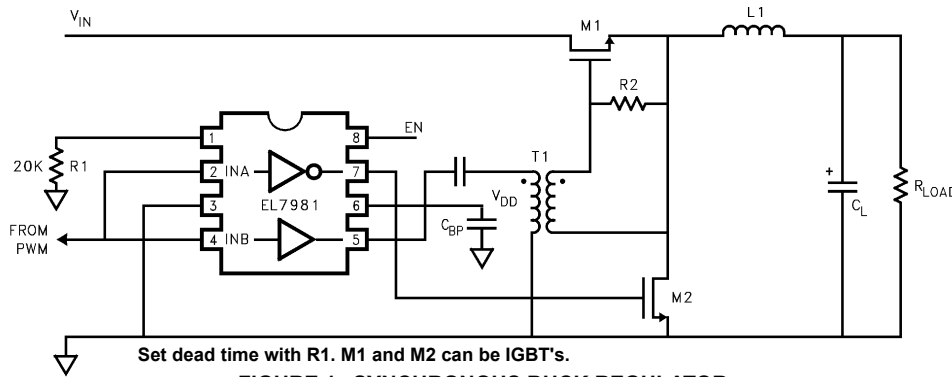

FIGURE 1. SYNCHRONOUS BUCK REGULATOR

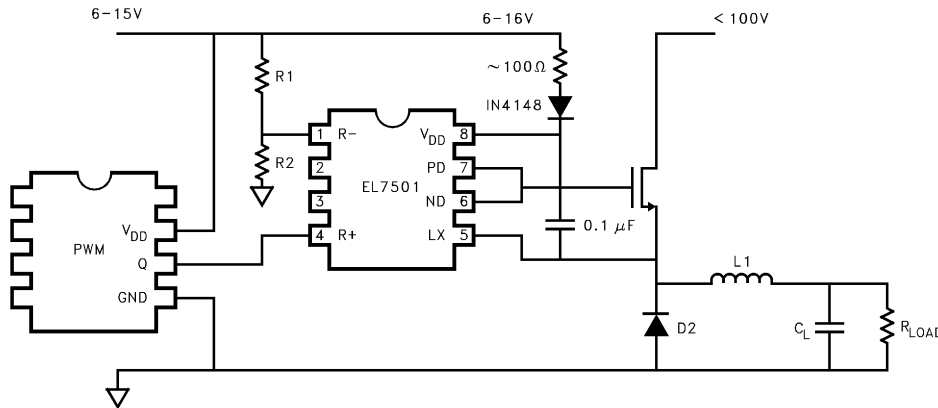

FIGURE 2A. EL7501 BUCK REGULATOR WITH HIGH SIDE DRIVE - FIRST METHOD

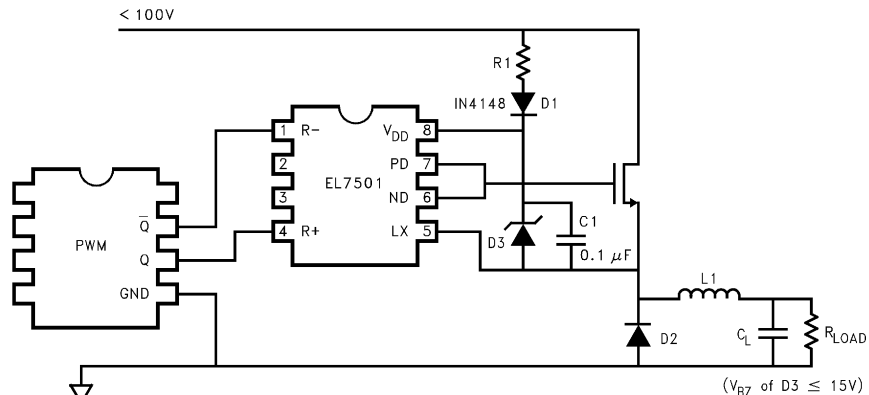

FIGURE 2B. EL7501 BUCK REGULATOR WITH HIGH SIDE DRIVE (ALTERNATE BIASING SCHEME) - SECOND METHOD

### Self Powered DC Stable 100V Half Bridge Driver

This circuit uses one driver of an EL7972 to provide low side drive and the other driver as a charge pump oscillator. The output of the charge pump oscillator drives a capacitor diode network to provide high side supply voltage to the EL7501. The EL7501 drives a high side external N-FET. Due to the addition of the charge pump this circuit will work at any driving frequency from DC to >1MHz.

### IGBT Half Bridge Driver

This circuit shows the EL7981 being used to drive an IGBT half bridge. The high side IGBT is transformer coupled to the driver.

The value of R1 is chosen so that the two IGBT's never conduct at the same time. If the IGBT's have different turn off characteristics then the EL7982 could be used instead of the EL7981. The EL7982 has independent control of each of its driver's rising edge delay.

### Self Oscillating IGBT Driver

This circuit self oscillates at approximately 25kHz. The on times of each driver depend on the values of R1, C1, R2 and C2. In order to ensure equal on times accurate component values may need to be used. The resistor, R3, controls the dead time between the on times of both drivers.

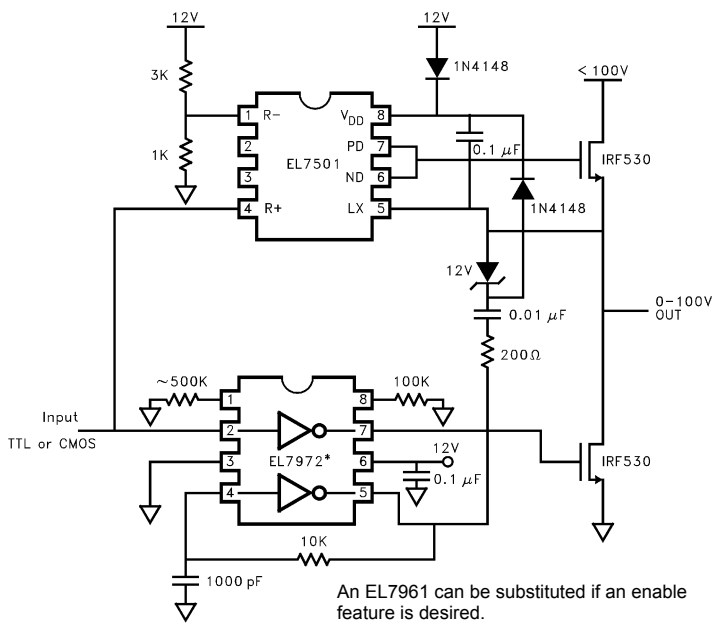

FIGURE 3. DC FUNCTIONAL HALF BRIDGE DRIVER

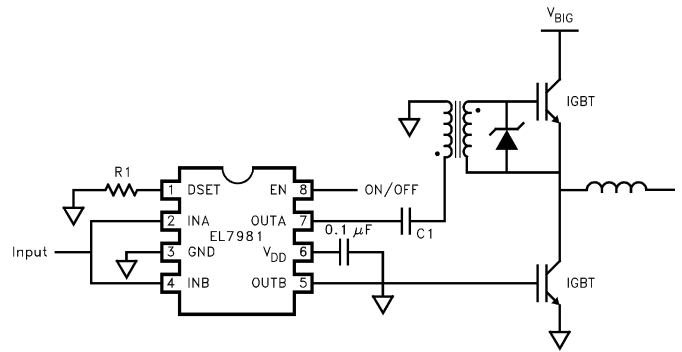

FIGURE 4. IGBT HALF BRIDGE DRIVER

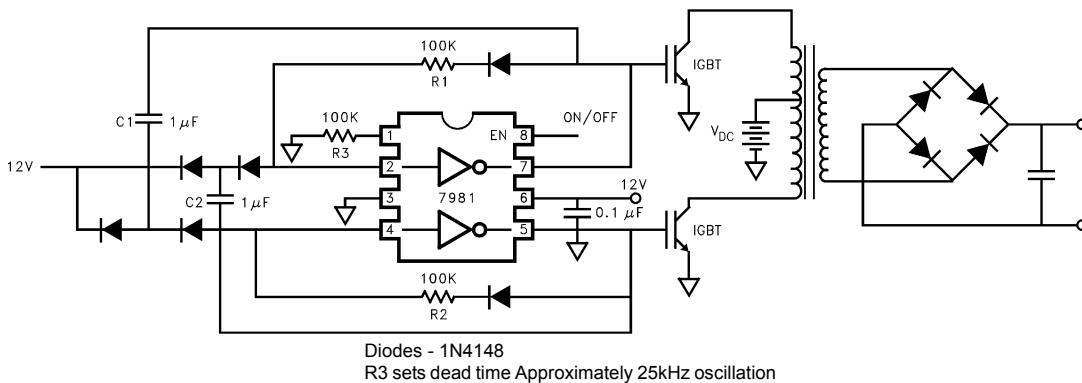

FIGURE 5. SELF OSCILLATING IGBT DRIVER, DC-DC STEP UP (OR DOWN)

### 40 Watt-12V Step Down Regulator Using a Synchronous Switch

This circuit shows how the EL7761 could be used as a half bridge driver for a step down converter. The circuit switches at 250kHz.

#### Simple Undervoltage Lockout Circuit

By using a zener diode and a pull down resistor the user can implement a simple UVLO circuit. As  $V_{DD}$  increases above the

zener voltage the EN pin rises above ground. When EN reaches  $V_{ton}$  the chip is enabled. As  $V_{DD}$  is lowered such that the voltage at EN falls below  $V_{toff}$ , the chip is disabled. The threshold tolerances are as follows:

- $1.0V < V_{ton} < 1.6V$
- $0.3V < V_{ton} - V_{toff} < 1.0V$
- $V_{turn-on} = V_Z + V_{ton}$
- $V_{turn-off} = V_Z + V_{toff}$

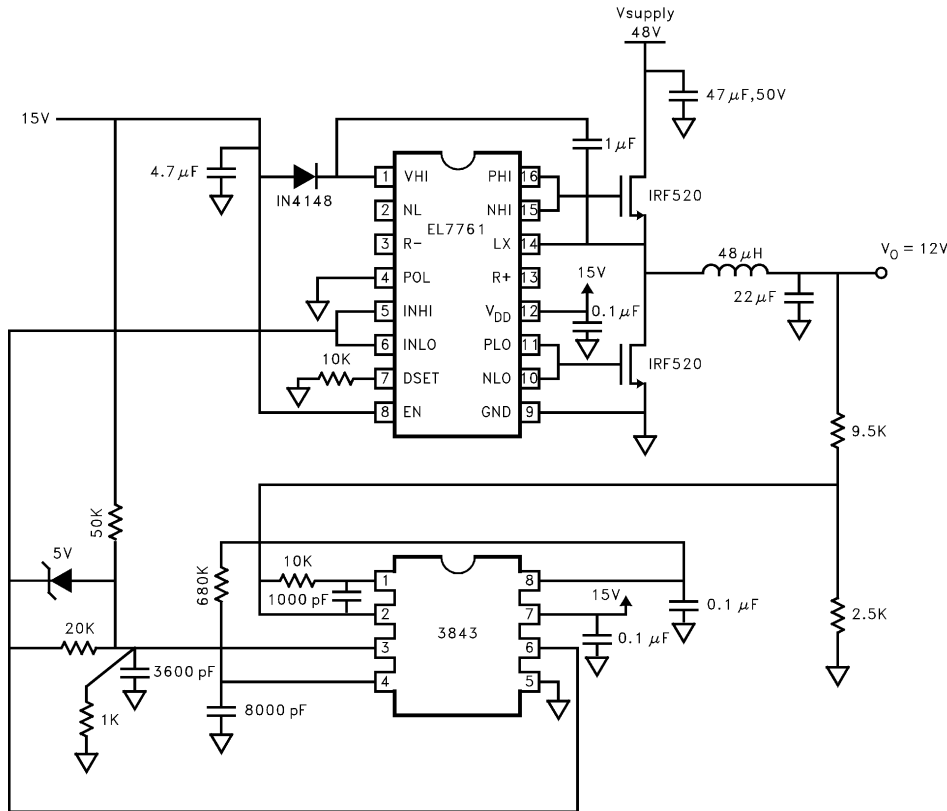

FIGURE 6. 12V STEP DOWN SYNCHRONOUS SWITCHES

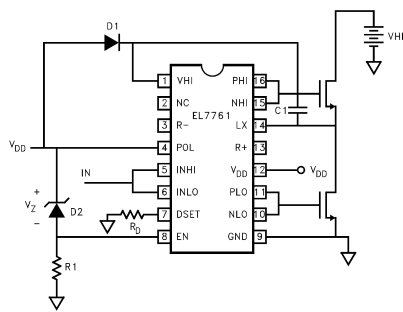
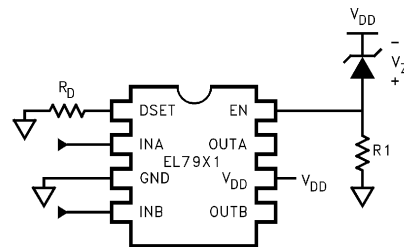

FIGURE 7. SIMPLE UVLO CIRCUIT FOR THE EL7761



$$V_{turn-on} = V_Z + V_{ton}$$

$$V_{turn-off} = V_Z + V_{toff}$$

FIGURE 8. SIMPLE UVLO CIRCUIT FOR THE EL79X1

### Video Sync Pulse Generator

The EL7501 inputs function outside the power supply rails, allowing a ground referenced TTL signal to control a ground to -8V output swing. The output resistors can be adjusted to tailor the rise and fall times of the circuit.

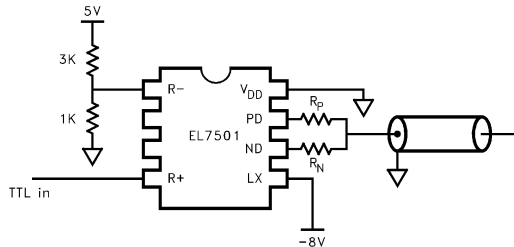

### Synchronous Switch Increases Boost Efficiency

The EL7501 plus a N-FET replaces the catch diode in a boost regulator. When the R+ pin is higher than the R- pin, the FET is turned on, effectively shorting out the parasitic diode of the FET. A small resistor may be added in series with the R- pin in order to “tune” the turn-on delay of the FET.

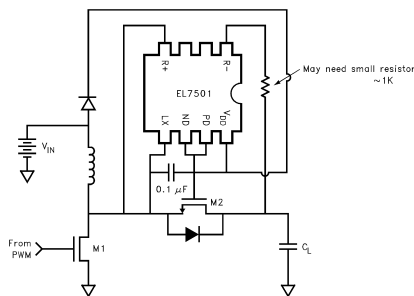

### Resonant Gate Driver

Resonant gate driver can be used to boost the gate voltage swing while increasing driver efficiency. In Figure 9, an EL7501 is configured with (2) external “ring” diodes and resonating inductor  $L_R$ . For tutorial purposes, the power MOSFET load was replaced by a 1000pF capacitor ( $C_L$ ). The “ring” diodes are fast switching diodes capable of withstanding the 1 amp peak current, such as the 1N914. Standard de-coupling techniques are applied with 5V applied to  $V_{DD}$ , the circuit delivers +10V to -5V output. In “5V only” systems, sufficient output swing is available so as to eliminate the need for costly “logic level” power FETs, and provides below ground swing for superior turn-off.

### Principle of Operation

When the input drops below 2.4V, pin 7 pulls high, allowing current to flow from  $V_{DD}$  thru D1 and  $L_R$ , thus charging  $C_L$ . Initially the full voltage appears across the inductor, but as the current starts to flow,  $C_L$  begins to charge. When  $C_L$  reaches the supply voltage, current continues to flow as the inductor  $L_R$  reverses direction and continues to charge the capacitor beyond the supply voltage. When  $C_L$  reaches it's peak, the “ring” diode disconnects, holding that potential across  $C_L$ . The peak voltage can be controlled by adjusting the circuit “Q”. Typically this is accomplished by varying the size of inductor  $L_R$ , since the “on” resistance of the driver can limit the circuit “Q”. This is governed by the expression:

$$Q = \omega LR$$

$$\text{where: } \omega = 1/LC \text{ or } Q = 1/R LC$$

Thus, higher “Q”, and higher voltage swing can be maintained by making L/C large compared to R. (R = 5Ω typ. for the EL7501.)

Similarly, when pin-6 pulls low, the output resonates below ground to provide good turn-off. Since charge is transferred mostly thru the inductor, rather than a resistor efficiency is much higher. The circuit performance is summarized below.

TABLE 1. CONDITIONS:  $V_{DD} = 5V$ ,  $f_C = 220kHz$

(L) INDUCTANCE	$V_{OUT (+)}$	$V_{OUT -}$	$T_R/T_F$	
Case 1	1μH	7V	-2.1V	60ns
Case 2	47μH	18V	-12V	300ns

The power consumption was measured for Case 2, at 40mW. Using “resistive” charging a power dissipation/consumption of 200mW is anticipated, thus resulting in a (5) fold improvement in efficiency.

$$UV = (1.5) R_1 + R_2R_1$$

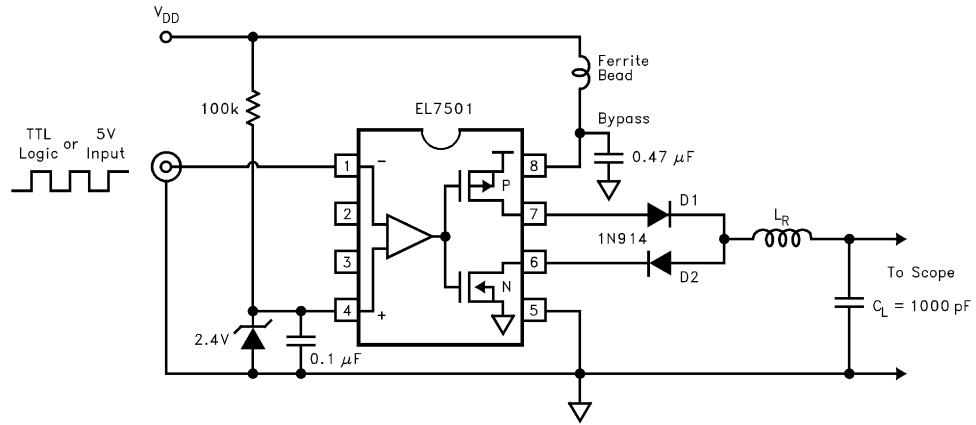

FIGURE 9. RESONANT GATE DRIVER

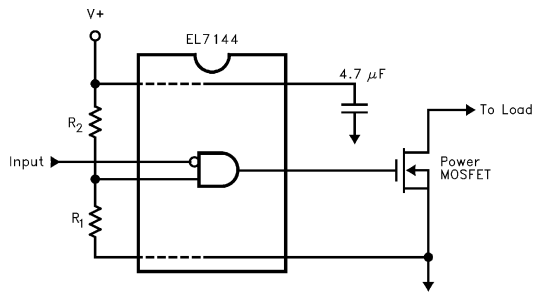

FIGURE 10. MOS DRIVER WITH UNDER-VOLTAGE LOCK-OUT

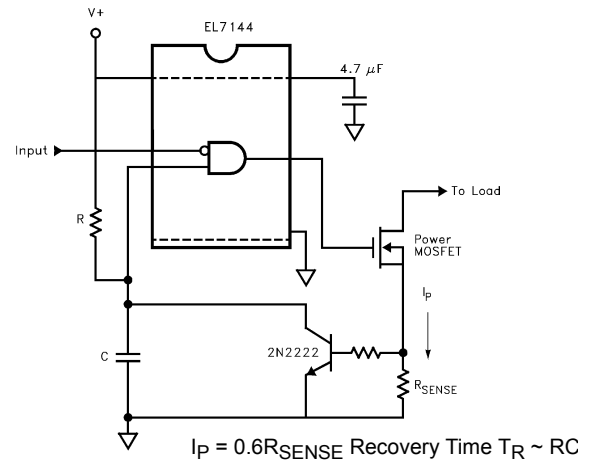

FIGURE 11. OVER-CURRENT PROTECTED DRIVER

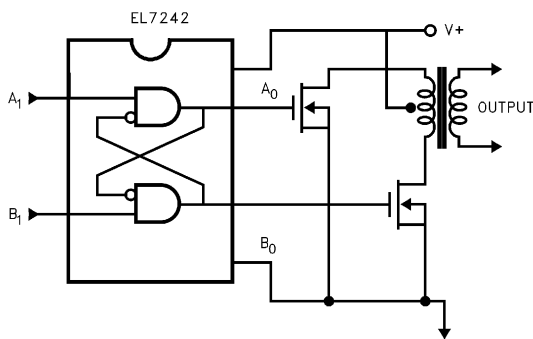

FIGURE 12. MOS DRIVER WITH SIMULTANEOUS CONDUCTION LOCK-OUT

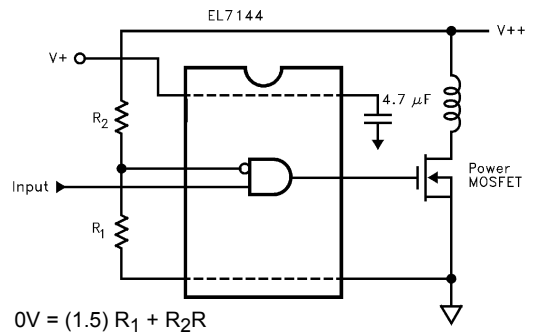

FIGURE 13. MOS DRIVER WITH OVER-VOLTAGE PROTECTION

TABLE 2. TRUTH TABLE

A <sub>1</sub>	B <sub>1</sub>	A <sub>0</sub>	B <sub>0</sub>
0	0	0	0
0	1	0	1
1	0	1	0
1	0	1/0	0/1

## MOSFET Driver Generates its Own +12V Supply

When you want to drive one power MOSFET, from a 5V or a 3.3V system, generating the one extra +12V supply can involve quite a large number of both active and passive components.

Here is a solution that uses the spare second MOSFET Driver channel to derive its own +12V supply. By using a driver with the drains brought out to separated pins, one can connect an inductor between the N-channel drain and the logic supply, without having the P-channel device connected.

In operation, it works as a standard flyback style switched mode circuit. When the output N-channel device is on, current starts flowing in the inductor, storing energy. When the N-channel device is turned off, the current has to continue flowing, so it flows through the diode D2 to charge up capacitors C1 and C2. As the cycle repeats, the voltage on C1 and C2 rises until the zener diode prevents further voltage rise. This is needed to prevent the drivers' derived supply from exceeding the parts' maximum voltage rating.

Since the objective was to minimize the number of external components and cost, additional components which would allow the circuit to self oscillate and regulate were omitted. The logic system was able to supply a drive pulse waveform to the supply generator. With the 5V system, I was using a 1.5 $\mu$ s pulse every 9 $\mu$ s. This gave a very solid +12.4V, and the system supply current went up by about 11mA. The 3.3V system used a 300kHz square wave, for a similar 12V derived supply, but with nearly 40mA extra supply current. In both systems, when the MOSFET Driver was not being used, it could be "powered down" by simply stopping the pulses to the switching channel.

Any dual MOSFET Driver can be used, but if the drains of the output stage are not separated, there may be some protection and other parasitic devices that may prevent satisfactory operation. In these cases an external fet can be used to drive the inductor, provided a low threshold device is used. By altering the inductor value and the controlling pulses, enough power can be derived for further MOSFET Drivers or other peripheral devices requiring +12V.

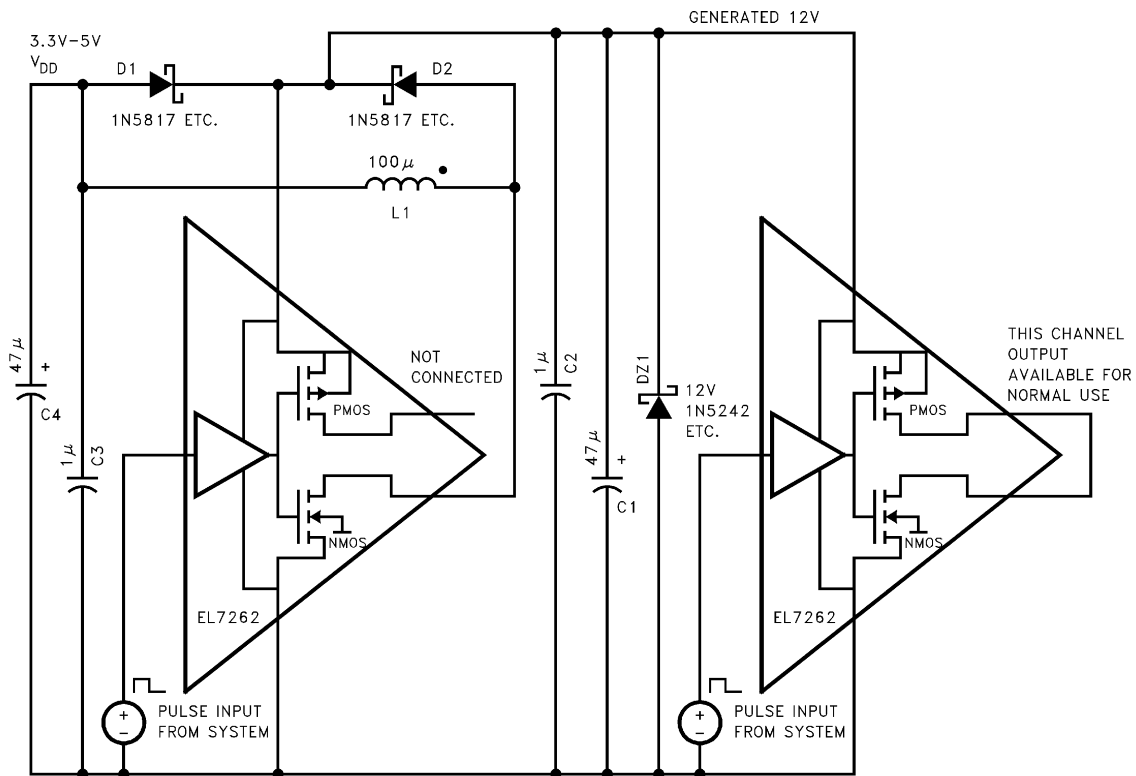

FIGURE 14. SELF CHARGE PUMPING MOSFET DRIVER

## Super Inverters

CMOS is often equated with low power, however dynamic losses can be significant, particularly as the frequency of operation increases. Losses can be attributed to the parasitic capacitance on all internal nodes which toggle (described by  $P = CV2f$ ), and from simultaneous conduction through CMOS gates during switching. Parasitic capacitance is reduced by shrinking feature sizes and using low overlap, self aligned silicon-gate process technology. Simultaneous conduction (shoot-thru) can be controlled or eliminated completely with "super-inverter" technology. A standard CMOS inverter is shown in Figure 15A. Here, with every transition, there is an interval during which both the NMOS and PMOS transistors are conducting and dissipating energy.

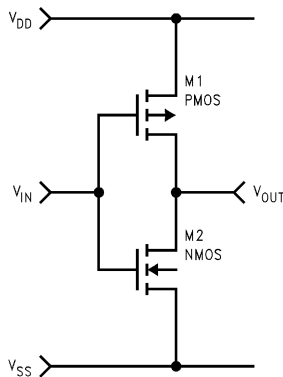

FIGURE 15A. STANDARD CMOS INVERTER

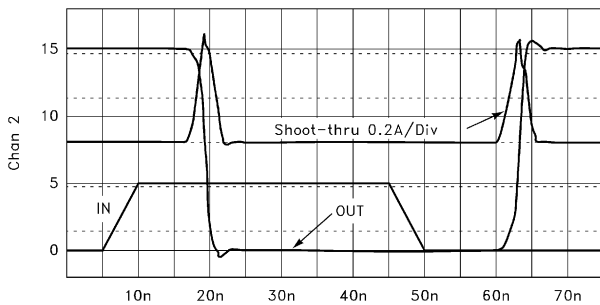

FIGURE 15B. CMOS INVERTER SWITCHING LOSSES

Thus the integral of the instantaneous shoot-thru current, multiplied by the supply voltage and clock frequency describes the power loss.

$$P = 2fV_{DD} \int I_{shoot}(t) dt$$

These losses can be significant, and are illustrated in Figure 15B. The super-inverter shown in Figure 16A overcomes the "shoot-thru" problem with "break before make" asymmetric drive, thereby controlling or eliminating simultaneous conduction. The designer can trade-off shoot-thru current for added propagation delay. The results demonstrated in Figure 16B represent about a 4x improvement. An added benefit is the reduced power supply bounce resulting from di/dt and stray inductance.

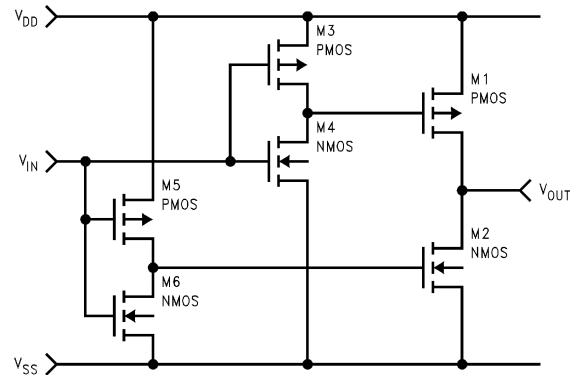

FIGURE 16A. SUPER INVERTER

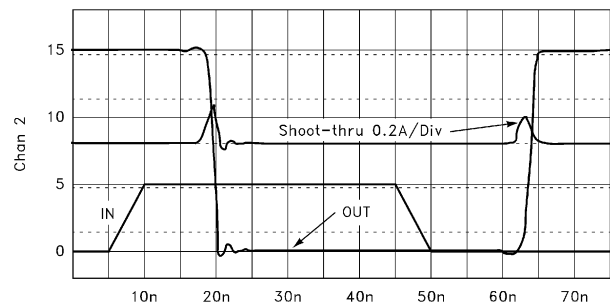

FIGURE 16B. SUPER INVERTER SWITCHING LOSSES

## Input Source Follower

To accommodate moderately high source impedances, a source follower input stage similar to the circuit shown in Figure 17 is used. This eliminates both the "Miller" gate capacitance, and gate to source capacitance seen in typical designs. The "boot-strapping" effect eliminates all but the gate-drain capacitance. This feature allows direct drive from low current logic, without any degradation in performance.

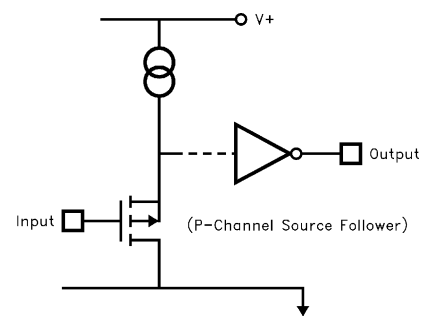

FIGURE 17. LOW INPUT CAPACITANCE SOURCE FOLLOWER

## Precision Level Shifting

Generating rail to rail drive from a logic level input is accomplished with a Class AB push-pull amplifier and an internal 1.2V reference. This produces a well controlled threshold with minimal propagation delay. The known switch point can be used to generate under-voltage lock-out protection. Hysteresis is also introduced to boost the noise immunity.



### 3-State and Gated Inputs

Additional logic functions are also provided to insure greater flexibility. 3-State control is often useful in "Bridge" and "Bus" applications. Gated inputs can be used for chip enable/shut-down, latching, and various other functions.

### Overall Performance

The resulting CMOS Drivers offer both functionality and performance. Figure 18 shows the switching characteristics into a 1000pF load. Rise time, fall time, and delay are all matched to minimize pulse distortion, and are less than 20ns. Figure 19 illustrates the waveform integrity at 5MHz, into 1000pF.

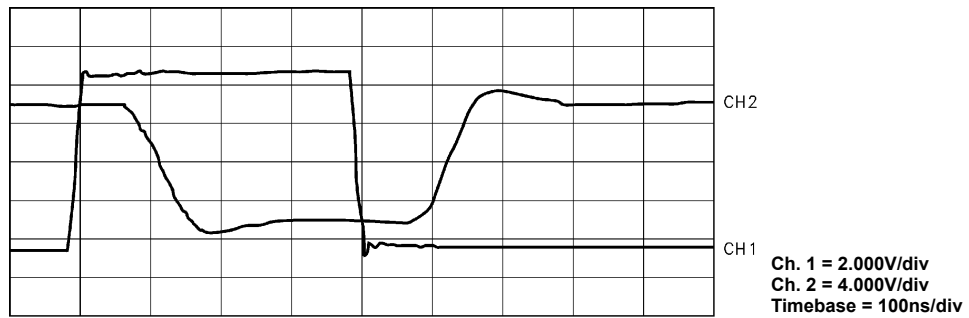

FIGURE 18. STEP RESPONSE INTO 1000pF LOAD

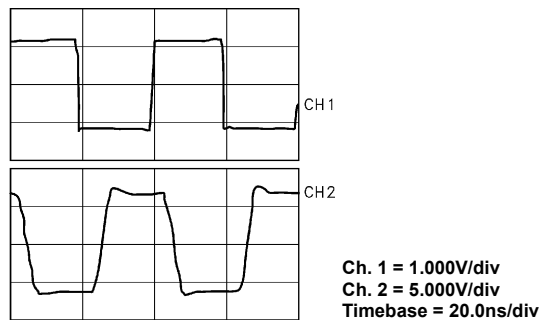

FIGURE 19. 5MHz OUTPUT INTO 1000pF LOAD

## Notice

1. Descriptions of circuits, software and other related information in this document are provided only to illustrate the operation of semiconductor products and application examples. You are fully responsible for the incorporation or any other use of the circuits, software, and information in the design of your product or system. Renesas Electronics disclaims any and all liability for any losses and damages incurred by you or third parties arising from the use of these circuits, software, or information.
  2. Renesas Electronics hereby expressly disclaims any warranties against and liability for infringement or any other claims involving patents, copyrights, or other intellectual property rights of third parties, by or arising from the use of Renesas Electronics products or technical information described in this document, including but not limited to, the product data, drawings, charts, programs, algorithms, and application examples.
  3. No license, express, implied or otherwise, is granted hereby under any patents, copyrights or other intellectual property rights of Renesas Electronics or others.
  4. You shall not alter, modify, copy, or reverse engineer any Renesas Electronics product, whether in whole or in part. Renesas Electronics disclaims any and all liability for any losses or damages incurred by you or third parties arising from such alteration, modification, copying or reverse engineering.
  5. Renesas Electronics products are classified according to the following two quality grades: "Standard" and "High Quality". The intended applications for each Renesas Electronics product depends on the product's quality grade, as indicated below.  
"Standard": Computers; office equipment; communications equipment; test and measurement equipment; audio and visual equipment; home electronic appliances; machine tools; personal electronic equipment; industrial robots; etc.  
"High Quality": Transportation equipment (automobiles, trains, ships, etc.); traffic control (traffic lights); large-scale communication equipment; key financial terminal systems; safety control equipment; etc.  
Unless expressly designated as a high reliability product or a product for harsh environments in a Renesas Electronics data sheet or other Renesas Electronics document, Renesas Electronics products are not intended or authorized for use in products or systems that may pose a direct threat to human life or bodily injury (artificial life support devices or systems; surgical implantations; etc.), or may cause serious property damage (space system; undersea repeaters; nuclear power control systems; aircraft control systems; key plant systems; military equipment; etc.). Renesas Electronics disclaims any and all liability for any damages or losses incurred by you or any third parties arising from the use of any Renesas Electronics product that is inconsistent with any Renesas Electronics data sheet, user's manual or other Renesas Electronics document.
  6. When using Renesas Electronics products, refer to the latest product information (data sheets, user's manuals, application notes, "General Notes for Handling and Using Semiconductor Devices" in the reliability handbook, etc.), and ensure that usage conditions are within the ranges specified by Renesas Electronics with respect to maximum ratings, operating power supply voltage range, heat dissipation characteristics, installation, etc. Renesas Electronics disclaims any and all liability for any malfunctions, failure or accident arising out of the use of Renesas Electronics products outside of such specified ranges.
  7. Although Renesas Electronics endeavors to improve the quality and reliability of Renesas Electronics products, semiconductor products have specific characteristics, such as the occurrence of failure at a certain rate and malfunctions under certain use conditions. Unless designated as a high reliability product or a product for harsh environments in a Renesas Electronics data sheet or other Renesas Electronics document, Renesas Electronics products are not subject to radiation resistance design. You are responsible for implementing safety measures to guard against the possibility of bodily injury, injury or damage caused by fire, and/or danger to the public in the event of a failure or malfunction of Renesas Electronics products, such as safety design for hardware and software, including but not limited to redundancy, fire control and malfunction prevention, appropriate treatment for aging degradation or any other appropriate measures. Because the evaluation of microcomputer software alone is very difficult and impractical, you are responsible for evaluating the safety of the final products or systems manufactured by you.
  8. Please contact a Renesas Electronics sales office for details as to environmental matters such as the environmental compatibility of each Renesas Electronics product. You are responsible for carefully and sufficiently investigating applicable laws and regulations that regulate the inclusion or use of controlled substances, including without limitation, the EU RoHS Directive, and using Renesas Electronics products in compliance with all these applicable laws and regulations. Renesas Electronics disclaims any and all liability for damages or losses occurring as a result of your noncompliance with applicable laws and regulations.
  9. Renesas Electronics products and technologies shall not be used for or incorporated into any products or systems whose manufacture, use, or sale is prohibited under any applicable domestic or foreign laws or regulations. You shall comply with any applicable export control laws and regulations promulgated and administered by the governments of any countries asserting jurisdiction over the parties or transactions.
  10. It is the responsibility of the buyer or distributor of Renesas Electronics products, or any other party who distributes, disposes of, or otherwise sells or transfers the product to a third party, to notify such third party in advance of the contents and conditions set forth in this document.
  11. This document shall not be reprinted, reproduced or duplicated in any form, in whole or in part, without prior written consent of Renesas Electronics.
  12. Please contact a Renesas Electronics sales office if you have any questions regarding the information contained in this document or Renesas Electronics products.
- (Note 1) "Renesas Electronics" as used in this document means Renesas Electronics Corporation and also includes its directly or indirectly controlled subsidiaries.  
(Note 2) "Renesas Electronics product(s)" means any product developed or manufactured by or for Renesas Electronics.

(Rev.4.0-1 November 2017)



### SALES OFFICES

Renesas Electronics Corporation

<http://www.renesas.com>

Refer to "<http://www.renesas.com/>" for the latest and detailed information.

**Renesas Electronics America Inc.**  
1001 Murphy Ranch Road, Milpitas, CA 95035, U.S.A.  
Tel: +1-408-432-8888, Fax: +1-408-434-5351

**Renesas Electronics Canada Limited**  
9251 Yonge Street, Suite 8309 Richmond Hill, Ontario Canada L4C 9T3  
Tel: +1-905-237-2004

**Renesas Electronics Europe Limited**  
Dukes Meadow, Millboard Road, Bourne End, Buckinghamshire, SL8 5FH, U.K  
Tel: +44-1628-651-700, Fax: +44-1628-651-804

**Renesas Electronics Europe GmbH**  
Arcadiastrasse 10, 40472 Düsseldorf, Germany  
Tel: +49-211-6503-0, Fax: +49-211-6503-1327

**Renesas Electronics (China) Co., Ltd.**  
Room 1709 Quantum Plaza, No.27 ZhichunLu, Haidian District, Beijing, 100191 P. R. China  
Tel: +86-10-8235-1155, Fax: +86-10-8235-7679

**Renesas Electronics (Shanghai) Co., Ltd.**  
Unit 301, Tower A, Central Towers, 555 Langao Road, Putuo District, Shanghai, 200333 P. R. China  
Tel: +86-21-2226-0888, Fax: +86-21-2226-0999

**Renesas Electronics Hong Kong Limited**  
Unit 1601-1611, 16/F., Tower 2, Grand Century Place, 193 Prince Edward Road West, Mongkok, Kowloon, Hong Kong  
Tel: +852-2265-6688, Fax: +852-2886-9022

**Renesas Electronics Taiwan Co., Ltd.**  
13F, No. 363, Fu Shing North Road, Taipei 10543, Taiwan  
Tel: +886-2-8175-9600, Fax: +886-2-8175-9670

**Renesas Electronics Singapore Pte. Ltd.**  
80 Bendemeer Road, Unit #06-02 Hyflux Innovation Centre, Singapore 339949  
Tel: +65-6213-0200, Fax: +65-6213-0300

**Renesas Electronics Malaysia Sdn.Bhd.**  
Unit 1207, Block B, Menara Amcorp, Amcorp Trade Centre, No. 18, Jln Persiaran Barat, 46050 Petaling Jaya, Selangor Darul Ehsan, Malaysia  
Tel: +60-3-7955-9390, Fax: +60-3-7955-9510

**Renesas Electronics India Pvt. Ltd.**  
No.777C, 100 Feet Road, HAL 2nd Stage, Indiranagar, Bangalore 560 038, India  
Tel: +91-80-67208700, Fax: +91-80-67208777

**Renesas Electronics Korea Co., Ltd.**  
17F, KAMCO Yangjae Tower, 262, Gangnam-daero, Gangnam-gu, Seoul, 06265 Korea  
Tel: +82-2-558-3737, Fax: +82-2-558-5338