

D2 Audio DSP

Output Filter Design Selection

Abstract

This application note describes general guidelines for output stage filter component selection for use in Class-D audio amplifier applications using the D2 Audio DSP Digital Audio Processor devices. Recommended component selection values are provided and an overview describes typical effects of these recommended component values.

Contents

1. Overview	2
1.1 Output Configurations and Filters	2
1.2 Filter Operation Considerations	3
1.3 Loudspeaker Impedance Effects	4
1.4 Recommended Output Filter Components	4
1.5 Half-Bridge Bias Network	5
1.6 Inductor Characteristics	6
1.7 Capacitor Characteristics	6
2. Revision History	6

List of Figures

Figure 1. Full-Bridge Output and Filter	2
Figure 2. Half-Bridge Output and Filter	3

Related Literature

For a full list of related documents, visit our website:

- [Audio IC](#) pages

1. Overview

The D2 Audio DSP IC devices are complete System-on-Chip (SoC) audio processor and Class-D amplifier controllers. The devices combine a PWM controller and DSP audio processing, driving Class-D digital audio amplifier power stages.

The power stage outputs are driven by FET transistors that are either fully on or fully off. The result is a square wave format output, with a duty cycle that is proportional to the amplitude of the analog audio signal. A filter network connects between these outputs and the loudspeaker connections, integrating this switching PWM signal to produce the resulting audio-band output to drive the loudspeakers. This filter network is an important part of the design, directly affecting audio and system performance.

1.1 Output Configurations and Filters

Outputs can be either full bridge, or half-bridge, depending on the design configuration of the power stages. A full-bridge design drives the loudspeaker differentially from a pair of power stages, and uses a balanced filter design to accommodate this signal. A half-bridge design drives the loudspeaker from a single power stage output, using a ground reference as the loudspeaker's return path.

In both full-bridge and half-bridge configurations, a second-order LC filter reconstructs the audio output signal.

1.1.1 Full-Bridge Outputs

A full-bridge output uses two power stages, with both these power stages driving the loudspeaker with identical but opposite polarity audio signals. Both power stages of a full-bridge configuration are shown in [Figure 1](#). This topology provides twice the driving voltage to the loudspeaker than would be possible with only one output stage. Although requiring two power stages, the net benefit is that twice the voltage produces four times the output power.

$$(EQ. 1) \quad \left[P = \frac{(2V)^2}{R} \right]$$

1.1.2 Full-Bridge Filter

Because there are two power stage output signals, both are filtered using a balanced filtering network, as shown in [Figure 1](#).

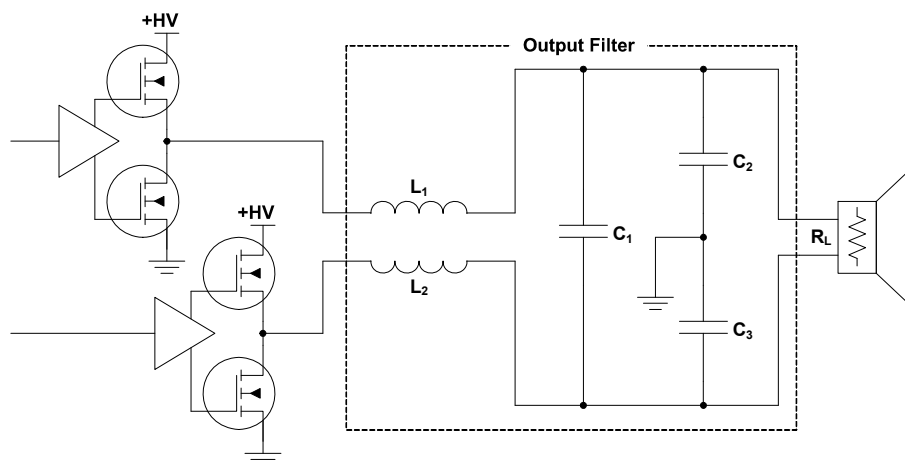

Figure 1. Full-Bridge Output and Filter

The total inductance of the LC filter is equally divided between the two inductors L_1 and L_2 , supporting a balanced path from both power stages. Their sum provides the equivalent single inductance of the LC filter.

The capacitance of the LC filter is built using the three capacitors shown in [Figure 1](#). C_2 and C_3 are high frequency bypass capacitors, forming a common-mode connection to the system ground to both loudspeaker leads, and also aids in EMI suppression. The series connection of C_2 and C_3 act in parallel with C_1 , providing the equivalent capacitance of the LC filter.

1.1.3 Half-Bridge Outputs

A half-bridge output uses one single power stage and drives the loudspeaker to an AC ground reference. The power stage output still provides the same peak-to-peak PWM switching magnitude as with the full-bridge configuration, but the loudspeaker is driven by only the peak-to-peak amplitude range as possible from that single power stage. Although its power output is lower than in a full-bridge configuration, only one power stage is required for that loudspeaker channel.

1.1.4 Half-Bridge Filter

The filter network for a half-bridge configuration is shown in [Figure 2](#).

Because the power stage's output switches between ground and the +HV supply voltage, the loudspeaker signal's midpoint resides at a DC offset of half this supply voltage. A DC bias network establishes an AC virtual ground reference as the loudspeaker's return path, supporting the DC offset from this single-stage configuration.

The bias network shown in [Figure 2](#) is the preferred method of providing the DC offset bias. This network divides the +HV voltage by half, thereby improving PSRR. Also, capacitors to +HV and to ground both act in parallel to provide an AC ground to the audio signal, allowing each capacitor to be half the value of what would otherwise be required with a single series capacitor.

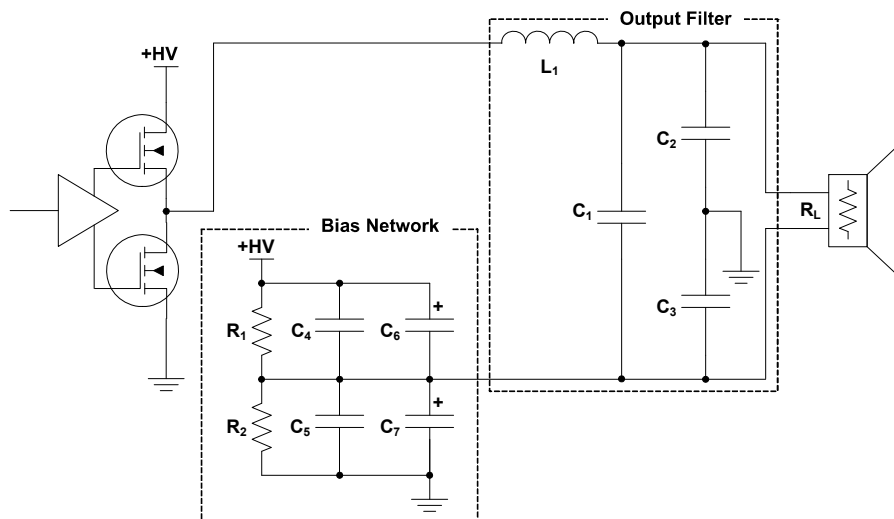

Figure 2. Half-Bridge Output and Filter

As also used in the full-bridge configuration, C_2 and C_3 are high frequency bypass capacitors, providing a common-mode ground reference for both loudspeaker leads, and contributing to the single equivalent capacitance of the LC filter.

The components of the bias network are not part of the output filter. The bias network simply provides a DC offset of half of the supply voltage, while also providing an AC ground return path for the loudspeaker audio signal.

1.2 Filter Operation Considerations

Design issues to consider include output topology, loudspeaker design impedance, output power range, and efficiency.

A second-order LC filter reconstructs the audio signal from the switched PWM output from the power stages. A second-order filter attenuates the frequency components above the filter's cutoff (-3dB) frequency by -40dB per decade. The output filter is a simple LC low-pass network, with a nominally-flat frequency response to audio-band output signals when loaded with the rated loudspeaker impedance.

The PWM switching operates at a frequency of 384kHz. Using a second-order LC filter with a -3dB cutoff filter frequency of 40kHz, levels across the loudspeaker load from the 384kHz switching rate are attenuated by 38dB. In an example of a nominal power stage providing 25W output into an 8Ω load, the audio-band voltage level is

approximately $14.1V_{RMS}$. Referencing this audio-level voltage, filtered content from the 384kHz switching therefore reduces to approximately 175mV.

1.3 Loudspeaker Impedance Effects

The loudspeaker forms the resistive element of the R-L-C filter network. While L and C determine the filter's cutoff frequency, the resistance value establishes the filter's damping factor and the flatness of the filter's passband response. Although actual loudspeakers exhibit dynamic impedance characteristics that are both resistive and reactive, their impedance is still dominated within the narrow range of their resistance value.

Ideally, filter L and C values are chosen to for their poles to occur at equal levels (that is, approximately a Butterworth-filter type response), establishing a flat passband response with minimum ripple anywhere within the audio frequency range. At the filter's cutoff frequency point, the resistance value contributes to the filter's transfer function, affecting whether the filter's response is critically-damped, over-damped, or under-damped. The cutoff frequency is designed to be sufficiently high above the audio frequencies, so critically damped or over-damped behavior has little effect on performance. However, an under-damped condition creates risk of resonant peaking at audio harmonics. For example, with a filter cutoff design frequency of 40kHz and the amplifier sourced with a 20kHz sine wave, an under-damped response can easily create high peaking at the second harmonic, leading to possibly damaging conditions for the amplifier and loudspeaker. For these reasons and to minimize such effects, loudspeaker design impedance is included when calculating and choosing filter component values.

1.4 Recommended Output Filter Components

[Table 1](#) provides typical recommended values for output filter network components. See [Figure 1 on page 2](#) for component references for the full-bridge configuration, and [Figure 2 on page 3](#) for component references for the half-bridge configuration.

Table 1. Output Filter Network Components

Output Configuration, Loudspeaker Load Impedance	Full-Bridge 8Ω	Half-Bridge 8Ω	Full-Bridge 6Ω	Half-Bridge 6Ω	Full-Bridge 4Ω	Half-Bridge 4Ω	Unit
Inductor L₁							
Inductance (±10%)	15	33	12	27	10	22	μH
Saturation Maximum Allowable Current (Note 1)	4	3.3	4.3	4	4.5	4.2	A
Temperature Coefficient	±10	±10	±10	±10	±10	±10	%
DC Resistance Typical	36	12	22	11	18	7	mΩ
Maximum	44	15	25	14	22	9	mΩ
Frequency Range	1	1	1	1	1	1	MHz
Inductor L₂							
Inductance (±10%)	15	N/A	12	N/A	10	N/A	μH
Saturation Maximum Allowable Current (Note 1)	4		4.3		4.5		A
Temperature Coefficient	±10		±10		±10		%
DC Resistance Typical	36		22		18		mΩ
Maximum	44		25		22		mΩ
Frequency Range	1		1		1		MHz
Capacitor C₁							
Capacitance (±10%)	0.47	0.33	0.68	0.47	1.0	1.0	μF
Voltage (DC + Peak) (Note 1)	50	50	50	50	50	50	V
Type	film	film	film	film	film	film	

Table 1. Output Filter Network Components (Continued)

Output Configuration, Loudspeaker Load Impedance	Full-Bridge 8Ω	Half-Bridge 8Ω	Full-Bridge 6Ω	Half-Bridge 6Ω	Full-Bridge 4Ω	Half-Bridge 4Ω	Unit
Capacitors C₂, C₃							
Capacitance (±10%)	0.1	0.1	0.1	0.1	0.1	0.1	μF
Voltage (DC + Peak) (Note 1)	50	50	50	50	50	50	V
Type	Ceramic X7R	Ceramic X7R	Ceramic X7R	Ceramic X7R	Ceramic X7R	Ceramic X7R	

Note:

- The current or voltage ratings shown are sufficient for amplifiers with design power ratings up to approximately 25W. Inductance and capacitance values listed define only the frequency and damping factors of the filter networks and are therefore appropriate regardless of design power. However, for designs built to provide higher power outputs, increase voltage and current ratings accordingly to accommodate the larger voltages and currents that can occur in these reactive networks. See further descriptions in this document regarding characteristics of inductors, capacitors, and loudspeaker impedances. For example, designs rated at 50W can produce a 20V_{RMS} voltage across the loudspeaker. To allow sufficient margin for the DC-plus peak voltages, capacitors with 100V or larger ratings are recommended. Size allowable current through filter inductors accordingly as the design output power increases.

1.5 Half-Bridge Bias Network

[Table 2](#) provides typical recommended values for output filter network components. The half-bridge bias network, shown in [Figure 2 on page 3](#), is not part of the output filter network. It is used in the half-bridge configuration to provide a DC bias voltage to eliminate any DC offset across the loudspeaker from the output stage, and also provides a low AC impedance return path for the audio signal.

The bias network components do not affect output filter performance but are part of the loudspeaker circuit path and therefore affect system performance. The capacitors in the bias network are in series connection with the loudspeaker load, and therefore form a single pole high-pass filtering function, with a roll-off at the low frequency end of the audio band. The two capacitors listed in [Table 2](#) act in parallel, and produce a roll-off of approximately 42Hz to 45Hz. These capacitor's values can be increased or decreased to accommodate the system's desired low-frequency performance.

Table 2. Half-Bridge Bias Network Components

Bias Network Capacitors C₄, C₅		
Capacitance	±10%	0.01μF
Voltage (DC + Peak) (see Note 1 in Table 1)		50V
Type		Ceramic X7R
Bias Network Capacitors C₆, C₇		
Capacitance 8Ω Load	±10%	220μF
6Ω Load		330μF
4Ω Load		470μF
Voltage (DC + Peak) (see Note 1 in Table 1)		25V
Type		Electrolytic
Bias Network Resistors R₁, R₂		
Resistance	±1%	10kΩ
Wattage		1/8W

1.6 Inductor Characteristics

The inductor is one of the most important elements in establishing audio amplifier performance. Its significant specifications are its DC resistance and its current ratings.

DC resistance should be as small as possible, because any resistance directly reduces output power delivered to the loudspeakers. Choose an inductor with a total maximum DC resistance of no more than 1.5% of the loudspeaker load. DC resistance should be listed in the inductor manufacturer's specifications.

The current rating of an inductor directly affects its ability to maintain its inductance rating while passing current. The inductor must have a high enough current rating to avoid magnetic saturation during times of highest operating current. Inductor permeability (its ability to maintain magnetization in presence of an increasing magnetizing current) is typically dynamic, affected by frequency and other effects. Inductor manufacturers typically specify their device inductance values as a function of DC current, and usually show this characteristic both as a listed DC saturation current, and graphically in a saturation curve. In choosing an inductor for use with Class-D amplifier filters, it is good design practice to use a current specification of at least 1.5 times the application's peak current. This allows for tolerance variation and for derating in higher temperature without risk of low margin, for continued optimum performance. For example, in an output stage that produces 25W into an 8Ω load, the peak current is approximately 2.5A. Using the 1.5 multiplier, an inductor with at least a 3.75A rating or larger should be used.

1.7 Capacitor Characteristics

Capacitors often exhibit dynamic nonlinearities of their dielectric as functions of current and frequency of AC signals. The capacitor is a critical component of the LC filter circuit, and to provide effective reactive operation, its effective series resistance should be as small as possible. In the recommended circuits, two types of capacitors are used. The single larger capacitor provides about 90% of the filter's capacitance, while the two smaller capacitors provide the remaining 10%. Dielectric material choice is important for highest performance operation. Film type capacitors are recommended for the larger capacitors and provide good performance at the switching frequencies and AC voltages used in these applications. The smaller capacitor values can also be film, although ceramic (X7R) types typically provide good performance and operation.

The capacitor voltage rating is important. For amplifiers producing output powers of 25W or less, peak voltages are seldom above 22V to 25V at the output stages, or at the loudspeaker. However, the capacitor is one element in a reactive resonant network. In normal operation with the loudspeaker providing a near-DC resistance of 8Ω, it is not realistic for the capacitor's voltage to exceed the actual value across the loudspeaker. Unless, in a situation where a loudspeaker is disconnected while operating, or if a loudspeaker's driver opens from failure, this low resistance is no longer present, and the capacitor becomes one element in a series LC resonant network. In these conditions, because of the highly reactive nature of the components, it is realistic for the actual voltage across the capacitor to double, above its expected operating range. Therefore, good design practice is to use capacitors rated at DC and AC voltage ratings of at least twice the highest supply voltage used in the output stages.

2. Revision History

Rev.	Date	Description
1.00	Jun.6.19	Initial release

Notice

1. Descriptions of circuits, software and other related information in this document are provided only to illustrate the operation of semiconductor products and application examples. You are fully responsible for the incorporation or any other use of the circuits, software, and information in the design of your product or system. Renesas Electronics disclaims any and all liability for any losses and damages incurred by you or third parties arising from the use of these circuits, software, or information.
2. Renesas Electronics hereby expressly disclaims any warranties against and liability for infringement or any other claims involving patents, copyrights, or other intellectual property rights of third parties, by or arising from the use of Renesas Electronics products or technical information described in this document, including but not limited to, the product data, drawings, charts, programs, algorithms, and application examples.
3. No license, express, implied or otherwise, is granted hereby under any patents, copyrights or other intellectual property rights of Renesas Electronics or others.
4. You shall not alter, modify, copy, or reverse engineer any Renesas Electronics product, whether in whole or in part. Renesas Electronics disclaims any and all liability for any losses or damages incurred by you or third parties arising from such alteration, modification, copying or reverse engineering.
5. Renesas Electronics products are classified according to the following two quality grades: "Standard" and "High Quality". The intended applications for each Renesas Electronics product depends on the product's quality grade, as indicated below.
 - "Standard": Computers; office equipment; communications equipment; test and measurement equipment; audio and visual equipment; home electronic appliances; machine tools; personal electronic equipment; industrial robots; etc.
 - "High Quality": Transportation equipment (automobiles, trains, ships, etc.); traffic control (traffic lights); large-scale communication equipment; key financial terminal systems; safety control equipment; etc.Unless expressly designated as a high reliability product or a product for harsh environments in a Renesas Electronics data sheet or other Renesas Electronics document, Renesas Electronics products are not intended or authorized for use in products or systems that may pose a direct threat to human life or bodily injury (artificial life support devices or systems; surgical implantations; etc.), or may cause serious property damage (space system; undersea repeaters; nuclear power control systems; aircraft control systems; key plant systems; military equipment; etc.). Renesas Electronics disclaims any and all liability for any damages or losses incurred by you or any third parties arising from the use of any Renesas Electronics product that is inconsistent with any Renesas Electronics data sheet, user's manual or other Renesas Electronics document.
6. When using Renesas Electronics products, refer to the latest product information (data sheets, user's manuals, application notes, "General Notes for Handling and Using Semiconductor Devices" in the reliability handbook, etc.), and ensure that usage conditions are within the ranges specified by Renesas Electronics with respect to maximum ratings, operating power supply voltage range, heat dissipation characteristics, installation, etc. Renesas Electronics disclaims any and all liability for any malfunctions, failure or accident arising out of the use of Renesas Electronics products outside of such specified ranges.
7. Although Renesas Electronics endeavors to improve the quality and reliability of Renesas Electronics products, semiconductor products have specific characteristics, such as the occurrence of failure at a certain rate and malfunctions under certain use conditions. Unless designated as a high reliability product or a product for harsh environments in a Renesas Electronics data sheet or other Renesas Electronics document, Renesas Electronics products are not subject to radiation resistance design. You are responsible for implementing safety measures to guard against the possibility of bodily injury, injury or damage caused by fire, and/or danger to the public in the event of a failure or malfunction of Renesas Electronics products, such as safety design for hardware and software, including but not limited to redundancy, fire control and malfunction prevention, appropriate treatment for aging degradation or any other appropriate measures. Because the evaluation of microcomputer software alone is very difficult and impractical, you are responsible for evaluating the safety of the final products or systems manufactured by you.
8. Please contact a Renesas Electronics sales office for details as to environmental matters such as the environmental compatibility of each Renesas Electronics product. You are responsible for carefully and sufficiently investigating applicable laws and regulations that regulate the inclusion or use of controlled substances, including without limitation, the EU RoHS Directive, and using Renesas Electronics products in compliance with all these applicable laws and regulations. Renesas Electronics disclaims any and all liability for damages or losses occurring as a result of your noncompliance with applicable laws and regulations.
9. Renesas Electronics products and technologies shall not be used for or incorporated into any products or systems whose manufacture, use, or sale is prohibited under any applicable domestic or foreign laws or regulations. You shall comply with any applicable export control laws and regulations promulgated and administered by the governments of any countries asserting jurisdiction over the parties or transactions.
10. It is the responsibility of the buyer or distributor of Renesas Electronics products, or any other party who distributes, disposes of, or otherwise sells or transfers the product to a third party, to notify such third party in advance of the contents and conditions set forth in this document.
11. This document shall not be reprinted, reproduced or duplicated in any form, in whole or in part, without prior written consent of Renesas Electronics.
12. Please contact a Renesas Electronics sales office if you have any questions regarding the information contained in this document or Renesas Electronics products.

(Note1) "Renesas Electronics" as used in this document means Renesas Electronics Corporation and also includes its directly or indirectly controlled subsidiaries.

(Note2) "Renesas Electronics product(s)" means any product developed or manufactured by or for Renesas Electronics.

(Rev.4.0-1 November 2017)

Corporate Headquarters

TOYOSU FORESIA, 3-2-24 Toyosu,
Koto-ku, Tokyo 135-0061, Japan
www.renesas.com

Contact Information

For further information on a product, technology, the most up-to-date version of a document, or your nearest sales office, please visit:
www.renesas.com/contact/

Trademarks

Renesas and the Renesas logo are trademarks of Renesas Electronics Corporation. All trademarks and registered trademarks are the property of their respective owners.