

RL78/G23, RL78/G22, RL78/G14

LoRa®-based Wireless Software Package

Introduction

This software package includes the following sample software and tools to evaluate the LoRa and LoRaWAN based wireless communication software for RL78 devices.

- **Radio Driver** supports LoRa/FSK modulation, packet Tx/Rx, CW, LBT and ARIB-STD-T108.
- **RadioEvalApp** is the evaluation tool for the radio functions. LPWA Studio is the GUI front end of RadioEvalApp.
- **Ping-pong** is a simple application based on the Radio Driver.
- **LPWA Power Estimator** is a simple power estimation tool.
- **LoRaWAN MAC** is a protocol stack compliant with the LoRaWAN Specification 1.0.3 and 1.0.4
- **LoRaSample** is a sample application based on the LoRaWAN MAC (Class A/B/C).
- **LoRaFuotaSample** is a sample LoRaWAN FUOTA (Firmware Update Over The Air) application.
- **LoRaSensorSample** is a sample LoRaWAN Sensor Node application.
Note: LoRaSensorSample is released as a separate “RL78/G23, RL78/G22, RL78/G14LoRaWAN Sensor Demo”.
- **LoRaWanPrivateLoRaComboSample** is a sample application that connects LoRaWAN and Private LoRa.
- **PrivateLoRaSample** is a sample application that enables private use of LoRa.

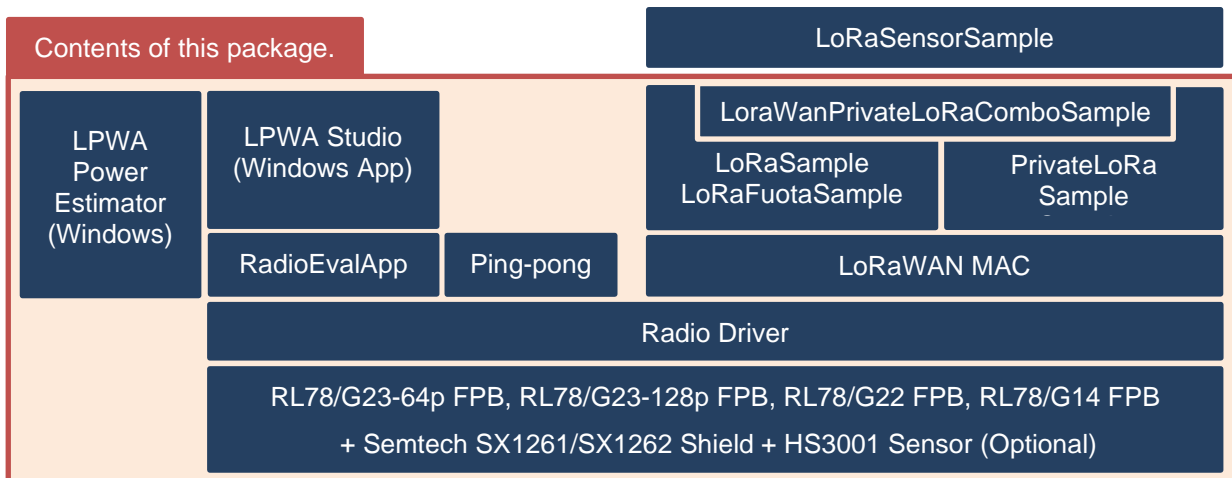

Note: LoRaSensorSample is released as a separate “RL78/G23, RL78/G22, RL78/G14LoRaWAN Sensor Demo”.

Note: FPB stands for Fast Prototyping Board.

For RL78/G23 and RL78/G22, MCU drivers are generated by RL78 Smart Configurator. Please refer to *Smart Configurator Usage for RL78 LoRa®-based Wireless Software Reference Guide* (R11AN0937) when MCU drivers need to be changed.

Note: Users can choose to generate the source code by using the Smart Configurator or change the source code without using Smart Configurator when to port the source code for user applications.

Target Device

RL78/G23, RL78/G22, RL78/G14

Contents

1.	Hardware Setup.....	3
1.1	Hardware Basic Setup for RL78/G23-64p Fast Prototyping Board.....	4
1.2	Hardware Advanced Setup for RL78/G23-64p Fast Prototyping Board	5
1.3	Hardware Basic Setup for RL78/G23-128p Fast Prototyping Board.....	6
1.4	Hardware Advanced Setup for RL78/G23-128p Fast Prototyping Board	7
1.5	Hardware Basic Setup for RL78/G22 Fast Prototyping Board	8
1.6	Hardware Advanced Setup for RL78/G22 Fast Prototyping Board.....	10
1.7	Hardware Setup for RL78/G14 Fast Prototyping Board.....	11
2.	Sample Application Software Setup.....	12
2.1	Setup Virtual COM Port Driver	12
2.2	Software setup for to run Pre-compiled Sample Applications.	12
2.3	Software setup for developing software based on the sample applications.	13
3.	Utility Tools Setup for Windows 10	14
4.	Resources Usage	15
4.1	Memory Resource Usage.....	15
4.2	Peripheral Resource Usage	16
	Revision History	17

1. Hardware Setup

This software package supports the following hardware configurations.

- For RL78/G23-64p Fast Prototyping Board + SX126x Shield + Sensor(optional):
To simply run the pre-compiled sample applications, please refer to [Hardware Basic Setup for RL78/G23-64p Fast Prototyping Board](#). To develop software based on the sample applications with E2Lite, please refer to [Hardware Advanced Setup for RL78/G23-64p Fast Prototyping Board](#).
- RL78/G23-128p Fast Prototyping Board + SX126x Shield + Sensor(optional):
To simply run the pre-compiled sample applications, please refer to [Hardware Basic Setup for RL78/G23-128p Fast Prototyping Board](#). To develop software based on the sample applications with E2Lite, please refer to [Hardware Advanced Setup for RL78/G23-128p Fast Prototyping Board](#).
- RL78/G22 Fast Prototyping Board + SX126x Shield + Sensor(optional):
To simply run the pre-compiled sample applications, please refer to [Hardware Basic Setup for RL78/G22 Fast Prototyping Board](#). To develop software based on the sample applications with E2Lite, please refer to [Hardware Advanced Setup for RL78/G22 Fast Prototyping Board](#).
- RL78/G14 Fast Prototyping Board + SX126x Shield + Sensor(optional):
To run the pre-compiled sample application or develop software based on the sample applications, please refer to [Hardware Setup for RL78/G14 Fast Prototyping Board](#).

References:

For more details on the each boards, please refer to the following websites:

- RL78/G23-64p Fast Prototyping Board (RTK7RLG230CLG000BJ)(https://www.renesas.com/rl78g23-64p_fpb)
- RL78/G23-128p Fast Prototyping Board (RTK7RLG230CSN000BJ)(https://www.renesas.com/rl78g23-128p_fpb)
- RL78/G22 Fast Prototyping Board (RTK7RLG220C00000BJ)(https://www.renesas.com/rl78g22_fpb)
- RL78/G14 Fast Prototyping Board (RTK5RLG140C00000BJ) (<https://www.renesas.com/rl78fpb>)
- Semtech SX1261 Shield (<https://www.semtech.com/products/wireless-rf/lora-transceivers/sx1261>)
- Semtech SX1262 Shield (<https://www.semtech.com/products/wireless-rf/lora-transceivers/sx1262>)
- Digilent Pmod USBUART (<https://reference.digilentinc.com/reference/pmod/pmodusbuart/start>)
- Renesas HS3001 Humidity and Temperature Sensor Pmod Module (US082-HS3001EVZ)
<https://www.renesas.com/us/en/products/sensor-products/humidity-sensors/us082-hs3001evz-relative-humidity-sensor-pmod-board-renesas-quick-connect-iot>

Important:

The use of wireless receivers and transmitters is restricted by international standards and domestic regulations. Wireless receivers and transmitters must therefore be used in accordance with the applicable laws and regulations of the country in which they are being used.

1.1 Hardware Basic Setup for RL78/G23-64p Fast Prototyping Board

This configuration is provided to simply run the pre-compiled sample applications for RL78/G23(64pin). Please setup the boards and cables shown as below.

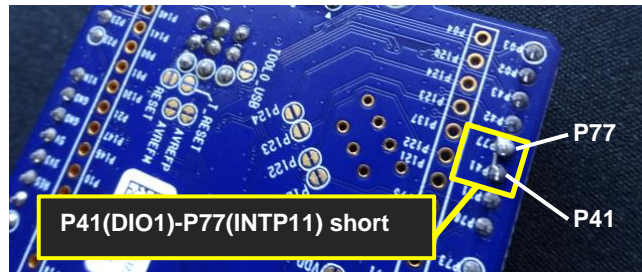
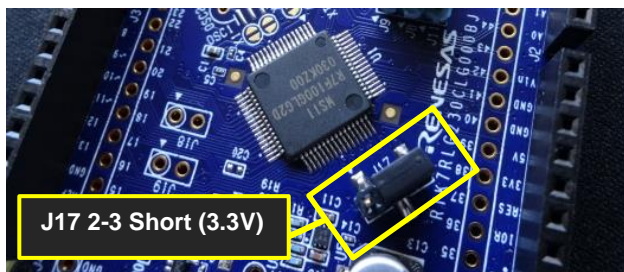
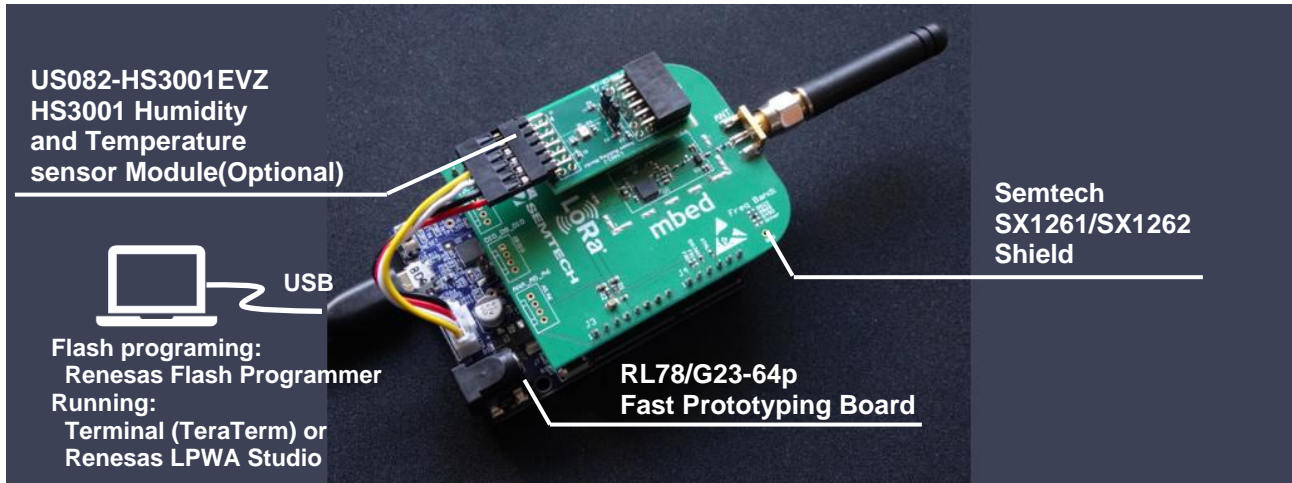

Note1: Power supply selection header (J17: default 5V) should be changed to 3.3V(J17 2-3 short).

Note2: P41(SX126x.DIO1 interrupt signal) and P77(RL78/G23.INTP11) should be short by jumper wire.

Note3: Optional HS3001 Humidity and Temperature Sensor Pmod Module should be connected to the Grove(J10) connector (following Pmod <-> Grove conversion cable is required.)

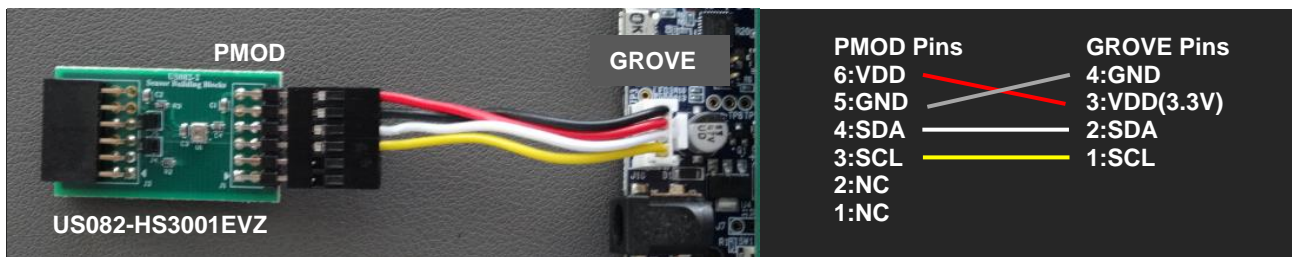

IMPORTANT:

In this configuration, the RL78/G23 is reset when you connect or reconnect the COM Port associated with RL78/G23-64p Fast Prototyping Board. After connecting to the COM port, you should wait for 2-3 seconds for the MCU to boot up before sending AT commands.

If you don't want the MCU to be reset when the COM port is re-connected, there is a workaround below.

- Cut pattern on RESET (See next section)
- Mount the 3pin header on J11(See next section)
- J11 1-2 short for downloading a sample application.
- J11 2-3 short for running a sample application.

1.2 Hardware Advanced Setup for RL78/G23-64p Fast Prototyping Board

This configuration is provided to develop the software based on the sample applications for RL78/G23. To debug the software, E2Lite is required because all sample applications use the USB-UART interface which is conflict with the COM Port debug interface. To enable the E2Lite debug interface, the following board modifications are required because RL78/G23-64p Fast Prototyping Board is configured for COM Port debug interface by default.

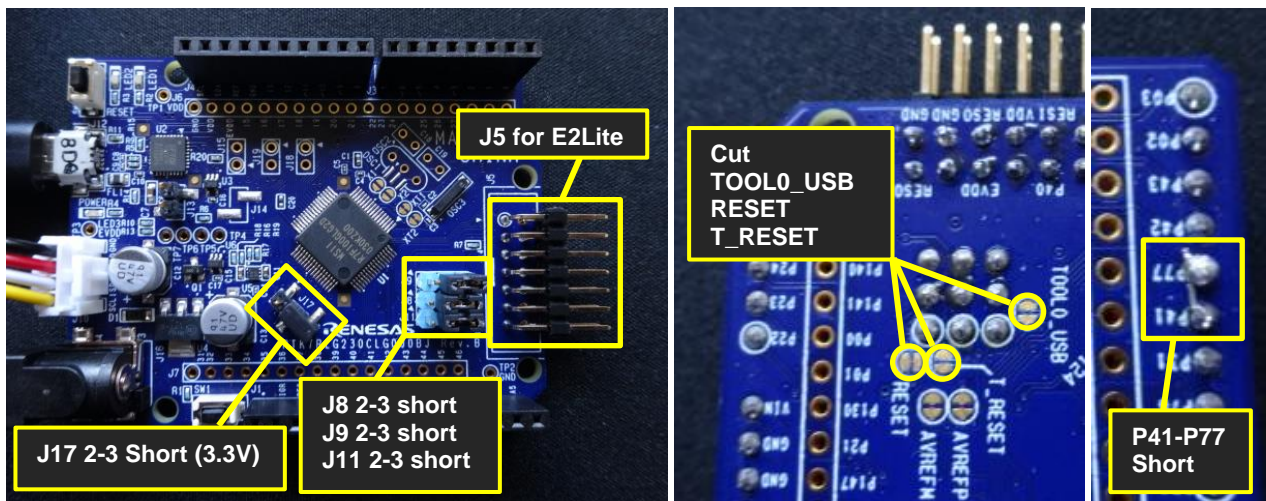
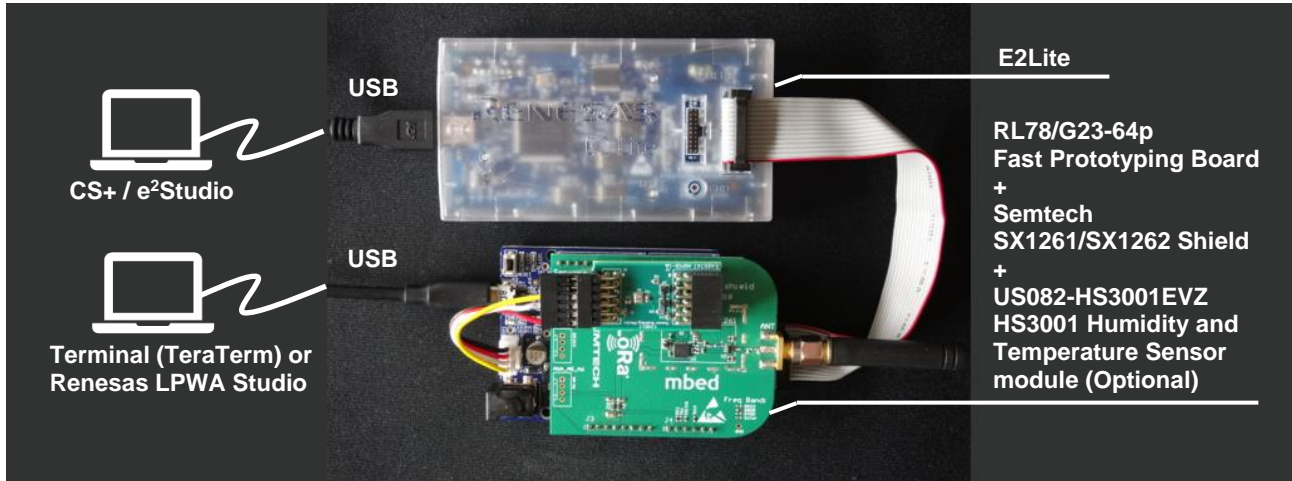

STEP1: Setup the board by referring to the basic setup section.

STEP2: For E2Lite, modify the board with following instruction, and connect to the E2Lite.

Mount the 14pin Dual Right Angle pin header on J5 (for E2Lite).

Mount the 3pin header on J8, J9 and J11. Short 2-3.

Cut pattern on TOOL0_USB, RESET and T_RESET.

STEP3: Plug the SX126x shield. Plug the US082-HS3001EVZ (optional).

For more detail regarding E2Lite integration, please refer to the following websites.

- RL78/G23-64p Fast Prototyping Board (RTK7RLG230CLG000BJ)(https://www.renesas.com/rl78g23-64p_fpb)

1.3 Hardware Basic Setup for RL78/G23-128p Fast Prototyping Board

This configuration is provided to simply run the pre-compiled sample applications for RL78/G23(128pin).

Please setup the boards and cables shown as below.

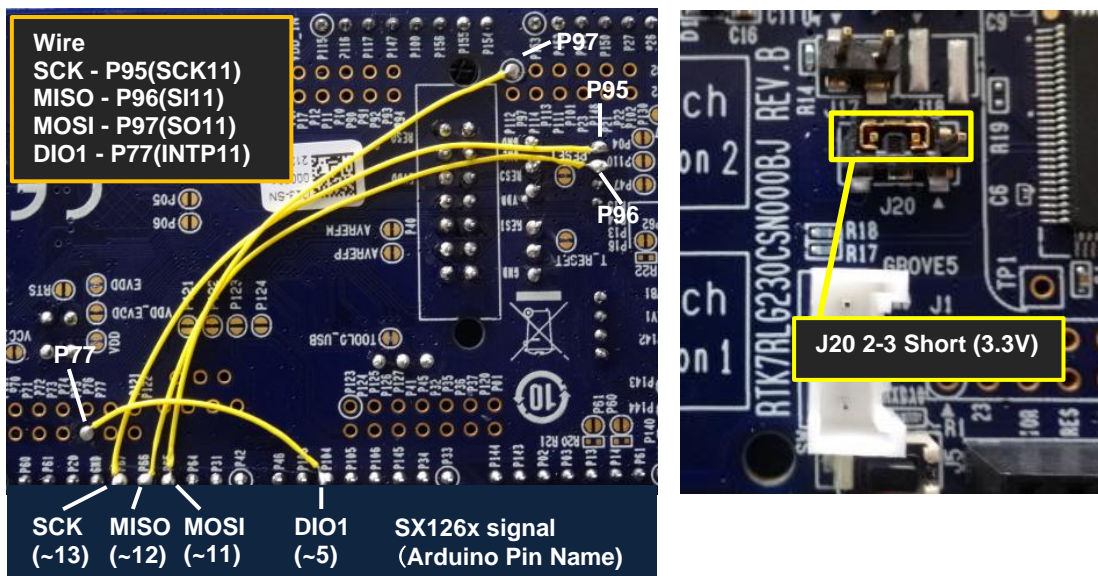
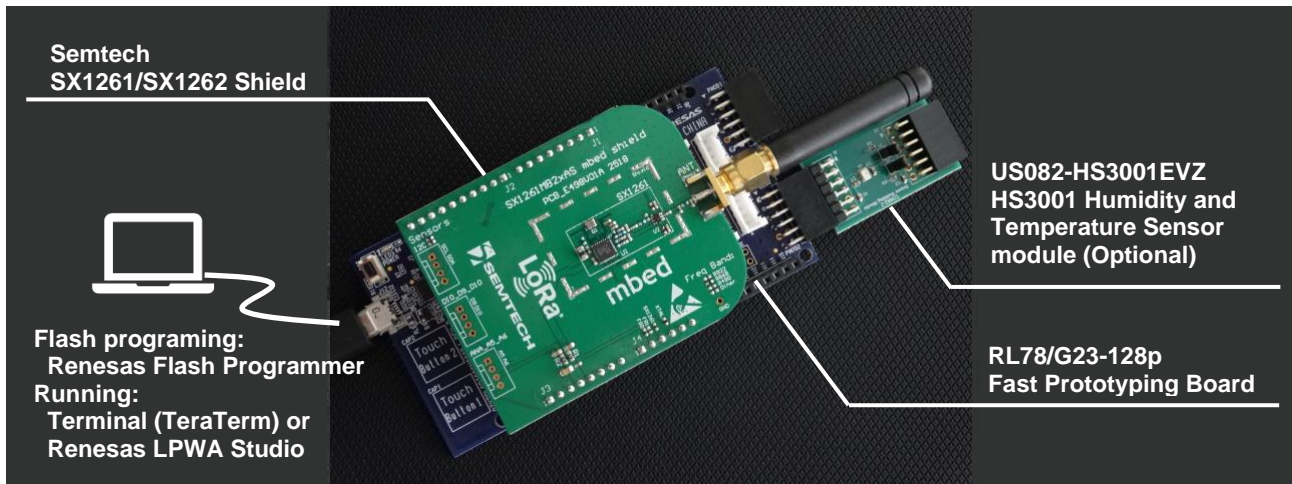

- STEP1: Wire SX126x(SCK,MISO,MOSI and DIO1) to RL78/G23(SCK11,SI11,SO11, and INTP11).
- STEP2: Power supply selection header (J20: default 5V) should be changed to 3.3V(J20 2-3 short).
- STEP3: Plug the SX126x shield. Plug the US082-HS3001EVZ on the PMOD2 connector (Optional).

IMPORTANT:

In this configuration, the RL78/G23 is reset when you connect or reconnect the COM Port associated with RL78/G23-128p Fast Prototyping Board. After connecting to the COM port, you should wait for 2-3 seconds for the MCU to boot up before sending AT commands.

If you don't want the MCU to be reset when the COM port is re-connected, there is a workaround below.

- Cut pattern on RESET (See next section)
- Mount the 3pin header on J19(See next section)
 - J19 1-2 short for downloading a sample application.
 - J19 2-3 short for running a sample application.

1.4 Hardware Advanced Setup for RL78/G23-128p Fast Prototyping Board

This configuration is provided to develop the software based on the sample applications for RL78/G23. To debug the software, E2Lite is required because all sample applications use the USB-UART interface which is conflict with the COM Port debug interface. To enable the E2Lite debug interface, following board modifications are required because RL78/G23-128p Fast Prototyping Board is configured for COM Port debug interface by default.

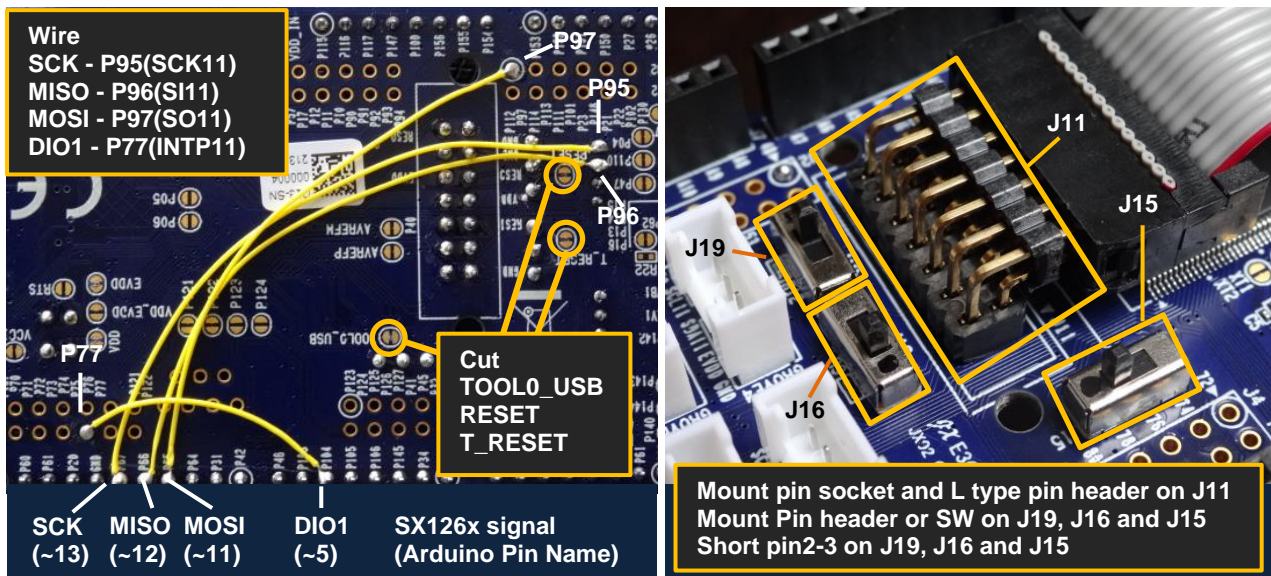
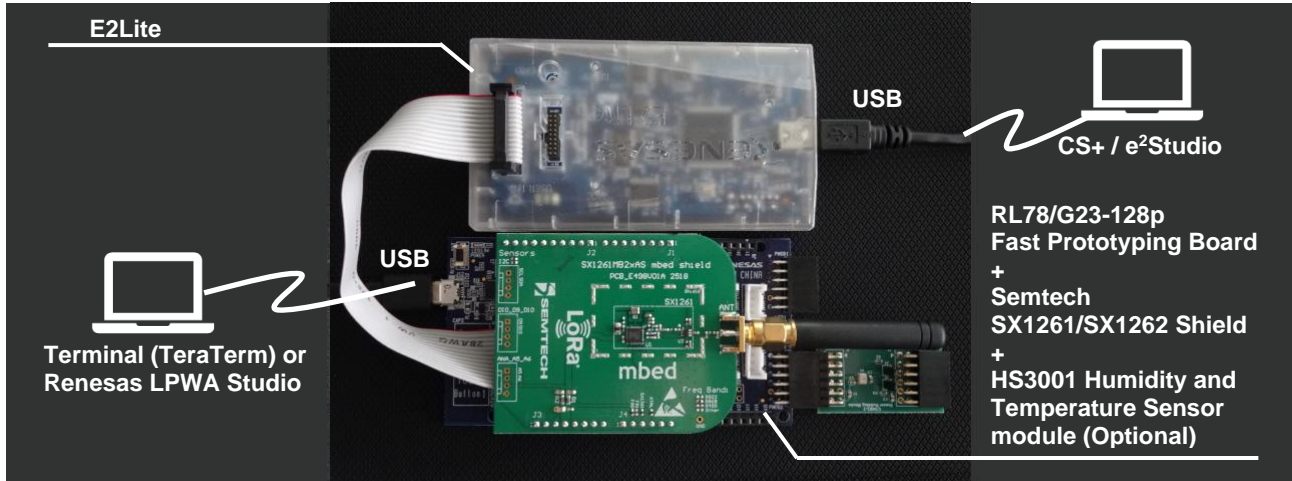

STEP1: Setup the board by referring to the basic setup section.

STEP2: For E2Lite, modify the board with following instruction, and connect to the E2Lite.

Cut pattern on TOOL0_USB, RESET, and T_RESET.

Mount low-height 14 pin dual pin socket and 14pin dual right angle pin header on J11

Mount 3pin header or SPDT(3P) on J15, J16 and J19. Short pin2-3 on J15, J16, and J19.

STEP3: Connect E2Lite cable on J11. Plug the SX126x shield.

For more detail regarding E2Lite integration, please refer to the following websites.

- RF78/G23-128p Fast Prototyping Board (RTK7RLG230CSN000BJ)(https://www.renesas.com/rl78g23-128p_fpb)

1.5 Hardware Basic Setup for RL78/G22 Fast Prototyping Board

This configuration is provided to simply run the pre-compiled sample applications for RL78/G22. Please setup the boards and cables shown as below.

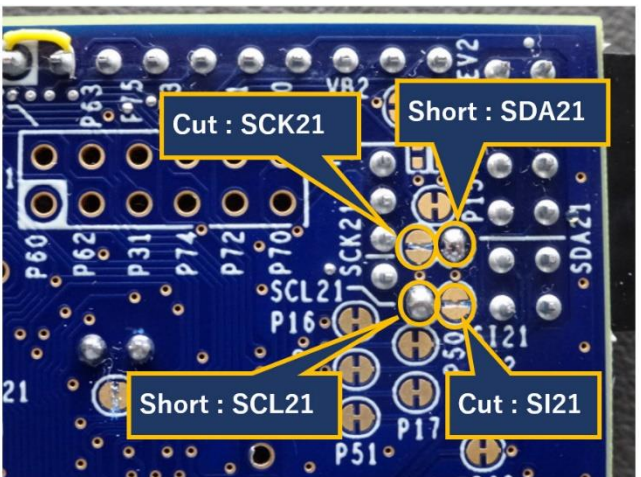
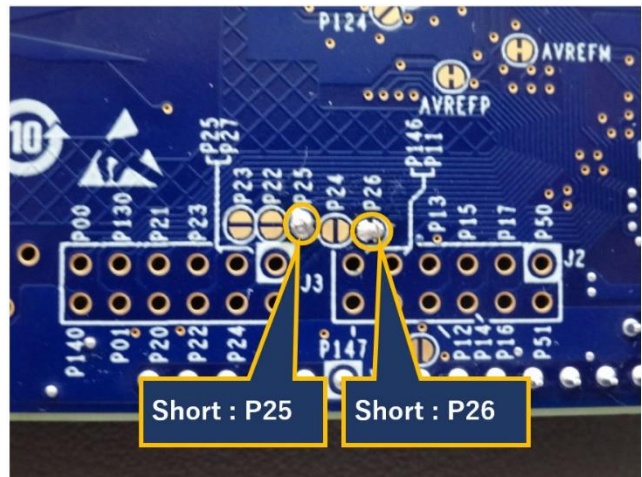
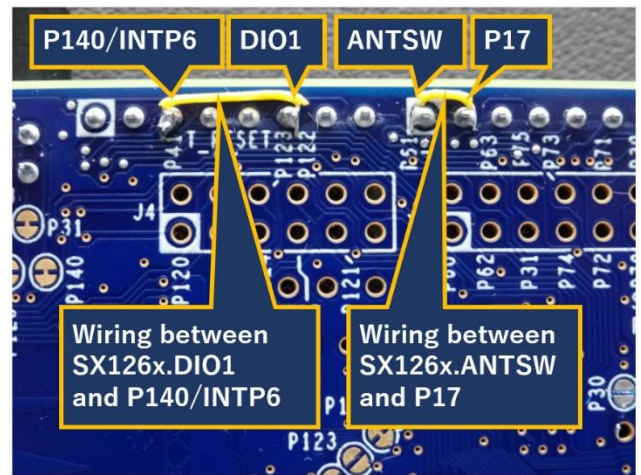
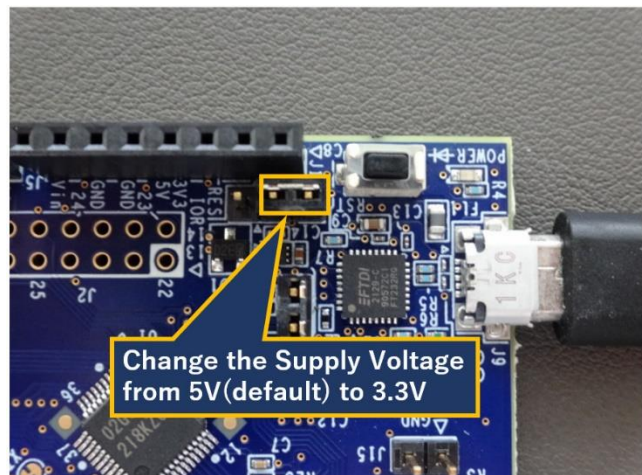
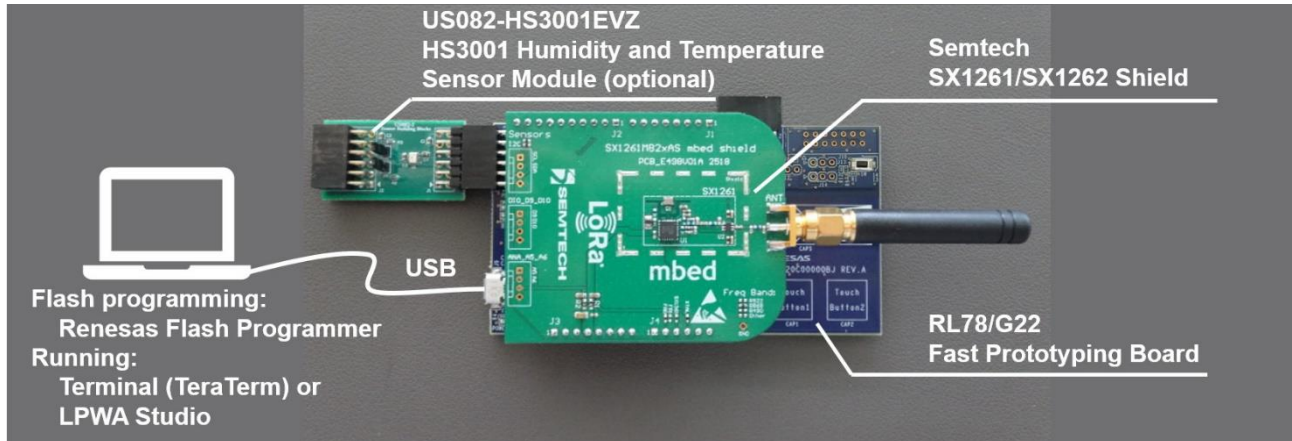

Note1: Power supply selection header (J17: default 5V) should be changed to 3.3V(J17 2-3 short).

Note2: DIO1(SX126x Shield) and P140/INTP6(RL78/G22) should be short by jumper wire. In addition, ANTSW(SX126x Shield) and P17(RL78/G22) should be short by jumper wire.

Note3: PAD P25 and P26 should be short (these ports are not connected to Arduino Pin Header by default).

Note4: If you use US082-HS3001EVZ with PMOD2, PMOD2 should be configured as PMOD Type 6A (I2C) by cutting the patterns for SI21 and SCK21 and shortening the pads SCL21 and SDA21.

IMPORTANT:

In this configuration, the RL78/G22 is reset when you connect or reconnect the COM Port associated with RL78/G22 Fast Prototyping Board. After connecting to the COM port, you should wait for 2-3 seconds for the MCU to boot up before sending AT commands.

If you don't want the MCU to be reset when the COM port is re-connected, there are two workarounds.

Way 1:

J16 short for downloading a sample application.

J16 open for running a sample application.

Way 2:

Cut the pattern on RESET (See next section)

Mount the SPDT or 3pin header on J14 (See next section)

J14 1-2 short for downloading a sample application.

J14 2-3 short for running a sample application.

1.6 Hardware Advanced Setup for RL78/G22 Fast Prototyping Board

This configuration is provided to develop the software based on the sample applications for RL78/G22. To debug the software, E2Lite is required because all sample applications use the USB-UART interface which is conflict with the COM Port debug interface. To enable the E2Lite debug interface, the following board modifications are required because RL78/G22 Fast Prototyping Board is configured for COM Port debug interface by default.

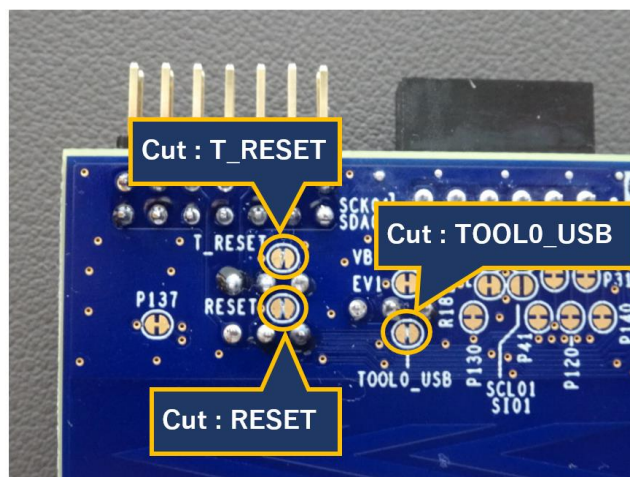
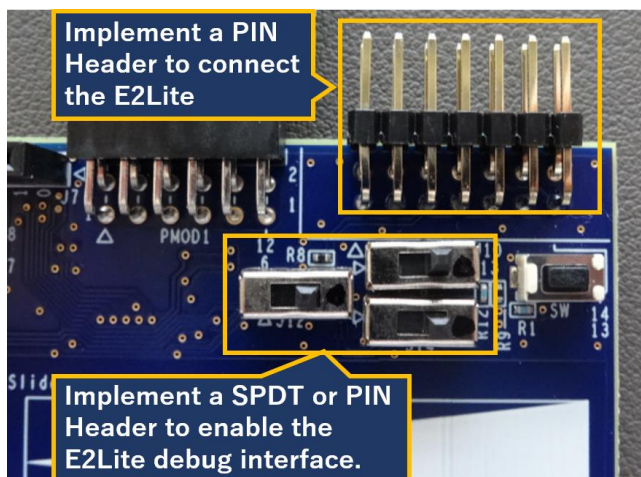
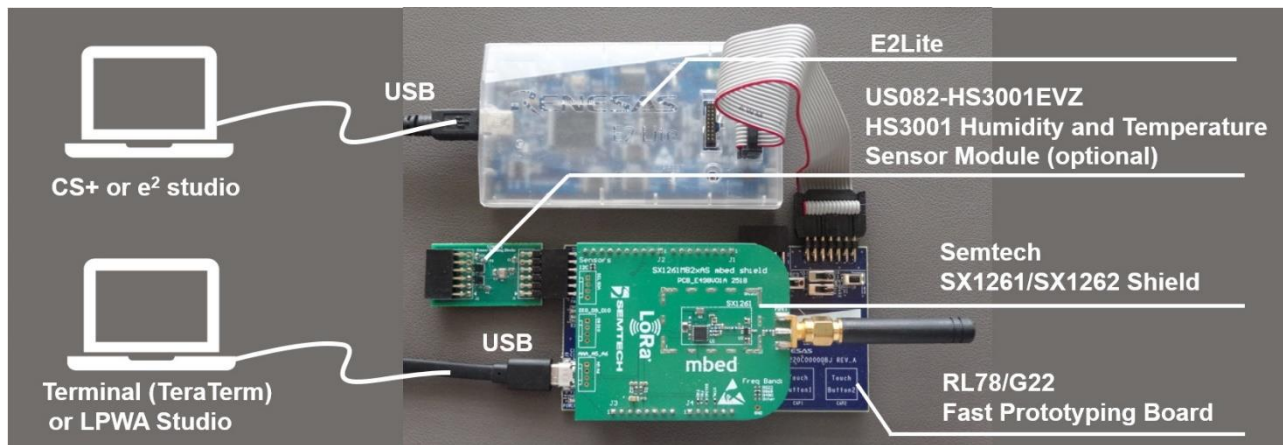

STEP1: Setup the board by referring to the basic setup section.

STEP2: For E2Lite, modify the board with following instruction, and connect to the E2Lite.

Mount the 14pin Dual Right Angle pin header on J10 (for E2Lite).

Mount the SPDT or 3pin header on J12, J13 and J14. Short 2-3.

Cut pattern on TOOL0_USB, T_RESET and RESET.

STEP3: Plug the SX126x shield. Plug the US082-HS3001EVZ (optional).

For more detail regarding E2Lite integration, please refer to the following websites.

- RL78/G22 Fast Prototyping Board (RTK7RLG220C00000BJ) (https://www.renesas.com/rl78g22_fpb)

1.7 Hardware Setup for RL78/G14 Fast Prototyping Board

This configuration is provided to run the pre-compiled sample application or develop software based on the sample applications for RL78/G14. Please setup the boards and cables shown as below.

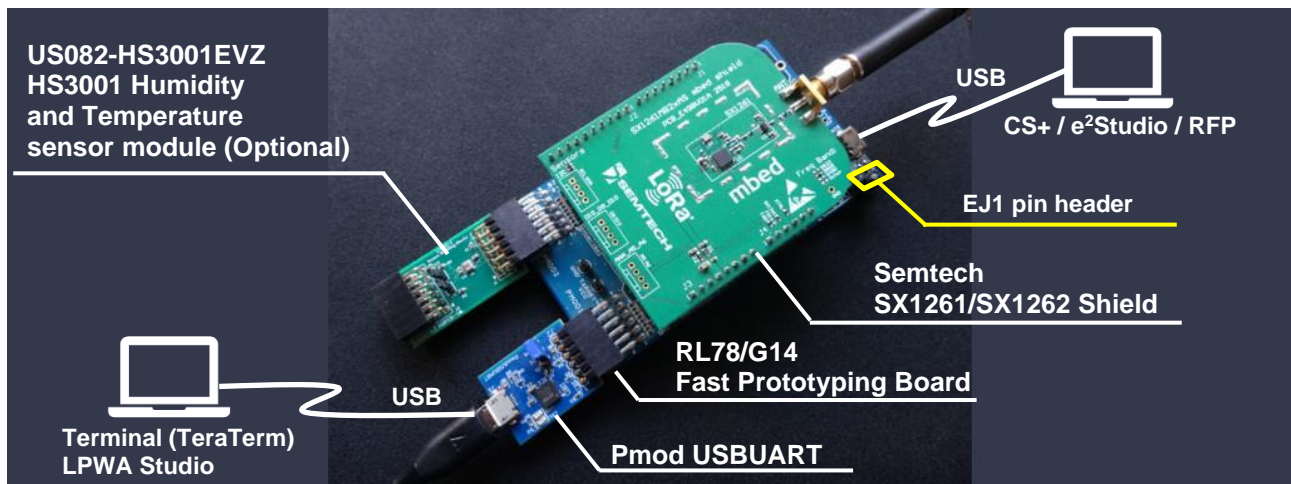

Note1: For Flash Programming or Debugging with IDE(CS+/e²studio), EJ1 pin header should be OPEN.

After Flash Programming, standalone operation w/o IDE can be enabled by setting EJ1 to SHORT.

Note2: Pmod USBUART(USB-Serial Converter) should be connected to the PMOD1 connector.

Note3: Plug the US082-HS3001EVZ on the PMOD2 connector (Optional)

2. Sample Application Software Setup

This software package includes the following sample applications.

- **RadioEvalApp** (Radio Evaluation Program with AT-command)
- **ping-pong** (simple application using radio driver)
- **LoRaSample** (LoRaWAN sample application with AT-command)
- **LoRaFuotaSample** (Firmware Update over LoRaWAN sample application with AT-command)
- **PrivateLoRaSample** (Private LoRa sample application with AT-command)
- **LoRaWanPrivateLoRaComboSample** (Combination of PrivateLoRa and LoRaWAN sample application with AT-command)

Note1: Pre-compiled sample application for the ping-pong is not provided.

Note2: LoRaSensorSample is released as a separate “RL78/G23, RL78/G22, RL78/G14LoRaWAN Sensor Demo”.

Note3: **LoRaFuotaSample** does not support RL78/G23-64p and RL78/G22 Fast Prototyping Board.

Note4: **LoRaWanPrivateLoRaComboSample** does not support RL78/G22 Fast Prototyping Board.

2.1 Setup Virtual COM Port Driver

STEP1. Visit <https://fdichip.com/drivers/vcp-drivers/> . Download “setup executable” for Windows.

STEP2. Unzip CDMxxxx_Setup.zip and run installer.

2.2 Software setup for to run Pre-compiled Sample Applications.

STEP1. Install the Renesas Flash Programmer V3.16.00 or later.

STEP2. Download the sample application (.mot file) to the MCU with Renesas Flash Programmer.

Click **File > Click New Project ..**

Microcontroller:

Choose **RL78/G2x** for RL78/G23-64p, RL78/G23-128p and RL78/G22 Fast Prototyping Board.

Choose **RL78** for RL78/G14 Fast Prototyping Board.

Project Name: any (for example, “sample1”)

Project Folder: any (for example, “C:\Temp\rfp”)

Communication:

For RL78/G23-64p, RL78/G23-128p, RL78/G22 Fast Prototyping Board (in case of basic setup)

Tool: “COM port”, Interface: “2 wire UART”, Click “Tool Dtails..” > Select your COM Port

For RL78/G23-64p, RL78/G23-128p, RL78/G22 Fast Prototyping Board (in case of advanced setup)

Tool: “E2 emulator Lite”

For RL78/G14 Fast Prototyping Board

Tool: “E2 emulator Lite”

Click **Connect**

Choose pre-compiled sample application file (for example, RadioEvalApp.mot).

pre-compiled sample application file are located in

(package top)\samples\project\e2studio\{BOARD}\{APPS}\DefaultBuild\{APPS}.mot

{BOARD}: rl78g23-64pfpb_sx126x, rl78g23-128pfpb_sx126x,
rl78g22fpb_sx126x or rl78g14fpb_sx126x,

{APPS}: RadioEvalApp, LoRaSample, LoRaFuotaSample, PrivateLoRa,
LoRaWanPrivateLoRaComboSample (, LoRaSensorSample).

Note1: LoRaFuotaSample does not support RL78/G23-64p and RL78/G22 Fast Prototyping Board.

Note2: LoRaWanPrivateLoRaComboSample does not support RL78/G22 Fast Prototyping Board.

Note3: LoRaSample_{REGION}.mot and LoRaSensorSample_{REGION}.mot are used instead of LoRaSample.mot and LoRaSensorSample.mot.

{REGION}: as923, au915, eu868, in865, kr920, us915.

Click **Start**. If OK is shown, click **File > Exit**

STEP3. Connect to the sample application with TeraTerm or Renesas LPWA Studio.

Serial settings: 115200pbs, 8bit, no parity, 1 stop bit, no flow control, CR+LF, local echo ON

2.3 Software setup for developing software based on the sample applications.

STEP1. Install the following IDE and C compiler.

CS+ for CC V8.12.00 with CC-RL V1.14.00 ([CS+ | Renesas](#))
or e2 studio 2024-07 with CC-RL V1.14.00 ([e2 studio | Renesas](#))

STEP2. Open project file with CS+ or Import project file with e²studio.

The project files are located in

```
(package top)\samples\project\{IDE}\{BOARD}\{APPS}\
{IDE} : csplus or e2studio,
{BOARD} : rl78g23-64pfpb_sx126x, rl78g23-128pfpb_sx126x,
          rl78g22fpb_sx126x, or rl78g14fpb_sx126x,
{APPS} : RadioEvalApp, LoRaSample, LoRaFuotaSample, PrivateLoRa,
          LoRaWanPrprivateLoRaComboSample (, LoRaSensorSample).
```

Note1: LoRaFuotaSample does not support RL78/G23-64p and RL78/G22 Fast Prototyping Board.

Note2: LoRaWanPrivateLoRaComboSample does not support RL78/G22 Fast Prototyping Board.

Note3: All project files are configured to use the E2Lite as debug interface by default.

[e² studio]

STEP 1. Import project file with e² studio.

Click **File** on Menu > Select **Import..**

Click **General** > Select **Existing Projects into workspace** > Click **Next**

Click **Browse..** > Choose following project folder as "root directory" > Click **Finish**

```
(package install top folder)\samples\project\e2studio\{BOARD}\{APPS}\
{BOARD} : rl78g23-64pfpb_sx126x, rl78g23-128pfpb_sx126x,
          rl78g22fpb_sx126x, or rl78g14fpb_sx126x,
{APPS} : RadioEvalApp, LoRaSample, LoRaFuotaSample, PrivateLoRa,
          LoRaWanPrprivateLoRaComboSample (, LoRaSensorSample).
```

Note1: "Copy projects into workspace" option should NOT be selected.

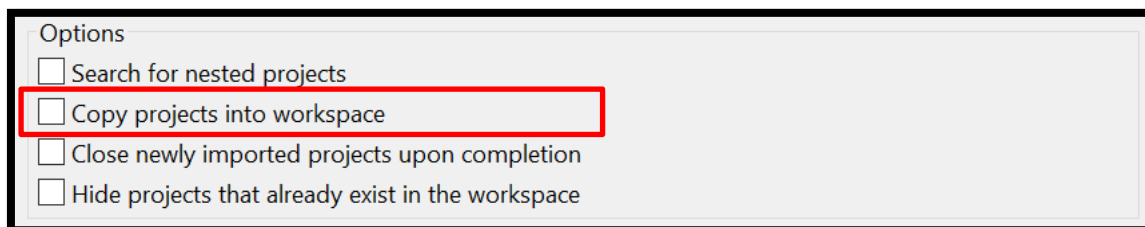

STEP 2. Click Build Icon  > Click Debug Icon  > Click  button twice.

[CS+]

Open or double click the project file (e.g., "RadioEvalApp.mtpj")

After loading the project file, click  button > click  button.

3. Utility Tools Setup for Windows 10

- Renesas LPWA Studio (Windows GUI frontend for RadioEvalApp)
Double-Click following windows installer.

(package top)\samples\tools\RLPWASudio\setup.exe

If you use this tool with Wireshark, additional setup is required.

For more detail, please refer to "Renesas LPWA Studio User's Manual" (R30UZ0095).

- Renesas LPWA Power Estimator (Windows Excel application program)
Open the following spreadsheet.

(package top)\samples\tools\RLPWAPowerEstimator\RLPWAPowerEstimator.xlsx

4. Resources Usage

4.1 Memory Resource Usage

Compiler: CC-RL V1.14.00,

Optimize options: -Osize, -goptimize, -OPTimize=SYmbol_delete

Memory model: Medium (RL78/G23, RL78/G14), Small (RL78/G22)

RL78 Smart Configurator V1.11.0 (RL78/G23 and RL78/G22 use it.)

Memory Size Unit: KiB(=1024Bytes)

Application	RL78/G23-64p FPB*1		RL78/G23-128p FPB*1		RL78/G22 FPB*1		RL78/G14 FPB*1	
	ROM	RAM	ROM	RAM	ROM	RAM	ROM	RAM
Radio Driver Only *2	14.6	0.6	14.7	0.6	14.0	0.6	16.3	0.6
Ping-pong *8	15.9	1.7	16.0	1.7	15.3	1.7	17.5	1.8
RadioEvalApp *8	41.6	4.2	41.6	4.2	39.9	4.0	47.1	4.7
LoRaWAN MAC Only *3	26.2	2.3	26.2	2.3	22.6	1.6	26.2	2.3
LoRaSample *3 *4 *8	63.5	5.1	63.6	5.1	56.0	3.8	68.6	5.6
LoRaFuotaSample*3 *5 *8	N/A	N/A	93.5	25.9	N/A	N/A	86.9	24.7
LoRaSensorSample *3 *6 *8	N/A	N/A	65.9	5.1	58.4	3.8	70.8	5.6
LoRaWanPrivateLoRaCom boSample*3 *7 *8	85.8	6.0	85.9	6.0	N/A	N/A	90.8	6.5
PrivateLoRaSample*3*8	52.1	3.5	52.1	3.5	48.8	3.4	55.6	3.9

Note1: FPB stands for Fast Prototyping Board.

Note2: ROM/RAM size includes .RLIB, .SLIB and the lower layer's code required by Radio driver.

An additional ROM(4.8KiB(RL78/G23), 4.5 KiB(RL78/G22), 4.7 KiB(RL78/G14)) / RAM(0.1 KiB) are required when ARIB-STD-T108 compliant function is enabled by RP_USE_RADIO_CFG_CHECK macro.

Note3: In case of RL78/G23 and RL78/G14, LoRaWAN V1.0.4, Class A/C, multicast and region EU868 are enabled. An additional ROM(9.7KiB) / RAM(0.3KiB) are required when Class B is enabled by LORAMAC_CLASSB_ENABLED macro. In case of RL78/G22, LoRaWAN V1.0.4, Class A/C and region EU868 are enabled, and Class B and multicast are not supported.

Note4: ROM/RAM sizes include LoRaWAN MAC, Radio Driver, and the lower layer's code required by LoRaSample. An additional ROM(11.1KiB(RL78/G23), 11KiB(RL78/G14)) / RAM(0.3KiB) are required when Class B is enabled by LORAMAC_CLASSB_ENABLED macro.

Note5: ROM/RAM sizes include LoRaWAN MAC, Radio Driver, and the lower layer's code required by LoRaFuotaSample. An additional ROM(11.6KiB) / RAM(0.3KiB) are required when Class B is enabled by LORAMAC_CLASSB_ENABLED macro.

Note6: ROM/RAM sizes include LoRaWAN MAC, Radio Driver, and the lower layer's code required by LoRaSensorSample. An additional ROM(11.1KiB) / RAM(0.3KiB) are required when Class B is enabled by LORAMAC_CLASSB_ENABLED macro. LoRaSensorSample are not included in this package.

Note7: ROM/RAM sizes include LoRaWAN MAC, Radio Driver, and the lower layer's code required by LoRaWanPrivateLoRaComboSample. An additional ROM(11KiB) / RAM(0.3KiB) are required when Class B is enabled by LORAMAC_CLASSB_ENABLED macro.

Note8: Stack size (1.0KiB) is included in the RAM size.

4.2 Peripheral Resource Usage

Resources	Function	RL78/G23-64p FPB	RL78/G23-128p FPB	RL78/G22 FPB	RL78G/14 FPB
Timer	----	TML32 TAU02	TML32 TAU02	TML32 TAU02	RTC Timer RJ 12bit IT
SX126x	CLK MISO MOSI ANTSW NSS DIO1 BUSY XTAL_SEL DEVICE_SEL FREQ_SEL NRESET	SCK11(P30) SI11(P50) SO11(P51) OUT(P73) OUT(P76) INTP11(P77) IN(P42) IN(P25) IN(P24) IN(P23/RFU) OUT(P22)	SCK11(P95) SI11(P96) SO11(P97) OUT(P42) OUT(P46) INTP11(P77) IN(P106) IN(P147) IN(P117) IN(P116/RFU) OUT(P115)	SCK20(P15) SI20(P14) SO20(P13) OUT(P17) OUT(P146) INTP6(P140) IN(P31) IN(P25) IN(P26) IN(P27/RFU) OUT(P147)	SCK31(P54) SI31(P53) SO31(P52) OUT(P03) OUT(P02) INTP11(P77) IN(P75) IN(P23) IN(P24) IN(P25/RFU) OUT(P26)
UART	Tx Rx	TxD0(P12) RxD0(P11)	TxD0(P12) RxD0(P11)	TxD0(P12) RxD0(P11)	TxD0(P51) RxD0(P50)
I ² C(Optional) for sensor	SCL SDA	SCLA1(P62) SDAA1(P63)	SCLA1(P62) SDAA1(P63)	SCL21(P70) SDA21(P71)	SCLA0(P14) SDAA0(P15)

Note: FPB stands for Fast Prototyping Board.

Revision History

Rev.	Date	Description	
		Page	Summary
4.00	Aug. 29, 22	All	Initial version.
4.10	Nov. 29, 22	10	Changed supported IDEs and toolchains.
		12	Update Memory Resource Usage
		13	Fixed typos
4.20	Mar. 31, 23	10	Changed supported IDEs and toolchains.
		12	Update Memory Resource Usage
4.30	Jun. 30, 23	All	Supports RL78/G22 Fast Prototyping board.
4.40	Dec. 22, 23	1	Added LoRaWanPrivateLoRaComboSample and PrivateLoRaSample
		12,13	Changed supported IDEs and toolchains.
		15	Update Memory Resource Usage
4.60	Sep. 27, 24	1	Add description about RL78 Smart Configurator.
		12,13	Change supported IDEs and toolchains.
			Update components of sample application.
		15	Update Memory Resource Usage.

General Precautions in the Handling of Microprocessing Unit and Microcontroller Unit Products

The following usage notes are applicable to all Microprocessing unit and Microcontroller unit products from Renesas. For detailed usage notes on the products covered by this document, refer to the relevant sections of the document as well as any technical updates that have been issued for the products.

1. Precaution against Electrostatic Discharge (ESD)

A strong electrical field, when exposed to a CMOS device, can cause destruction of the gate oxide and ultimately degrade the device operation. Steps must be taken to stop the generation of static electricity as much as possible, and quickly dissipate it when it occurs. Environmental control must be adequate. When it is dry, a humidifier should be used. This is recommended to avoid using insulators that can easily build up static electricity.

Semiconductor devices must be stored and transported in an anti-static container, static shielding bag or conductive material. All test and measurement tools including work benches and floors must be grounded. The operator must also be grounded using a wrist strap. Semiconductor devices must not be touched with bare hands. Similar precautions must be taken for printed circuit boards with mounted semiconductor devices.

2. Processing at power-on

The state of the product is undefined at the time when power is supplied. The states of internal circuits in the LSI are indeterminate and the states of register settings and pins are undefined at the time when power is supplied. In a finished product where the reset signal is applied to the external reset pin, the states of pins are not guaranteed from the time when power is supplied until the reset process is completed. In a similar way, the states of pins in a product that is reset by an on-chip power-on reset function are not guaranteed from the time when power is supplied until the power reaches the level at which resetting is specified.

3. Input of signal during power-off state

Do not input signals or an I/O pull-up power supply while the device is powered off. The current injection that results from input of such a signal or I/O pull-up power supply may cause malfunction and the abnormal current that passes in the device at this time may cause degradation of internal elements. Follow the guideline for input signal during power-off state as described in your product documentation.

4. Handling of unused pins

Handle unused pins in accordance with the directions given under handling of unused pins in the manual. The input pins of CMOS products are generally in the high-impedance state. In operation with an unused pin in the open-circuit state, extra electromagnetic noise is induced in the vicinity of the LSI, an associated shoot-through current flows internally, and malfunctions occur due to the false recognition of the pin state as an input signal become possible.

5. Clock signals

After applying a reset, only release the reset line after the operating clock signal becomes stable. When switching the clock signal during program execution, wait until the target clock signal is stabilized. When the clock signal is generated with an external resonator or from an external oscillator during a reset, ensure that the reset line is only released after full stabilization of the clock signal. Additionally, when switching to a clock signal produced with an external resonator or by an external oscillator while program execution is in progress, wait until the target clock signal is stable.

6. Voltage application waveform at input pin

Waveform distortion due to input noise or a reflected wave may cause malfunction. If the input of the CMOS device stays in the area between V_{IL} (Max.) and V_{IH} (Min.) due to noise, for example, the device may malfunction. Take care to prevent chattering noise from entering the device when the input level is fixed, and also in the transition period when the input level passes through the area between V_{IL} (Max.) and V_{IH} (Min.).

7. Prohibition of access to reserved addresses

Access to reserved addresses is prohibited. The reserved addresses are provided for possible future expansion of functions. Do not access these addresses as the correct operation of the LSI is not guaranteed.

8. Differences between products

Before changing from one product to another, for example to a product with a different part number, confirm that the change will not lead to problems. The characteristics of a microprocessing unit or microcontroller unit products in the same group but having a different part number might differ in terms of internal memory capacity, layout pattern, and other factors, which can affect the ranges of electrical characteristics, such as characteristic values, operating margins, immunity to noise, and amount of radiated noise. When changing to a product with a different part number, implement a system-evaluation test for the given product.

Notice

1. Descriptions of circuits, software and other related information in this document are provided only to illustrate the operation of semiconductor products and application examples. You are fully responsible for the incorporation or any other use of the circuits, software, and information in the design of your product or system. Renesas Electronics disclaims any and all liability for any losses and damages incurred by you or third parties arising from the use of these circuits, software, or information.
2. Renesas Electronics hereby expressly disclaims any warranties against and liability for infringement or any other claims involving patents, copyrights, or other intellectual property rights of third parties, by or arising from the use of Renesas Electronics products or technical information described in this document, including but not limited to, the product data, drawings, charts, programs, algorithms, and application examples.
3. No license, express, implied or otherwise, is granted hereby under any patents, copyrights or other intellectual property rights of Renesas Electronics or others.
4. You shall be responsible for determining what licenses are required from any third parties, and obtaining such licenses for the lawful import, export, manufacture, sales, utilization, distribution or other disposal of any products incorporating Renesas Electronics products, if required.
5. You shall not alter, modify, copy, or reverse engineer any Renesas Electronics product, whether in whole or in part. Renesas Electronics disclaims any and all liability for any losses or damages incurred by you or third parties arising from such alteration, modification, copying or reverse engineering.
6. Renesas Electronics products are classified according to the following two quality grades: "Standard" and "High Quality". The intended applications for each Renesas Electronics product depends on the product's quality grade, as indicated below.
 - "Standard": Computers; office equipment; communications equipment; test and measurement equipment; audio and visual equipment; home electronic appliances; machine tools; personal electronic equipment; industrial robots; etc.
 - "High Quality": Transportation equipment (automobiles, trains, ships, etc.); traffic control (traffic lights); large-scale communication equipment; key financial terminal systems; safety control equipment; etc.

Unless expressly designated as a high reliability product or a product for harsh environments in a Renesas Electronics data sheet or other Renesas Electronics document, Renesas Electronics products are not intended or authorized for use in products or systems that may pose a direct threat to human life or bodily injury (artificial life support devices or systems; surgical implantations; etc.), or may cause serious property damage (space system; undersea repeaters; nuclear power control systems; aircraft control systems; key plant systems; military equipment; etc.). Renesas Electronics disclaims any and all liability for any damages or losses incurred by you or any third parties arising from the use of any Renesas Electronics product that is inconsistent with any Renesas Electronics data sheet, user's manual or other Renesas Electronics document.
7. No semiconductor product is absolutely secure. Notwithstanding any security measures or features that may be implemented in Renesas Electronics hardware or software products, Renesas Electronics shall have absolutely no liability arising out of any vulnerability or security breach, including but not limited to any unauthorized access to or use of a Renesas Electronics product or a system that uses a Renesas Electronics product. RENESAS ELECTRONICS DOES NOT WARRANT OR GUARANTEE THAT RENESAS ELECTRONICS PRODUCTS, OR ANY SYSTEMS CREATED USING RENESAS ELECTRONICS PRODUCTS WILL BE INVULNERABLE OR FREE FROM CORRUPTION, ATTACK, VIRUSES, INTERFERENCE, HACKING, DATA LOSS OR THEFT, OR OTHER SECURITY INTRUSION ("Vulnerability Issues"). RENESAS ELECTRONICS DISCLAIMS ANY AND ALL RESPONSIBILITY OR LIABILITY ARISING FROM OR RELATED TO ANY VULNERABILITY ISSUES. FURTHERMORE, TO THE EXTENT PERMITTED BY APPLICABLE LAW, RENESAS ELECTRONICS DISCLAIMS ANY AND ALL WARRANTIES, EXPRESS OR IMPLIED, WITH RESPECT TO THIS DOCUMENT AND ANY RELATED OR ACCOMPANYING SOFTWARE OR HARDWARE, INCLUDING BUT NOT LIMITED TO THE IMPLIED WARRANTIES OF MERCHANTABILITY, OR FITNESS FOR A PARTICULAR PURPOSE.
8. When using Renesas Electronics products, refer to the latest product information (data sheets, user's manuals, application notes, "General Notes for Handling and Using Semiconductor Devices" in the reliability handbook, etc.), and ensure that usage conditions are within the ranges specified by Renesas Electronics with respect to maximum ratings, operating power supply voltage range, heat dissipation characteristics, installation, etc. Renesas Electronics disclaims any and all liability for any malfunctions, failure or accident arising out of the use of Renesas Electronics products outside of such specified ranges.
9. Although Renesas Electronics endeavors to improve the quality and reliability of Renesas Electronics products, semiconductor products have specific characteristics, such as the occurrence of failure at a certain rate and malfunctions under certain use conditions. Unless designated as a high reliability product or a product for harsh environments in a Renesas Electronics data sheet or other Renesas Electronics document, Renesas Electronics products are not subject to radiation resistance design. You are responsible for implementing safety measures to guard against the possibility of bodily injury, injury or damage caused by fire, and/or danger to the public in the event of a failure or malfunction of Renesas Electronics products, such as safety design for hardware and software, including but not limited to redundancy, fire control and malfunction prevention, appropriate treatment for aging degradation or any other appropriate measures. Because the evaluation of microcomputer software alone is very difficult and impractical, you are responsible for evaluating the safety of the final products or systems manufactured by you.
10. Please contact a Renesas Electronics sales office for details as to environmental matters such as the environmental compatibility of each Renesas Electronics product. You are responsible for carefully and sufficiently investigating applicable laws and regulations that regulate the inclusion or use of controlled substances, including without limitation, the EU RoHS Directive, and using Renesas Electronics products in compliance with all these applicable laws and regulations. Renesas Electronics disclaims any and all liability for damages or losses occurring as a result of your noncompliance with applicable laws and regulations.
11. Renesas Electronics products and technologies shall not be used for or incorporated into any products or systems whose manufacture, use, or sale is prohibited under any applicable domestic or foreign laws or regulations. You shall comply with any applicable export control laws and regulations promulgated and administered by the governments of any countries asserting jurisdiction over the parties or transactions.
12. It is the responsibility of the buyer or distributor of Renesas Electronics products, or any other party who distributes, disposes of, or otherwise sells or transfers the product to a third party, to notify such third party in advance of the contents and conditions set forth in this document.
13. This document shall not be reprinted, reproduced or duplicated in any form, in whole or in part, without prior written consent of Renesas Electronics.
14. Please contact a Renesas Electronics sales office if you have any questions regarding the information contained in this document or Renesas Electronics products.

(Note1) "Renesas Electronics" as used in this document means Renesas Electronics Corporation and also includes its directly or indirectly controlled subsidiaries.

(Note2) "Renesas Electronics product(s)" means any product developed or manufactured by or for Renesas Electronics.

(Rev.5.0-1 October 2020)

Corporate Headquarters

TOYOSU FORESIA, 3-2-24 Toyosu,
Koto-ku, Tokyo 135-0061, Japan
www.renesas.com

Trademarks

Semtech, the Semtech logo, LoRa, LoRaWAN and LoRa Alliance are registered trademarks or service marks, or trademarks or service marks, of Semtech Corporation and/or its affiliates. Renesas and the Renesas logo are trademarks of Renesas Electronics Corporation. All trademarks and registered trademarks are the property of their respective owners.

Contact information

For further information on a product, technology, the most up-to-date version of a document, or your nearest sales office, please visit:
www.renesas.com/contact/.