

## FT Router 5000



Build high performance half routers that increase the scalability and surviveability of LONWORKS® control networks while lowering the overall solution cost.



### FT Router 5000 Key Features

- 3.3V operation
- Higher-performance Neuron® Core; internal system clock scales up to 40 MHz; Larger buffer size to allow for extended-NVs and improved throughput
- Serial interface for inexpensive-external non-volatile EEPROM and flash memories
- Compliant with TP/FT-10 Channels
- Low-cost surface mount FT-X3 Communications Transformer
- Compact 7mm x 7mm 48-pin QFN package
- Logical Isolation between two half routers improves system reliability by isolating failures between channels
- -40°C to +85°C operating temperature range

### Proven, Safe Choice

The FT Router 5000 IC is an Echelon semiconductor product that is used to build half routers and full routers. The FT Router 5000 IC is based on the Echelon FT 5000 Smart Transceiver and can be used to build a FT-10 channel halfrouter with LONWORKS® communication channel to route LonTalk® messages. An Echelon router can support installation of networks with up to thousands of nodes.

The FT Router 5000 IC includes the Router firmware required to implement a half router. Its compact form factor minimizes the space required to develop a half router. Customers can develop two half routers to build a full router. Customers will need to use the FT-X3 communications transformer to connect to the network. The Router parameters are stored in an external EEPROM with a minimum size of 2 KB. For a full router design, customers can use the same crystal and the same power supply to implement the clock needed for the two half routers. This offers the flexibility for customers to incorporate the FT Router 5000 IC into their design for a higher level of integration.

The FT Router 5000 IC can use one of four routing algorithms: configured router, learning router, bridge or repeater. The ability to choose these options allows the customer to trade off system performance for ease of installation.

Configured and learning routers fall into a class of routers known as intelligent routers, which use routing tables to selectively forward messages based on the destination address.

A router configured as a bridge forwards all valid packets that match its domains, whereas a router functioning as a repeater forwards all valid packets. Configured routers are easily installed using an installation tool such as the OpenLNS Commissioning Tool and OpenLNS network operating system that calculates network topology and layer 4 timing parameters.

### Usage

A FT Router 5000 based FT-10 channel half router consists of the FT Router 5000 chip, the FT-X3 communications transformer, a crystal to generate the clock and an external memory to hold the router table. Two such half routers are used to build a full router. A half router design that uses FT Router 5000 can be used with another half router to function as a repeater or interface with other twisted pair physical media such as RS-485, TP-78, TP-1250 or LPT-11. It can also be used to implement a FT-PL router using the PL 3150 Smart Transceiver. The two half routers of a full router are logically isolated so that a failure in one half router will not affect the other side's network.

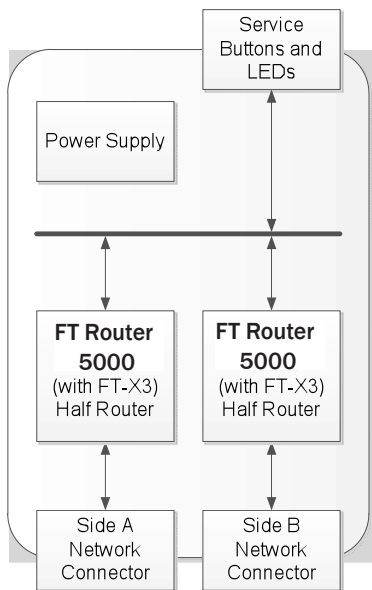

**Figure 1: Block Diagram of the LONWORKS Router based on the FT Router 5000**

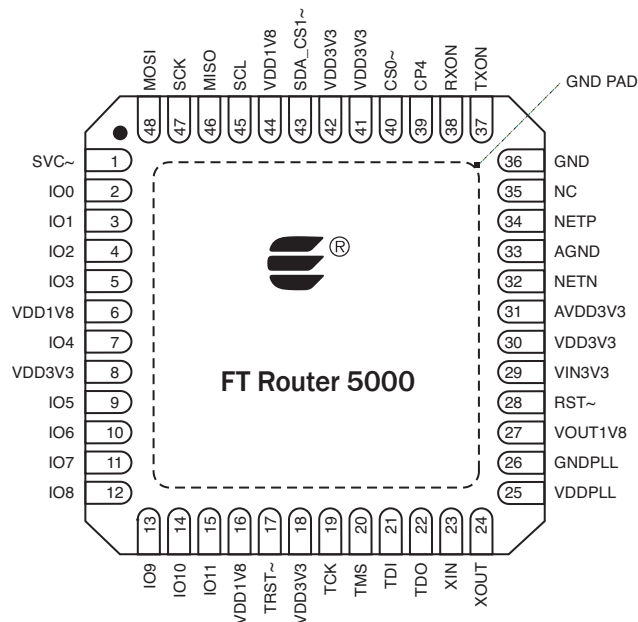

**Figure 2: FT Router 5000 Chip Pinout**

A FT Router 5000 IC based LONWORKS half router consists of the FT Router 5000 IC, the FT-X3 communications transformer, a crystal to generate the clock and an external serial memory to hold the router table. Two such half routers are used to build a full router. A half router design that uses FT Router 5000 can be used with a half router that uses the Router 5000 and an external transceiver such as RS-485, TP-1250, TP-78, FTT-10A or LPT-11 to implement a LONWORKS full router. The FT Router 5000 IC can also be used to implement the FT section of a FTPL router along with the PL 3150 Smart Transceiver to implement the PL section. Additionally, the FT Router 5000 IC offers higher reliability since two half routers of a full router are logically isolated and a failure in one half router will not affect the other side's network.

LONWORKS application programs do not have to be modified to work with routers. Only the network configuration of a device has to be modified when a device is moved to the far side of a router. The required modifications to the network configuration can be done automatically by an installation tool.

Routers are also independent of the network variables and message tags in a system, and can forward an unlimited number of them, which saves development cost because no code development is required to use routers in a system. It also saves installation and maintenance costs because router configuration is automatically managed by network server tools based on OpenLNS. Monitoring and control applications, such as those based on the LCA Object Server OCX, do not require modifications to work with multi-channel networks when routers are used. All network configuration is performed over the installed network, further minimizing installation and maintenance costs because routers do not have to be physically accessed to change their configuration.

**Table 1: FT Router 5000 Chip Pin Assignments**

Below is a table of the pin assignments for the FT Router 5000 chip. All digital inputs are low-voltage transistor-transistor logic (LVTTTL) compatible, 5 V tolerant, with low leakage. All digital inputs are low-voltage transistor-transistor logic (LVTTTL) compatible, low leakage, 5V-tolerant. All digital outputs are slew-rate limited to reduce Electromagnetic Interference (EMI).

Name	Pin Number	Type	Description
SVC~	1	Digital I/O	Service (active low)
IO0	2	Digital I/O	IO0 (side A to side B)
IO1	3	Digital I/O	IO1 (side A to side B)
IO2	4	Digital I/O	IO2 (side A to side B)
IO3	5	Digital I/O	IO3 (side A to side B)
VDD1V8	6	Power	1.8 V Power Input (from internal voltage regulator)
IO4	7	Digital I/O	IO4 (side A to side B)
VDD3V3	8	Power	3.3 V Power
IO5	9	Digital I/O	IO5 (side A to side B)
IO6	10	Digital I/O	IO6 (side A to side B)
IO7	11	Digital I/O	IO7 (side A to side B)
IO8	12	Digital I/O	IO8 (side A to side B)
IO9	13	Digital I/O	IO9 (side A to side B)
IO10	14	Digital I/O	IO10 (side A to side B)
IO11	15	Digital I/O	IO11 (not used for routers)
VDD1V8	16	Power	1.8 V Power Input (from internal voltage regulator)
TRST~	17	Digital Input	JTAG Test Reset (active low)
VDD3V3	18	Power	3.3 V Power
TCK	19	Digital Input	JTAG Test Clock
TMS	20	Digital Input	JTAG Test Mode Select
TDI	21	Digital Input	JTAG Test Data In
TDO	22	Digital Output	JTAG Test Data Out
XIN	23	Oscillator In	Crystal oscillator input
XOUT	24	Oscillator Out	Crystal oscillator output
VDDPLL	25	Power	1.8 V Power Input (from internal voltage regulator)
GNDPLL	26	Power	Ground
VOUT1V8	27	Power	1.8 V Power Output (of internal voltage regulator)
RST~	28	Digital I/O	Reset (active low)

VIN3V3	29	Power	3.3 V Power Input
VDD3V3	30	Power	3.3 V Power
AVDD3V3	31	Power	3.3 V Power
NETN	32	Comm	Network Port (polarity insensitive)
AGND	33	Ground	Ground
NETP	34	Comm	Network Port (polarity insensitive)
NC	35	N/A	Do Not Connect
GND	36	Ground	Ground
TXON	37	Comm	TxActive for optional network activity LED
RXON	38	Comm	RxActive for optional network activity LED
CP4	39	Comm	Connect to VDD33 through a 4.99 kΩ pullup resistor
CS0-	40	Digital I/O for Memory	SPI slave select 0 (active low)
VDD3V3	41	Power	3.3 V Power
VDD3V3	42	Power	3.3 V Power
SDA_CS1-	43	Digital I/O for Memory	I <sup>2</sup> C: serial data SPI: slave select 1 (active low)
VDD1V8	44	Power	1.8 V Power Input (from internal voltage regulator)
SCL	45	Digital I/O for Memory	I <sup>2</sup> C serial clock
MISO	46	Digital I/O for Memory	SPI master input, slave output (MISO)
SCK	47	Digital I/O for Memory	SPI serial clock
MOSI	48	Digital I/O for Memory	SPI master output, slave input (MOSI)
PAD	49	Ground Pad	Ground

Parameter <sup>1</sup>	Description	Minimum	Typical	Maximum
V <sub>DD3</sub>	Supply voltage	3.00 V	3.3 V	3.60 V
V <sub>LVI</sub>	Low-voltage indicator trip point	2.70 V		2.96 V
T <sub>A</sub>	Ambient temperature	-40° C		+85° C
f <sub>XIN</sub>	XIN clock frequency <sup>2</sup>	-	10,000 MHz	-
I <sub>DD3-RX</sub>	Current consumption in receive mode <sup>3</sup>			
	5MHz		9 mA	15 mA
	10MHz		9 mA	15 mA
	20MHz		15 mA	23 mA
	40MHz		23 mA	33 mA
I <sub>DD3-TX</sub>	Current consumption in transmit mode <sup>3,4</sup>		I <sub>DD3-RX</sub> + 15 mA	I <sub>DD3-RX</sub> + 18 mA
	80MHz		38 mA	52 mA

**Table 2: Electrical Characteristics FT Router 5000 Operating Conditions**

**Notes**

- All parameters assume nominal supply voltage (V<sub>DD3</sub> = 3.3 V ± 0.3 V) and operating temperature (T<sub>A</sub> between -40°C and +85°C), unless otherwise noted.
- See Clock Requirements in the Series 5000 Chip Data Book for more detailed information about the XIN clock frequency.
- Assumes no load on digital I/O pins, and that the I/O lines are not switching.
- Current consumption in Transmit mode represents a peak value rather than a continuous usage value because a Series 5000 device does not typically transmit data continuously.

**Recommended FT Router 5000 Pad Layout**

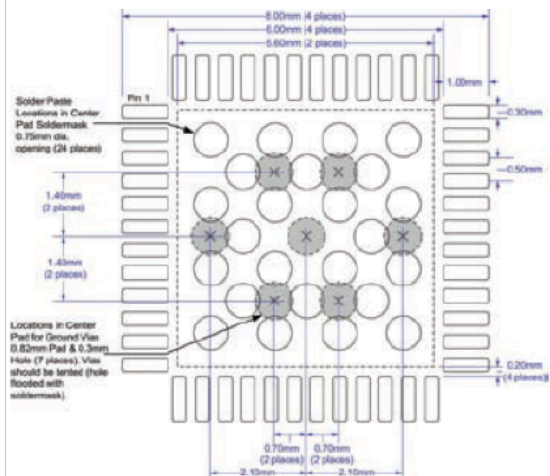

**Figure 3: Recommended FT Router 5000 Pad Layout**

**FT Router 5000 IC Mechanical Specification**

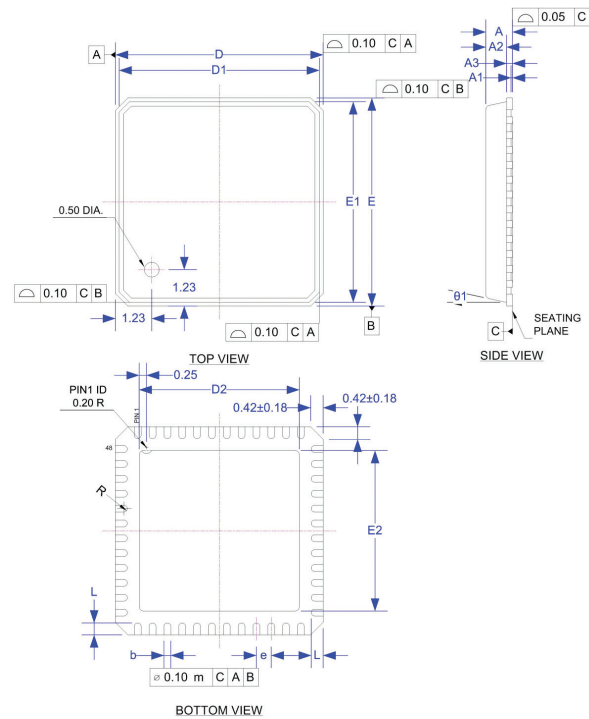

Pin Name	Pin Number	Description
NETP	1	NETP connection from FT 5000 Smart Transceiver
CTP1	2	Center tap primary 1
CTS2	3	Center tap secondary 2
NETA	4	NETA connection to LonWorks network
CTP2	5	Center tap primary 2
NETN	6	NETN connection from FT 5000 Smart Transceiver
NETB	7	NETB connection to LonWorks network
CTS1	8	Center tap secondary 1

**Table 3: FT-X3 Communications Transformer Pin Assignments**

\* CONTROLLING DIMENSION : MM

SYMBOL	MILLIMETER			INCH		
	MIN.	NOM.	MAX.	MIN.	NOM.	MAX.
A	---	---	0.90	---	---	0.035
A1	0.00	0.01	0.05	0.00	0.0004	0.002
A2	---	0.65	0.70	---	0.026	0.028
A3	0.20 REF.			0.008 REF.		
b	0.18	0.23	0.30	0.007	0.009	0.012
D	7.00 bsc			0.276 bsc		
D1	6.75 bsc			0.266 bsc		
D2	5.20	5.40	5.60	0.205	0.213	0.220
E	7.00 bsc			0.276 bsc		
E1	6.75 bsc			0.266 bsc		
E2	5.20	5.40	5.60	0.205	0.213	0.220
L	0.30	0.40	0.50	0.012	0.016	0.020
e	0.50 bsc			0.020 bsc		
$\theta 1$	0°	---	12°	0°	---	12°
R	0.09	---	---	0.004	---	---
TOLERANCES OF FORM AND POSITION						
aaa	0.10			0.004		
bbb	0.10			0.004		
ccc	0.05			0.002		

Notes

1. All dimensions are in millimeters.
2. Dimensions and tolerances conform to ASME Y14.5M.-1994.
3. Package warpage max. 0.08 mm.
4. Package corners unless otherwise specified are  $R0.175 \pm 0.025$  mm.

**FT-X3 Communications Transformer Pin Descriptions**

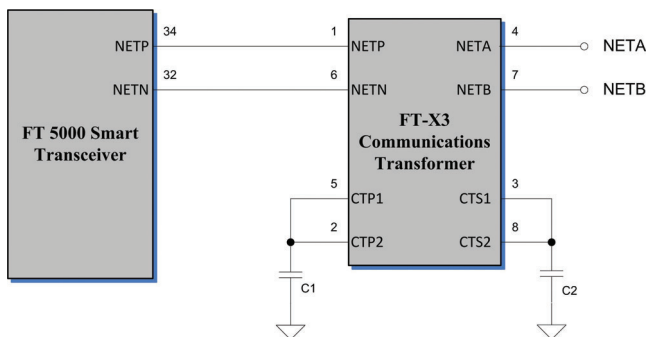

Figure 4: FT-X3 Communications Transformer Pinout Diagram

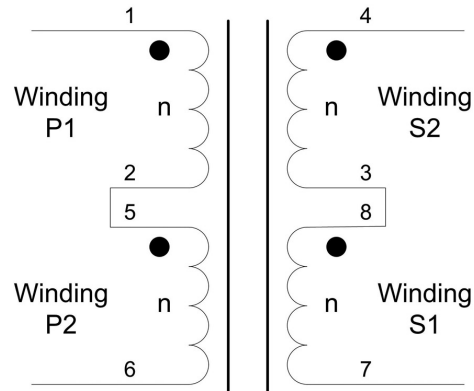

Figure 4: FT-X3 Communications Transformer Electrical Connection Schematic (winding connections are made on the PCB)

**Recommended FT-X3 Communications Transformer Pad Layout**

The FT-X3 Communications Transformer is rotationally symmetric. Hence, the transformer package does not have a marking for Pin 1.

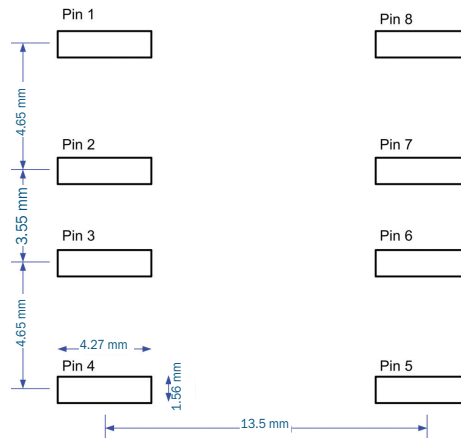
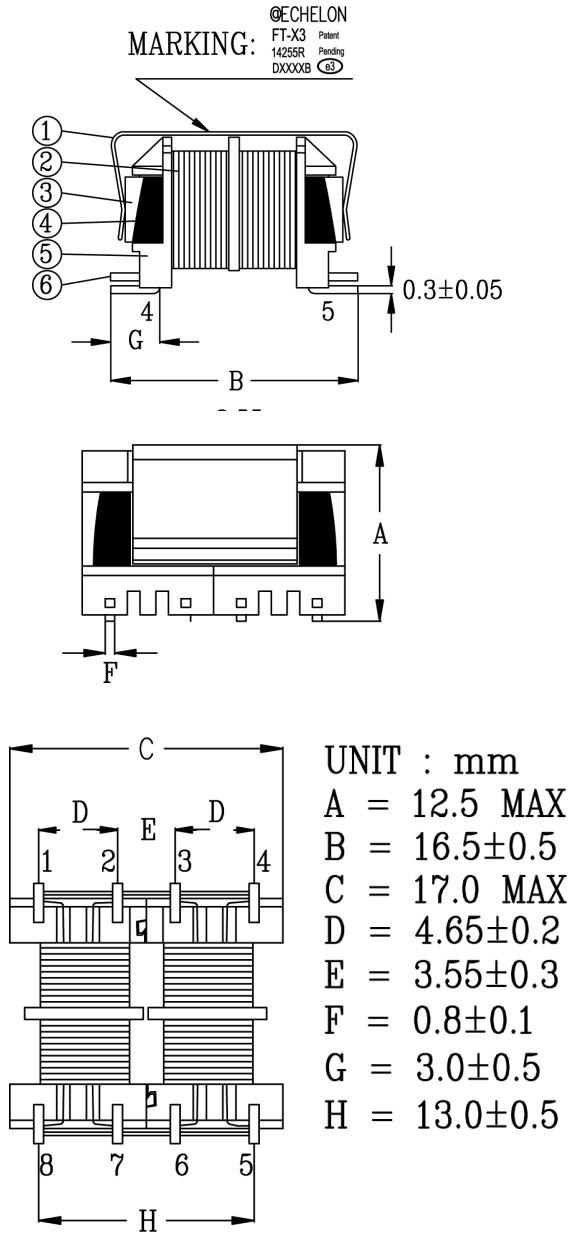

Figure 5: FT-X3 Transformer SMT Layout Pad Pattern

Recommendation: Add vias to the ends of each pin pad connection (just outside of the SMT pad rectangles) to provide additional mechanical support for the transformer.



# FT-X3 Communications Transformer Mechanical Specification



## FT-X3 Packing Specifications

Figure 8 shows the placement of each device on the carrier tape.

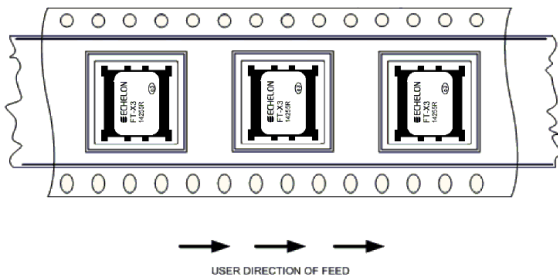

Figure 8: FT-X3 Device Placement on the Carrier Tape

## Figure 8 FT-X3 Packing Drawing

### Notes

1. Material: Black conductive polystyrene PS
2. Inspect per EIA-481-3 standard.
3. Tape thickness: 0.5±0.05 mm
4. 10 Sprocket hole pitch cumulative tolerance ±0.20
5. Carrier chamber is within 1 mm in 100 mm
6. Packing length per 22" reel: 10.2 meters
7. Packing length per 13" reel: 3.4 meters
8. Component load per 13" reel: 100 PCS
9. Compression strength: 1.5 kgf min.
10. Environment-Related substance must meet DELTA's general spec no. 10000-0162

Figure 9 shows the 1.3" Reels/4" Hub.

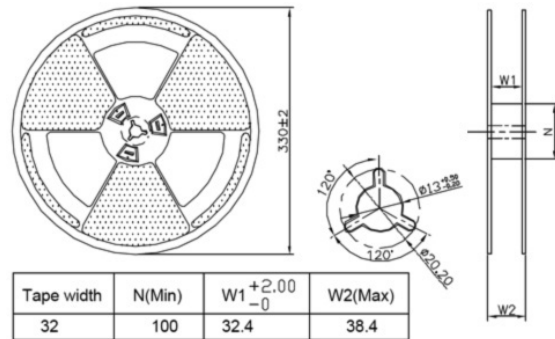
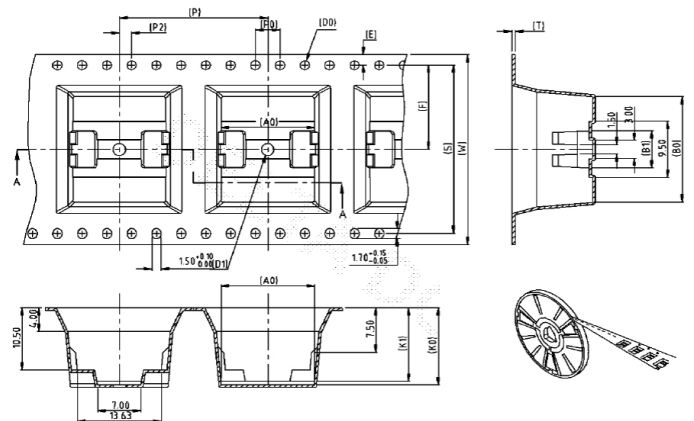

Figure 9: FT-X3 Reel and Hub Drawing

### Notes

1. All dimensions are in millimeters.
2. Tolerances unless noted: 1PL + ; 2PL + 0.2; 3PL + 0.1; ANG + 0.5"; FRACT +

Figure 21 shows the FT-X3 Packing Specification



### SECTION:A-A

W	32.00±0.30	P	24.00±0.10	AO	15.10±0.10	BO	17.80±0.15
S	28.40±0.10	P0	4.00±0.10			B1	6.30±0.10
E	1.75±0.10	P2	2.00±0.10				
F	14.20±0.10	DO	1.50±0.10	KO	13.00±0.10		
T	0.50±0.04	D1	2.00 MIN	K1	12.40±0.10		COLOR : BK/ANT

## Specifications

### Data Communications Type

Differential Manchester encoding

### Network Polarity

Polarity insensitive

### Isolation between Network and FT 5000 Router IC

0-60Hz, 60 seconds: 1,000Vrms; 0-60Hz, continuous: 277Vrms<sup>1</sup>

### EMI

Designed to comply with FCC Part 15 Level B and EN55022 Level B

### ESD

Designed to comply with EN 61000-4-2, Level 4

### Radiated Electromagnetic Susceptibility

Designed to comply with EN 61000-4-3, Level 3

### Fast Transient/Burst Immunity

Designed to comply with EN 61000-4-4, Level 4

### Surge Immunity

Designed to comply with EN 61000-4-5, Level 3

### Conducted RF Immunity

Designed to comply with EN 61000-4-6, Level 3

### Transmission Speed

78 kilobits per second

### Network Wiring

24 to 16AWG twisted pair; see Series 5000 Chip Data Book or Junction Box and Wiring Guidelines engineering bulletin for qualified cable types

### Network Length in Free Topology

500m (1,640 feet) maximum total wire with no repeaters. 500m (1,640 feet) maximum device-to-device distance.

### Network Length in Doubly-terminated Bus Topology

22700m (8,850 feet) with no repeaters

### Maximum Stub Length in Doubly-terminated Bus Topology

3m (9.8 feet)

### Network Termination

One terminator in free topology; two terminators in bus topology (more details in Series 5000 Chip Data Book).

### Power-down Network Protection

High impedance when unpowered.

### Operating Temperature

-40 to 85 °C

### Operating Humidity

25-90% RH @50 °C, non-condensing

### Non-operating Humidity

95% RH @ 50 °C, non-condensing

### Vibration

1.5g peak-to-peak, 8Hz-2kHz

### Mechanical Shock

100g (peak)  
(FT-X3 Communications Transformer)

### Reflow Soldering Temperature Profile

Refer to Joint Industry Standard document IPC/JEDEC J-STD-020D.1 (March 2008).

### Peak Reflow Soldering Temperature

260°C (FT 5000 Router)  
245°C (FT-X3 Communications Transformer)

### Co-planarity

0.12 mm (FT-X3 Communications Transformer)

### Mass

6 g (FT-X3 Communications Transformer)

## Notes

1. Safety agency hazardous voltage barrier requirements are not supported.
2. Network segment length varies, depending on wire type. See Junction Box and Wiring Guidelines engineering bulletin for detailed specifications.

## Ordering Information

FT Router 5000 14285R-100

FT-X3 Communications Transformer 14255R-400

## IMPORTANT NOTICE AND DISCLAIMER

RENESAS ELECTRONICS CORPORATION AND ITS SUBSIDIARIES (“RENESAS”) PROVIDES TECHNICAL SPECIFICATIONS AND RELIABILITY DATA (INCLUDING DATASHEETS), DESIGN RESOURCES (INCLUDING REFERENCE DESIGNS), APPLICATION OR OTHER DESIGN ADVICE, WEB TOOLS, SAFETY INFORMATION, AND OTHER RESOURCES “AS IS” AND WITH ALL FAULTS, AND DISCLAIMS ALL WARRANTIES, EXPRESS OR IMPLIED, INCLUDING, WITHOUT LIMITATION, ANY IMPLIED WARRANTIES OF MERCHANTABILITY, FITNESS FOR A PARTICULAR PURPOSE, OR NON-INFRINGEMENT OF THIRD-PARTY INTELLECTUAL PROPERTY RIGHTS.

These resources are intended for developers who are designing with Renesas products. You are solely responsible for (1) selecting the appropriate products for your application, (2) designing, validating, and testing your application, and (3) ensuring your application meets applicable standards, and any other safety, security, or other requirements. These resources are subject to change without notice. Renesas grants you permission to use these resources only to develop an application that uses Renesas products. Other reproduction or use of these resources is strictly prohibited. No license is granted to any other Renesas intellectual property or to any third-party intellectual property. Renesas disclaims responsibility for, and you will fully indemnify Renesas and its representatives against, any claims, damages, costs, losses, or liabilities arising from your use of these resources. Renesas' products are provided only subject to Renesas' Terms and Conditions of Sale or other applicable terms agreed to in writing. No use of any Renesas resources expands or otherwise alters any applicable warranties or warranty disclaimers for these products.

(Disclaimer Rev.1.01 Jan 2024)

### Corporate Headquarters

TOYOSU FORESIA, 3-2-24 Toyosu,  
Koto-ku, Tokyo 135-0061, Japan  
[www.renesas.com](http://www.renesas.com)

### Trademarks

Renesas and the Renesas logo are trademarks of Renesas Electronics Corporation. All trademarks and registered trademarks are the property of their respective owners.

### Contact Information

For further information on a product, technology, the most up-to-date version of a document, or your nearest sales office, please visit [www.renesas.com/contact-us/](http://www.renesas.com/contact-us/).