

ISL78200

2.5A Regulator with Integrated High-Side MOSFET for Synchronous Buck or Boost Buck Converter

FN7641
Rev 2.00
December 24, 2013

The ISL78200 is a synchronous buck controller with a 90mΩ high-side MOSFET and low-side driver integrated. The ISL78200 supports wide input range of 3V to 40V in buck mode. It supports 2.5A continuous load under conditions of 5V V_{OUT} , V_{IN} range of 8V to 36V, 500kHz and +85°C ambient temperature with still air. For any specific application, the actual maximum output current depends upon the die temperature not exceeding +125°C with the power dissipated in the IC, which is related to input voltage, output voltage, duty cycle, switching frequency, ambient temperature and board layout, etc. Refer to section “Output Current” on page 14 for more details.

The ISL78200 has flexible selection of operation modes of forced PWM mode and PFM mode. In PFM mode, the quiescent input current is as low as 300μA and can be further reduced to 180μA with AUXVCC connected to V_{OUT} under 12V V_{IN} and 5V V_{OUT} application. The load boundary between PFM and PWM can be programmed to cover wide applications.

The low-side driver can be either used to drive an external low-side MOSFET for a synchronous buck, or left unused for a standard non-synchronous buck. The low-side driver can also be used to drive a boost converter as a pre-regulator that greatly expands the operating input voltage range down to 2.5V or lower (refer to “Typical Application Schematic III - Boost Buck Converters” on page 5).

The ISL78200 offers the most robust current protections. It uses peak current mode control with cycle-by-cycle current limiting. It is implemented with frequency foldback under current limit condition; in addition, the hiccup overcurrent mode is also implemented to guarantee reliable operations under harsh short conditions.

The ISL78200 has comprehensive protections against various faults including overvoltage and over-temperature protections, etc.

Features

- Buck Mode: Input Voltage Range 3V to 40V (Refer to “Input Voltage” on page 14 for more details)
- Boost Mode Expands Operating Input Voltage Lower Than 2.5V (Refer to “Input Voltage” on page 14 for more details)
- Selectable Forced PWM Mode or PFM Mode
- 300μA IC Quiescent Current (PFM, No Load); 180μA Input Quiescent Current (PFM, No Load, V_{OUT} Connected to AUXVCC)
- Less than 3μA Shut Down Input Current (IC Disabled)
- Operational Topologies
 - Synchronous Buck
 - Non-Synchronous Buck
 - Two Stage Boost Buck
- Programmable Frequency from 200kHz - 2.2MHz and Frequency Synchronization Capability
- ±1% Tight Voltage Regulation Accuracy
- Reliable Cycle-by-Cycle Overcurrent Protection
 - Temperature Compensated Current Sense
 - Frequency Foldback
 - Programmable OC Limit
 - Hiccup Mode Protection in Worst Case Short Condition
- 20 Ld HTSSOP Package
- AEC Q100 Qualified
- Pb-Free (RoHS Compliant)

Applications

- Automotive Applications
- General Purpose Power Regulator
- 24V Bus Power
- Battery Power
- Embedded Processor and I/O Supplies

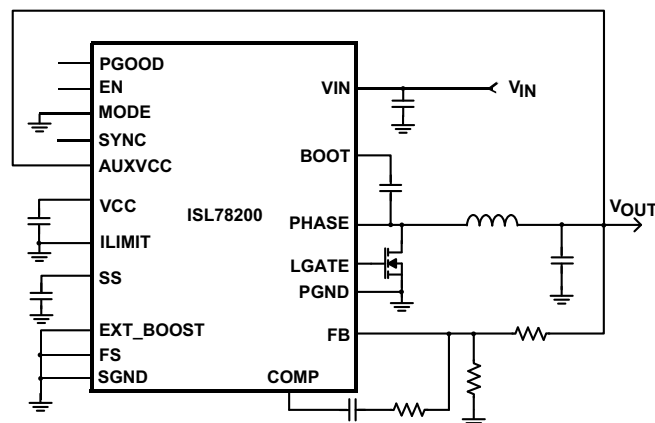

FIGURE 1. TYPICAL APPLICATION

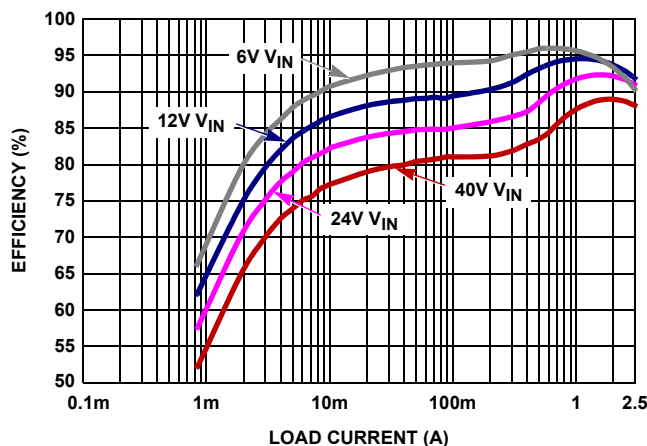
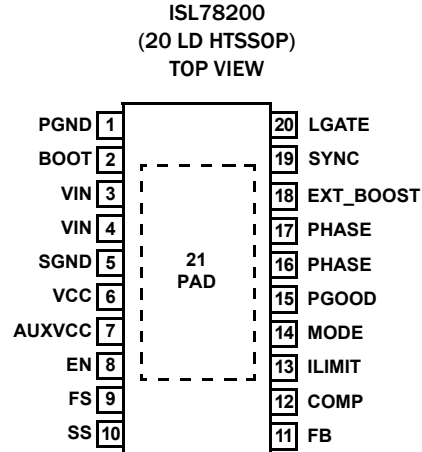

FIGURE 2. EFFICIENCY, SYNCHRONOUS BUCK, PFM MODE, V_{OUT} 5V, T_A = +25°C

Pin Configuration



Functional Pin Description

PIN NAME	PIN #	DESCRIPTION
PGND	1	This pin is used as the ground connection of the power flow including driver.
BOOT	2	This pin provides bias voltage to the high-side MOSFET driver. A bootstrap circuit is used to create a voltage suitable to drive the internal N-channel MOSFET. The boot charge circuitries are integrated inside of the IC. No external boot diode is needed. A 1 μ F ceramic capacitor is recommended to be used between BOOT and PHASE pin.
VIN	3, 4	Connect the input rail to these pins that are connected to the drain of the integrated high-side MOSFET, as well as the source for the internal linear regulator that provides the bias of the IC. Range: 3V to 40V. With the part switching, the operating input voltage applied to the VIN pins must be under 40V. This recommendation allows for short voltage ringing spikes (within a couple of ns time range) due to switching while not exceeding Absolute Maximum Ratings.
SGND	5	This pin provides the return path for the control and monitor portions of the IC.
VCC	6	This pin is the output of the internal linear regulator that supplies the bias for the IC including the driver. A minimum 4.7 μ F decoupling ceramic capacitor is recommended between VCC to ground.
AUXVCC	7	This pin is the input of the auxiliary internal linear regulator which can be supplied by the regulator output after power-up. With such a configuration, the power dissipation inside the IC is reduced. The input range for this LDO is 3V to 20V. In boost mode operation, this pin works as boost output overvoltage detection pin. It detects the boost output through a resistor divider. When voltage on this pin is above 0.8V, the boost PWM is disabled; and when voltage on this pin is below 0.8V minus the hysteresis, the boost PWM is enabled. Range: 3V to 20V.
EN	8	The controller is enabled when this pin is pulled HIGH or left floating. The IC is disabled when this pin is pulled LOW. Range: 0V to 5.5V.
FS	9	To connect this pin to VCC, or GND, or left open will force the IC to have 500kHz switching frequency. The oscillator switching frequency can also be programmed by adjusting the resistor from this pin to GND.
SS	10	Connect a capacitor from this pin to ground. This capacitor, along with an internal 5 μ A current source, sets the soft-start interval of the converter. Also this pin can be used to track a ramp on this pin.
FB	11	This pin is the inverting input of the voltage feedback error amplifier. With a properly selected resistor divider connected from V _{OUT} to FB, the output voltage can be set to any voltage between the input rail (reduced by maximum duty cycle and voltage drop) and the 0.8V reference. Loop compensation is achieved by connecting an RC network across COMP and FB. The FB pin is also monitored for overvoltage events.
COMP	12	Output of the voltage feedback error amplifier.
ILIMIT	13	Programmable current limit pin. With this pin connected to VCC pin, or to GND, or left open, the current limit threshold is set to default 3.6A; the current limit threshold can be programmed with a resistor from this pin to GND.
MODE	14	Mode selection pin. Pull this pin to GND for forced PWM mode; to have it floating or connected to VCC will enable PFM mode when the peak inductor current is below the default threshold of 700mA. The current boundary threshold between PFM and PWM can also be programmed with a resistor at this pin to ground. For more details on PFM Mode Operation refer to the "Functional Description" on page 13.
PGOOD	15	PGOOD is an open drain output that will be pulled low immediately under the events when the output is out of regulation (OV or UV) or EN pin pulled low. PGOOD is equipped with a fixed delay of 1000 cycles upon output power-up (V _O > 90%).

Functional Pin Description (Continued)

PIN NAME	PIN #	DESCRIPTION
PHASE	16, 17	These pins are the PHASE nodes that should be connected to the output inductor. These pins are connected to the source of the high-side N channel MOSFET.
EXT_BOOST	18	This pin is used to set boost mode and monitor the battery voltage that is the input of the boost converter. After VCC POR, the controller will detect the voltage on this pin, if voltage on this pin is below 200mV, the controller is set in synchronous/non-synchronous buck mode and latch in this state unless VCC is below the POR falling threshold; if the voltage on this pin after VCC POR is above 200mV, the controller is set in boost mode and latch in this state. In boost mode, this pin is used to monitor input voltage through a resistor divider. By setting the resistor divider, the high threshold and hysteresis can be programmed. When voltage on this pin is above 0.8V, the PWM output (LGATE) for the boost converter is disabled, and when voltage on this pin is below 0.8V minus the hysteresis, the boost PWM is enabled. In boost mode operation, PFM is disabled when boost PWM is enabled. Check Boost Mode Operation in the "Functional Description" on page 13 for more details.
SYNC	19	This pin can be used to synchronize two or more ISL78200 controllers. Multiple ISL78200 can be synchronized with their SYNC pins connected together. 180 degree phase shift is automatically generated between the master and slave ICs. The internal oscillator can also lock to an external frequency source applied on this pin with square pulse waveform (with frequency 10% higher than the IC's local frequency, and pulse width higher than 150ns). This pin should be left floating if not used. Range: 0V to 5.5V.
LGATE	20	In synchronous buck mode, this pin is used to drive the lower side MOSFET to improve efficiency. In non-synchronous buck when a diode is used as the bottom side power device, this pin should be connected to VCC before VCC start-up to have low-side driver (LGATE) disabled. In boost mode, it can be used to drive the boost power MOSFET. The boost control PWM is the same with the buck control PWM.
PAD	21	Bottom thermal pad. It is not connected to any electrical potential of the IC. In layout it must be connected to PCB ground copper plane with an area as large as possible to effectively reduce the thermal impedance.

Ordering Information

PART NUMBER (Notes 1, 2, 3)	PART MARKING	TEMP. RANGE (°C)	PACKAGE (Pb-Free)	PKG. DWG. #
ISL78200AVEZ	ISL78200 AVEZ	-40 to +105	20 Ld HTSSOP	MDP0048
ISL78200EVAL1Z	Evaluation Board			

NOTES:

1. Add "-T*" suffix for tape and reel. Please refer to [TB347](#) for details on reel specifications.
2. These Intersil Pb-free plastic packaged products employ special Pb-free material sets, molding compounds/die attach materials, and 100% matte tin plate plus anneal (e3 termination finish, which is RoHS compliant and compatible with both SnPb and Pb-free soldering operations). Intersil Pb-free products are MSL classified at Pb-free peak reflow temperatures that meet or exceed the Pb-free requirements of IPC/JEDEC J STD-020.
3. For Moisture Sensitivity Level (MSL), please see device information page for [ISL78200](#). For more information on MSL please see techbrief [TB363](#).

Block Diagram

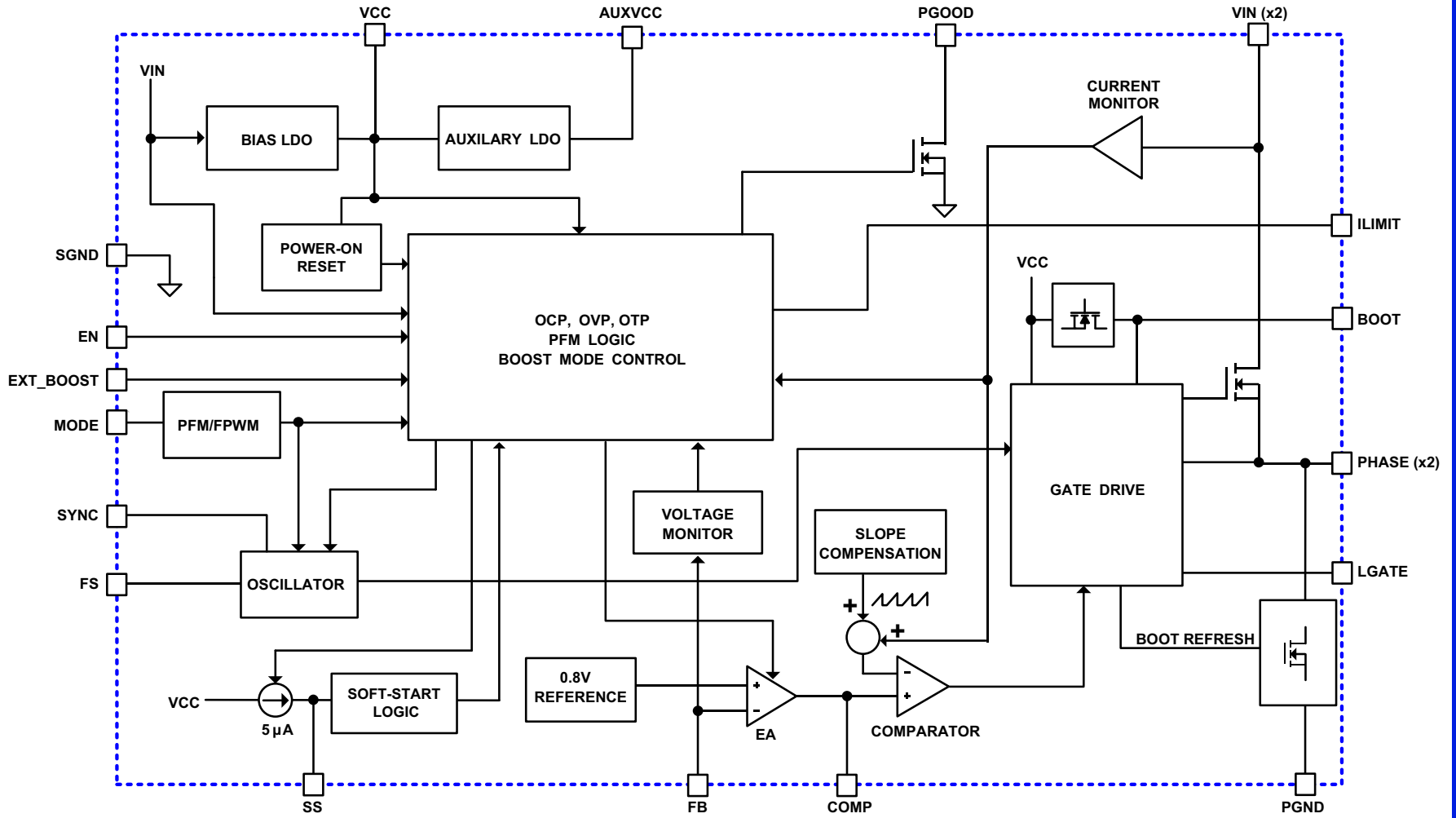

Typical Application Schematic I

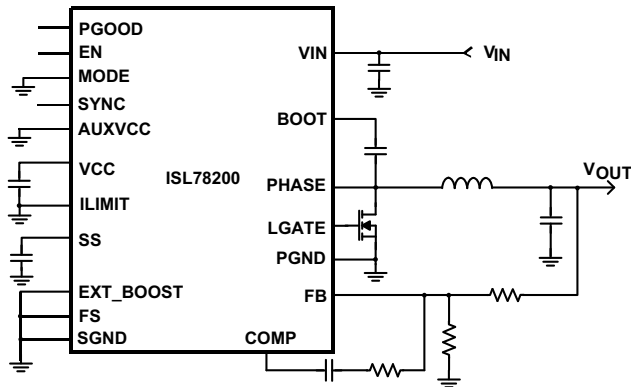

FIGURE 3A. SYNCHRONOUS BUCK

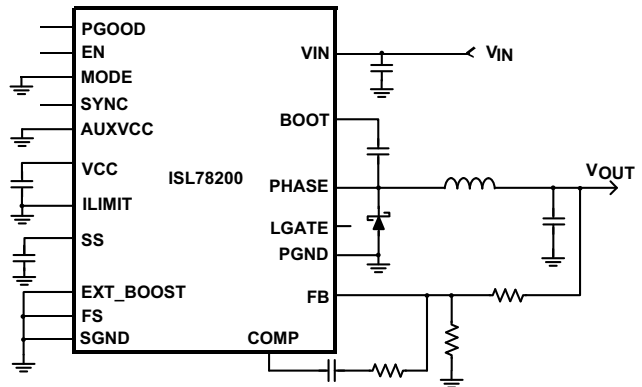

FIGURE 3B. NON-SYNCHRONOUS BUCK

Typical Application Schematic II - VCC Switch Over to VOUT

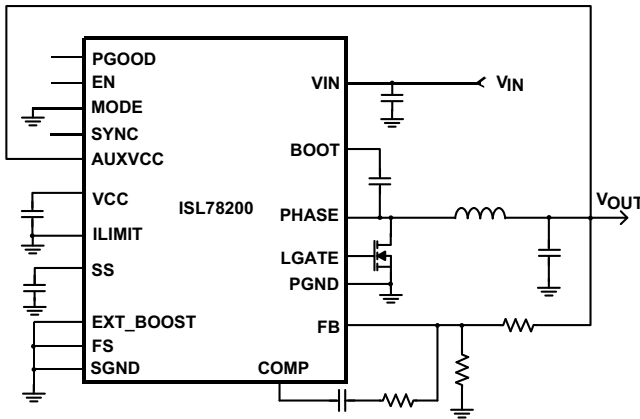

FIGURE 4A. SYNCHRONOUS BUCK

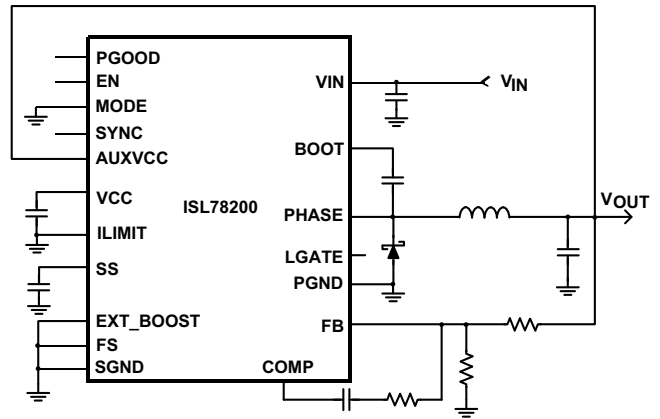
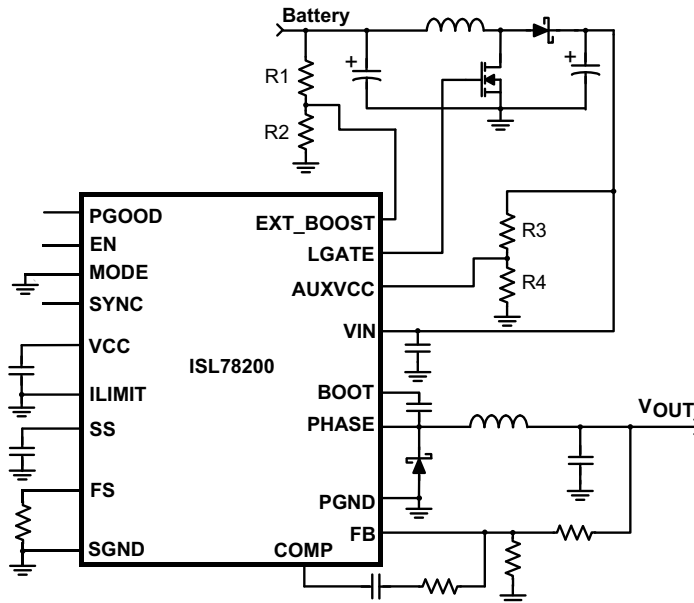

FIGURE 4B. NON-SYNCHRONOUS BUCK

Typical Application Schematic III - Boost Buck Converters



Absolute Maximum Ratings

VIN, PHASE	GND - 0.3V to +44V
VCC	GND - 0.3V to +6.0V
AUXVCC	GND - 0.3V to +22V
Absolute Boot Voltage, V _{BOOT}	+50.0V
Upper Driver Supply Voltage, V _{BOOT} - V _{PHASE}	+6.0V
All Other Pins	GND - 0.3V to VCC + 0.3V
ESD Rating	
Human Body Model (Tested per JESD22-A114F)	2000V
Machine Model (Tested per JESD22-A115C)	250V
Charged Device Model (Tested per JESD22-C101E)	1000V
Latchup Rating (Tested per JESD78B; Class II, Level A)	100mA

Thermal Information

Thermal Resistance	θ_{JA} (°C/W)	θ_{JC} (°C/W)
HTSSOP Package (Notes 4, 5)	35	3.5
Maximum Junction Temperature (Plastic Package)	+150°C	
Maximum Storage Temperature Range	-65°C to +150°C	
Pb-free Reflow Profile	see link below	
	http://www.intersil.com/pbfree/Pb-FreeReflow.asp	

Recommended Operating Conditions

Supply Voltage on VIN	3V to 40V
AUXVCC	GND - 0.3V to +20V
Ambient Temperature Range (Automotive)	-40°C to +105°C
Junction Temperature Range	-40°C to +125°C

CAUTION: Do not operate at or near the maximum ratings listed for extended periods of time. Exposure to such conditions may adversely impact product reliability and result in failures not covered by warranty.

NOTES:

- θ_{JA} is measured in free air with the component mounted on a high effective thermal conductivity test board with “direct attach” features. See Tech Brief [TB379](#).
- For θ_{JC} , the “case temp” location is the center of the exposed metal pad on the package underside.

Electrical Specifications Refer to the Block Diagram (page 4) and Typical Application Schematics (page 5). Operating conditions unless otherwise noted: V_{IN} = 12V, or V_{CC} = 4.5V, T_A = -40°C to +105°C. Typical values are at T_A = +25°C. **Boldface limits apply over the operating temperature range, -40°C to +105°C.**

PARAMETER	SYMBOL	TEST CONDITIONS	MIN (Note 6)	TYP	MAX (Note 6)	UNITS
V_{IN} SUPPLY						
V _{IN} Pin Voltage Range		V _{IN} Pin	3.05		40	V
		V _{IN} connected to VCC	3.05		5.5	V
Operating Supply Current	I _Q	MODE = VCC/FLOATING (PFM), no load at the output		300		μA
		MODE = GND (Forced PWM), V _{IN} = 12V, IC Operating, Not Including Driving Current		1.2		mA
ShutDown Supply Current	I _{IN_SD}	EN connected to GND, V _{IN} = 12V		1.8	3	μA
INTERNAL MAIN LINEAR REGULATOR						
MAIN LDO V _{CC} Voltage	V _{CC}	V _{IN} > 5V	4.2	4.5	4.8	V
MAIN LDO Dropout Voltage	V _{DROPOUT_MAIN}	V _{IN} = 4.2V, I _{VCC} = 35mA		0.3	0.5	V
		V _{IN} = 3V, I _{VCC} = 25mA		0.25	0.3	V
V _{CC} Current Limit of MAIN LDO				60		mA
INTERNAL AUXILIARY LINEAR REGULATOR						
AUXVCC Input Voltage Range	V _{AUXVCC}		3		20	V
AUX LDO V _{CC} Voltage	V _{CC}	V _{AUXVCC} > 5V	4.2	4.5	4.8	V
LDO Dropout Voltage	V _{DROPOUT_AUX}	V _{AUXVCC} = 4.2V, I _{VCC} = 35mA		0.3	0.5	V
		V _{AUXVCC} = 3V, I _{VCC} = 25mA		0.25	0.3	V
Current Limit of AUX LDO				60		mA
AUX LDO Switch-over Rising Threshold	V _{AUXVCC_RISE}	AUXVCC voltage rise, switch to auxiliary LDO	2.97	3.1	3.2	V
AUX LDO Switch-over Falling Threshold	V _{AUXVCC_FALL}	AUXVCC voltage fall, switch back to main BIAS LDO	2.73	2.87	2.97	V
AUX LDO Switch-over Hysteresis	V _{AUXVCC_HYS}	AUXVCC switch-over hysteresis		0.2		V

Electrical Specifications Refer to the Block Diagram (page 4) and Typical Application Schematics (page 5). Operating conditions unless otherwise noted: $V_{IN} = 12V$, or $V_{CC} = 4.5V$, $T_A = -40^\circ C$ to $+105^\circ C$. Typical values are at $T_A = +25^\circ C$. **Boldface limits apply over the operating temperature range, $-40^\circ C$ to $+105^\circ C$. (Continued)**

PARAMETER	SYMBOL	TEST CONDITIONS	MIN (Note 6)	TYP	MAX (Note 6)	UNITS
POWER-ON RESET						
Rising V_{CC} POR Threshold	V_{PORH_RISE}		2.82	2.9	3.05	V
Falling V_{CC} POR Threshold	V_{PORL_FALL}			2.6	2.8	V
V_{CC} POR Hysteresis	V_{PORL_HYS}			0.3		V
ENABLE						
Required Enable On Voltage	V_{ENH}		2			V
Required Enable Off Voltage	V_{ENL}				0.8	V
EN Pull Up Current	I_{EN_PULLUP}	$V_{IN} = 24V$		0.8		μA
		$V_{IN} = 12V$		0.5		μA
		$V_{IN} = 5V$		0.25		μA
OSCILLATOR						
PWM Frequency	F_{OSC}	$R_T = 665k\Omega$	160	200	240	kHz
		$R_T = 51.1k\Omega$	1950	2200	2450	kHz
		FS pin connected to VCC or floating or GND	450	500	550	kHz
MIN ON Time	t_{MIN_ON}			130	225	ns
MIN OFF Time	t_{MIN_OFF}			210	325	ns
SYNCHRONIZATION						
Input High Threshold	V_{IH}			2		V
Input Low Threshold	V_{IL}			0.5		V
Input Minimum Pulse Width				25		ns
Input Impedance				100		k Ω
Input Minimum Frequency Divided by Free Running Frequency				1.1		
Input Maximum Frequency Divided by Free Running Frequency				1.6		
Output Pulse Width		$C_{SYNC} = 100pF$		100		ns
Output Pulse High	V_{OH}	$R_{LOAD} = 1k\Omega$		VCC-0.25		V
Output Pulse Low	V_{OL}			GND		V
REFERENCE VOLTAGE						
Reference Voltage	V_{REF}			0.8		V
System Accuracy			-1.0		1.0	%
FB Pin Source Current				5		nA
SOFT-START						
Soft-Start Current	I_{SS}		3	5	7	μA
ERROR AMPLIFIER						
Unity Gain-Bandwidth		$C_{LOAD} = 50pF$		10		MHz
DC Gain		$C_{LOAD} = 50pF$		88		dB
Maximum Output Voltage				3.6		V

Electrical Specifications Refer to the Block Diagram (page 4) and Typical Application Schematics (page 5). Operating conditions unless otherwise noted: $V_{IN} = 12V$, or $V_{CC} = 4.5V$, $T_A = -40^\circ C$ to $+105^\circ C$. Typical values are at $T_A = +25^\circ C$. **Boldface limits apply over the operating temperature range, $-40^\circ C$ to $+105^\circ C$. (Continued)**

PARAMETER	SYMBOL	TEST CONDITIONS	MIN (Note 6)	TYP	MAX (Note 6)	UNITS
Minimum Output Voltage				0.5		V
Slew Rate	SR	$C_{LOAD} = 50pF$		5		V/ μs
PFM MODE CONTROL						
Default PFM Current Threshold		MODE = VCC or floating		700		mA
INTERNAL HIGH-SIDE MOSFET						
Upper MOSFET $r_{DS(ON)}$	$r_{DS(ON)_UP}$	(Note 7)		90	150	m Ω
LOW-SIDE MOSFET GATE DRIVER						
LGATE Source Resistance		100mA Source Current		3.5		Ω
LGATE Sink Resistance		100mA Sink Current		3.3		Ω
BOOST CONVERTER CONTROL						
EXT_BOOST Boost_Turn-Off Threshold Voltage			0.74	0.8	0.86	V
EXT_BOOST Hysteresis Sink Current	I_{AUXVCC_HYS}		2.4	3.2	3.8	μA
AUXVCC Boost Turn-Off Threshold Voltage			0.74	0.8	0.86	V
AUXVCC Hysteresis Sink Current	I_{AUXVCC_HYS}		2.4	3.2	3.8	μA
POWER GOOD MONITOR						
Overvoltage Rising Trip Point	V_{FB}/V_{REF}	Percentage of Reference Point	104	110	116	%
Overvoltage Rising Hysteresis	V_{FB}/V_{OVTRIP}	Percentage Below OV Trip Point		3		%
Undervoltage Falling Trip Point	V_{FB}/V_{REF}	Percentage of Reference Point	84	90	96	%
Undervoltage Falling Hysteresis	V_{FB}/V_{UVTRIP}	Percentage Above UV Trip Point		3		%
PGOOD Rising Delay	t_{PGOOD_DELAY}	$f_{OSC} = 500kHz$		2		ms
PGOOD Leakage Current		PGOOD HIGH, $V_{PGOOD} = 4.5V$		10		nA
PGOOD Low Voltage	V_{PGOOD}	PGOOD LOW, $I_{PGOOD} = 0.2mA$		0.10		V
PROTECTION						
Default Cycle by Cycle Current Limit Threshold	I_{OC_1}	ILIMIT = GND or VCC or Floating	3	3.6	4.2	A
Hiccup Current Limit Threshold	I_{OC_2}	Hiccup, I_{OC_2}/I_{OC_1}		115		%
OVERVOLTAGE PROTECTION						
OV Latching-off Trip Point		Percentage of Reference Point LG = UG = LATCH LOW		120		%
OV Non-Latching-off Trip Point		Percentage of Reference Point LG = UG = LOW		110		%
OV Non-Latching-off Release Point		Percentage of Reference Point		102.5		%
OVER-TEMPERATURE PROTECTION						
Over-Temperature Trip Point				155		$^\circ C$
Over-Temperature Recovery Threshold				140		$^\circ C$

NOTES:

- Parameters with MIN and/or MAX limits are 100% tested at $+25^\circ C$, unless otherwise specified. Temperature limits established by characterization and are not production tested.
- Wire bonds not included. The wire bond resistance between VIN and PHASE pin is 32m Ω typical.

Performance Curves

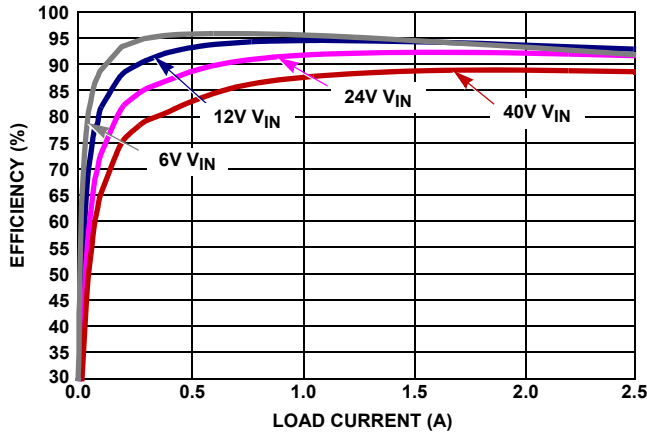

FIGURE 5. EFFICIENCY, SYNCHRONOUS BUCK, FORCED PWM MODE, 500kHz, V_{OUT} 5V, $T_A = +25^\circ C$

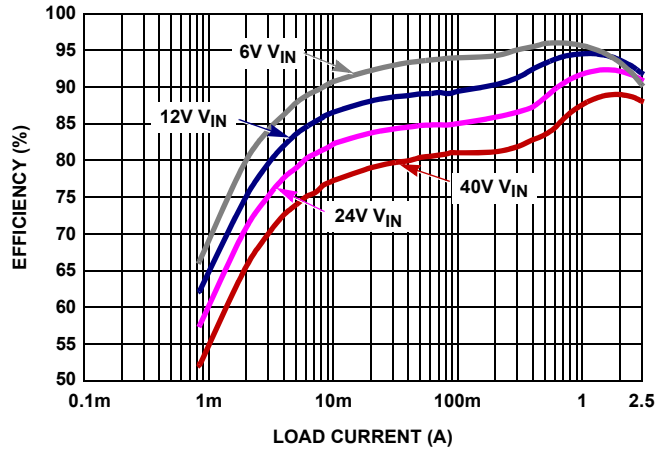

FIGURE 6. EFFICIENCY, SYNCHRONOUS BUCK, PFM MODE, V_{OUT} 5V, $T_A = +25^\circ C$

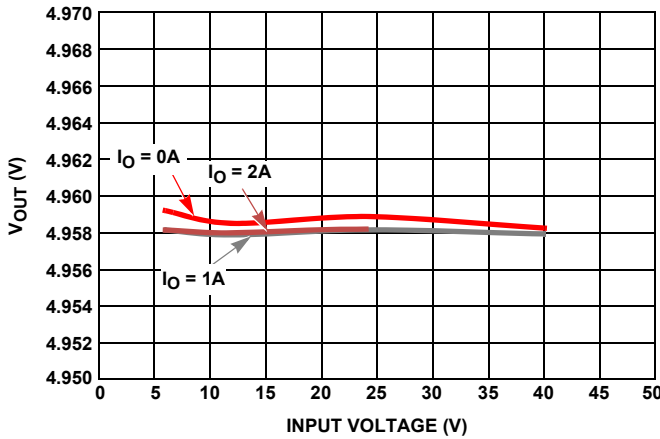

FIGURE 7. LINE REGULATION, V_{OUT} 5V, $T_A = +25^\circ C$

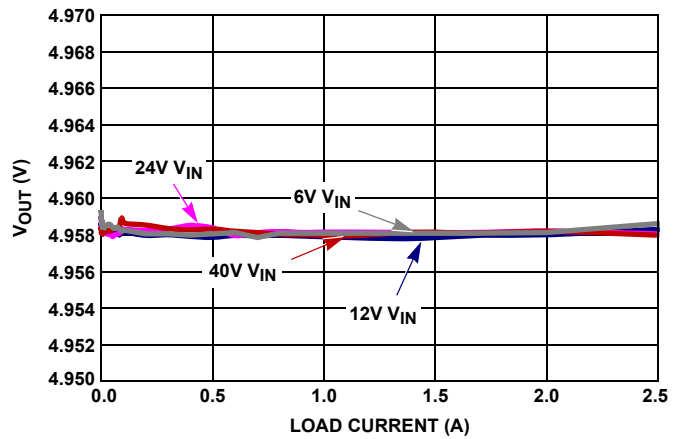

FIGURE 8. LOAD REGULATION, V_{OUT} 5V, $T_A = +25^\circ C$

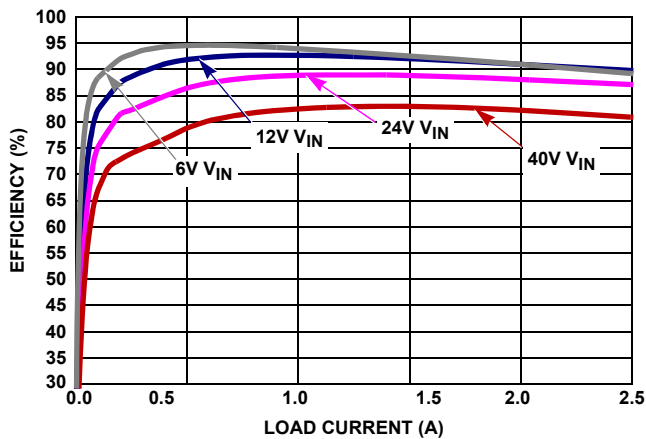

FIGURE 9. EFFICIENCY, SYNCHRONOUS BUCK, FORCED PWM MODE, 500kHz, V_{OUT} 3.3V, $T_A = +25^\circ C$

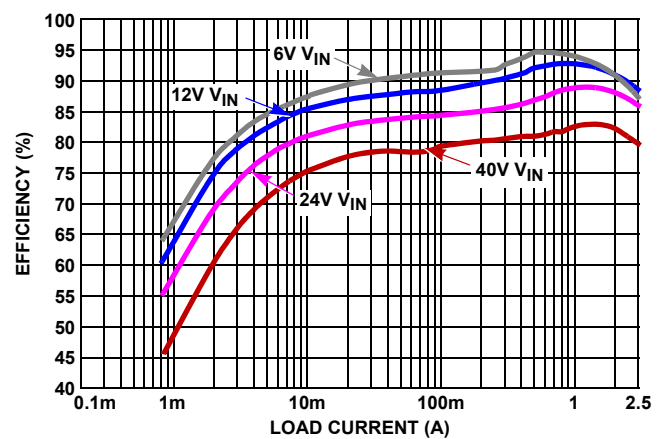

FIGURE 10. EFFICIENCY, SYNCHRONOUS BUCK, PFM MODE, V_{OUT} 3.3V, $T_A = +25^\circ C$

Performance Curves (Continued)

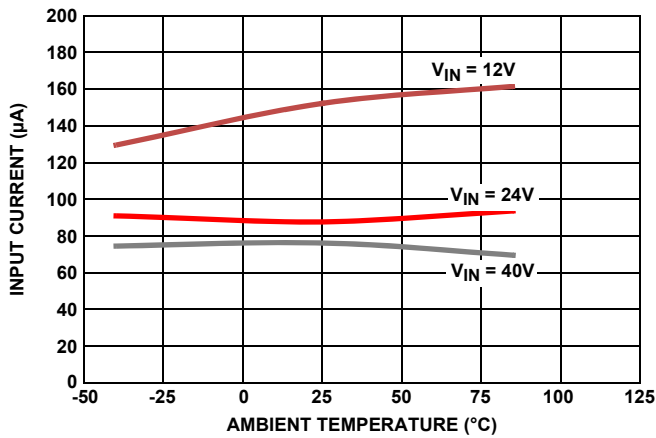

FIGURE 11. INPUT QUIESCENT CURRENT UNDER NO LOAD, PFM MODE, AUXVCC CONNECTED TO V_{OUT}, V_{OUT} = 5V

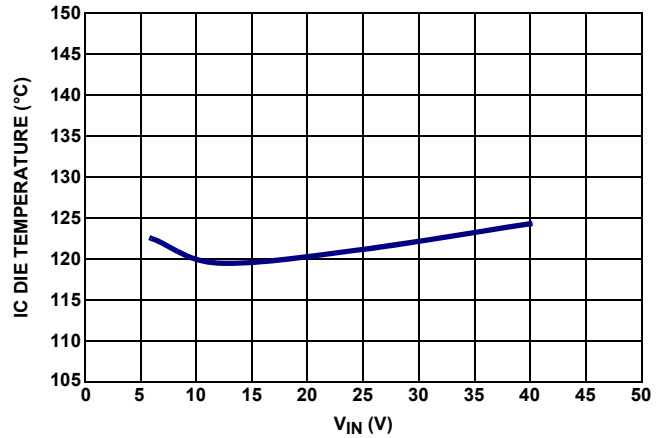

FIGURE 12. IC DIE TEMPERATURE UNDER +105°C AMBIENT TEMPERATURE, 100 CFM, 500kHz, V_{OUT} = 5V, I_O = 2A

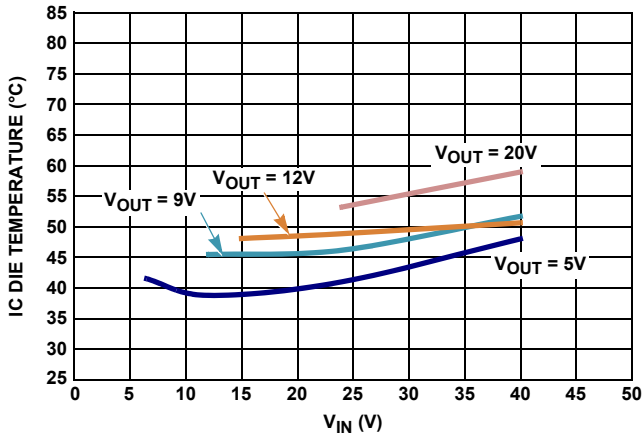

FIGURE 13. IC DIE TEMPERATURE UNDER +25°C AMBIENT TEMPERATURE, STILL AIR, 500kHz, I_O = 2A

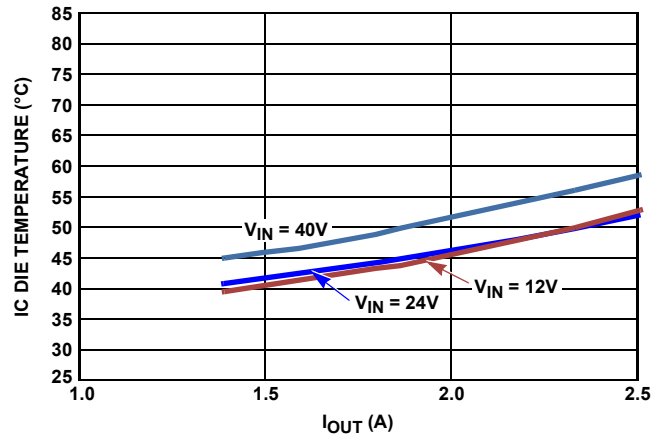

FIGURE 14. IC DIE TEMPERATURE UNDER +25°C AMBIENT TEMPERATURE, STILL AIR, 500kHz, V_{OUT} = 9V

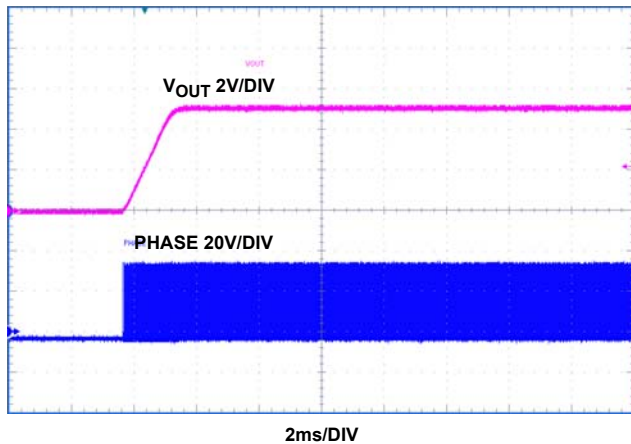

FIGURE 15. SYNCHRONOUS BUCK MODE, V_{IN} 36V, I_O 2A, ENABLE ON

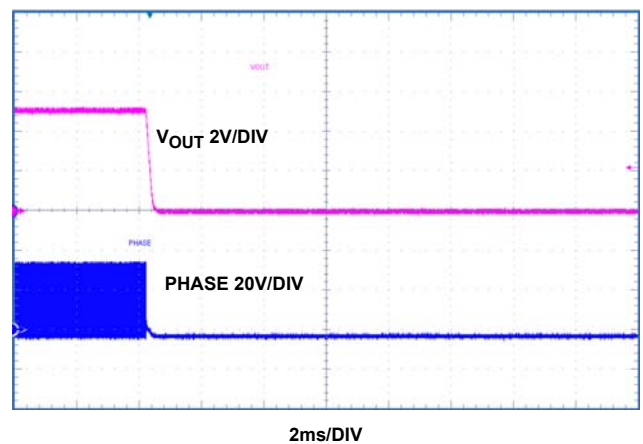

FIGURE 16. SYNCHRONOUS BUCK MODE, V_{IN} 36V, I_O 2A, ENABLE OFF

Performance Curves (Continued)

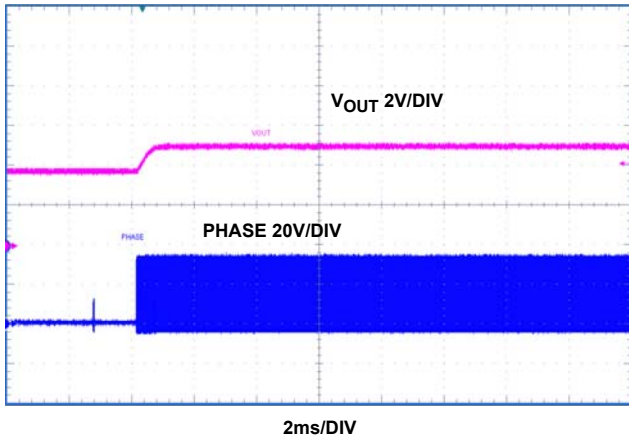

FIGURE 17. V_{IN} 36V, PREBIASED START-UP

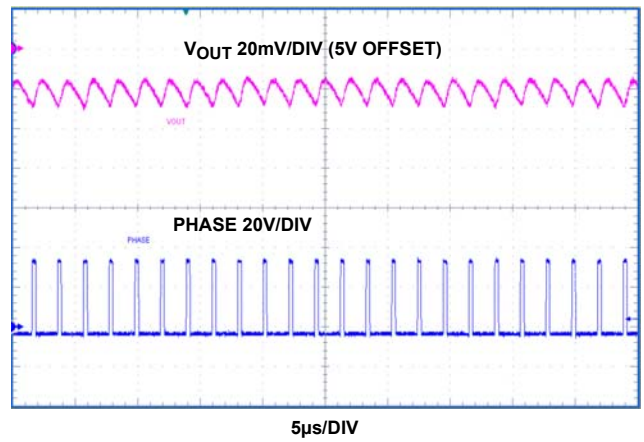

FIGURE 18. SYNCHRONOUS BUCK WITH FORCE PWM MODE, V_{IN} 36V, I_O 2A

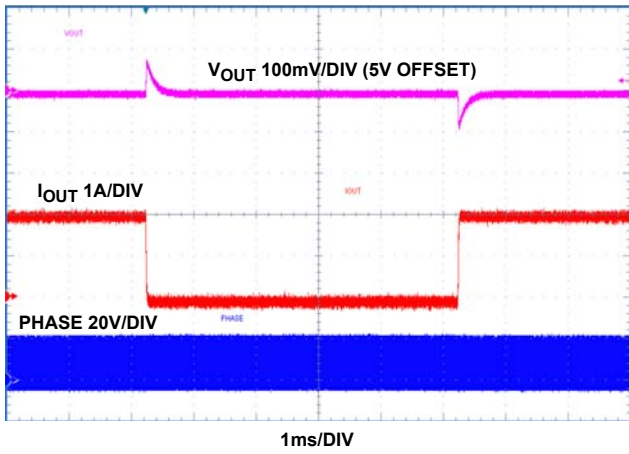

FIGURE 19. V_{IN} 24V, 0 TO 2A STEP LOAD, FORCE PWM MODE

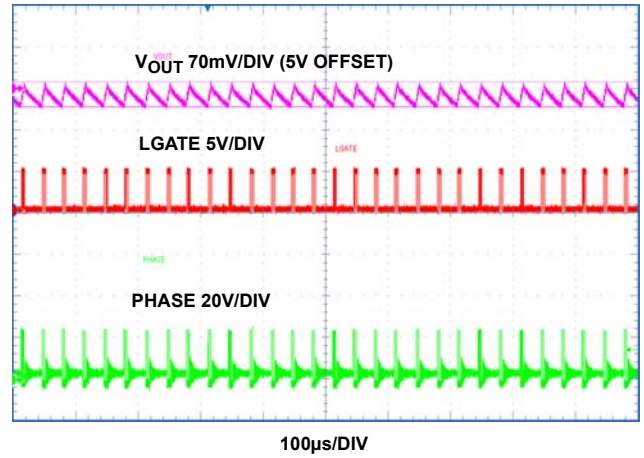

FIGURE 20. V_{IN} 24V, 80mA LOAD, PFM MODE

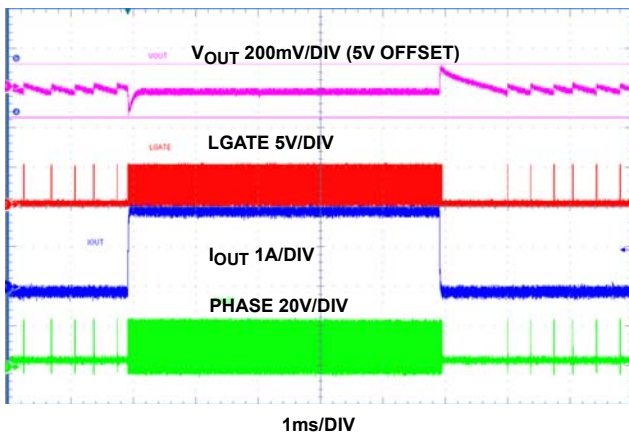

FIGURE 21. V_{IN} 24V, 0 TO 2A STEP LOAD, PFM MODE

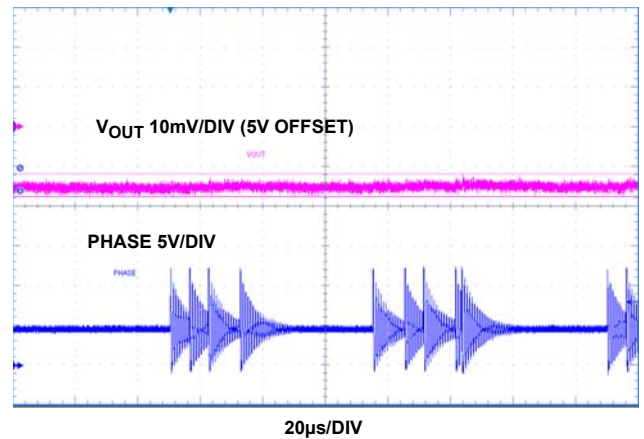

FIGURE 22. NON-SYNCHRONOUS BUCK, FORCE PWM MODE, V_{IN} 12V, NO LOAD

Performance Curves (Continued)

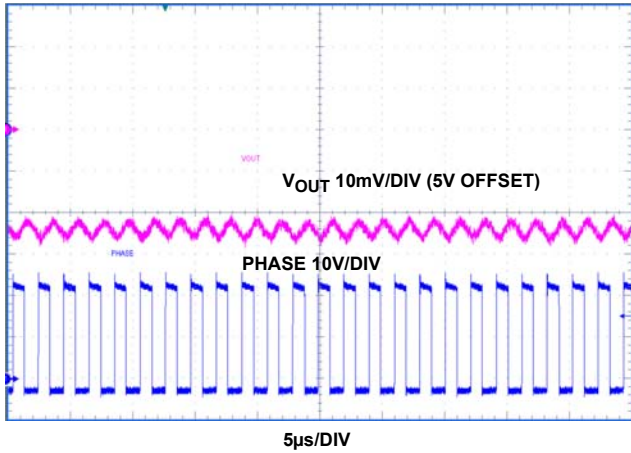

FIGURE 23. NON-SYNCHRONOUS BUCK, FORCE PWM MODE, V_{IN} 12V, 2A

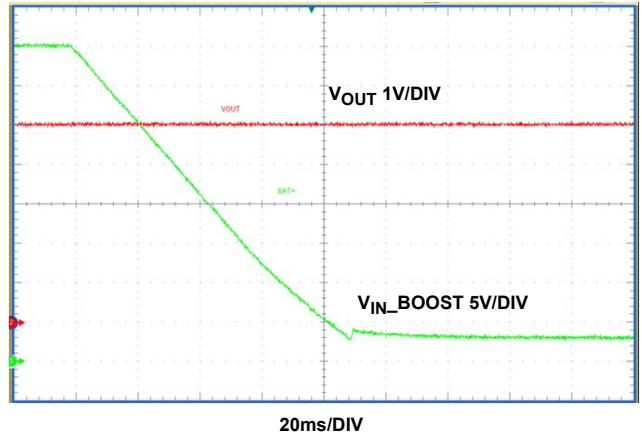

FIGURE 24. BOOST BUCK MODE, BOOST INPUT STEP FROM 40V TO 3V

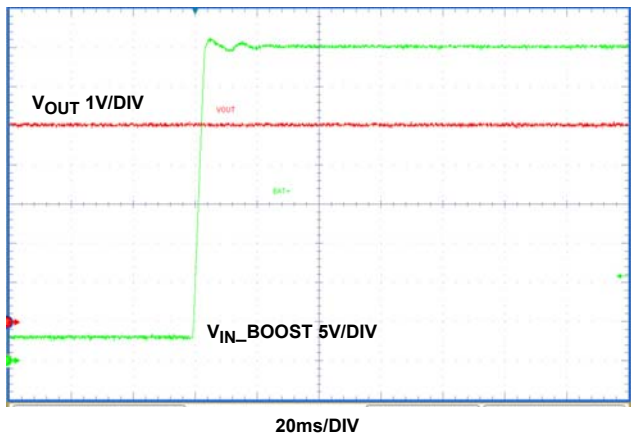

FIGURE 25. BOOST BUCK MODE, BOOST INPUT STEP FROM 3V TO 40V

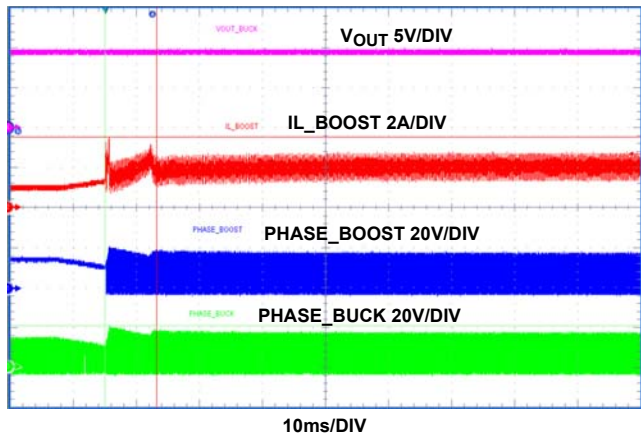

FIGURE 26. BOOST BUCK MODE, $V_O = 9V$, $I_O = 1.8A$, BOOST INPUT DROPS FROM 16V TO 9V DC

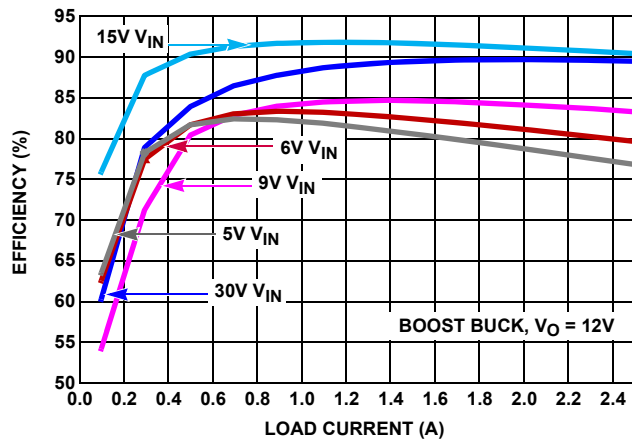

FIGURE 27. EFFICIENCY, BOOST BUCK, 500kHz, V_{OUT} 12V, $T_A = +25^\circ C$

Functional Description

Initialization

Initially, the ISL78200 continually monitors the voltage at EN pin. When the voltage on EN pin exceeds its rising threshold, the internal LDO will start-up to build up V_{CC} . After Power-On Reset (POR) circuits detect that V_{CC} voltage has exceeded the POR threshold, the soft-start will be initiated.

Soft-Start

The soft-start (SS) ramp is built up in the external capacitor on the SS pin that is charged by an internal 5 μ A current source.

$$C_{SS}[\mu\text{F}] = 6.5 \cdot t_{SS}[\text{S}] \quad (\text{EQ. 1})$$

The SS ramp starts from 0V to a voltage above 0.8V. Once SS reaches 0.8V, the bandgap reference takes over and the IC goes into steady state operation.

The SS plays a vital role in the hiccup mode of operation. The IC works as cycle-by-cycle peak current limiting at overload condition. When a harsh condition occurs and the current in the upper side MOSFET reaches the second overcurrent threshold, the SS pin is pulled to ground and a dummy soft-start cycle is initiated. At the dummy SS cycle, the current to charge the soft-start cap is cut down to 1/5 of its normal value. Therefore, a dummy SS cycle takes 5 times that of the regular SS cycle. During the dummy SS period, the control loop is disabled and no PWM output. At the end of this cycle, it will start the normal SS. The hiccup mode persists until the second overcurrent threshold is no longer reached.

The ISL78200 is capable of start-up with prebiased output.

PWM Control

Pulling the MODE pin to GND will set the IC in forced PWM mode. The ISL78200 employs the peak current mode PWM control for fast transient response and cycle-by-cycle current limiting. See “Block Diagram” on page 4.

The PWM operation is initialized by the clock from the oscillator. The upper MOSFET is turned on by the clock at the beginning of a PWM cycle and the current in the MOSFET starts to ramp up. When the sum of the current sense signal and the slope compensation signal reaches the error amplifier output voltage level, the PWM comparator is triggered to shut down the PWM logic to turn off the high-side MOSFET. The high-side MOSFET stays off until the next clock signal comes for the next cycle.

The output voltage is sensed by a resistor divider from V_{OUT} to the FB pin. The difference between the FB voltage and 0.8V reference is amplified and compensated to generate the error voltage signal at the COMP pin. Then the COMP pin signal is compared with the current ramp signal to shut down the PWM.

PFM Mode Operation

To pull the MODE pin HIGH (>2.5V) or leave the MODE pin floating will set the IC to have PFM (Pulse Frequency Modulation) operation in light load. In PFM mode, the switching frequency is dramatically reduced to minimize the switching loss. The ISL78200 enters PFM mode when the MOSFET peak current is lower than the PWM/PFM boundary current threshold. This threshold is 700mA as default when there is no programming resistor at MODE pin. It can also be programmed by a resistor at the MODE pin to ground (see Equation 2).

$$R_{MODE} = \frac{118500}{IPFM + 0.2} \quad (\text{EQ. 2})$$

where IPFM is the desired PWM/PFM boundary current threshold and R_{MODE} is the programming resistor.

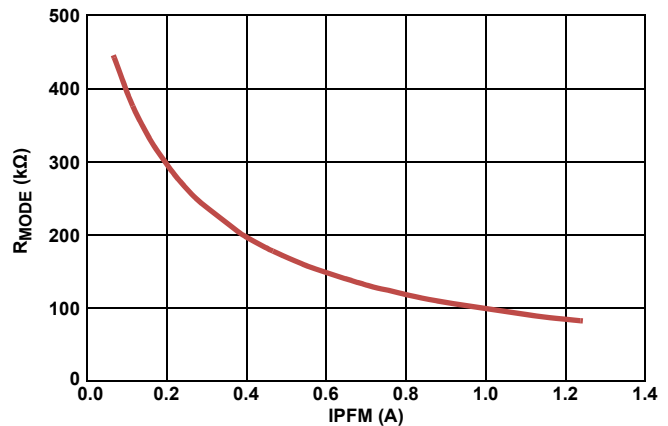

FIGURE 28. R_{MODE} vs IPFM

Synchronous and Non-Synchronous Buck

The ISL78200 supports both synchronous and non-synchronous buck operations. For a non-synchronous buck operation when a power diode is used as the low-side power device, the LGATE driver can be disabled with LGATE connected to VCC (before IC start-up).

AUXVCC Switch-Over

The ISL78200 has an auxiliary LDO integrated as shown in the block diagram. It is used to replace the internal MAIN LDO function after the IC start-up. “Typical Application Schematic II - V_{CC} Switch Over to V_{OUT} ” on page 5 shows its basic application setup with output voltage connected to AUXVCC. After IC soft-start done and the output voltage is built up to steady state, once the AUXVCC pin voltage is over the AUX LDO Switch-over Rising Threshold, the MAIN LDO is shut off and the AUXILIARY LDO is activated to bias VCC. Since the AUXVCC pin voltage is lower than input voltage V_{IN} , the internal LDO dropout voltage and the consequent power loss is reduced. This feature brings substantial efficiency improvements in light load range especially at high input voltage applications.

When the voltage at AUXVCC falls below the AUX LDO Switch-over Falling Threshold, the AUXILIARY LDO is shut off and the MAIN LDO

is re-activated to bias VCC. At the OV/UV fault events, the IC also switch over back from AUXILIARY LDO to MAIN LDO.

The AUXVCC switchover function is offered in buck configuration. It is not offered in boost configuration when the AUXVCC pin is used to monitor the boost output voltage for OVP.

Input Voltage

With the part switching, the operating ISL78200 input voltage must be under 40V. This recommendation allows for short voltage ringing spikes (within a couple of ns time range) due to part switching while not exceeding 44V as Absolute Maximum Ratings.

The lowest IC operating input voltage (VIN pin) depends on VCC voltage and the Rising and Falling VCC POR Threshold in Electrical Specifications table. At IC start-up when VCC is just over rising POR threshold, there is no switching yet before the soft-start starts. So the IC minimum start-up voltage on VIN pin is 3.05V (MAX of Rising VCC POR). When the soft-start is initiated, the regulator is switching and the dropout voltage across the internal LDO increases due to driving current. Thus the IC VIN pin shutdown voltage is related to driving current and VCC POR falling threshold. The internal upper side MOSFET has typical 10nC gate drive. For a typical example of synchronous buck with 4nC lower MOSFET gate drive and 500kHz switching frequency, the driving current is 7mA total causing 70mV drop across internal LDO under 3V Vin. Then the IC shut down voltage on VIN pin is 2.87V (2.8V+0.07V). In practical design, extra room should be taken into account with concerns of voltage spikes at VIN.

With boost buck configuration, the input voltage range can be expanded further down to 2.5V or lower depending on the boost stage voltage drop upon maximum duty cycle. Since the boost output voltage is connected to VIN pin as the buck inputs, after the IC starts up, the IC will keep operating and switching as long as the boost output voltage can keep the VCC voltage higher than falling threshold. Refer to "Boost Converter Operation" on page 14 for more details.

Output Voltage

The ISL78200 output voltage can be programmed down to 0.8V by a resistor divider from V_{OUT} to FB. The maximum achievable voltage is $(V_{IN} * D_{MAX} - V_{DROP})$, where V_{DROP} is the voltage drop in the power path including mainly the MOSFET r_{DS(ON)} and inductor DCR. The maximum duty cycle D_{MAX} is decided by $(1 - F_s * t_{MIN(OFF)})$.

Output Current

With the high-side MOSFET integrated, the maximum current ISL78200 can support is decided by the package and many operating conditions including input voltage, output voltage, duty cycle, switching frequency and temperature, etc.

First: The maximum output current is limited by the maximum OC threshold that is 4.18A (TYP).

Second: From the thermal perspective, the die temperature shouldn't be above +125°C with the power loss dissipated inside of the IC. Figures 12 through 14 show the thermal performance of this part operating at different conditions. The part can output

2.5A under typical application condition V_{IN} 8~36V, V_O 5V, 500kHz, still air and +85°C ambient conditions. The output current should be derated under any conditions causing the die temperature to exceed +125°C.

Figure 12 shows a 5V, 2A output application over V_{IN} range under +105°C ambient temperature with 100 CFM air flow.

Figure 13 shows 2A applications under +25°C still air conditions. Different V_{OUT} (5V, 9V, 12V, 20V) applications thermal data are shown over V_{IN} range at +25°C and still air. The temperature rise data in this figure can be used to estimate the die temperature at different ambient temperatures under various operating conditions. Note: More temperature rise is expected at higher ambient temperatures due to more conduction loss caused by r_{DS(ON)} increase.

Figure 14 shows thermal performance under various output currents and input voltages. It shows the temperature rise trend with load and V_{IN} changes.

Basically, the die temperature equals the sum of ambient temperature and the temperature rise resulting from power dissipated from the IC package with a certain junction to ambient thermal impedance θ_{JA} . The power dissipated in the IC is related to the MOSFET switching loss, conduction loss and the internal LDO loss. Besides the load, these losses are also related to input voltage, output voltage, duty cycle, switching frequency and temperature. With the exposed pad at the bottom, the heat of the IC mainly goes through the bottom pad and θ_{JA} is greatly reduced. The θ_{JA} is highly related to layout and air flow conditions. In layout, multiple vias (20) are strongly recommended in the IC bottom pad. In addition, the bottom pad with its vias should be placed in ground copper plane with an area as large as possible connected through multiple layers. The θ_{JA} can be reduced further with air flow. Refer to Figure 12 for the thermal performance with 100 CFM air flow.

Boost Converter Operation

The Typical Application Schematic III on page 5 shows the circuits where the boost works as a pre-stage to provide input to the following Buck stage. This is for applications when the input voltage could drop to a very low voltage in some constants (in some battery powered systems as an example), causing the output voltage drops out of regulation. The boost converter can be enabled to boost the input voltage up to keep the output voltage in regulation. When the system input voltage recovers back to normal, the boost stage is disabled while only the buck stage is switching.

EXT_BOOST pin is used to set boost mode and monitor the boost input voltage. At IC start-up before soft-start, the controller will latch in boost mode when the voltage on this pin is above 200mV; it will latch in synchronous buck mode if voltage on this pin is below 200mV. In boost mode, the low-side driver output PWM has the same PWM signal with the buck regulator.

In boost mode, the EXT_BOOST pin is used to monitor boost input voltage to turn on and turn off the boost PWM. The AUXVCC pin is used to monitor the boost output voltage to turn on and turn off the boost PWM.

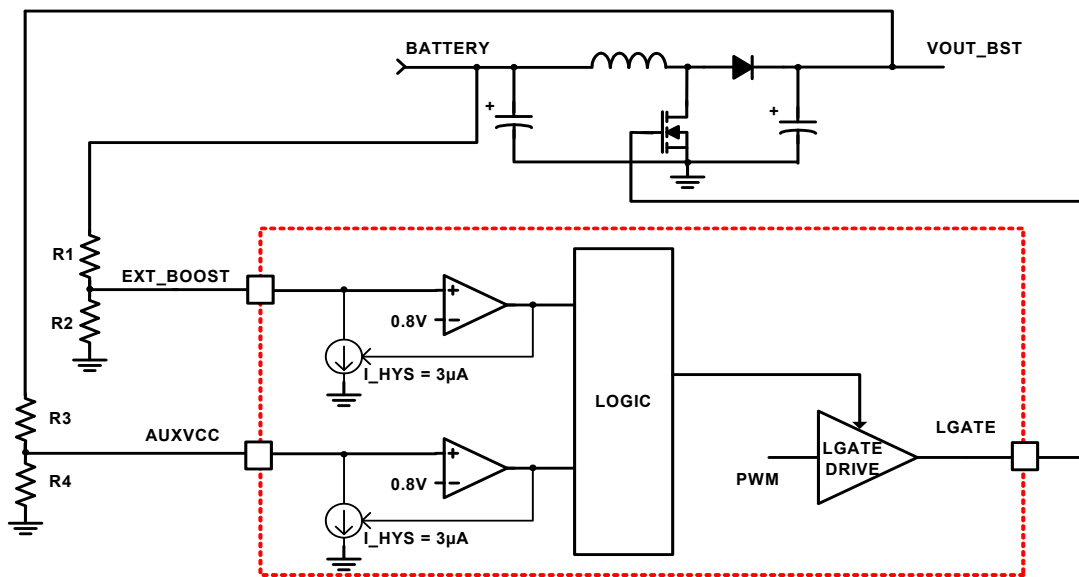

FIGURE 29. BOOST CONVERTER CONTROL

Referring to Figure 29, a resistor divider from boost input voltage to the EXT_BOOST pin is used to detect the boost input voltage. When the voltage on the EXT_BOOST pin is below 0.8V, the boost PWM is enabled with a fixed 500µs soft-start when the boost duty cycle increases from $t_{MINON} \cdot F_s$ to ~50% and a 3µA sinking current is enabled at the EXT_BOOST pin for hysteresis purposes. When the voltage on the EXT_BOOST pin recovers to above 0.8V, the boost PWM is disabled immediately. Use Equation 3 to calculate the upper resistor R_{UP} (R1 in Figure 29) for a desired hysteresis V_{HYS} at boost input voltage

$$R_{UP}[\text{M}\Omega] = \frac{V_{HYS}}{3[\mu\text{A}]} \quad (\text{EQ. 3})$$

Use Equation 4 to calculate the lower resistor R_{LOW} (R2 in Figure 29) according to a desired boost enable threshold.

$$R_{LOW} = \frac{R_{UP} \cdot 0.8}{V_{FTH} - 0.8} \quad (\text{EQ. 4})$$

where V_{FTH} is the desired falling threshold on boost input voltage to turn on the boost, 3µA is the hysteresis current, and 0.8V is the reference voltage to be compared.

Note the boost start-up threshold has to be selected in a way that the buck is operating well at close loop before boost start-up. Otherwise, large inrush current at boost start-up could occur at boost input due to the buck loop saturation.

Similarly, a resistor divider from boost output voltage to the AUXVCC pin is used to detect the boost output voltage. When the voltage on AUXVCC pin is below 0.8V, the boost PWM is enabled with a fixed 500µs soft-start, and a 3µA sinking current is enabled at AUXVCC pin for hysteresis purpose. When the voltage on the AUXVCC pin recovers to above 0.8V, the boost PWM is disabled immediately. Use Equation 3 to calculate the upper resistor R_{UP} (R3 in Figure 29) according to a desired hysteresis V_{HY} at boost output voltage. Use Equation 4 to calculate the lower resistor R_{LOW} (R4 in Figure 29) according to a desired boost enable threshold at boost output.

Assuming V_{BAT} is the boost input voltage, V_{OUTBST} is the boost output voltage and V_{OUT} is the buck output voltage, the steady state transfer functions are:

$$V_{OUTBST} = \frac{1}{1-D} \cdot V_{BAT} \quad (\text{EQ. 5})$$

$$V_{OUT} = D \cdot V_{OUTBST} = \frac{D}{1-D} \cdot V_{BAT} \quad (\text{EQ. 6})$$

From Equation 5 and Equation 6, Equation 7 can be derived to estimate the steady state boost output voltage as a function of V_{BAT} and V_{OUT} :

$$V_{OUTBST} = V_{BAT} + V_{OUT} \quad (\text{EQ. 7})$$

After the IC starts up, the boost buck converters can keep working when the battery voltage drops extremely low because the IC's bias (VCC) LDO is powered by the boost output. For an example of 3.3V output application, when the battery drops to 2V, the V_{IN} pin voltage is powered by the boost output voltage that is 5.2V (Equation 7), meaning the V_{IN} pin (buck input) still needs 5.2V to keep the IC working.

Note in the above mentioned case, the boost input current could be high because the input voltage is very low ($V_{IN} \cdot I_{IN} = V_{OUT} \cdot I_{OUT} / \text{Efficiency}$). If the design is to achieve the low input operation with full load, the inductor and MOSFET have to be selected to have enough current ratings to handle the high current appearing at boost input. The boost inductor current are the same with the boost input current, which can be estimated in Equation 8, where P_{OUT} is the output power, V_{BAT} is the boost input voltage, and EFF is the estimated efficiency of the whole boost and buck stages.

$$I_{L_{IN}} = \frac{P_{OUT}}{V_{BAT} \cdot EFF} \quad (\text{EQ. 8})$$

Based on the same concerns of boost input current, the start-up sequence must follow the rule that the IC is enabled after the boost input voltage rise above a certain level. The shutdown sequence must follow the rule that the IC is disabled first before

the boost input power source is turned off. At boost mode applications where there is no external control signal to enable/disable the IC, an external input UVLO circuit must be implemented for the start-up and shutdown sequence.

PFM is not available in boost mode.

Oscillator and Synchronization

The oscillator has a default frequency of 500kHz with the FS pin connected to VCC, ground, or floating. The frequency can be programmed to any frequency between 200kHz and 2.2MHz with a resistor from the FS pin to GND.

$$R_{FS}[k\Omega] = \frac{145000 - 16 \cdot FS[kHz]}{FS[kHz]} \quad (\text{EQ. 9})$$

The SYNC pin is bi-directional and it outputs the IC's default or programmed local clock signal when it's free running. The IC locks to an external clock injected to SYNC pin (external clock frequency recommended to be 10% higher than the free running frequency). The delay from the rising edge of the external clock signal to the PHASE rising edge is half of the free running switching period pulse 220ns, (0.5Tsw+220ns). The maximum external clock frequency is recommended to be 1.6 of the free running frequency.

When the part enters PFM pulse skipping mode, the synchronization function is shut off and also no clock signal output in SYNC pin.

With the SYNC pins simply connected together, multiple ISL78200s can be synchronized. The slave ICs automatically have 180° phase shift respect to the master IC.

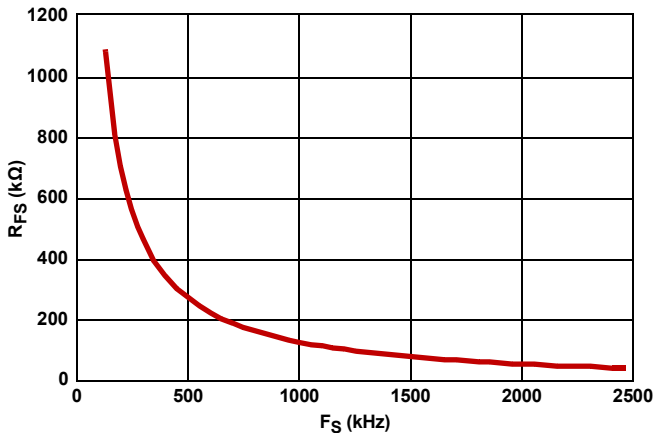

FIGURE 30. R_{FS} vs FREQUENCY

Fault Protection

Overcurrent Protection

The overcurrent function protects against any overload condition and output shorts at worst case, by monitoring the current flowing through the upper MOSFET.

There are 2 current limiting thresholds. The first one, I_{OC1}, is to limit the high-side MOSFET peak current cycle-by-cycle. The current limit threshold is set to default at 3.6A with the ILIMIT pin connected to GND or VCC, or left open. The current limit threshold

can also be programmed by a resistor, R_{LIM}, at the ILIMIT pin to ground. Use Equation 10 to calculate the resistor.

$$R_{LIM} = \frac{300000}{I_{OC}[A] + 0.018} \quad (\text{EQ. 10})$$

Note that with the lower R_{LIM}, I_{OC1} is higher. Considering the OC programming circuit tolerances over temperature range -40°C to +105°C, 71.5k is the lowest resistor value recommended to be used for R_{LIM} to achieve highest OC threshold. With 71.5k R_{LIM}, the OC limit is 4.18A (TYP). Resistor lower than 71.5k would result in default 3.6A OC1 threshold.

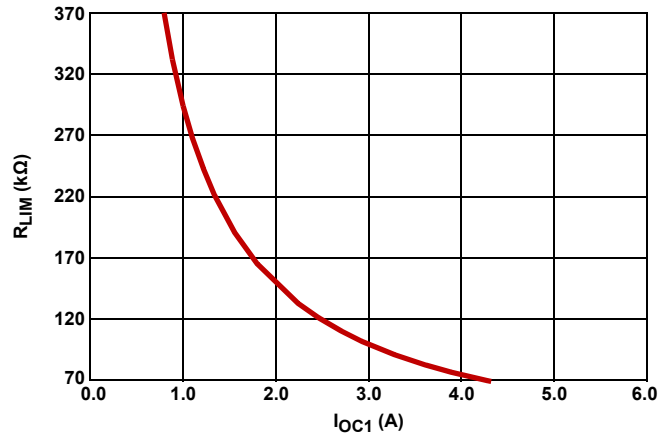

FIGURE 31. R_{LIM} vs I_{OC1}

The second current protection threshold, I_{OC2}, is 15% higher than I_{OC1} mentioned above. At the instant the high-side MOSFET current reaches I_{OC2}, the PWM shuts off after a 2 cycle delay and the IC enters hiccup mode. In hiccup mode, the PWM is disabled for a dummy soft-start duration equal to 5 regular soft-start periods. After this dummy soft-start cycle, the true soft-start cycle is attempted again. The I_{OC2} offers a robust and reliable protection against worst case conditions.

The frequency fold back is implemented for the ISL78200. When overcurrent limiting, the switching frequency is reduced to proportional to the output voltage in order to keep the inductor current under the limit threshold during overload condition. The low limit of frequency under frequency foldback is 40kHz.

Overvoltage Protection

If the voltage detected on the FB pin is over 110% of reference, the high-side and low-side drivers shut down immediately and won't be allowed on until the FB voltage falls down to 0.8V. When the FB voltage drops to 0.8V, the drivers are released on. If the 120% overvoltage threshold is reached, the high-side and low-side driver shut down immediately and the IC is latched off. The IC has to be reset for restart.

Thermal Protection

The ISL78200 PWM will be disabled if the junction temperature reaches +155°C. A +15°C hysteresis insures that the device will not restart until the junction temperature drops below +140°C.

Component Selections

ISL78200 iSim model available in internet can be used to simulate the operating behaviors to assist the design.

Output Capacitors

An output capacitor is required to filter the inductor current. Output ripple voltage and transient response are 2 critical factors when considering output capacitance choice. The current mode control loop allows the usage of low ESR ceramic capacitors and thus smaller board layout. Electrolytic and polymer capacitors may also be used.

Additional consideration applies to ceramic capacitors. While they offer excellent overall performance and reliability, the actual in-circuit capacitance must be considered. Ceramic capacitors are rated using large peak-to-peak voltage swings and with no DC bias. In the DC/DC converter application, these conditions do not reflect reality. As a result, the actual capacitance may be considerably lower than the advertised value. Consult the manufacturers data sheet to determine the actual in-application capacitance. Most manufacturers publish capacitance vs DC bias so that this effect can be easily accommodated. The effects of AC voltage are not frequently published, but an assumption of ~20% further reduction will generally suffice. The result of these considerations can easily result in an effective capacitance 50% lower than the rated value. Nonetheless, they are a very good choice in many applications due to their reliability and extremely low ESR.

The following equations allow calculation of the required capacitance to meet a desired ripple voltage level. Additional capacitance may be used.

For the ceramic capacitors (low ESR):

$$V_{OUT\text{ripple}} = \frac{\Delta I}{8 * F_{SW} * C_{OUT}} \quad (\text{EQ. 11})$$

where ΔI is the inductor's peak to peak ripple current, F_{SW} is the switching frequency and C_{OUT} is the output capacitor.

If using electrolytic capacitors then:

$$V_{OUT\text{ripple}} = \Delta I * \text{ESR} \quad (\text{EQ. 12})$$

Regarding transient response needs, a good starting point is to determine the allowable overshoot in V_{OUT} if the load is suddenly removed. In this case, energy stored in the inductor will be transferred to C_{OUT} causing its voltage to rise. After calculating capacitance required for both ripple and transient needs, choose the larger of the calculated values. The following equation determines the required output capacitor value in order to achieve a desired overshoot relative to the regulated voltage.

$$C_{OUT} = \frac{I_{OUT}^2 * L}{V_{OUT}^2 * (V_{OUT\text{MAX}}/V_{OUT})^2 - 1} \quad (\text{EQ. 13})$$

where $V_{OUT\text{MAX}}/V_{OUT}$ is the relative maximum overshoot allowed during the removal of the load.

Input Capacitors

Depending upon the system input power rail conditions, the aluminum electrolytic type capacitor is normally needed to provide the stable input voltage and restrict the switching frequency pulse current in small areas over the input traces for better EMC performance. The input capacitor should be able to handle the RMS current from the switching power devices.

Ceramic capacitors must be used at the VIN pin of the IC and multiple capacitors including 1 μ F and 0.1 μ F are recommended. Place these capacitors as closely as possible to the IC.

Output Inductor

The inductor value determines the converter's ripple current. Choosing an inductor current requires a somewhat arbitrary choice of ripple current, ΔI . A reasonable starting point is 30% to 40% of total load current. The inductor value can then be calculated using Equation:

$$L = \frac{V_{IN} - V_{OUT}}{F_s * \Delta I} * \frac{V_{OUT}}{V_{IN}} \quad (\text{EQ. 14})$$

Increasing the value of inductance reduces the ripple current and thus ripple voltage. However, the larger inductance value may reduce the converter's response time to a load transient. The inductor current rating should be such that it will not saturate in overcurrent conditions.

Low-Side Power MOSFET

In synchronous buck application, a power N MOSFET is needed as the synchronous low-side MOSFET and a good one should have low Q_{gd} , low $r_{DS(ON)}$ and small R_g ($R_{g_typ} < 1.5\Omega$ recommended). V_{gth_min} is recommended to be higher than 1.2V. A good example is SQS462EN.

Output Voltage Feedback Resistor Divider

The output voltage can be programmed down to 0.8V by a resistor divider from V_{OUT} to FB according to Equation 15.

$$V_{OUT} = 0.8 * \left(1 + \frac{R_{UP}}{R_{LOW}} \right) \quad (\text{EQ. 15})$$

In applications requiring the least input quiescent current, large resistors should be used for the divider to keep its leakage current low. 232k is a recommended for the upper resistor.

Loop Compensation Design

The ISL78200 uses constant frequency peak current mode control architecture to achieve fast loop transient response. An accurate current sensing pilot device in parallel with the upper MOSFET is used for peak current control signal and overcurrent protection. The inductor is not considered as a state variable since its peak current is constant, and the system becomes single order system. It is much easier to design the compensator to stabilize the loop compared with voltage mode control. Peak current mode control has inherent input voltage feed-forward function to achieve good line regulation. Figure 32 shows the small signal model of a buck regulator.

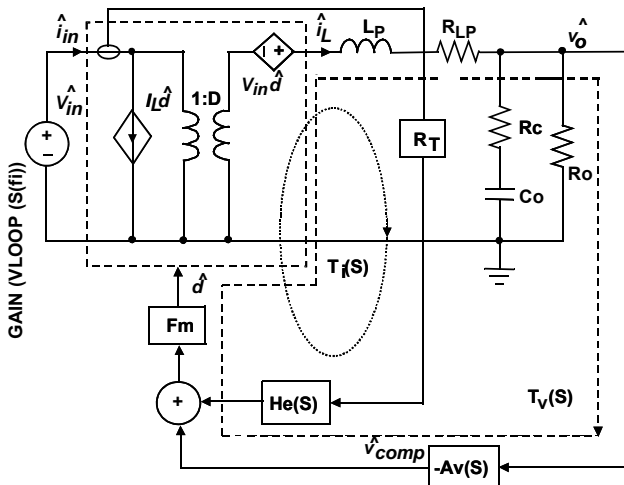

FIGURE 32. SMALL SIGNAL MODEL OF BUCK REGULATOR

PWM Comparator Gain F_m:

The PWM comparator gain F_m for peak current mode control is given by Equation 16:

$$F_m = \frac{\hat{d}}{v_{comp}} = \frac{1}{(S_e + S_n)T_s} \quad (EQ. 16)$$

Where, S_e is the slew rate of the slope compensation and S_n is given by Equation 17

$$S_n = R_t \frac{V_{in} - V_o}{L_p} \quad (EQ. 17)$$

where, R_t is the gain of the current amplifier.

CURRENT SAMPLING TRANSFER FUNCTION H_e(S):

In current loop, the current signal is sampled every switching cycle. It has the following transfer function in Equation 18:

$$H_e(S) = \frac{S^2}{\omega_n^2} + \frac{S}{\omega_n Q_n} + 1 \quad (EQ. 18)$$

where, Q_n and ω_n are given by $Q_n = \frac{2}{\pi}, \omega_n = \pi f_s$

Power Stage Transfer Functions

Transfer function F₁(S) from control to output voltage is:

$$F_1(S) = \frac{\hat{v}_o}{\hat{d}} = V_{in} \frac{1 + \frac{S}{\omega_{esr}}}{\frac{S^2}{\omega_o^2} + \frac{S}{\omega_o Q_p} + 1} \quad (EQ. 19)$$

Where,

$$\omega_{esr} = \frac{1}{R_c C_o}, Q_p \approx R_o \sqrt{\frac{C_o}{L_p}}, \omega_o = \frac{1}{\sqrt{L_p C_o}}$$

Transfer function F₂(S) from control to inductor current is given by Equation 20:

$$\text{where } \omega_z = \frac{1}{R_o C_o}$$

$$F_2(S) = \frac{\hat{i}_o}{\hat{d}} = \frac{V_{in}}{R_o + R_{LP}} \frac{1 + \frac{S}{\omega_z}}{\frac{S^2}{\omega_o^2} + \frac{S}{\omega_o Q_p} + 1} \quad (EQ. 20)$$

Current loop gain T_i(S) is expressed as Equation 21:

$$T_i(S) = R_t F_m F_2(S) H_e(S) \quad (EQ. 21)$$

The voltage loop gain with open current loop is Equation 22:

$$T_v(S) = K F_m F_1(S) A_v(S) \quad (EQ. 22)$$

The Voltage loop gain with current loop closed is given by Equation 23:

$$L_v(S) = \frac{T_v(S)}{1 + T_i(S)} \quad (EQ. 23)$$

If T_i(S) >> 1, then Equation 23 can be simplified as Equation 24:

$$L_v(S) = \frac{R_o + R_{LP}}{R_t} \frac{1 + \frac{S}{\omega_{esr}} A_v(S)}{1 + \frac{S}{\omega_p} H_e(S)}, \omega_p \approx \frac{1}{R_o C_o} \quad (EQ. 24)$$

Equation 24 shows that the system is a single order system. Therefore, a simple type II compensator can be easily used to stabilize the system. While type III compensator is needed to expand the bandwidth for current mode control in some cases.

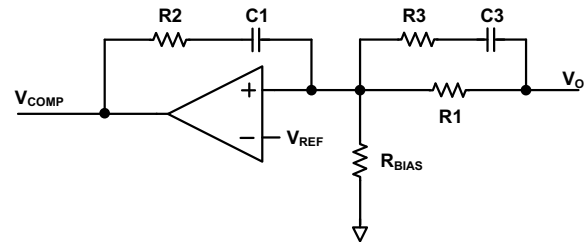

FIGURE 33. TYPE III COMPENSATOR

A compensator with 2 zeros and 1 pole is recommended for this part as shown in Figure 33. Its transfer function is expressed as Equation 25:

$$A_v(S) = \frac{\hat{v}_{comp}}{v_o} = \frac{1}{SR_1 C_1} \frac{\left(1 + \frac{S}{\omega_{cz1}}\right) \left(1 + \frac{S}{\omega_{cz2}}\right)}{\left(1 + \frac{S}{\omega_{cp}}\right)} \quad (EQ. 25)$$

where,

$$\omega_{cz1} = \frac{1}{R_2 C_1}, \omega_{cz2} = \frac{1}{(R_1 + R_3) C_3}, \omega_{cp} = \frac{1}{R_3 C_3}$$

Compensator design goal:

Loop bandwidth f_c: $\left(\frac{1}{4} \text{ to } \frac{1}{10}\right) f_s$

Gain margin: >10dB

Phase margin: 45°

The compensator design procedure is as follows:

1. Position ω_{CZ2} and ω_{CP} to derive R3 and C3.

Put the compensator zero ω_{CZ2} at $(1 \text{ to } 3)/(R_0 C_0)$

$$\omega_{CZ2} = \frac{3}{R_0 C_0} \quad (\text{EQ. 26})$$

Put the compensator pole ω_{CP} at ESR zero or 0.35 to 0.5 times of switching frequency, whichever is lower. In all-ceramic-cap design, the ESR zero is normally higher than half of the switching frequency. R3 and C3 can be derived as following:

Case A: ESR zero $\frac{1}{2\pi R_c C_0}$ less than $(0.35 \text{ to } 0.5)f_s$

$$C_3 = \frac{R_0 C_0 - 3R_c C_0}{3R_1} \quad (\text{EQ. 27})$$

$$R_3 = \frac{3R_c R_1}{R_0 - 3R_c} \quad (\text{EQ. 28})$$

Case B: ESR zero $\frac{1}{2\pi R_c C_0}$ larger than $(0.35 \text{ to } 0.5)f_s$

$$C_3 = \frac{0.33R_0 C_0 f_s - 0.46}{f_s R_1} \quad (\text{EQ. 29})$$

$$R_3 = \frac{R_1}{0.73R_0 C_0 f_s - 1} \quad (\text{EQ. 30})$$

Case C: Derive at R2 and C1.

The loop gain $L_v(S)$ at cross over frequency of f_c has unity gain. Therefore, C1 is determined by Equation 31.

$$C_1 = \frac{(R_1 + R_3)C_3}{2\pi f_c R_t R_1 C_0} \quad (\text{EQ. 31})$$

The compensator zero ω_{CZ1} can boost the phase margin and bandwidth. To put ω_{CZ1} at 2 times of cross cover frequency f_c is a good start point. It can be adjusted according to specific design. R1 can be derived from Equation 32.

$$R_2 = \frac{1}{4\pi f_c C_1} \quad (\text{EQ. 32})$$

Example: $V_{IN} = 12V$, $V_o = 5V$, $I_o = 2A$, $f_s = 500kHz$, $C_0 = 60\mu F/3m\Omega$, $L = 10\mu H$, $R_t = 0.20V/A$, $f_c = 50kHz$, $R_1 = 105k$, $R_{BIAS} = 20k\Omega$.

Select the crossover frequency to be 35kHz. Since the output capacitors are all ceramics, use Equation 29 and 30 to derive R3 to be 20k and C3 to be 470pF.

Then use Equation 31 and 32 to calculate C1 to be 180pF and R2 to be 12.7k. Select 150pF for C1 and 15k for R2.

There is approximately 30pF parasitic capacitance between COMP to FB pins that contributes to a high frequency pole.

Figure 34 shows the simulated bode plot of the loop. It is shown that it has 26kHz loop bandwidth with 70° phase margin and -28dB gain margin.

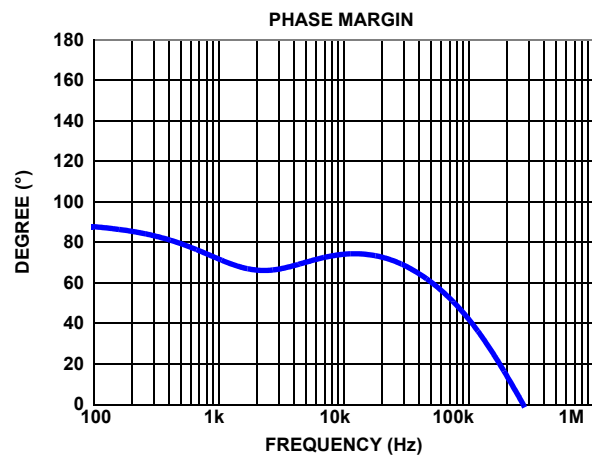
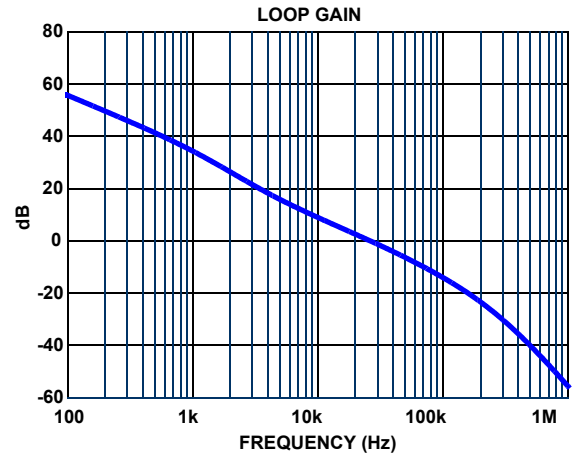

FIGURE 34. SIMULATED LOOP BODE PLOT

Note in applications where the PFM mode is desired especially when type III compensation network is used, the value of the capacitor between the COMP pin and the FB pin (not the capacitor in series with the resistor between COMP and FB) should be minimal to reduce the noise coupling for proper PFM operation. No external capacitor between COMP and FB is recommended at PFM applications.

Boost Inductor

Besides the need to sustain the current ripple to be within a certain range (30% to 50%), the boost inductor current at its soft-start is a more important perspective to be considered in selection of the boost inductor. Each time the boost starts up, there is a fixed 500μs soft-start time when the duty cycle increase linearly from t_{MINON} to ~50%. Before and after boost start-up, the boost output voltage will jump from V_{IN_boost} to voltage ($V_{IN_boost} + V_{OUT_buck}$). The design target in boost soft-start is to ensure the boost input current is sustained to a minimum but capable of charging the boost output voltage to have a voltage step equaling to V_{OUT_buck} . A big inductor will block the inductor current increase and not high enough to be able to charge the output capacitor to the final steady state value ($V_{IN_boost} + V_{OUT_buck}$) within 500μs. A 6.8μH inductor is a good starting point for its selection in design. The boost inductor current at start-up must be checked by an oscilloscope to ensure

it is under the acceptable range. Suggest to run the iSim model simulation to select the proper inductor value.

Boost Output Capacitor

Based on the same theory in boost start-up described above in boost inductor selection, a large capacitor at boost output will cause high inrush current at boost PWM start-up. 22 μ F is a good choice for applications with buck output voltage less than 10V. Also, some minimum amount of capacitance has to be used in boost output to keep the system stable. Suggest to run the iSim model simulation to select the proper inductor value.

Layout Suggestions

1. Put the input ceramic capacitors as close to the IC VIN pin and power ground connecting to the power MOSFET or diode. Keep this loop (input ceramic capacitor, IC V_{IN} pin and MOSFET/diode) as tiny as possible to achieve the least voltage spikes induced by the trace parasitic inductance.
2. Put the input aluminum capacitors close to IC VIN pin.
3. Keep the phase node copper area small but large enough to handle the load current.
4. Put the output ceramic and aluminum capacitors also close to the power stage components.
5. Put vias (20 recommended) in the bottom pad of the IC. The bottom pad should be placed in the ground copper plane with an area as large as possible in multiple layers to effectively reduce the thermal impedance.
6. Place the 4.7 μ F ceramic decoupling capacitor at the VCC pin and as close as possible to the IC. Put multiple vias (≥ 3) close to the ground pad of this capacitor.
7. Keep the bootstrap capacitor close to the IC.
8. Keep the LGATE drive trace as short as possible and try to avoid using a via in the LGATE drive path to achieve the lowest impedance.
9. Place the positive voltage sense trace close to the load for tighter regulation.
10. Place all the peripheral control components close to the IC.

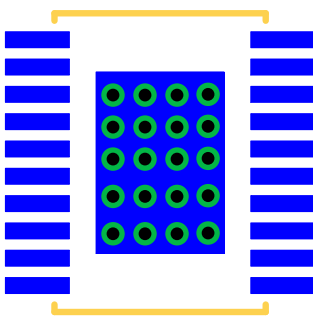

FIGURE 35. PCB VIA PATTERN

Revision History

The revision history provided is for informational purposes only and is believed to be accurate, but not warranted. Please go to web to make sure you have the latest Rev.

DATE	REVISION	CHANGE
December 24, 2013	FN7641.2	Page 21 - 2nd line of the disclaimer changed from: "Intersil products are manufactured, assembled and tested utilizing ISO9001 quality systems as noted" to: "Intersil Automotive Qualified products are manufactured, assembled and tested utilizing TS16949 quality systems as noted"
May 17, 2012	FN7641.1	On page 6 - Electrical Spec Table VIN SUPPLY, changed "Standby Supply Current" to "ShutDown Supply Current" and changed Symbol "IQ_SBY" to IIN_SD On page 7 - Electrical Spec Table SYNCHRONIZATION, changed Symbol "VOH" to "VIL" On page 12 - Added Efficiency Boost Buck performance Curve Updated Equation 31 on page 19 by adding C3 to the equation, which was missing. Deleted following sentence from last paragraph of "Power Stage Transfer Functions" on page 19: "A capacitor (<1nF) at the FB pin to ground also helps proper PFM mode operation".
April 26, 2012		Added typical electrical specification of EN pull-up current and Synchronization on page 7. Added boost-buck efficiency curve and "AUXVCC Switch-Over" on page 13. Under "Output Voltage" on page 14 description, changed "(1/Fs * tMIN(OFF))" To "(1 - Fs * tMIN(OFF))". Under "Boost Converter Operation" on page 14, changed "(VIN*IIN = VOUT*IOUT*Efficiency)" to "(VIN*IIN = VOUT*IOUT/Efficiency)". Added recommendation of the maximum programmable OC threshold to be 4.18A(TYP) with 71.5k R _{LIM} on page 16. Added to "Component Selections" on page 17 application design guides for selection of inductor and capacitor and loop compensation.
September 22, 2011	FN7641.0	Initial Release

About Intersil

Intersil Corporation is a leader in the design and manufacture of high-performance analog, mixed-signal and power management semiconductors. The company's products address some of the largest markets within the industrial and infrastructure, personal computing and high-end consumer markets. For more information about Intersil, visit our website at www.intersil.com.

For the most updated datasheet, application notes, related documentation and related parts, please see the respective product information page found at www.intersil.com. You may report errors or suggestions for improving this datasheet by visiting www.intersil.com/en/support/ask-an-expert.html. Reliability reports are also available from our website at <http://www.intersil.com/en/support/qualandreliability.html#reliability>

© Copyright Intersil Americas LLC 2012-2013. All Rights Reserved.

All trademarks and registered trademarks are the property of their respective owners.

For additional products, see www.intersil.com/en/products.html

Intersil Automotive Qualified products are manufactured, assembled and tested utilizing TS16949 quality systems as noted in the quality certifications found at www.intersil.com/en/support/qualandreliability.html

Intersil products are sold by description only. Intersil may modify the circuit design and/or specifications of products at any time without notice, provided that such modification does not, in Intersil's sole judgment, affect the form, fit or function of the product. Accordingly, the reader is cautioned to verify that datasheets are current before placing orders. Information furnished by Intersil is believed to be accurate and reliable. However, no responsibility is assumed by Intersil or its subsidiaries for its use; nor for any infringements of patents or other rights of third parties which may result from its use. No license is granted by implication or otherwise under any patent or patent rights of Intersil or its subsidiaries.

For information regarding Intersil Corporation and its products, see www.intersil.com

HTSSOP (Heat-Sink TSSOP) Family

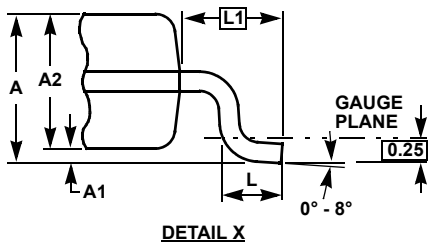
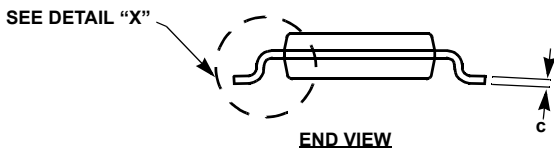
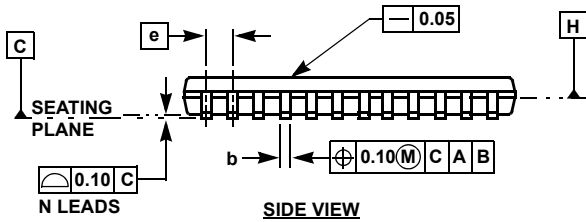
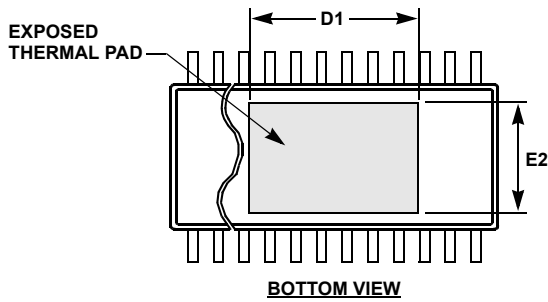
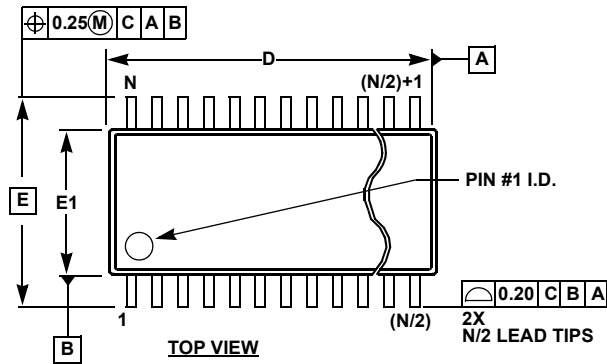

MDP0048

HTSSOP (HEAT-SINK TSSOP) FAMILY

SYMBOL	MILLIMETERS					TOLERANCE
	14 LD	20 LD	24 LD	28 LD	38 LD	
A	1.20	1.20	1.20	1.20	1.20	Max
A1	0.075	0.075	0.075	0.075	0.075	±0.075
A2	0.90	0.90	0.90	0.90	0.90	+0.15/-0.10
b	0.25	0.25	0.25	0.25	0.22	+0.05/-0.06
c	0.15	0.15	0.15	0.15	0.15	+0.05/-0.06
D	5.00	6.50	7.80	9.70	9.70	±0.10
D1	3.2	4.2	4.3	5.0	7.25	Reference
E	6.40	6.40	6.40	6.40	6.40	Basic
E1	4.40	4.40	4.40	4.40	4.40	±0.10
E2	3.0	3.0	3.0	3.0	3.0	Reference
e	0.65	0.65	0.65	0.65	0.50	Basic
L	0.60	0.60	0.60	0.60	0.60	±0.15
L1	1.00	1.00	1.00	1.00	1.00	Reference
N	14	20	24	28	38	Reference

Rev. 3 2/07

NOTES:

1. Dimension "D" does not include mold flash, protrusions or gate burrs. Mold flash, protrusions or gate burrs shall not exceed 0.15mm per side.
2. Dimension "E1" does not include interlead flash or protrusions. Interlead flash and protrusions shall not exceed 0.25mm per side.
3. Dimensions "D" and "E1" are measured at Datum Plane H.
4. Dimensioning and tolerancing per ASME Y14.5M-1994.