

## ISL94216

### 16-Cell Battery Front End

The [ISL94216](#) is a 16-cell Battery Front End (BFE) IC, an essential component of any Battery Management System (BMS), which periodically scans battery status and the operating environment to optimize battery life and prevent catastrophic failures.

A differential multiplexer and 16-bit ADC allows for accurate monitoring of cell voltage, temperature, and load current for management of the overall state of the battery pack.

The ISL94216 supports I<sup>2</sup>C, SPI, and Single Wire protocols allowing customers to connect an MCU in a proprietary battery management solution.

Low current consumption with an average IDLE mode current of 200μA and a SHIP mode current of less than 18μA maximizes the storage and discharge life of a battery pack.

The ISL94216 features internal cell balancing circuitry that provides 8mA of balance current per cell. External cell balancing for higher currents is also supported.

This 16-cell high voltage BFE IC is offered in an efficient 64 Ld QFN package with a thermal pad.

### Features

- High hot plug rating: 62V
- V<sub>CELL</sub> accuracy: ±5mV
- I<sub>PACK</sub> accuracy: ±0.2%
- 16-bit V<sub>CELL</sub> and I<sub>PACK</sub> measurements
- Charge/Load wakeup detection circuitry
- 4-pin GPIO port
- Integrated 3.3V regulator
- Supports I<sup>2</sup>C, SPI, and Single Wire communications

### Applications

- Light electric vehicles such as e-bikes, e-scooters, and e-motorcycles
- Cordless power and gardening tools
- Home appliances
- 24V, 36V, 42V, and 48V portable battery packs
- Telecom and server farms
- Solar farms
- Energy storage systems

## Contents

<b>1. Overview</b>	<b>6</b>
1.1 Typical Application	6
1.2 Block Diagram	7
1.3 Ordering Information	8
<b>2. Pin Information</b>	<b>9</b>
2.1 Pin Assignments	9
2.2 Pin Descriptions	9
<b>3. Specifications</b>	<b>12</b>
3.1 Absolute Maximum Ratings	12
3.2 Thermal Information	13
3.3 Recommended Operation Conditions	13
3.4 Electrical Specifications	14
<b>4. Typical Performance Curves</b>	<b>23</b>
<b>5. System Registers</b>	<b>36</b>
5.1 IC Device Details	39
5.1.1 0x00 Product ID Register (R)	39
5.2 Global IC Controls	39
5.2.1 0x01 Global Operation	39
5.3 $V_{CELL}$ and $I_{PACK}$ Measurement	41
5.3.1 0x02 $V_{CELL}$ Operation	42
5.3.2 0x03 $I_{PACK}$ Operation	43
5.3.3 0x04 - 0x05 Cell Select	44
5.3.4 0x30 - 0x4F $V_{CELL}$ Voltage (R)	45
5.3.5 0x50 - 0x51 $V_{CELL}$ Max Delta Voltage (R)	45
5.3.6 0x52 - 0x53 $I_{PACK}$ Voltage (R)	46
5.3.7 0x54 - 0x57 $I_{PACK}$ Timer (R)	46
5.4 $V_{CELL}$ Fault Detectors	46
5.4.1 0x06 - 0x07 $V_{CELL}$ OV/UV Threshold	46
5.4.2 0x08 $V_{CELL}$ Max Delta Threshold	47
5.4.3 0x09 Fault Delay	48
5.5 $I_{PACK}$ Fault Detectors	49
5.5.1 0x0A DSC Threshold	49
5.5.2 0x0B DOC Threshold	50
5.5.3 0x0C DSC Delay	50
5.5.4 0x0D OC Delay	51
5.5.5 0x0E Load/Charge Operations	52
5.5.6 0x0F COC Threshold	55
5.6 ETAUX Port	56
5.6.1 0x11 ETAUX Operation	56
5.7 0x12 $\overline{ALRT}$ and GPIO	57
5.7.1 0x12.7 $\overline{ALRT}$ Assert	58
5.7.2 0x12.6 $\overline{ALRT}$ Pulse EN	58
5.7.3 0x12.5:4 GPIO CONFIG	58
5.7.4 0x12.3:0 GPIO STATUS	59
5.8 ETAUX Detectors	59

5.8.1	0x13-1A ETAUX Thresholds	59
5.8.2	0x58-59 xT0, 0x5A-5B xT1 (R)	61
5.9	Internal Temperature	61
5.9.1	0x22 - 0x23 IOTW and IOTF Thresholds	61
5.9.2	0x5E Internal Temperature (R)	62
5.10	Regulator Measurements and Detectors	62
5.10.1	0x1B VREG Operation	63
5.10.2	0x1C VVCC Min Threshold	64
5.10.3	0x1D,1E IREGOC1, 2 Threshold	65
5.10.4	0x5F VVTEMP Voltage (R)	65
5.10.5	0x60 VVCC Voltage (R)	65
5.10.6	0x61-62 IREG Voltage (R)	66
5.11	VBAT1	66
5.11.1	0x1F VBAT1 Operation	66
5.11.2	0x20 - 0x21 VBAT1 Thresholds	68
5.11.3	0x5C - 0x5D VBAT1 Voltage (R)	69
5.12	Power FET Block	70
5.12.1	0x24 Power FET Operation	70
5.13	Cell Balancing Registers	73
5.13.1	0x25 CB Operation	73
5.13.2	0x26-27 CB Cell State	75
5.13.3	0x2A CB Min Delta Threshold	76
5.13.4	0x2B CBMAX Threshold	76
5.13.5	0x2C CBMIN Threshold	77
5.13.6	0x2D VEOC Threshold	77
5.13.7	0x10 IEOC Threshold	78
5.13.8	0x28, 0x29 Cell Balancing Timers	78
5.14	System Faults and Status	79
5.14.1	0x63 Priority Fault	79
5.14.2	0x83 Priority Fault Mask	81
5.14.3	0x64 ETAUX Fault	81
5.14.4	0x84 ETAUX Fault Mask	83
5.14.5	0x65 Other Fault Register	83
5.14.6	0x85 Other Fault Mask	85
5.14.7	0x66 CB Status	85
5.14.8	0x86 CB Status Mask	86
5.14.9	0x67 Status	87
5.14.10	0x87 Status Mask	88
5.14.11	0x68-69 Open-Wire Status	88
5.14.12	0x88-89 Open-Wire Mask	89
<b>6.</b>	<b>Pin Functionality</b>	<b>90</b>
6.1	VCn Pins	90
6.2	CBn Pins	90
6.3	CSP and CSN Pins (24, 25)	91
6.4	VSS Pin (26)	92
6.5	AUX0/xT0, VTEMP, AUX1/xT1 Pins (27, 29, 28)	92
6.5.1	External Components	92
6.5.2	Aux Pins Open-Wire Test	93
6.6	Regulator and Supply Pins (30-33)	93

6.6.1	VCC Pin (30)	94
6.6.2	VDD Pin (31)	94
6.6.3	EMITTER Pin (32)	94
6.6.4	BASE Pin (33)	94
6.7	CMS0 and CMS1 Pins (34, 35)	94
6.8	DGND Pin (36)	94
6.9	V2P5 Pin (37)	94
6.10	$\overline{\text{RESET}}$ Pin (38)	94
6.11	$\overline{\text{WAKEUP}}$ Pin (39)	95
6.12	ALRT Pin (40)	95
6.13	ADDR/CS Pin (41)	95
6.14	SCL Pin (42)	95
6.15	MOSI Pin (43)	95
6.16	MISO/SDA/SINGLE-WIRE Pin (44)	95
6.17	GPIO(0-3) Pin (45-48)	96
6.18	LDMON Pin (49)	96
6.19	CFET and DFET Pins (50, 51)	97
6.19.1	DFET Pin (50)	98
6.19.2	CFET Pin (51)	98
6.20	VCPMP Pin (52)	99
6.21	VBAT2 Pin (53)	99
6.22	VBAT1 Pin (54)	100
<b>7.</b>	<b>System Operation</b>	<b>101</b>
7.1	0x2E Scan Operation	101
7.1.1	0x2E.7:6 System Mode	101
7.1.2	0x2E.5:3 Low Power Timer	101
7.1.3	0x2E.2:0 Scan Delay	101
7.2	System Modes	102
7.2.1	SHIP Mode	103
7.2.2	LOW POWER Mode	104
7.2.3	IDLE Mode	104
7.2.4	SCAN Mode	105
7.2.5	Scan Will Not Start	111
7.3	Open-Wire Function	112
7.4	Cell Balancing Examples	114
7.4.1	Automatic Cell Balancing	115
7.4.2	Manual Cell Balancing	117
7.5	Charge Pump	118
7.5.1	Charge Pump Ready State Machine	119
7.6	Trigger Bits	119
<b>8.</b>	<b>Communication Interface</b>	<b>120</b>
8.1	I <sup>2</sup> C Serial Interface	120
8.1.1	I <sup>2</sup> C Address	120
8.1.2	Protocol Conventions	121
8.1.3	Write Operation	121
8.1.4	Read Operation	122
8.1.5	I <sup>2</sup> C Timing	123
8.2	SPI Serial Interface	123

---

8.2.1	Identification Byte	124
8.2.2	Write Operation	124
8.2.3	Read Operation	125
8.2.4	CRC Calculation	127
8.2.5	SPI Timing	132
8.3	Single Wire Interface	133
8.3.1	Single Wire Address	133
8.3.2	Single Wire Read/Write Sequences	134
8.3.3	Single Wire Timing	135
<b>9.</b>	<b>Reduced Cell Count</b>	<b>137</b>
<b>10.</b>	<b>Revision History</b>	<b>139</b>
<b>11.</b>	<b>Package Outline Drawing</b>	<b>140</b>

# 1. Overview

## 1.1 Typical Application

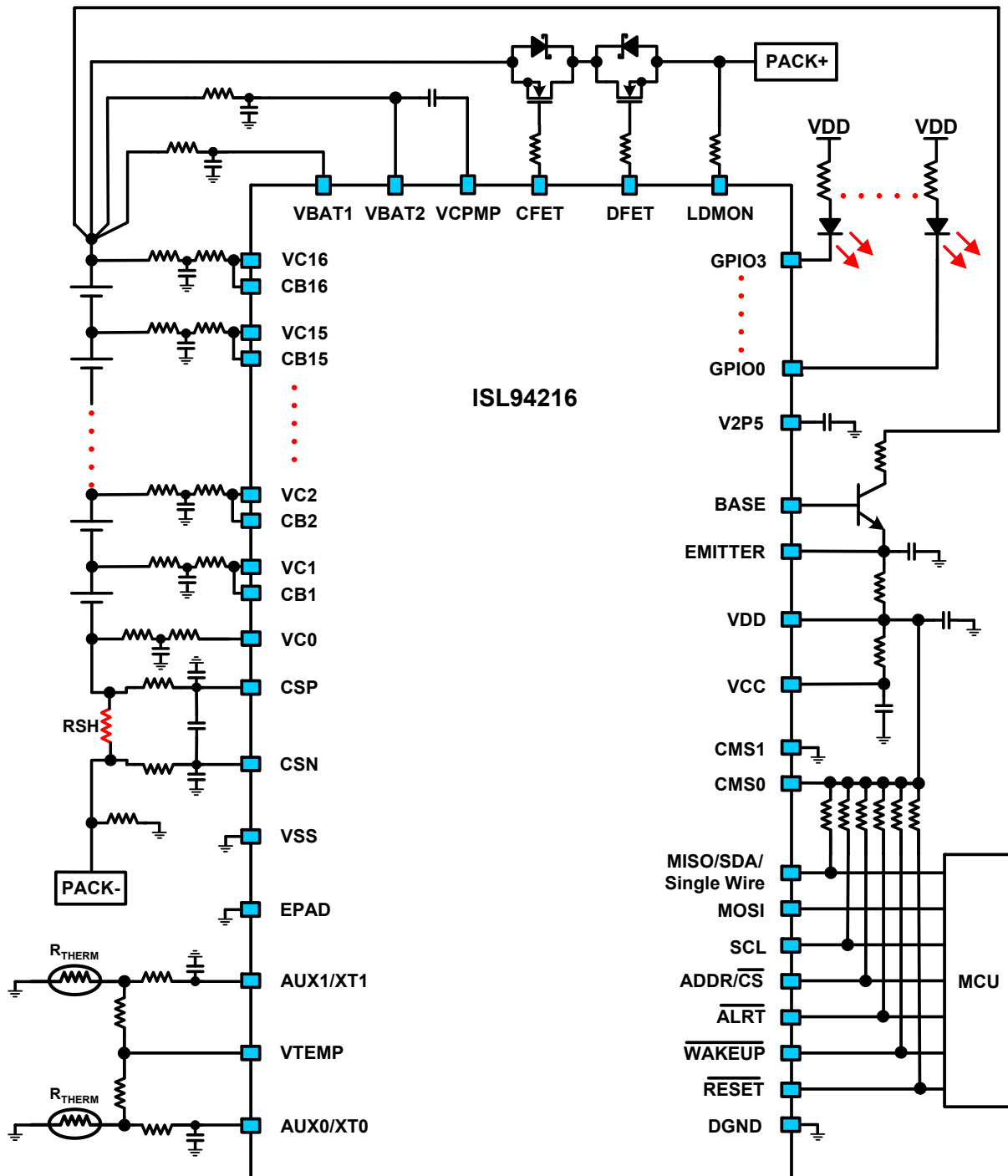

Figure 1. Typical Application

### 1.2 Block Diagram

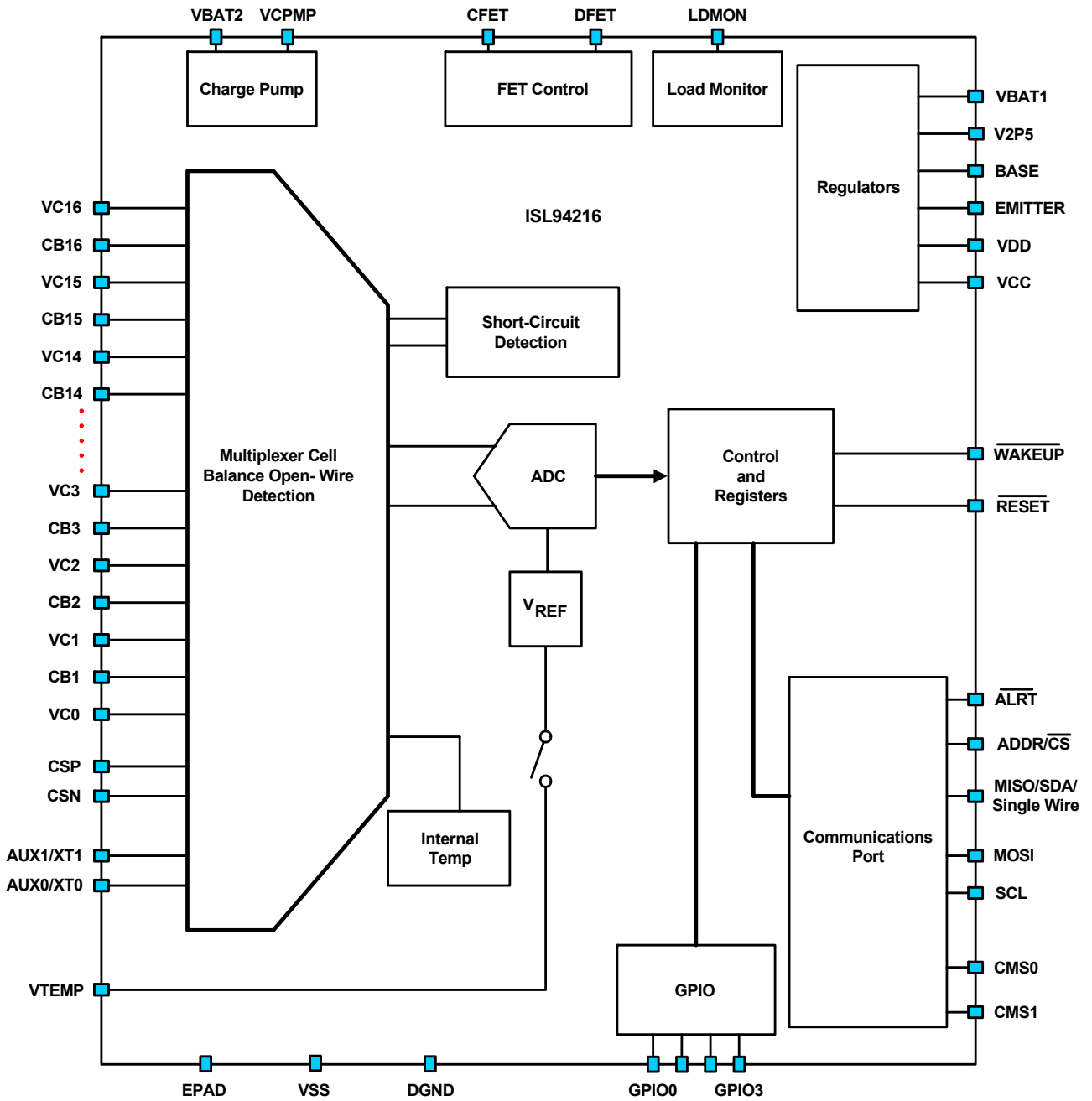

Figure 2. Block Diagram

### 1.3 Ordering Information

Part Number (Notes 2, 3)	Part Marking	Package (RoHS Compliant)	Pkg. Dwg. #	Carrier Type (Note 1)	Temp Range (°C)
ISL94216IRZ	ISL94216 IRZ	64 Ld QFN	L64.9x9B	Tray	-40 to +85
ISL94216IRZ-T				Reel, 3k	
ISL94216IRZ-T7				Reel, 1k	
ISL94216EVKIT1Z	Evaluation Kit				

**Notes:**

1. See [TB347](#) for details about reel specifications.
2. These Pb-free plastic packaged products employ special Pb-free material sets; molding compounds/die attach materials and NiPdAu-Ag plate - e4 termination finish, which is RoHS compliant and compatible with both SnPb and Pb-free soldering operations. Pb-free products are MSL classified at Pb-free peak re-flow temperatures that meet or exceed the Pb-free requirements of IPC/JEDEC J STD-020.
3. For Moisture Sensitivity Level (MSL), see the [ISL94216](#) product information page. For more information about MSL, see [TB363](#).

**Table 1. Key Differences Between Family of Parts**

Part Number	Cells Supported		Pack Voltage (Op)		Cell Bal.	Current Sense	Charge/Discharge FET			Supply Current (Typ)		Stand-Alone Capable	Internal ADC	Daisy Chain
	Min	Max	Min (V)	Max (V)			Control	Arrangement	Location	Normal	Sleep			
ISL94216	4	16	12	55	Both	Low Side	Yes	Both	Both (Note 4)	200µA	10µA	No	16b	No
ISL94212	6	12	6	60	Ext.	No	No	N/A	N/A	3.31mA	12µA	No	14b	Yes
ISL94208	4	6	8	26.4	Both	Low Side	Yes	Both	Low Side	850µA	2µA	No	No	No
ISL94202	3	8	4	36	Ext.	High Side	Yes	Both	High Side	348µA	13µA	State Machine	14b	No
RAJ240100	3	10	4	50	Int.	Low Side	Yes	Both	High Side	50µA	1µA	Int MCU	15b/ 18b	No
RAJ240090	3	8	4	50	Int.	Low Side	Yes	Both	High Side	50µA	1µA	Int MCU	15b/ 18b	No
RAJ240080	2	5	4	25	Both	Low Side	Yes	Both	High Side	50µA	1µA	Int MCU	15b/ 18b	No

**Note:**

4. GPIO can be configured to support low side C/DFETs.



## 2. Pin Information

### 2.1 Pin Assignments

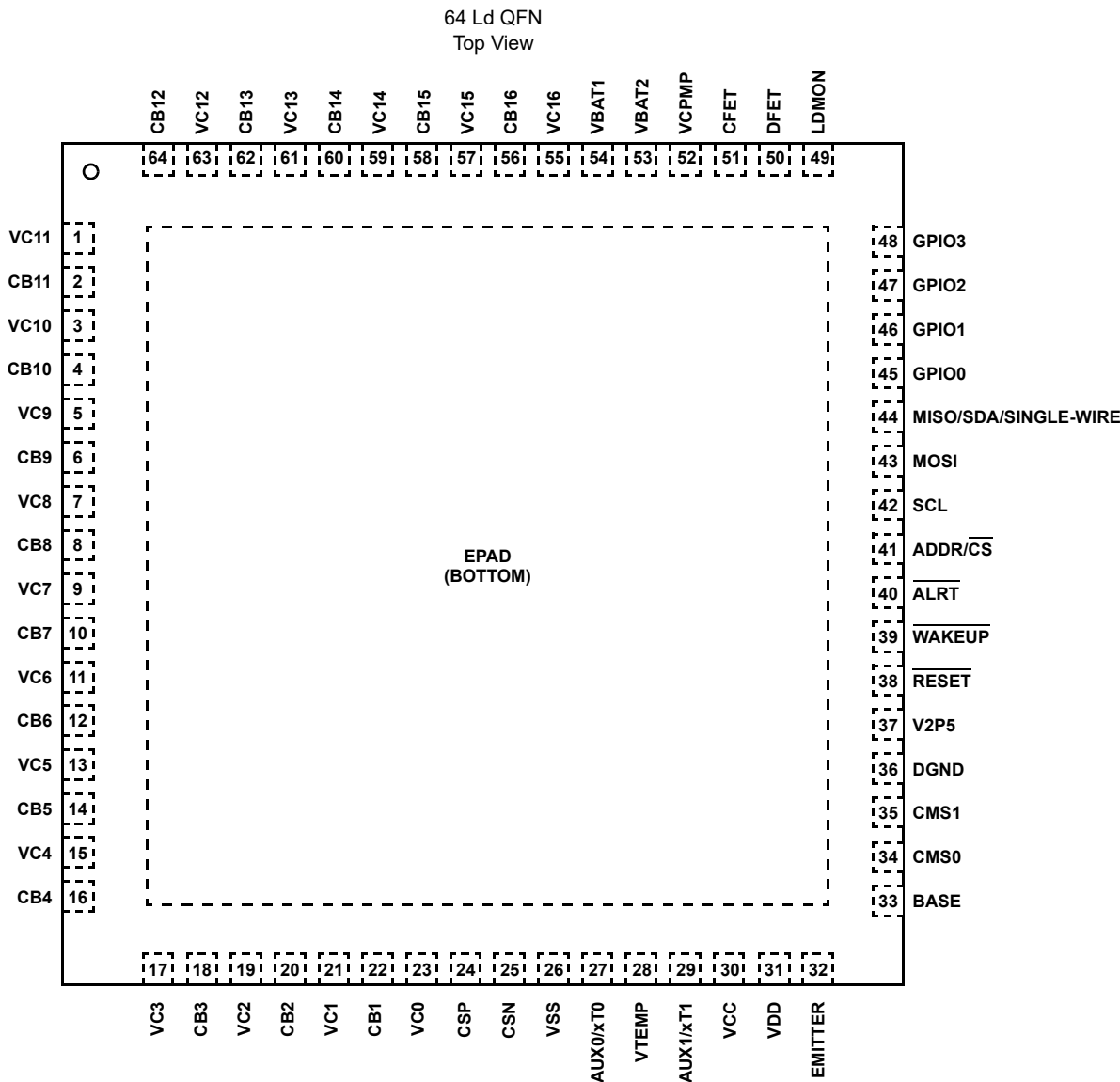

### 2.2 Pin Descriptions

Table 2. Pin Descriptions

Pin Number	Pin Name	Description
1, 3, 5, 7, 9, 11, 13, 15, 17, 19, 21, 23, 55, 57, 59, 61, 63	VCn (n = 0 to 16)	Battery cell voltage inputs. In an application with a 16-cell battery string, in which cell number 1 connects to the lowest voltage and cell number 16 connects to the highest voltage, VCn connects to the positive terminal of cell n and to the negative terminal of cell n+1 through external resistors (VC16 connects only to the positive terminal of Cell 16, VC0 only connects to the negative terminal of Cell 1). For applications with fewer than 16 cells, see <a href="#">Figure 130 on page 137</a> .
2, 4, 6, 8, 10, 12, 14, 16, 18, 20, 22, 56, 58, 60, 62, 64	CBn (n = 1 to 16)	Cell balancing pins. When external cell balancing FETs are used, each of these pins controls an external FET. When internal cell balancing FETs are used, these pins connect to the drains of the on-chip cell balancing transistors. See <a href="#">"Cell Balancing Registers" on page 73</a> .
24	CSP	Current sense positive input.
25	CSN	Current sense negative input.

**Table 2. Pin Descriptions (Continued)**

Pin Number	Pin Name	Description
26	VSS	Analog ground. Connect to the EPAD (electrical/thermal pad under the package).
27	AUX0/xT0	External temperature monitor or general purpose inputs. These inputs are intended for use with external resistor networks using NTC type thermistor sense elements, but can also be used as general purpose analog inputs at the user's discretion.
29	AUX1/xT1	
28	VTEMP	Reference voltage for off-chip temperature monitoring circuit. This is a switched output that supplies a reference voltage to external circuits that include thermistors. It is enabled before starting a measurement of pins AUX0/xT0, AUX1/xT1, or VTEMP itself. It is disconnected from the pin after the measurement completes.
30	VCC	3.3V analog supply voltage input. Connect to VDD using a 10Ω resistor and connect a 1μF capacitor between this pin and VSS.
31	VDD	3.3V digital supply voltage input. Connect directly or through a current sense resistor to the emitter of the external NPN transistor, connect through a 10Ω resistor to VCC. Connect a 1μF capacitor between this pin and DGND.
32	EMITTER	Regulator source current is calculated from the measured voltage between VDD and EMITTER pins. Connect this pin to the Emitter of the external NPN. Connect a regulator current sense resistor between the EMITTER and VDD pins. Connect a 1μF capacitor between this pin and DGND.
33	BASE	Regulator control pin. Connect to the external NPN transistor's base. Do not float.
34	CMS0	Communication protocol selection. Static input pins; do not change after power-up. See <a href="#">Table 77 on page 120</a> .
35	CMS1	
36	DGND	Digital ground.
37	V2P5	Internal 2.5V digital supply decoupling pin. Connect a 1μF capacitor between V2P5 and DGND.
38	$\overline{\text{RESET}}$	Active low reset digital input. Connect to a logic HIGH to enable the device. Connect to a logic LOW to reset the device to its Power-On Reset (POR) default state.
39	$\overline{\text{WAKEUP}}$	Active low wakeup digital input. Connect to a logic LOW voltage level to wake up the device and transition from SHIP or LOW POWER mode to IDLE mode.
40	$\overline{\text{ALRT}}$	Open-drain, active low alert output. It is asserted under a variety of conditions to interrupt a microcontroller. See <a href="#">"System Faults and Status" on page 79</a> .
41	$\overline{\text{ADDR/CS}}$	Chip Select input for SPI communication interface or address selection pin for I <sup>2</sup> C communications interface.
42	SCL	Serial clock input pin for both SPI and I <sup>2</sup> C communications interfaces.
43	MOSI	Master Output Slave Input for SPI communication interface.
44	MISO/SDA/ SINGLE-WIRE	Master Input Slave Output for SPI communication interface, or open-drain serial data I/O for I <sup>2</sup> C and Single Wire communication interfaces.
45	GPIO0	General purpose digital I/Os. Open drain when used as outputs. They can be used as general purpose inputs or outputs, as status LED drivers, or as part of FET driving circuits. See <a href="#">"0x12 ALRT and GPIO" on page 57</a> .
46	GPIO1	
47	GPIO2	
48	GPIO3	
49	LDMON	Load monitor input. This analog voltage monitor determines whether a normal load, short, or no load is connected to the battery pack. This pin is internally connected to the DFET pin when the DFET is off.
50	DFET	Drives the gate of an external NMOS that controls the current path between the battery pack and the load. This pin is internally connected to the LDMON pin when the DFET is off.
51	CFET	Drives the gate of an external NMOS that controls the current path between the battery pack and the charger. This pin is internally connected to the VBAT2 pin when the CFET is off.
52	VCPMP	Charge pump output voltage. Place a capacitor between VCPMP and VBAT2. The charge pump provides power to FET drivers and part of the cell balancing circuits.

**Table 2. Pin Descriptions (Continued)**

<b>Pin Number</b>	<b>Pin Name</b>	<b>Description</b>
53	VBAT2	Power supply pin. Connect to the most positive terminal of the battery pack through dedicated filter. This pin is internally connected to the CFET pin when the CFET is off.
54	VBAT1	Power supply pin. Connect to the most positive terminal of the battery pack through dedicated filter.
Bottom	EPAD	Analog ground. Metal pad under the package. Connect to the VSS pin and ground plane for thermal dissipation.

## 3. Specifications

### 3.1 Absolute Maximum Ratings

Parameter <a href="#">(Note 5)</a>	Minimum	Maximum	Unit
DGND	-0.5	+0.5	V
CSP, CSN, VC0	-1.0	+1.0	V
VBAT1, VBAT2, VCPMP	-0.5	+70	V
VCn (n = 13 to 16)	-0.5	+70	V
VCn (n = 9 to 12)	-0.5	+63	V
VCn (n = 6 to 8)	-0.5	+54	V
VCn (n = 2 to 5)	-0.5	+45	V
VC1	-0.5	+9	V
CBn (n = 13 to 16)	-0.5	+70	V
CBn (n = 9 to 12)	-0.5	+63	V
CBn (n = 6 to 8)	-0.5	+54	V
CBn (n = 2 to 5)	-0.5	+45	V
CB1	-1	+9	V
CBn [Internal Cell Balancing Current when active] <a href="#">(Note 7)</a>		±20	mA
CFET, DFET, V <sub>CPMP</sub> , LDMON <a href="#">(Note 7)</a>	-0.5	+70	V
CFET	V <sub>BAT2</sub> - 0.5	V <sub>BAT2</sub> + 12	V
DFET	LDMON - 0.5	V <sub>BAT2</sub> + 12	V
VCPMP	V <sub>BAT2</sub> - 1.0	V <sub>BAT2</sub> + 12	V
V2P5 <a href="#">(Note 7)</a>	-0.5	+2.9	V
BASE, EMITTER, VCC, VDD, VTEMP, Aux0/xT0, Aux1/xT1 <a href="#">(Note 7)</a>	-0.5	+6	V
SCL, S-WIRE/MISO/SDA, MOSI, ADDR/CS, GPIOx, CMS0, CMS1, ALRT, RESET, WAKEUP <a href="#">(Note 6)</a>	DGND - 0.5	DGND + 6	V
SDA/Single Wire, ALRT, GPIOx Pull-Down Current <a href="#">(Note 6)</a>		10	mA
<b>ESD Rating</b>		<b>Value</b>	<b>Unit</b>
Human Body Model (Tested per JS-001-2014)		1.5	kV
Charged Device Model (Tested per JS-002-2014)		750	V
Latch-Up (Tested per JESD78E; Class 2, Level A)		100	mA

**Notes:**

- All voltages are specified with respect to VSS, unless otherwise noted.
- ALRT, GPIO0, GPIO2, GPIO3 (configure as an output) and MISO/SDA/SINGLE-WIRE (operating as an output) pins are digital outputs. These pins should not be driven from an external source.
- V<sub>CPMP</sub>, CFET, DFET, CB[1:16], V2P5, VTEMP, and BASE pins are analog outputs and should not be driven from an external source. VCC and VDD can be driven only by the external NPN connected to the BASE and EMITTER pins.

**CAUTION:** Do not operate at or near the maximum ratings listed for extended periods of time. Exposure to such conditions can adversely impact product reliability and result in failures not covered by warranty.

### 3.2 Thermal Information

Thermal Resistance (Typical)	$\theta_{JA}$ (°C/W)	$\theta_{JC}$ (°C/W)
64 Ld QFN (Notes 8, 9)	24	1.1

**Notes:**

8.  $\theta_{JA}$  is measured in free air with the component mounted on a high-effective thermal conductivity test board with direct attach features. See [TB379](#).
9. For  $\theta_{JC}$ , the case temperature location is the center of the exposed metal pad on the package underside.

Parameter	Minimum	Maximum	Unit
Maximum Continuous Power Dissipation		400	mW
Maximum Storage Temperature Range	-55	+125	°C
Maximum Junction Temperature ( $T_{JMAX}$ )		+125	°C
Pb-Free Reflow Profile	see <a href="#">TB493</a>		

### 3.3 Recommended Operation Conditions

Parameter	Minimum	Maximum	Unit
Ambient Temperature Range ( $T_A$ )	-40	+85	°C
Junction Temperature ( $T_J$ )	-40	+125	°C
$V_{BAT1}$ , $V_{BAT2}$	12	55	V
DFET, CFET, VCPMP	$V_{BAT2}$	66	V
CFET, DFET	$V_{BAT2}$	$V_{BAT2} + 11$	V
VCPMP	$V_{BAT2}$	$V_{BAT2} + 11$	V
LDMON	0	$V_{BAT2}$	V
$VC(n+1) - VC(n)$ (n = 0 to 15)	2.2	4.7	V
$CB(n+1) - VC(n)$ (n = 0 to 15)	0	6	V
VC0	-600	300	mV
$CB(n)$ (n = 1 to 16) ( <a href="#">Note 7</a> )	$VC_{(n-1)}$	$VC_{(n-1)} + 5$	V
CSN, DGND	-10	+10	mV
(CSP - CSN) [Current Measurement]	-600	+300	mV
VTEMP, AUX0/xT0, AUX1/xT1	0	1.22	V
EMITTER - $V_{DD}$	0	275	mV
SDA/Single Wire, $\overline{ALRT}$ , GPIOx Pull Down Current ( <a href="#">Note 6</a> )		2.5	mA
GPIOx, $\overline{ALRT}$ , $\overline{MOSI}$ , $\overline{MISO}$ /SDA/SINGLE-WIRE, $\overline{SCL}$ , $\overline{ADDR/CS}$ , CMS0, CMS1, WAKEUP, RESET ( <a href="#">Note 6</a> )	0	$V_{DD}$	V

### 3.4 Electrical Specifications

Unless otherwise specified:  $T_A = +25^\circ\text{C}$ ,  $V_{\text{BAT1}} = V_{\text{BAT2}} = 48\text{V}$ ,  $(V_{\text{Cn}} - V_{\text{Cn-1}}) = 3\text{V}$ ,  $V_{\text{CC}} = V_{\text{DD}} = 3.3\text{V}$ , control registers at default,  $V_{\text{SS}} = \text{DGND} = 0\text{V}$ , cell balancing is off. Voltages are with respect to  $V_{\text{SS}}$ . External components are per ["Pin Functionality" on page 90](#).

Parameter	Symbol	Test Conditions	Min (Note 10)	Typ	Max (Note 10)	Unit
<b>Power Supply</b> ( <a href="#">"System Operation" on page 101</a> )						
$V_{\text{BAT}}$ Voltage Range	$V_{\text{BAT1}}, V_{\text{BAT2}}$	For $V_{\text{BAT1}}, V_{\text{BAT2}}$	12		55	V
Total Average Current Consumed at $V_{\text{BAT1}}, V_{\text{BAT2}}, V_{\text{DD}}$ , and VCC Pins	$I_{\text{total}}$	IDLE Mode; Charge Pump On	250	330	380	$\mu\text{A}$
		IDLE Mode; Charge Pump Off	200	290	340	$\mu\text{A}$
		SCAN Mode; Charge Pump and FETs on, Current during VCell Scan	600	820	1000	$\mu\text{A}$
		SCAN Mode; Charge Pump and FETs off, Current during VCell Scan	540	760	940	$\mu\text{A}$
		LOW POWER Mode; Strong Reg on; LP REG = 1		39	200	$\mu\text{A}$
		LOW POWER Mode; Weak Reg on; LP REG = 0		10	50	$\mu\text{A}$
		SHIP Mode		5	18	$\mu\text{A}$
<b>Cell Measurement</b> ( <a href="#">"0x30 - 0x4F V<sub>CELL</sub> Voltage (R)" on page 45</a> )						
$V_{\text{CELL}}$ Measurement Error	$V_{\text{CELLME}}$	$0^\circ\text{C}$ to $+60^\circ\text{C}$ ; 3V to 4.5V, Register 0x02 = 0x9C, 14 cell configuration at 4.5V.	-10	$\pm 5$	10	mV
$V_{\text{CELL}}$ Input Leakage Current		Not Scanning	-0.3		0.3	$\mu\text{A}$
<b>I<sub>PACK</sub> Functional Block</b> ( <a href="#">"0x52 - 0x53 I<sub>PACK</sub> Voltage (R)" on page 46</a> ) (Note 11)						
$I_{\text{PACK}}$ Measurement Gain Error	$I_{\text{PACK\_GE}}$	$V_{\text{CSP}} = \pm 200\text{mV}$ 0x03 = 0x9C	-0.3		0.3	%
$I_{\text{PACK}}$ Measurement Gain Error TC	$I_{\text{PACK\_GE\_TC}}$	$T = -40^\circ\text{C}$ to $+85^\circ\text{C}$ 0x03 = 0x9C		$\pm 30$		ppm/ $^\circ\text{C}$
$I_{\text{PACK}}$ Measurement Offset vs Common-Mode	$I_{\text{PACK\_CMRR}}$	$V_{\text{CMV}} = \pm 163.84\text{mV}$ 0x03 = 0x9C		$\pm 1.6$		$\mu\text{V}/\text{V}$
$I_{\text{PACK}}$ Measurement Offset	$I_{\text{PACK\_VOS}}$	0x03 = 0x9C	-100	10	+100	$\mu\text{V}$
$I_{\text{PACK}}$ Measurement Offset TC	$I_{\text{PACK\_VOS\_TC}}$	$T = -40^\circ\text{C}$ to $+85^\circ\text{C}$ 0x03 = 0x9C		$\pm 0.3$		$\mu\text{V}/^\circ\text{C}$
$I_{\text{PACK}}$ Input Current	$I_{\text{PACK\_IC}}$	$V_{\text{CSP}} = V_{\text{CSN}}$	-15	1	+15	$\mu\text{A}$
		$T = -40^\circ\text{C}$ to $+85^\circ\text{C}$		0.001		$\mu\text{A}/^\circ\text{C}$
$I_{\text{PACK}}$ Offset Current	$I_{\text{os\_IC}}$	$I_{\text{CSP}} - I_{\text{CSN}}$	-7.5	0.005	+7.5	$\mu\text{A}$
		$T = -40^\circ\text{C}$ to $+85^\circ\text{C}$		0.001		$\mu\text{A}/^\circ\text{C}$
Zero Current Threshold	$I_{\text{Zero\_THR}}$	Zero current threshold for charge and discharge		$\pm 200$		$\mu\text{V}$
<b>Short-Circuit Detectors</b> ( <a href="#">"I<sub>PACK</sub> Fault Detectors" on page 49</a> )						
Discharge Short-Circuit Hysteresis	$\text{SC}_{\text{DCHRG\_Hys}}$			40		mV
Discharge Short-Circuit $V_{\text{OS}}$	$\text{SC}_{\text{DCHRG\_Vos}}$	Difference between setting and trigger voltage		8		mV

Unless otherwise specified:  $T_A = +25^\circ\text{C}$ ,  $V_{BAT1} = V_{BAT2} = 48\text{V}$ ,  $(V_{C_n} - V_{C_{n-1}}) = 3\text{V}$ ,  $V_{CC} = V_{DD} = 3.3\text{V}$ , control registers at default,  $V_{SS} = \text{DGND} = 0\text{V}$ , cell balancing is off. Voltages are with respect to  $V_{SS}$ . External components are per ["Pin Functionality" on page 90](#).  
(Continued)

Parameter	Symbol	Test Conditions	Min (Note 10)	Typ	Max (Note 10)	Unit
<b>Load Monitor Function (<a href="#">"0x0E Load/Charge Operations" on page 52</a>)</b>						
Load Detection Threshold	$V_{LDThr}$		0.9	1.2	1.6	V
Load Detection Hysteresis	$V_{LDHys}$			100		mV
Load Monitor Pull-Up Resistance	$R_{LDPU}$	From LDMON to VBAT1 ELD[1:0] = 01	0.75	1	1.2	M $\Omega$
		From LDMON to VBAT1 ELD[1:0] = 10	8	10	13.5	k $\Omega$
Load Monitor External Isolation Resistor (see <a href="#">"Block Diagram of Power FET Controls" on page 70</a> )	$R_{LDiso}$		200			$\Omega$
Load Monitor Enable Delay Time	$t_{LDEN}$	DFET off to load detection test		256		ms
<b>External Temperature Measurements (<a href="#">"ETAUX Detectors" on page 59</a>)</b>						
$V_{ETAUX}$ Gain Error	$V_{ETAUX\_GE}$	0V to FS	-1	$\pm 0.2$	+1	%
$V_{ETAUX}$ Gain Error TC	$V_{ETAUX\_GE\_TC}$	0V to FS		$\pm 35$		ppm/ $^\circ\text{C}$
$V_{ETAUX}$ Gain Error Match	$V_{ETAUX\_GE\_M}$	0V to FS		$\pm 0.25$		%
$V_{ETAUX}$ Offset	$V_{ETAUX\_VOS}$	$V_{ETAUX} = 0\text{V}$		-3		mV
$V_{ETAUX}$ Offset TC	$V_{ETAUX\_VOSTC}$			$\pm 22$		$\mu\text{V}/^\circ\text{C}$
Maximum Capacitor Connected to xT0, xT1 ( <a href="#">Figure 87 on page 56</a> )	$C_{ETAUX}$	NTC = 10k $\Omega$			22	nF
		NTC = 100k $\Omega$			3.9	nF
Settling Time for VTEMP before a xT0, xT1 measurement	$t_{ETAUX\_settle}$	$V_{TEMP}$ Turn on to xT0, xT1 measurement	3.35	4		ms
ETAUX Pull-Up Resistor	$R_{ETAUX}$	OW Test Internal pull-up resistors from xT0 and xT1 to VCC (AUX PULL = 1).		1.3		M $\Omega$
ETAUX Input Current	$I_{ETAUX}$		-1	0.01	+1	$\mu\text{A}$
		T = $-40^\circ\text{C}$ to $85^\circ\text{C}$		0.001		$\mu\text{A}/^\circ\text{C}$
ETAUX Open-Wire Threshold	$ETAUX_{owThr}$			1.146		V
<b>Internal Temperature Sensor (<a href="#">"Internal Temperature" on page 61</a>)</b>						
Internal Temperature Sensor Measurement Range	IT		-40		+85	$^\circ\text{C}$
Internal Temperature Sensor Output Code		$25^\circ\text{C}$		0x99		Bits
Internal Temperature Sensor Resolution	$IT_{STEP}$	$25^\circ\text{C}$		0.85		$^\circ\text{C}/\text{LSB}$
Internal Temperature Error	$IT_{ER}$	$0^\circ\text{C}$ to $+60^\circ\text{C}$		$\pm 5$		$^\circ\text{C}$
<b>Regulator and VTEMP (<a href="#">"Regulator Measurements and Detectors" on page 62</a>)</b>						
Regulation Voltage Accuracy	$REG_V$	At VDD Pin, no external load	3.15	3.3	3.45	V
Capacitance at the Regulator	$REG_C$		1			$\mu\text{F}$
$V_{TEMP}$ Voltage Accuracy		0mA to 2mA load	1.189		1.221	V
$V_{TEMP}$ Output Impedance				0.2		$\Omega$
Weak Reg Voltage at VDD		SHIP or LOW POWER Mode, No Load, LP REG = 0	2.65	2.89		V

Unless otherwise specified:  $T_A = +25^\circ\text{C}$ ,  $V_{\text{BAT1}} = V_{\text{BAT2}} = 48\text{V}$ ,  $(V_{\text{Cn}} - V_{\text{Cn-1}}) = 3\text{V}$ ,  $V_{\text{CC}} = V_{\text{DD}} = 3.3\text{V}$ , control registers at default,  $V_{\text{SS}} = \text{DGND} = 0\text{V}$ , cell balancing is off. Voltages are with respect to  $V_{\text{SS}}$ . External components are per ["Pin Functionality" on page 90](#).  
(Continued)

Parameter	Symbol	Test Conditions	Min (Note 10)	Typ	Max (Note 10)	Unit
Weak Reg Drive Current Capability		SHIP or LOW POWER Mode, LP REG = 0		150		$\mu\text{A}$
BASE Pin Drive Current capability (Ext regulator NPN base drive only)	$I_{\text{BASE\_drv}}$	LP REG = 1	1			mA
$V_{\text{VCC}}$ Measurement Error	$V_{\text{VCC\_ME}}$			-2.0		%
$V_{\text{VTEMP}}$ Measurement Error	$V_{\text{VTEMP\_ME}}$			-0.25		%
$I_{\text{REG}}$ Measurement Gain Error	$I_{\text{REG\_GE}}$	EMITTER = $V_{\text{DD}} + 50\text{mV}$ to $V_{\text{DD}} + 200\text{mV}$		0.025		%
$I_{\text{REG}}$ Measurement Offset	$I_{\text{REG\_VOS}}$				280	$\mu\text{V}$
Time to Switch from Strong Regulator to Weak (Internal) Regulator	$t_{\text{REGSW}}$	Device transitions to SHIP or LOW POWER Modes		2.048		s
<b>Regulator and <math>V_{\text{TEMP}}</math> Thresholds (<a href="#">"Regulator Measurements and Detectors" on page 62</a>)</b>						
Voltage Threshold for $V_{\text{TEMP}}$	$V_{\text{TEMP\_Min}}$			1.1		V
$V_{\text{CC}}$ and $V_{\text{DD}}$ Overvoltage Threshold	$PG_{\text{VDD\_OV}}$ , $PG_{\text{VCC\_OV}}$			3.83		V
$V_{\text{CC}}$ and $V_{\text{DD}}$ Undervoltage Threshold	$PG_{\text{VDD\_UV}}$ , $PG_{\text{VCC\_UV}}$			2.58		V
$V_{2\text{P5}}$ Overvoltage Threshold	$PG_{2\text{P5V\_OV}}$			2.84		V
$V_{2\text{P5}}$ Undervoltage Threshold	$PG_{2\text{P5V\_UV}}$			1.94		V
<b>VBAT1 (<a href="#">"0x20 - 0x21 VBAT1 Thresholds" on page 68</a>)</b>						
$V_{\text{BAT1}}$ Measurement Error	$V_{\text{BAT1\_ME}}$	$25\text{V} \leq V_{\text{BAT1}} \leq 55\text{V}$ (0C to 60C)		$\pm 0.5$		%
$V_{\text{BAT1}}$ Measurement Error TC	$V_{\text{BAT1ME\_TC}}$			$\pm 100$		ppm/ $^\circ\text{C}$
$V_{\text{BAT1}}$ Input Resistance	$R_{\text{VBAT1}}$			640		k $\Omega$
<b>Cell Balancing (<a href="#">"Cell Balancing Registers" on page 73</a>)</b>						
External Cell Balance Drive Current	$I_{\text{ECB}}$	CB Config = 1; $\text{CB}_n$ output on ( $n = 1$ to 16)	21		28	$\mu\text{A}$
External Cell Balance Leakage Current	$I_{\text{ECB\_OFF}}$	CB Config = 1; $\text{CB}_n$ output off ( $n = 1$ to 16)		10		nA
Internal Cell Balance Pin Resistance $\text{CB}_n$ to $\text{VC}_{n-1}$ ( $n = 1$ to 16)	$R_{\text{CB\_OFF}}$ , $R_{\text{CB\_ON}}$	CB Config= 0; $\text{CB}_n$ output off ( $n = 1$ to 16)		4		M $\Omega$
		CB Config= 0; $\text{CB}_n$ output on ( $n = 1$ to 16)		70		$\Omega$
CB Threshold Hysteresis	$V_{\text{CBHys}}$			90		mV
<b>FET Drive Control Specifications (<a href="#">"Power FET Block" on page 70</a>)</b>						
Average Output Voltage with Respect to $V_{\text{BAT2}}$ at DFET and CFET Pins	$V_{\text{DFET}}$ , $V_{\text{CFET}}$	$12\text{V} \leq V_{\text{BAT2}} \leq 55\text{V}$ ; (100uA load on Charge Pump)	8		12	V
Charge Pump Rising Voltage Threshold (To clear CPMP NRDY bit 0x65.5)	$V_{\text{pmpMin}}$	$V_{\text{BAT2}}$ recommended operating range		11		V
Charge Pump Falling Voltage Threshold (To set CPMP NRDY bit 0x65.5)	$V_{\text{pmpFall}}$	$V_{\text{BAT2}}$ recommended operating range		5.6		V
DFET Off-State Output Resistance	$R_{\text{DFOFF}}$	Resistance from DFET to LDMON, VCMP on		70		$\Omega$
CFET Off-State Output Resistance	$R_{\text{CFOFF}}$	Resistance from CFET to $V_{\text{BAT2}}$ VCMP on		70		$\Omega$



Unless otherwise specified:  $T_A = +25^\circ\text{C}$ ,  $V_{\text{BAT1}} = V_{\text{BAT2}} = 48\text{V}$ ,  $(V_{\text{Cn}} - V_{\text{Cn-1}}) = 3\text{V}$ ,  $V_{\text{CC}} = V_{\text{DD}} = 3.3\text{V}$ , control registers at default,  $V_{\text{SS}} = \text{DGND} = 0\text{V}$ , cell balancing is off. Voltages are with respect to  $V_{\text{SS}}$ . External components are per ["Pin Functionality" on page 90](#).  
(Continued)

Parameter	Symbol	Test Conditions	Min (Note 10)	Typ	Max (Note 10)	Unit
DFET On-State Output Resistance	$R_{\text{DFON}}$	Resistance from DFET to VPMP, VCMP on		2800		$\Omega$
CFET On-State Output Resistance	$R_{\text{CFON}}$	Resistance from CFET to VPMP, VCMP on		2800		$\Omega$
Charge Pump-to-Gate Capacitance Ratio (External FETs)	$C_{\text{pmp}}$	$C_{\text{pmp}}$ to $(C_{\text{DFET}} + C_{\text{CFET}})$ Ratio	20			Ratio
Charge Pump External Current Load Capacity	$I_{\text{pmp}}$	Both $C_{\text{FET}}$ and $D_{\text{FET}}$ on	200			$\mu\text{A}$
Charge Pump Start-Up Time	$t_{\text{strt}}$	$C_{\text{pmp}} = 470\text{nF}$ ; the time it takes to charge $C_{\text{pmp}}$ to 10V above $V_{\text{BAT2}}$		13	30	ms
<b>Open-Wire (See <a href="#">"Open-Wire Test" on page 110</a>)</b>						
Open-Wire Resistance	$R_{\text{OW}}$	$V_{\text{Cn}}$ to $V_{\text{Cn-1}}$ ( $n = 1$ to $16$ )		8		$\text{k}\Omega$
Open-Wire Resistance Connection Time	$t_{\text{OW}}$			10		ms
Open-Wire Detection Threshold	$V_{\text{OWth1}}$	$V_{\text{Cn}}$ to $V_{\text{Cn-1}}$ ( $n = 1$ to $16$ )		0.5		V
$V_{\text{BAT1}}$ Open-Wire Detection Threshold	$V_{\text{OWth2}}$	$V_{\text{C16}} - V_{\text{BAT1}}$		0.3		V
VSS Open-Wire Detection Threshold	$V_{\text{OWth3}}$	$V_{\text{C1}} - V_{\text{SS}}$ , $V_{\text{C0}} - V_{\text{SS}}$		0.25		V
Input Capacitance	$C_{\text{OW}}$	Equivalent capacitor that can be connected to the pin			200	nF
<b>System (<a href="#">"System Operation" on page 101</a>)</b>						
First Conversion ADC Conversion Time	$\text{ADC}_{\text{CT1}}$	ADC input changes or a new trigger executes		2		ms
ADC Subsequent Conversion Time	$\text{ADC}_{\text{CT2}}$			0.5		ms
Communication Time Out <a href="#">"0x1B.7:6 Communications Timeout" on page 63</a>	$t_{\text{COM}}$	Maximum time allowed without receiving communication from the Host while in IDLE mode		4.096		s
LOW POWER Measurement period	$t_{\text{LPMEAS}}$	Time between scans in LOW POWER Mode		2.048		s
Internal 32kHz Oscillator Accuracy			-5	$\pm 1$	+5	%
Internal 4MHz Oscillator Accuracy				3		%
<b>GPIO (<a href="#">"0x12 ALRT and GPIO" on page 57</a>)</b>						
GPIO Pins Low Level Output Voltage	$\text{GPIO}_{\text{VOL}}$	$I_{\text{sink}} = 2\text{mA}$		0.2	0.4	V
GPIO Pin High Level Input Voltage	$\text{GPIO}_{\text{VIH}}$		$0.7 \times V_{\text{DD}}$			V
GPIO Pin Low Level Input Voltage	$\text{GPIO}_{\text{VIL}}$				$0.3 \times V_{\text{DD}}$	V
GPIO Pull-up	$R_{\text{GPIO\_PU}}$		2500			$\Omega$
GPIO Pins Leakage Current High	$\text{GPIO}_{\text{LIH}}$	3.3V applied	-1		+1	$\mu\text{A}$
GPIO Pins Pulse Period	$\text{GPIO}_{\text{pulse\_per}}$	LED Drive mode		10		ms
GPIO Pins On-Time (Low)	$\text{GPIO}_{\text{pulse\_on}}$	LED Drive mode		2		ms
<b>CS/ADDR, CMS0, CMS1</b>						
Pins High Level Input Voltage	$\text{PIN}_{\text{VIH}}$		$0.7 \times V_{\text{DD}}$			V
Pins Low Level Input Voltage	$\text{PIN}_{\text{VIL}}$				$0.3 \times V_{\text{DD}}$	V
Pins Leakage Current	$\text{PIN}_{\text{LIH}}$	0V to 3.3V applied	-1		+1	$\mu\text{A}$

Unless otherwise specified:  $T_A = +25^\circ\text{C}$ ,  $V_{\text{BAT1}} = V_{\text{BAT2}} = 48\text{V}$ ,  $(V_{\text{C}_n} - V_{\text{C}_{n-1}}) = 3\text{V}$ ,  $V_{\text{CC}} = V_{\text{DD}} = 3.3\text{V}$ , control registers at default,  $V_{\text{SS}} = \text{DGND} = 0\text{V}$ , cell balancing is off. Voltages are with respect to  $V_{\text{SS}}$ . External components are per ["Pin Functionality" on page 90](#).  
(Continued)

Parameter	Symbol	Test Conditions	Min (Note 10)	Typ	Max (Note 10)	Unit
<b>ALRT</b> ( <a href="#">"ALRT Pin (40)" on page 95</a> )						
ALRT Pin Low Level Output Voltage	$\overline{\text{ALRT}}_{\text{VOL}}$	$I_{\text{sink}} = 2\text{mA}$		0.2	0.4	V
ALRT Sink Current	$\overline{\text{ALRT}}_{\text{IOL}}$	At 0.6V		4		mA
ALRT Pin Leakage Current	$\overline{\text{ALRT}}_{\text{LIH}}$		-1		+1	$\mu\text{A}$
ALRT Pin Pulse Period	$\overline{\text{ALRT}}_{\text{pulse\_per}}$	$\overline{\text{ALRT}}$ Pulse EN = 1		10		ms
ALRT Pin On-Time	$\overline{\text{ALRT}}_{\text{pulse\_on}}$	$\overline{\text{ALRT}}$ Pulse EN = 1		2		ms
<b>WAKEUP</b> ( <a href="#">"WAKEUP Pin (39)" on page 95</a> )						
WAKEUP Pin High Level Input Voltage	$\overline{\text{WK}}_{\text{VIH}}$		$0.7 \times V_{\text{DD}}$			V
WAKEUP Pin Low Level Input Voltage	$\overline{\text{WK}}_{\text{VIL}}$				$0.3 \times V_{\text{DD}}$	V
WAKEUP Pin Leakage Current	$\overline{\text{WK}}_{\text{LIH}}$	0V to 5.5V applied	-1		+1	$\mu\text{A}$
WAKEUP Low state pulse width	$\overline{\text{WK}}_{\text{LPw}}$	Minimum detectable pulse width	100			ns
<b>RESET</b> ( <a href="#">"RESET Pin (38)" on page 94</a> )						
RESET Pin High Level Input Voltage	$\overline{\text{RST}}_{\text{VIH}}$		$0.7 \times V_{\text{DD}}$			V
RESET Pin Low Level Input Voltage	$\overline{\text{RST}}_{\text{VIL}}$				$0.3 \times V_{\text{DD}}$	V
RESET Pin Leakage Current High	$\overline{\text{RST}}_{\text{LIH}}$	0V to 5.5V applied	-1		+1	$\mu\text{A}$
Power-On Reset Voltage at VBAT1 (Hysteresis 100mV Minimum)	$V_{\text{POR}}$		4		7	V
Power-On Reset Startup Time to Measurement	$t_{\text{StartUp}}$	$V_{\text{BAT1}} > V_{\text{POR}}$ , $\overline{\text{RESET}}$ rising edge or soft reset to first measurement command			20	ms
Power-On Reset Communication Lockout	$t_{\text{RESET}}$	$V_{\text{BAT1}} > V_{\text{POR}}$ , $\overline{\text{RESET}}$ rising edge or soft reset to first serial communication command activity (ACK)		200		$\mu\text{s}$
RESET Low State Pulse Width	$\overline{\text{RST}}_{\text{LPw}}$		100			ns
<b>SPI Interface Specifications</b> ( <a href="#">"SPI Serial Interface" on page 123</a> )						
Slave Address (7bits) No CRC	$\text{SA}_{\text{SPI}}$	Fixed		0001 010		Binary
Slave Address (7bits) Use CRC	$\text{SA}_{\text{SPI}}$	Fixed		1001 110		Binary
SCLK, MOSI, $\overline{\text{CS}}$ Input Lo Voltage	$\text{SPI}_{\text{VIL}}$				$0.2 \times V_{\text{DD}}$	V
SCLK, MOSI, $\overline{\text{CS}}$ Input Hi Voltage	$\text{SPI}_{\text{VIH}}$		$0.8 \times V_{\text{DD}}$			V
SCLK, MOSI, $\overline{\text{CS}}$ Input Hysteresis	$\text{SPI}_{\text{VHYS}}$			$0.05 \times V_{\text{DD}}$		mV
SCLK, MOSI, $\overline{\text{CS}}$ Input Current	$\text{SPI}_{\text{IIN}}$		-1		+1	$\mu\text{A}$
SCLK, MOSI, $\overline{\text{CS}}$ Input Capacitance	$\text{SPI}_{\text{CIN}}$				10	pF
MISO Output Lo Voltage	$\text{SPI}_{\text{VOL}}$	2mA Sink Current	0		0.4	V
MISO Output Hi Voltage	$\text{SPI}_{\text{VOH}}$	2mA Source Current	$V_{\text{DD}} - 0.4\text{V}$		$V_{\text{DD}}$	V
SCL Clock Frequency	$\text{SPI}_{\text{fSCL}}$				2	MHz
Pulse Width of Input Spikes Suppressed	$\text{SPI}_{\text{tIN1}}$	Any pulse narrower than the max spec is suppressed			50	ns
Clock High Time	$\text{SPI}_{\text{tHIGH}}$		200			ns
Clock Low Time	$\text{SPI}_{\text{tLOW}}$		200			ns

Unless otherwise specified:  $T_A = +25^\circ\text{C}$ ,  $V_{\text{BAT1}} = V_{\text{BAT2}} = 48\text{V}$ ,  $(V_{\text{Cn}} - V_{\text{Cn-1}}) = 3\text{V}$ ,  $V_{\text{CC}} = V_{\text{DD}} = 3.3\text{V}$ , control registers at default,  $V_{\text{SS}} = \text{DGND} = 0\text{V}$ , cell balancing is off. Voltages are with respect to  $V_{\text{SS}}$ . External components are per ["Pin Functionality" on page 90](#).  
(Continued)

Parameter	Symbol	Test Conditions	Min (Note 10)	Typ	Max (Note 10)	Unit
Enable Lag Time	SPI_t <sub>LAG</sub>	Last data read clock edge to chip select high	250			ns
Time Delay Between Bytes	SPI_t <sub>WAIT</sub>	Time between falling edge of the clock pulse corresponding to the last bit of any byte, and the next rising edge of the clock corresponding to the first bit of the next byte	7			μs
Slave Access Time	SPI_T <sub>LEAD</sub>	Chip select low to SCLK rising edge			200	ns
Data Valid Time	SPI_t <sub>V</sub>	Clock low to MISO valid		130	350	ns
Data Output Hold Time	SPI_t <sub>HO</sub>	Data hold time after falling edge of SCL	0	115		ns
MISO Disable Time	SPI_t <sub>DIS</sub>	MISO disabled following rising edge of $\overline{\text{CS}}$			240	ns
Data Setup Time	SPI_t <sub>SU</sub>	Data input valid before rising edge of SCL	100			ns
Data Input Hold Time	SPI_t <sub>HI</sub>	Data input to remain valid following rising edge of SCL	80			ns
MOSI Rise Time	SPI_t <sub>R</sub>	Up to 50pF load			30	ns
MOSI Fall Time	SPI_t <sub>F</sub>	Up to 50pF load			30	ns
<b>I<sup>2</sup>C Interface Specifications</b> ( <a href="#">"I<sup>2</sup>C Serial Interface" on page 120</a> )						
Slave Address (7bits)	SA <sub>I2C</sub>	$\overline{\text{CS}}/\text{Addr} = \text{VDD}$		0011 010		Binary
		$\overline{\text{CS}}/\text{Addr} = \text{DGND}$		0001 010		Binary
SDA and SCL Input Buffer LOW Voltage	V <sub>IL</sub>		-0.3		0.3xV <sub>DD</sub>	V
SDA and SCL Input Buffer HIGH Voltage	V <sub>IH</sub>		0.7xV <sub>DD</sub>		V <sub>DD</sub> +0.3	V
SDA and SCL Input Buffer Hysteresis	Hysteresis			0.05xV <sub>DD</sub>		V
SDA Output Buffer LOW Voltage	V <sub>OL</sub>	Sinking 2mA	0	0.02	0.4	V
Pin Leakage Current for SDA and SCL Pins	I <sub>leak</sub>		-1		1	μA
SCL Frequency	f <sub>SCL</sub>				400	kHz
Pulse Width Suppression Time at SDA and SCL Inputs	t <sub>IN</sub>	Any pulse narrower than the Max value is suppressed			50	ns
SCL Falling Edge to SDA Output Data Valid	t <sub>AA</sub>	SCL falling edge crossing 30% of V <sub>DD</sub> , until SDA exits the 30% to 70% of V <sub>DD</sub> window			900	ns
Time the Bus Must be Free Before the Start of a New Transmission	t <sub>BUF</sub>	SDA crossing 70% of V <sub>DD</sub> during a STOP condition, to SDA crossing 70% of V <sub>DD</sub> during the following START condition	1300			ns
Clock LOW Time	t <sub>LOW</sub>	Measured at the 30% of V <sub>DD</sub> crossing	1300			ns
Clock HIGH Time	t <sub>HIGH</sub>	Measured at the 70% of V <sub>DD</sub> crossing	600			ns

Unless otherwise specified:  $T_A = +25^\circ\text{C}$ ,  $V_{\text{BAT1}} = V_{\text{BAT2}} = 48\text{V}$ ,  $(V_{\text{C}_n} - V_{\text{C}_{n-1}}) = 3\text{V}$ ,  $V_{\text{CC}} = V_{\text{DD}} = 3.3\text{V}$ , control registers at default,  $V_{\text{SS}} = \text{DGND} = 0\text{V}$ , cell balancing is off. Voltages are with respect to  $V_{\text{SS}}$ . External components are per ["Pin Functionality" on page 90](#).  
(Continued)

Parameter	Symbol	Test Conditions	Min (Note 10)	Typ	Max (Note 10)	Unit
Eighth Bit to ACK Bit Delay (Applies to reading ADC Output Data Only)	$I^2C\_t_{\text{WAIT}}$	Time between the rising edge of the clock pulse corresponding to the last bit of any byte, and the falling edge of the clock pulse corresponding to the Acknowledge bit	7			$\mu\text{s}$
START Condition Setup Time	$t_{\text{SU:STA}}$	SCL rising edge to SDA falling edge. Both crossing 70% of $V_{\text{DD}}$	600			ns
START Condition Hold Time	$t_{\text{HD:STA}}$	From SDA falling edge crossing 30% of $V_{\text{DD}}$ to SCL falling edge crossing 70% of $V_{\text{DD}}$	600			ns
Input Data Setup Time	$t_{\text{SU:DAT}}$	From SDA exiting the 30% to 70% of $V_{\text{DD}}$ window, to SCL rising edge crossing 30% of $V_{\text{DD}}$	100			ns
Input Data Hold Time	$t_{\text{HD:DAT}}$	From SCL falling edge crossing 30% of $V_{\text{DD}}$ to SDA entering the 30% to 70% of $V_{\text{DD}}$ window	20		900	ns
STOP Condition Setup Time	$t_{\text{SU:STO}}$	From SCL rising edge crossing 70% of $V_{\text{DD}}$ , to SDA rising edge crossing 30% of $V_{\text{DD}}$	600	17		ns
STOP Condition Hold Time	$t_{\text{HD:STO}}$	From SDA rising edge to SCL falling edge. Both crossing 70% of $V_{\text{DD}}$	600	45		ns
Output Data Hold Time	$t_{\text{DH}}$	From SCL falling edge crossing 30% of $V_{\text{DD}}$ , until SDA enters the 30% to 70% of $V_{\text{DD}}$ window	0	150		ns
SDA and SCL Rise Time	$t_{\text{R}}$	From 30% to 70% of $V_{\text{DD}}$	$20 + 0.1 \times C_b$		300	ns
SDA and SCL Fall Time	$t_{\text{F}}$	From 70% to 30% of $V_{\text{DD}}$	$20 + 0.1 \times C_b$		300	ns
Capacitive Loading of SDA or SCL	$C_b$	Total on-chip and off-chip	10		400	pF
SDA and SCL Bus Pull-Up Resistor Off-Chip	$R_{\text{PU}}$	Maximum is determined by $t_{\text{R}}$ and $t_{\text{F}}$ For $C_b = 400\text{pF}$ , max is about $2\text{k}\Omega \sim 2.5\text{k}\Omega$ For $C_b = 40\text{pF}$ , max is about $15\text{k}\Omega \sim 20\text{k}\Omega$	1	4.7		$\text{k}\Omega$

**Single Wire Interface Specifications** (["Single Wire Interface" on page 133](#)) **Notes 13, 14, and 15**

Slave Address (7 bits)	$SA_{\text{SW}}$	$\overline{\text{CS}}/\text{Addr} = V_{\text{DD}}$		0011 010		Binary
		$\overline{\text{CS}}/\text{Addr} = \text{DGND}$		0001 010		Binary
Single Wire Input Low Voltage	$V_{\text{SWIL}}$		0.0		$0.3 \times V_{\text{DD}}$	V
Single Wire Input High Voltage	$V_{\text{SWIH}}$		$0.7 \times V_{\text{DD}}$		5.5	V
Output Buffer LOW Voltage	$V_{\text{OL}}$	$I_{\text{OL}} = 2\text{mA}$	0	0.02	0.4	V
Voltage Hysteresis	$V_{\text{hys}}$	$I_{\text{OL}} = 2\text{mA}$	$0.05 \times V_{\text{DD}}$			V
Pin Leakage Current	$I_{\text{leak}}$				1	$\mu\text{A}$

Unless otherwise specified:  $T_A = +25^\circ\text{C}$ ,  $V_{\text{BAT1}} = V_{\text{BAT2}} = 48\text{V}$ ,  $(V_{\text{C}_n} - V_{\text{C}_{n-1}}) = 3\text{V}$ ,  $V_{\text{CC}} = V_{\text{DD}} = 3.3\text{V}$ , control registers at default,  $V_{\text{SS}} = \text{DGND} = 0\text{V}$ , cell balancing is off. Voltages are with respect to  $V_{\text{SS}}$ . External components are per ["Pin Functionality" on page 90](#).  
(Continued)

Parameter	Symbol	Test Conditions	Min (Note 10)	Typ	Max (Note 10)	Unit
Single Wire Pin Capacitance	$C_{\text{PINSW}}$				10	pF
Capacitive Loading of Single Wire	$C_{\text{bSW}}$	Total on-chip and off-chip	10		200	pF
Single Wire Bus Pull-Up Resistor Off-Chip	$R_{\text{PUSW}}$	Max is determined by $t_{\text{R}}$ , $t_{\text{F}}$ and differences in master vs slave IO Supply voltages (if any)	1	4.7		k $\Omega$
Rise Time	$t_{\text{rSW}}$	30% to 70% of $V_{\text{DD}}$			150	ns
Fall Time	$t_{\text{fSW}}$	70% to 30% of $V_{\text{DD}}$			150	ns
Time Out if the Voltage at Single Wire stays LOW	$t_{\text{TOLSW}}$		300			$\mu\text{s}$
Time out if the Voltage at Single Wire stays HIGH	$t_{\text{TOHSW}}$		35			ms
Glitch Filtering	$t_{\text{glitch}}$	Pulses narrower than Min are ignored	50			ns
<b>Transmitter Single Wire Timing Specifications</b>						
Hold Low Time	$t_{\text{HLDSW}}$	The time the line is held low by the master after a falling edge	2			$\mu\text{s}$
Pulse-Width of Not Present (NACK), Read 1, or Write 1	$t_{1\text{NPresSW}}$		2		3	$\mu\text{s}$
Pulse-Width of Present (ACK), Read 0, or Write 0	$t_{0\text{PresSW}}$		5		7.6	$\mu\text{s}$
Pulse-Width of Reset (Start)	$t_{\text{RstSW}}$		100		150	$\mu\text{s}$
Falling edge of a 1 or Not Present to next symbol's falling edge	$t_{1\text{BPSW}}$		5			$\mu\text{s}$
Falling edge of a 0 or Present to next symbol's falling edge	$t_{0\text{BPSW}}$		12			$\mu\text{s}$
Pulse-Width of Load (Stop)	$t_{\text{LdSW}}$		12		18	
Falling edge of a Load to next symbol's falling edge	$t_{\text{LdBPSW}}$		40			$\mu\text{s}$
Falling edge of a Reset to next symbol's falling edge	$t_{\text{RstBPSW}}$		250			$\mu\text{s}$
Time out if the Voltage at Single Wire stays LOW	$t_{\text{TOLSW}}$		300			$\mu\text{s}$
Time out if the Voltage at Single Wire stays HIGH	$t_{\text{TOHSW}}$		40			ms
<b>Receiver Single Wire Timing Specifications</b>						
Narrow Pulse-Width Threshold for Not Present (NACK) or "1"	$t_{\text{DetNSW}}$		1.0		1.8	$\mu\text{s}$
Wide Pulse-Width Threshold for Not Present (NACK) or "1", and Narrow Pulse-Width Threshold for Present (ACK) or "0"	$t_{\text{DetWSW}}$		3.2		4.8	$\mu\text{s}$
Wide Pulse-Width Threshold for Present (ACK) or "0", and Narrow Pulse-Width Threshold for Load (Stop)	$t_{\text{Det0LdSW}}$		7.8		11.8	$\mu\text{s}$
Wide Pulse-Width Threshold for Load (Stop), and Narrow Pulse-Width Threshold for Reset (Start)	$t_{\text{DetLdRstSW}}$		20		30	$\mu\text{s}$

Unless otherwise specified:  $T_A = +25^\circ\text{C}$ ,  $V_{\text{BAT1}} = V_{\text{BAT2}} = 48\text{V}$ ,  $(V_{\text{C}_n} - V_{\text{C}_{n-1}}) = 3\text{V}$ ,  $V_{\text{CC}} = V_{\text{DD}} = 3.3\text{V}$ , control registers at default,  $V_{\text{SS}} = \text{DGND} = 0\text{V}$ , cell balancing is off. Voltages are with respect to  $V_{\text{SS}}$ . External components are per ["Pin Functionality" on page 90](#).  
(Continued)

Parameter	Symbol	Test Conditions	Min ( <a href="#">Note 10</a> )	Typ	Max ( <a href="#">Note 10</a> )	Unit
Wide Pulse-Width Threshold for Reset (Start), and $t_{\text{TOLSW}}$ Detection Threshold	$t_{\text{DetRstTOLSW}}$		160		240	$\mu\text{s}$
$t_{\text{TOHSW}}$ Detection Threshold	$t_{\text{DetTOHSW}}$		33		37	ms

**Notes:**

- Compliance to datasheet limits is assured by one or more of the following methods: production test, characterization, and design. Recommended external components are listed in ["Pin Functionality" on page 90](#).
- Also see ["CSP and CSN Pins \(24, 25\)" on page 91](#) for typical circuit.
- Applies to all measurements except for VTEMP, xT0, and xT1 that wait for VTEMP settling.
- Drivers are open drain.  $V_{\text{DD}}$  is the power supply of the chip's digital IOs.
- Pulse widths measured from the  $0.3 \times V_{\text{CC}}$  crossing during the falling edge to the  $0.7 \times V_{\text{CC}}$  crossing during the rising edge.
- Timing selected to work with clock tolerances up to  $\pm 20\%$  at both the master and the slave.
- Values are for calculation purposes only and are not test limits. See the register descriptions in section 4 for details.

### 4. Typical Performance Curves

$T_A = +25^\circ\text{C}$ ,  $V_{BAT1} = V_{BAT2} = 48\text{V}$ ,  $(V_{Cn} - V_{Cn-1}) = 3\text{V}$ ,  $V_{CC} = V_{DD} = 3.3\text{V}$ , averages = 1,  $V_{SS} = \text{DGND} = 0\text{V}$ , unless otherwise specified. Cell balancing is off.

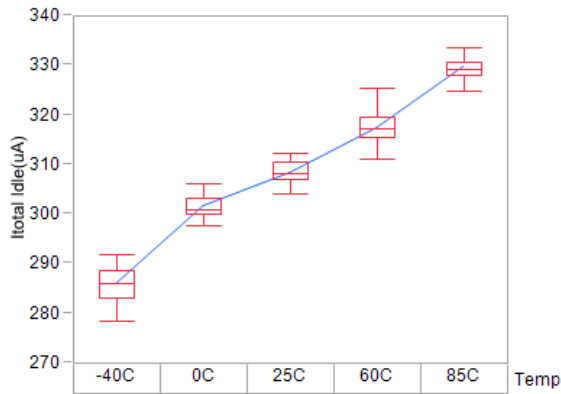

Figure 3.  $I_{TOT}$  IDLE Mode

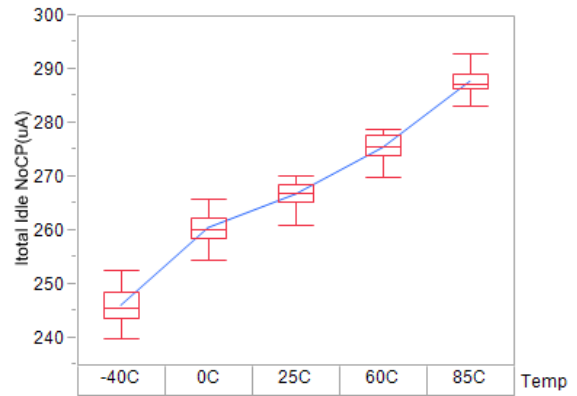

Figure 4.  $I_{TOT}$  IDLE Mode, CP off

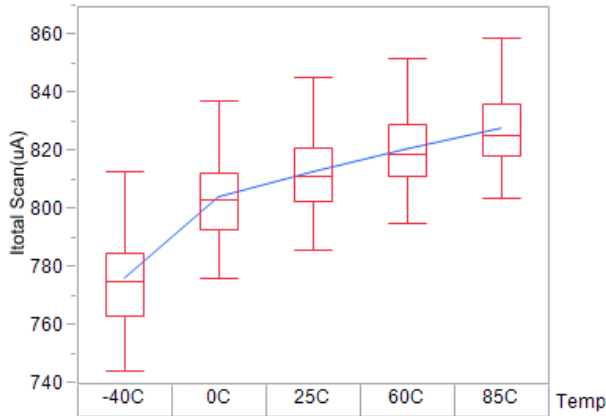

Figure 5.  $I_{TOT}$  SCAN Mode

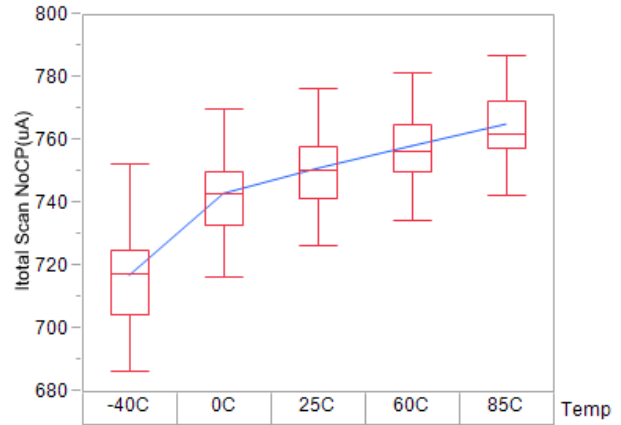

Figure 6.  $I_{TOT}$  SCAN Mode, CP Off

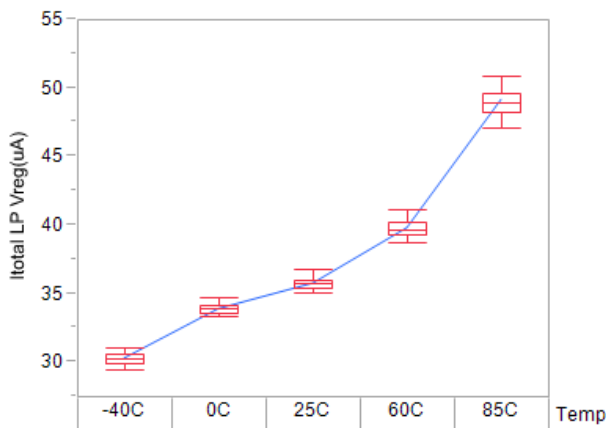

Figure 7.  $I_{TOT}$  LP Mode, LP Reg = 1

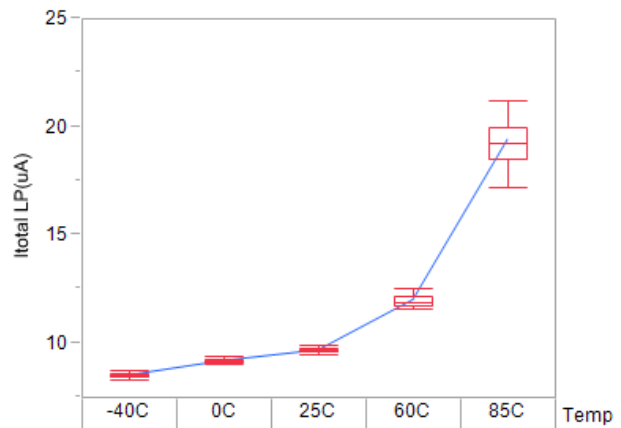

Figure 8.  $I_{TOT}$  LP Mode, LP Reg = 0

$T_A = +25^{\circ}\text{C}$ ,  $V_{BAT1} = V_{BAT2} = 48\text{V}$ ,  $(V_{Cn} - V_{Cn-1}) = 3\text{V}$ ,  $V_{CC} = V_{DD} = 3.3\text{V}$ , averages = 1,  $V_{SS} = \text{DGND} = 0\text{V}$ , unless otherwise specified. Cell balancing is off. (Continued)

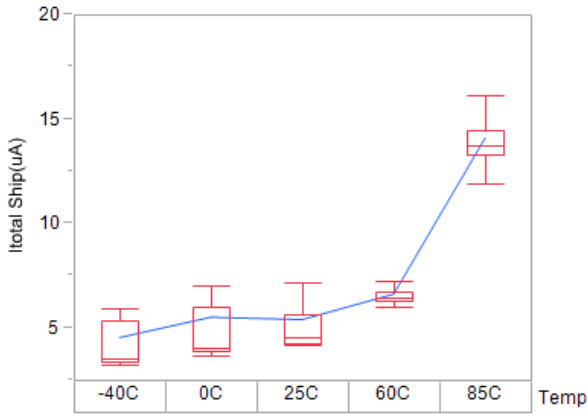

Figure 9.  $I_{TOT}$  SHIP Mode, LP Reg = 0

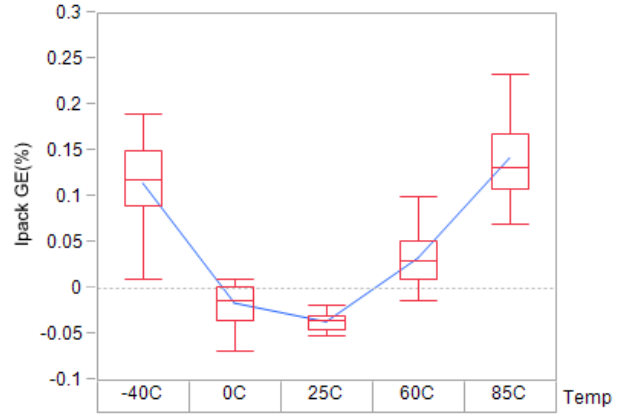

Figure 10.  $I_{PACK}$  Measurement Gain Error

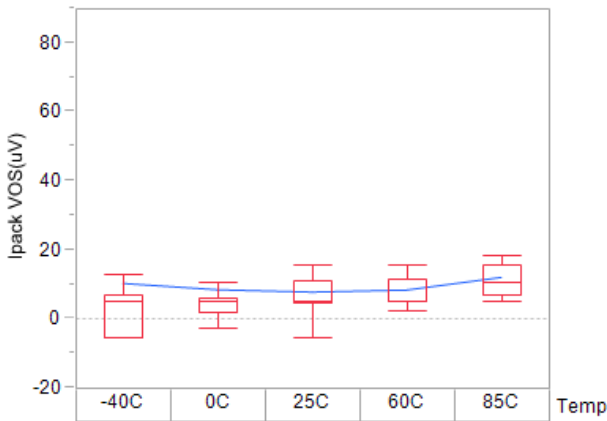

Figure 11.  $I_{PACK}$  Measurement Offset Voltage

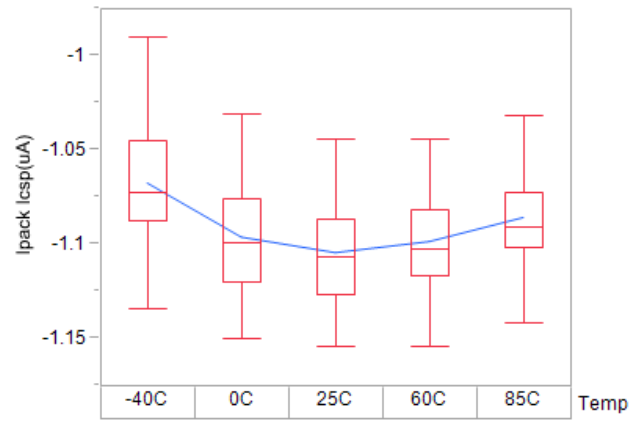

Figure 12.  $I_{CSP}$  Pin Measurement Input Current

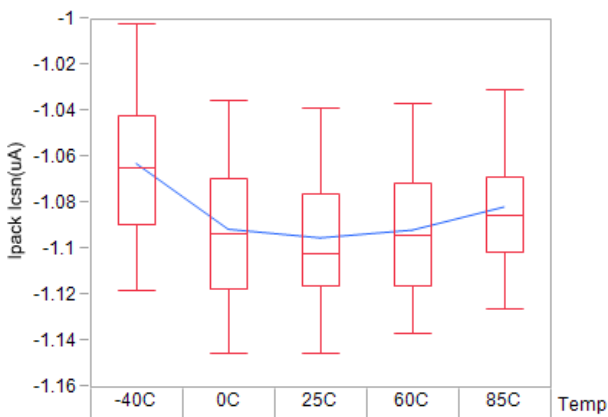

Figure 13.  $I_{CSN}$  Pin Measurement Input Current

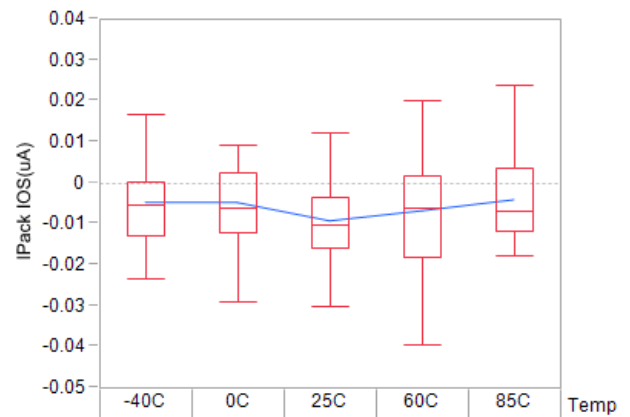

Figure 14.  $I_{PACK}$  Measurement Offset Current



$T_A = +25^\circ\text{C}$ ,  $V_{BAT1} = V_{BAT2} = 48\text{V}$ ,  $(V_{Cn} - V_{Cn-1}) = 3\text{V}$ ,  $V_{CC} = V_{DD} = 3.3\text{V}$ , averages = 1,  $V_{SS} = \text{DGND} = 0\text{V}$ , unless otherwise specified. Cell balancing is off. (Continued)

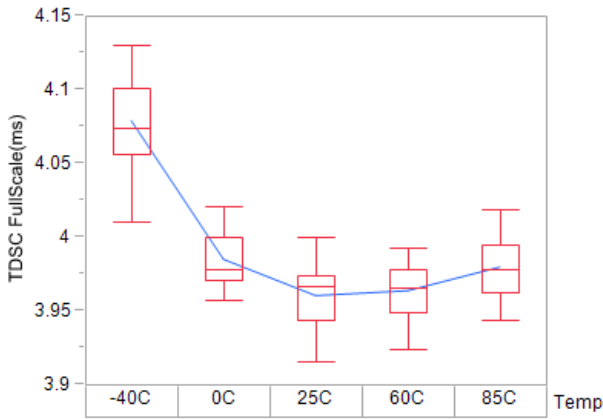

Figure 15. DSC Delay, Maximum Setting

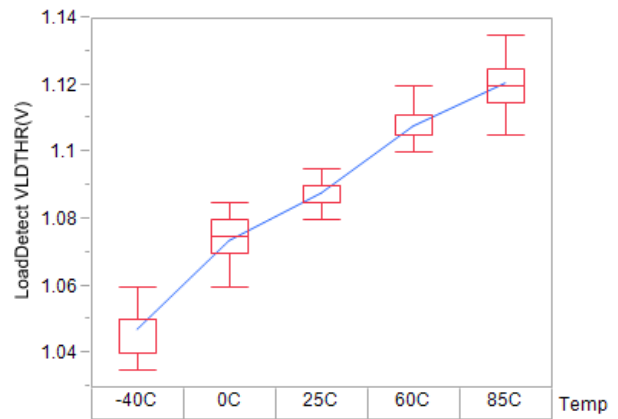

Figure 16. Load Detection Threshold

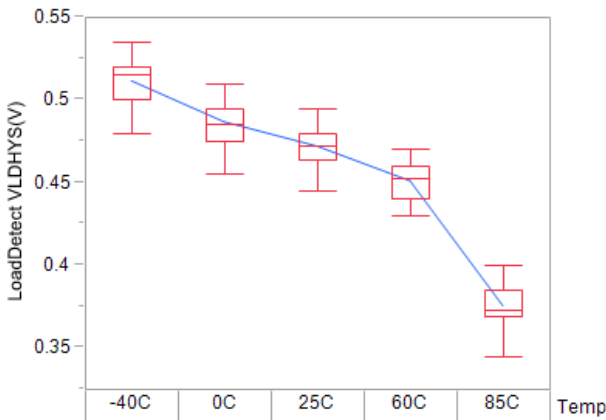

Figure 17. Load Detection Hysteresis

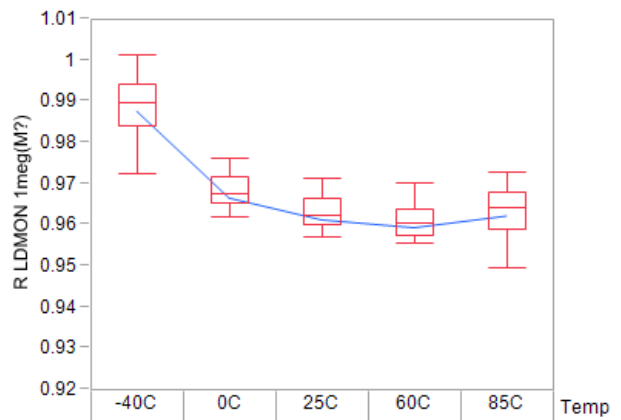

Figure 18. Load Monitor Pull-Up, ELD[1:0] = 01

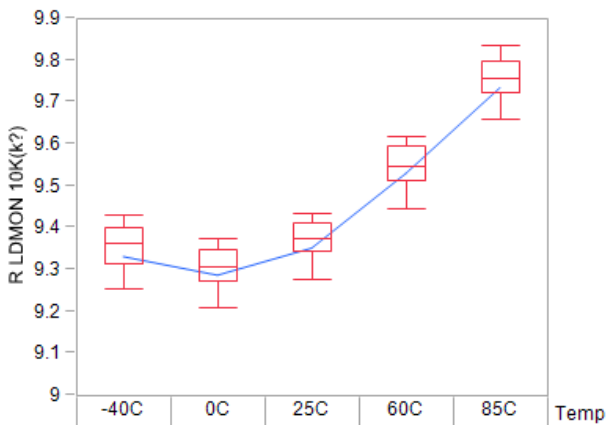

Figure 19. Load Monitor Pull-Up, ELD[1:0] = 10

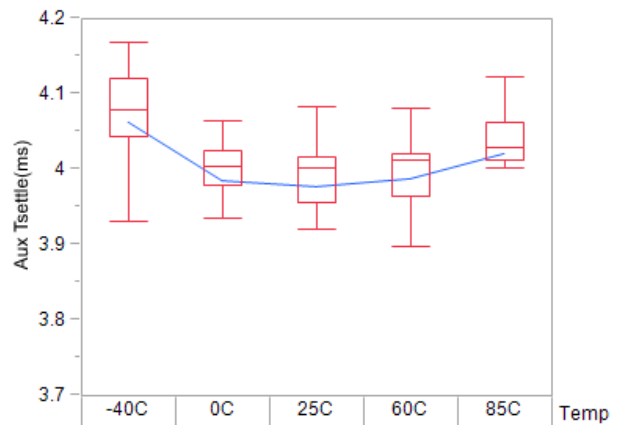

Figure 20.  $V_{TEMP}$  Settling Time

$T_A = +25^{\circ}\text{C}$ ,  $V_{BAT1} = V_{BAT2} = 48\text{V}$ ,  $(V_{C_n} - V_{C_{n-1}}) = 3\text{V}$ ,  $V_{CC} = V_{DD} = 3.3\text{V}$ , averages = 1,  $V_{SS} = \text{DGND} = 0\text{V}$ , unless otherwise specified. Cell balancing is off. (Continued)

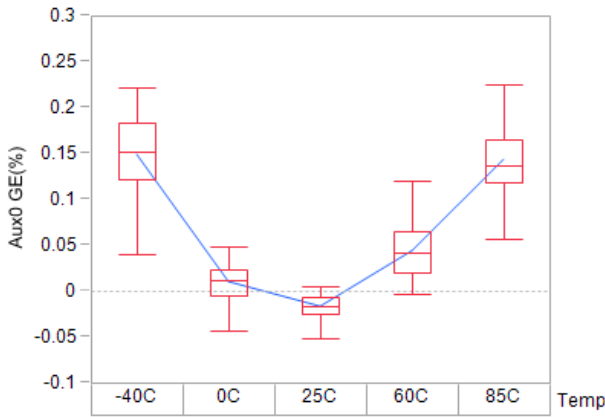

Figure 21. AUX0/xT0 Gain Error

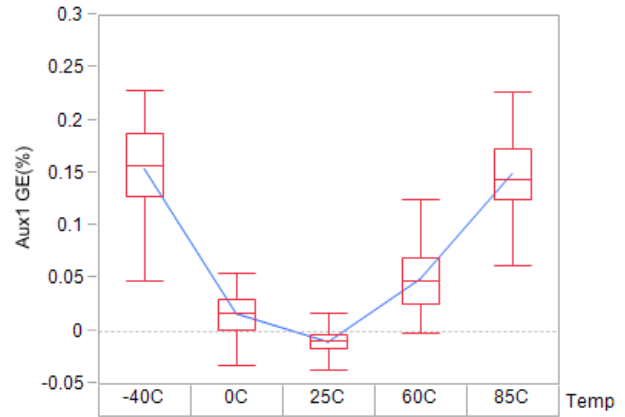

Figure 22. AUX1/xT1 Gain Error

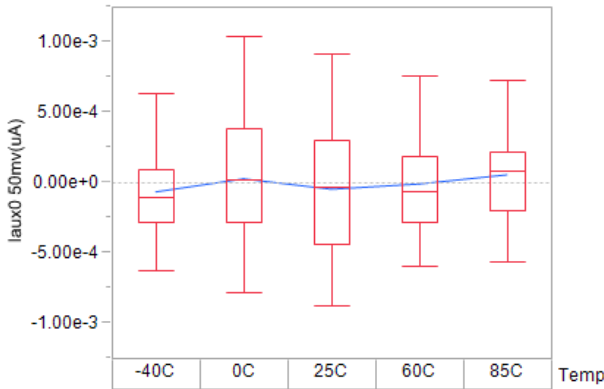

Figure 23. AUX0/xT0 Pin Input Current at 50mV

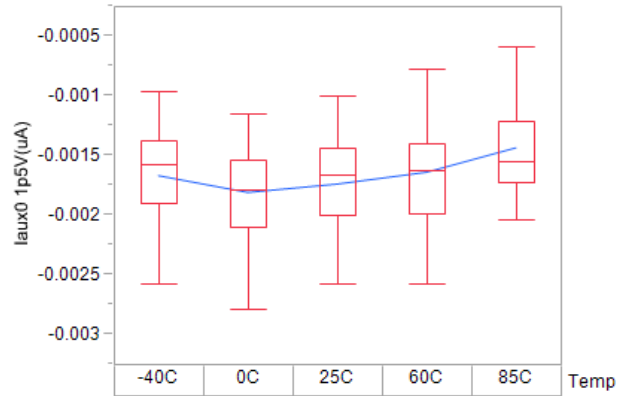

Figure 24. AUX0/xT0 Pin Input Current at 1.5V

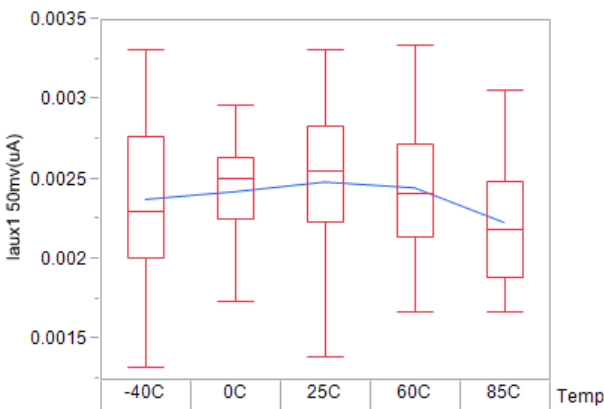

Figure 25. AUX1/xT1 Pin Input Current at 50mV

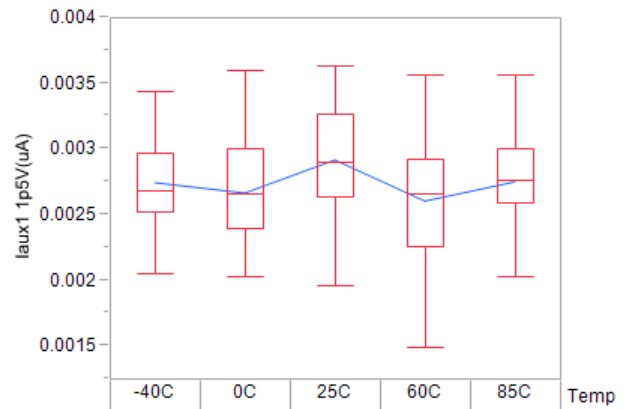

Figure 26. AUX1/xT1 Pin Input Current at 1.5V

$T_A = +25^\circ\text{C}$ ,  $V_{BAT1} = V_{BAT2} = 48\text{V}$ ,  $(V_{C_n} - V_{C_{n-1}}) = 3\text{V}$ ,  $V_{CC} = V_{DD} = 3.3\text{V}$ , averages = 1,  $V_{SS} = \text{DGND} = 0\text{V}$ , unless otherwise specified. Cell balancing is off. (Continued)

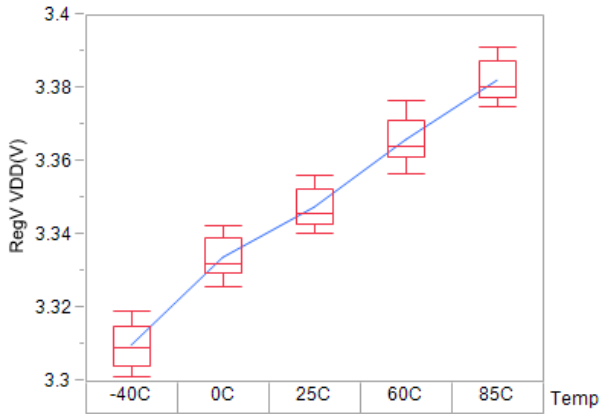

Figure 27. Regulation Voltage Accuracy

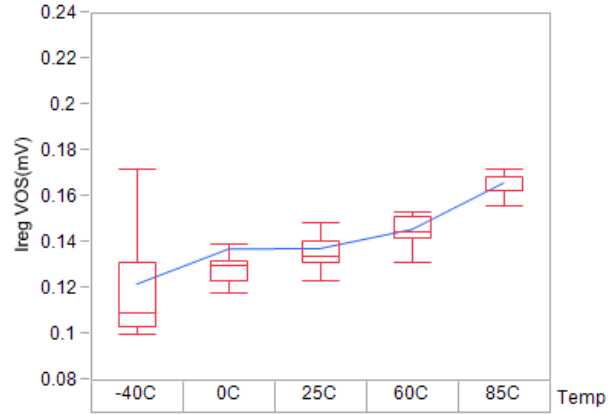

Figure 28.  $I_{REG}$  Measurement Offset

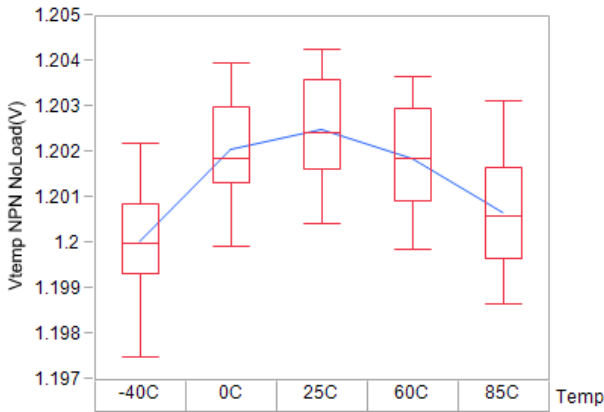

Figure 29.  $V_{TEMP}$  Voltage Accuracy (No Load)

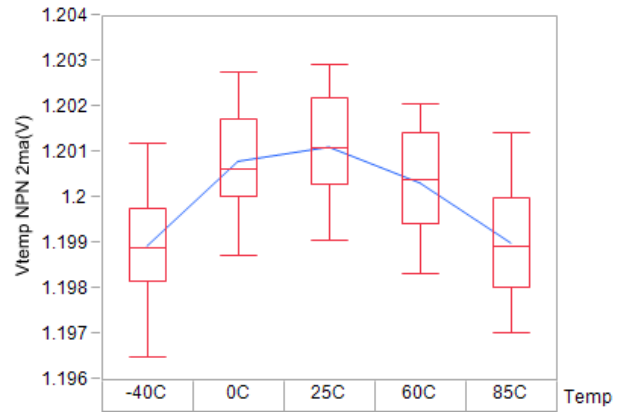

Figure 30.  $V_{TEMP}$  Voltage Accuracy (2mA Load)

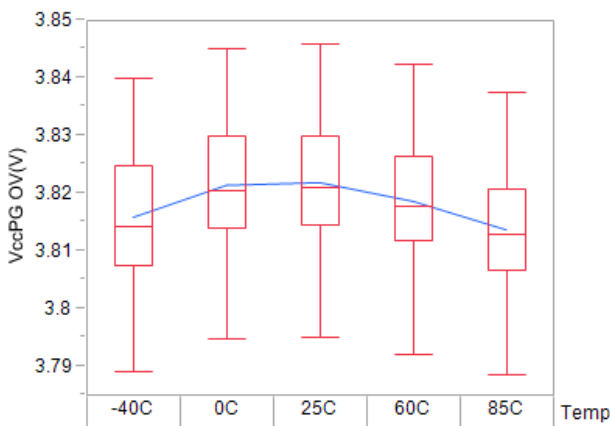

Figure 31. VCC PG OV Threshold

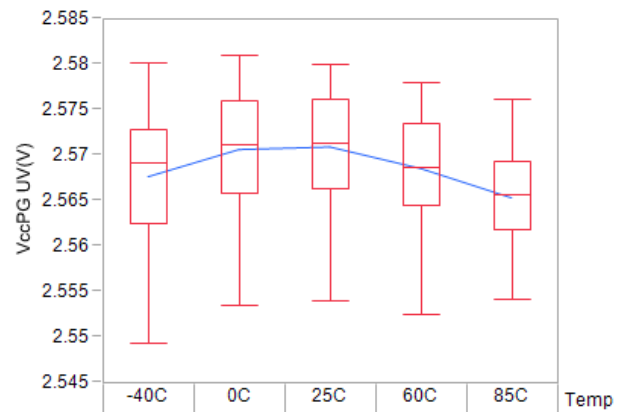

Figure 32. VCC PG UV Threshold

$T_A = +25^\circ\text{C}$ ,  $V_{BAT1} = V_{BAT2} = 48\text{V}$ ,  $(V_{C_n} - V_{C_{n-1}}) = 3\text{V}$ ,  $V_{CC} = V_{DD} = 3.3\text{V}$ , averages = 1,  $V_{SS} = \text{DGND} = 0\text{V}$ , unless otherwise specified. Cell balancing is off. (Continued)

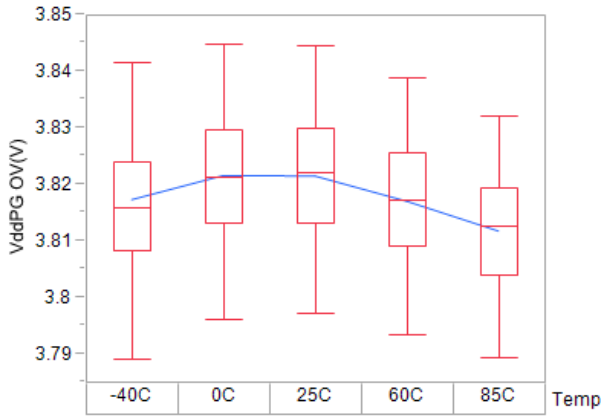

Figure 33. VDD PG OV Threshold

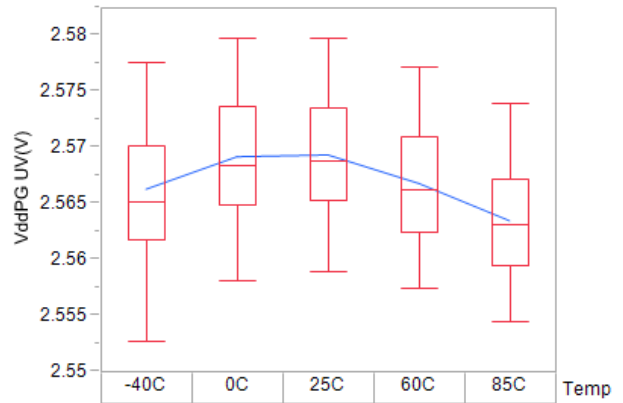

Figure 34. VDD PG UV Threshold

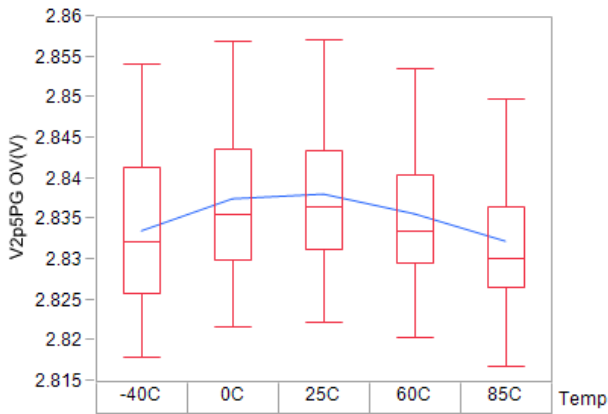

Figure 35. V2P5 PG OV Threshold

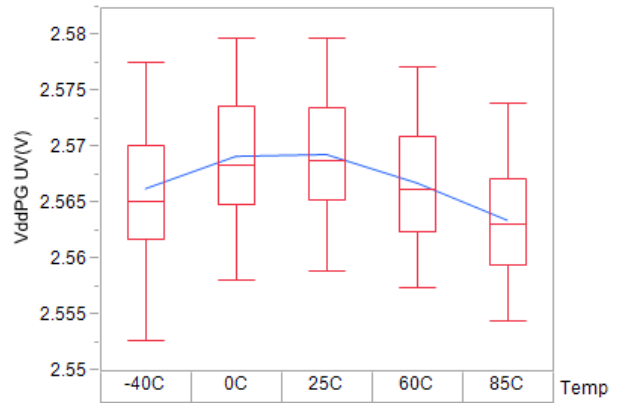

Figure 36. V2P5 PG UV Threshold

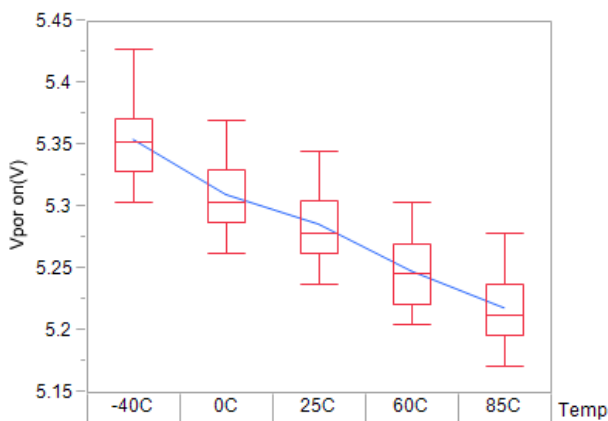

Figure 37. Power-On Reset ON Voltage (VBAT1)

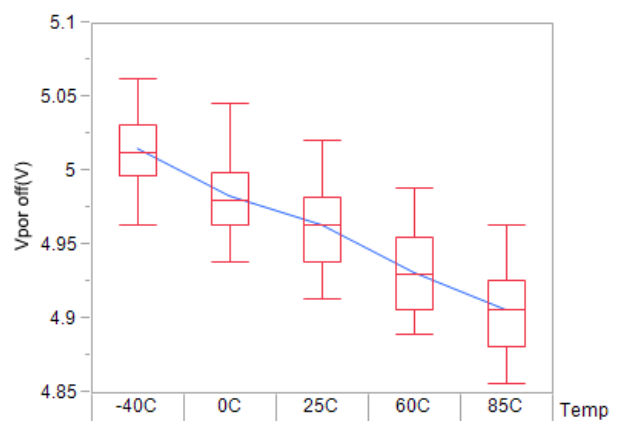

Figure 38. Power-On Reset OFF Voltage (VBAT1)

$T_A = +25^\circ\text{C}$ ,  $V_{BAT1} = V_{BAT2} = 48\text{V}$ ,  $(V_{Cn} - V_{Cn-1}) = 3\text{V}$ ,  $V_{CC} = V_{DD} = 3.3\text{V}$ , averages = 1,  $V_{SS} = \text{DGND} = 0\text{V}$ , unless otherwise specified. Cell balancing is off. **(Continued)**

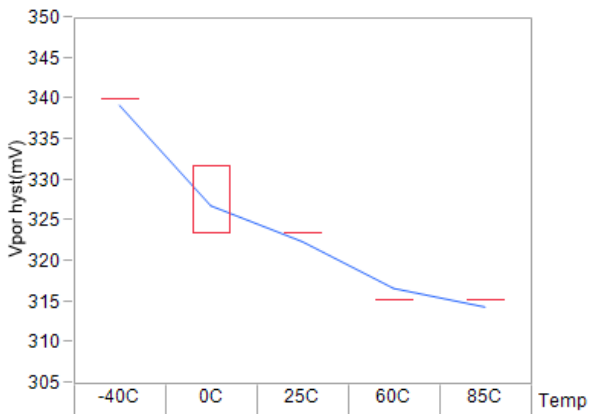

Figure 39. Power-On Reset Hysteresis

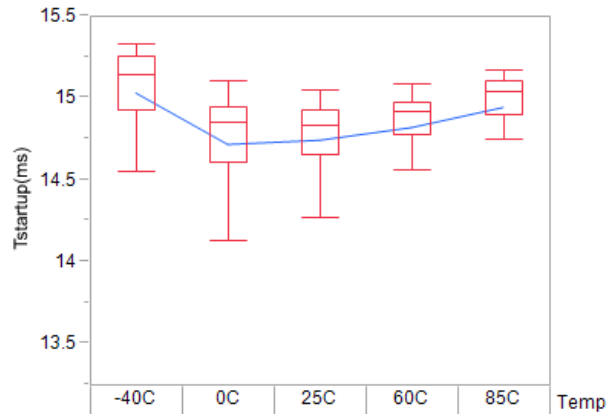

Figure 40. POR Startup Time To Measurement

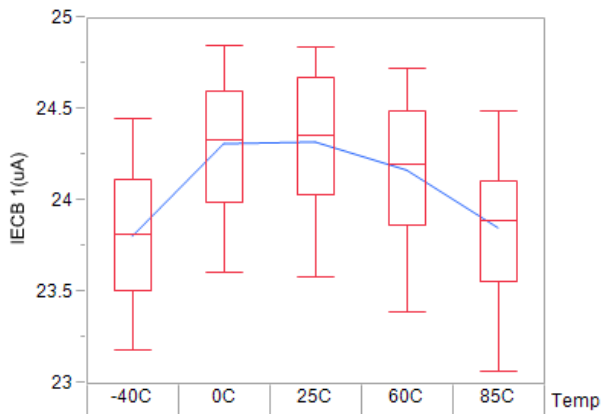

Figure 41. CB1 Pin Input Current (Active)

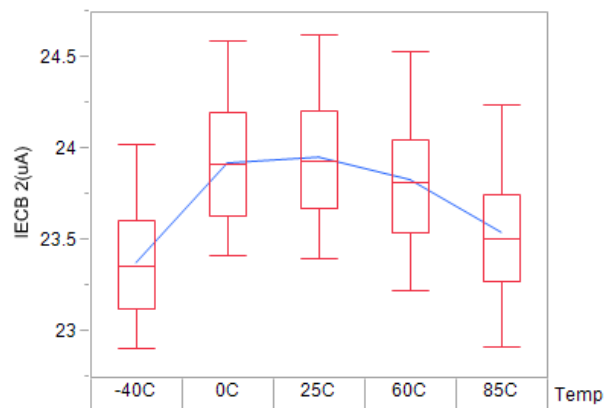

Figure 42. CB2 Pin Input Current (Active)

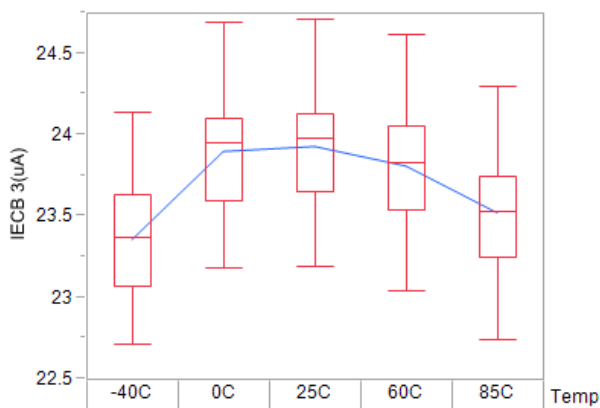

Figure 43. CB3 Pin Input Current (Active)

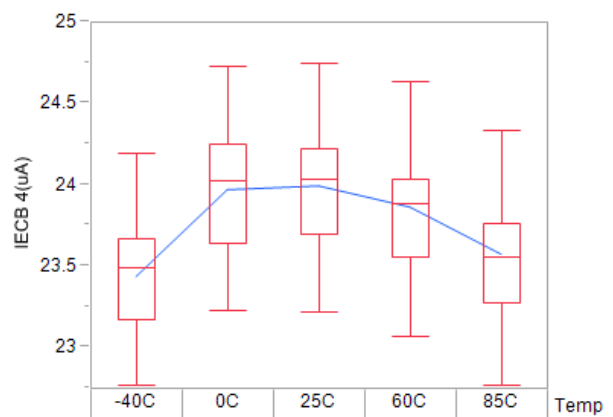

Figure 44. CB4 Pin Input Current (Active)

$T_A = +25^\circ\text{C}$ ,  $V_{BAT1} = V_{BAT2} = 48\text{V}$ ,  $(V_{Cn} - V_{Cn-1}) = 3\text{V}$ ,  $V_{CC} = V_{DD} = 3.3\text{V}$ , averages = 1,  $V_{SS} = \text{DGND} = 0\text{V}$ , unless otherwise specified. Cell balancing is off. (Continued)

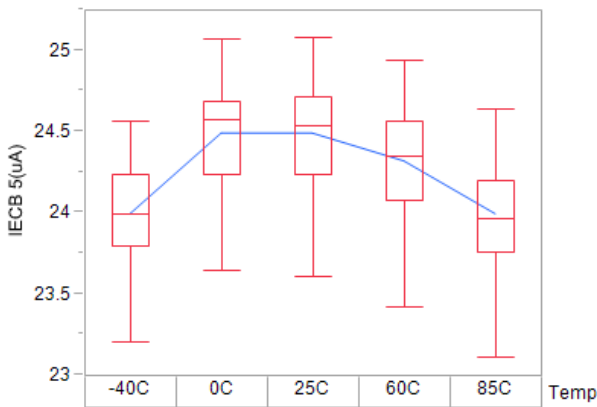

Figure 45. CB5 Pin Input Current (Active)

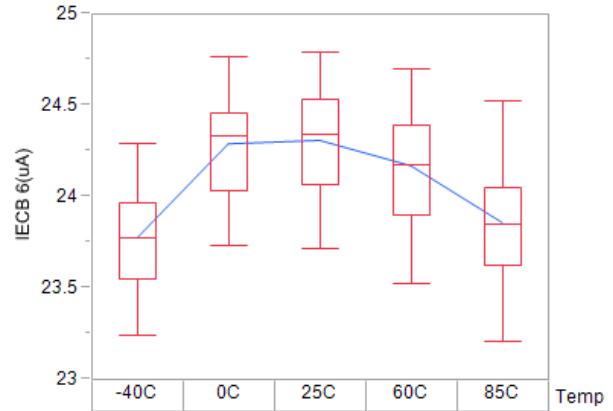

Figure 46. CB6 Pin Input Current (Active)

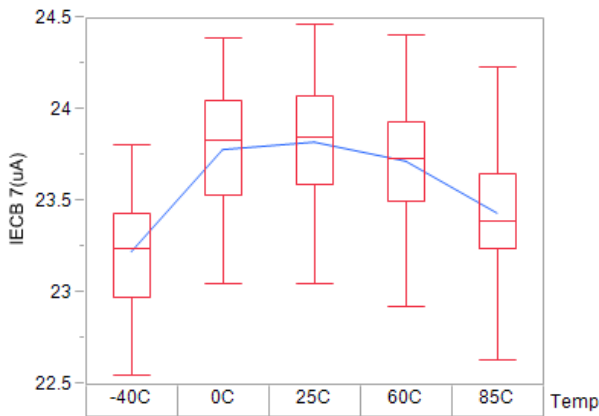

Figure 47. CB7 Pin Input Current (Active)

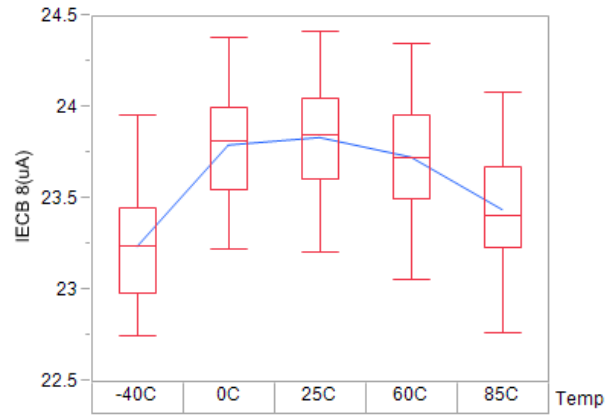

Figure 48. CB8 Pin Input Current (Active)

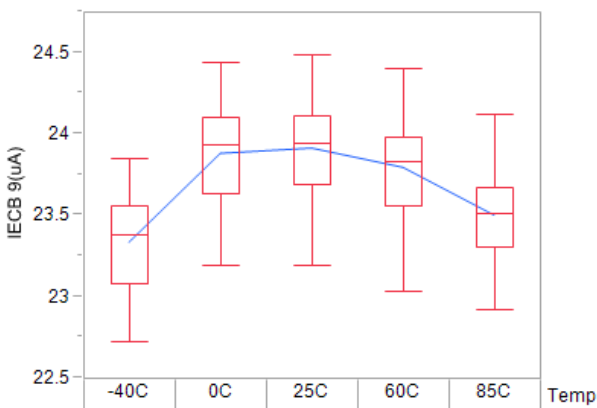

Figure 49. CB9 Pin Input Current (Active)

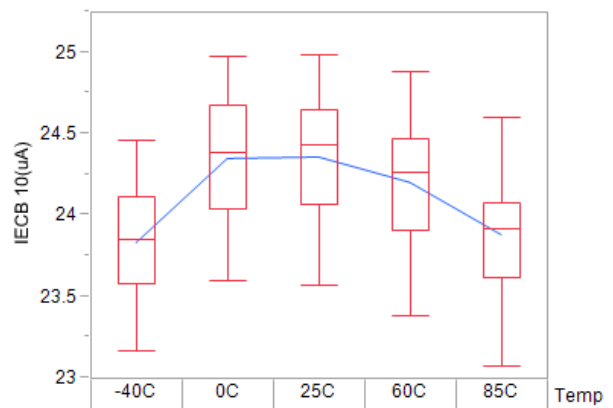

Figure 50. CB10 Pin Input Current (Active)

$T_A = +25^\circ\text{C}$ ,  $V_{BAT1} = V_{BAT2} = 48\text{V}$ ,  $(V_{Cn} - V_{Cn-1}) = 3\text{V}$ ,  $V_{CC} = V_{DD} = 3.3\text{V}$ , averages = 1,  $V_{SS} = \text{DGND} = 0\text{V}$ , unless otherwise specified. Cell balancing is off. **(Continued)**

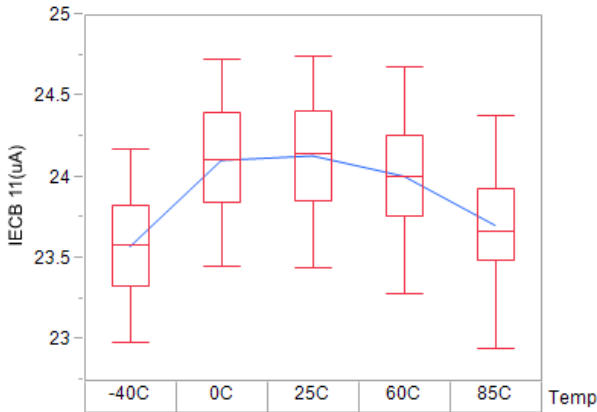

Figure 51. CB11 Pin Input Current (Active)

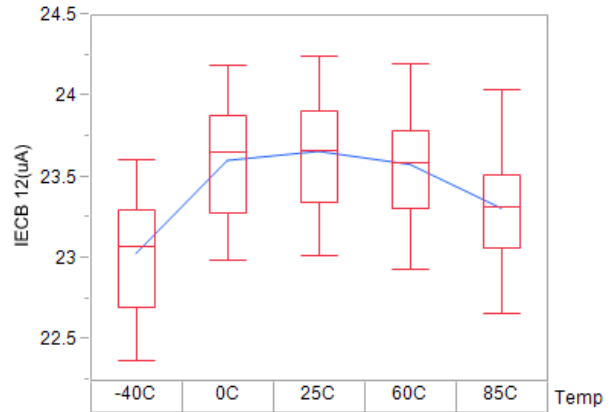

Figure 52. CB12 Pin Input Current (Active)

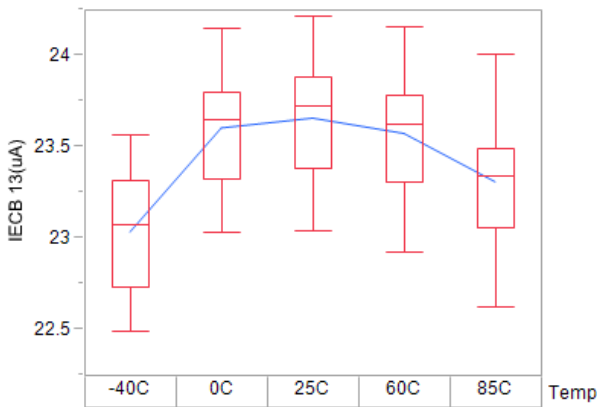

Figure 53. CB13 Pin Input Current (Active)

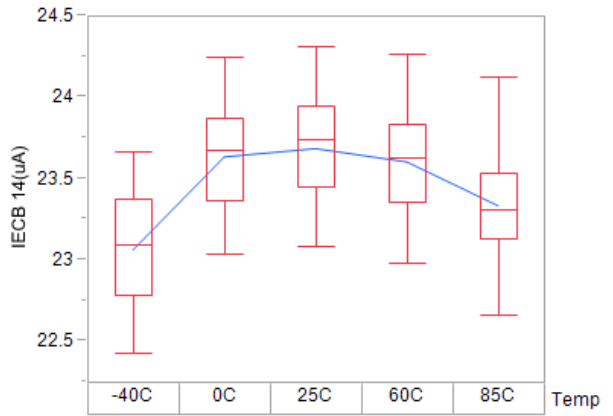

Figure 54. CB14 Pin Input Current (Active)

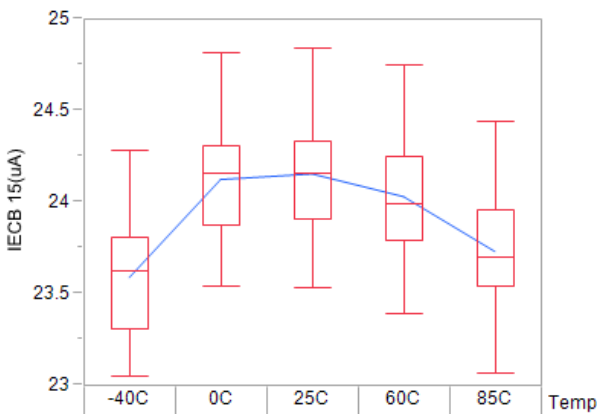

Figure 55. CB15 Pin Input Current (Active)

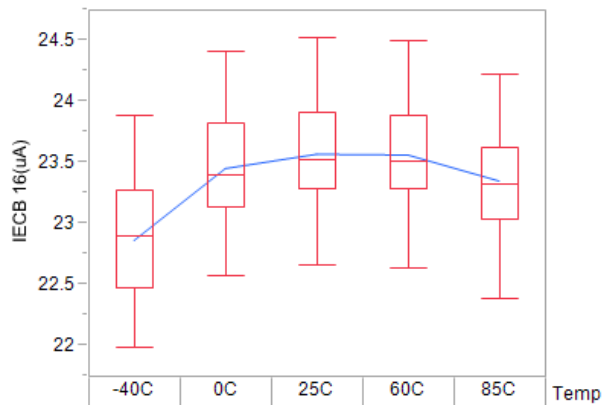

Figure 56. CB16 Pin Input Current (Active, CP On)

$T_A = +25^\circ\text{C}$ ,  $V_{BAT1} = V_{BAT2} = 48\text{V}$ ,  $(V_{Cn} - V_{Cn-1}) = 3\text{V}$ ,  $V_{CC} = V_{DD} = 3.3\text{V}$ , averages = 1,  $V_{SS} = \text{DGND} = 0\text{V}$ , unless otherwise specified. Cell balancing is off. **(Continued)**

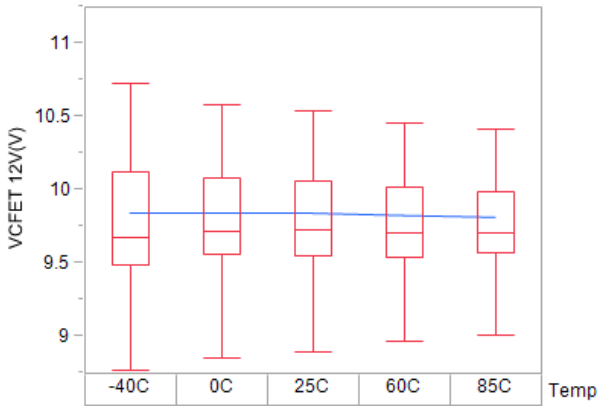

Figure 57. CFET Gate Drive Voltage at VBAT1 = 12V

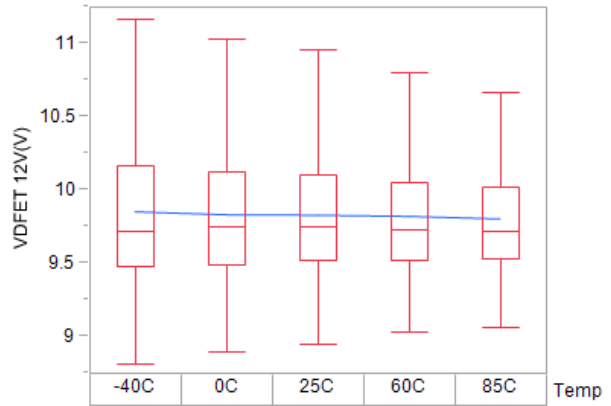

Figure 58. DFET Gate Drive Voltage at VBAT1 = 12V

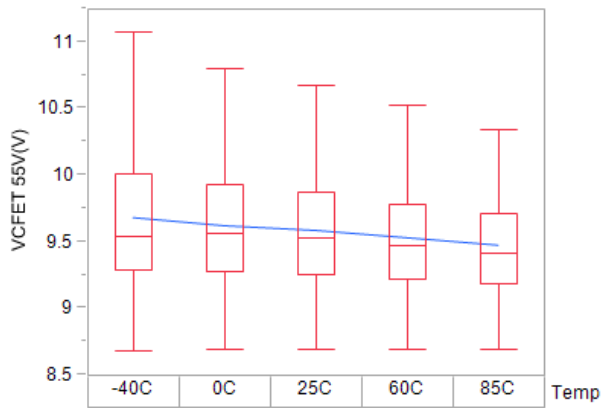

Figure 59. CFET Gate Drive Voltage at VBAT1 = 55V

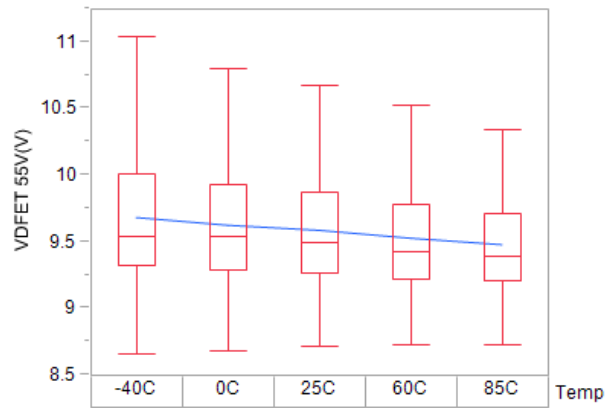

Figure 60. DFET Gate Drive Voltage at VBAT1 = 55V

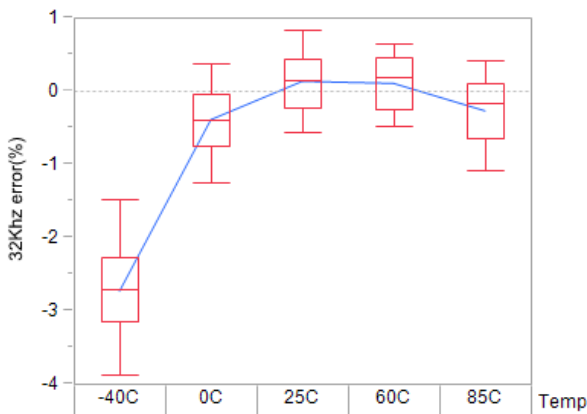

Figure 61. Internal 32kHz Oscillator Accuracy

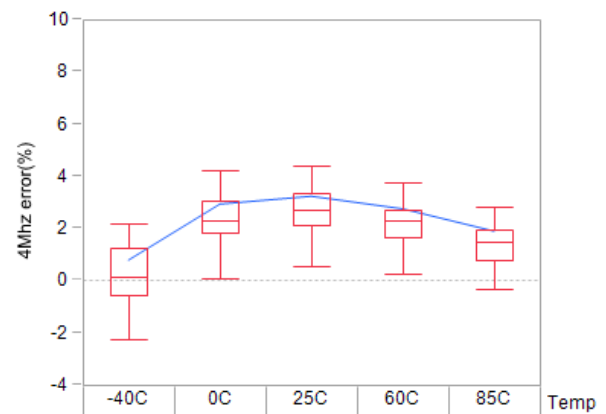

Figure 62. Internal 4MHz Oscillator Accuracy



$T_A = +25^{\circ}\text{C}$ ,  $V_{BAT1} = V_{BAT2} = 48\text{V}$ ,  $(V_{Cn} - V_{Cn-1}) = 3\text{V}$ ,  $V_{CC} = V_{DD} = 3.3\text{V}$ , averages = 1,  $V_{SS} = \text{DGND} = 0\text{V}$ , unless otherwise specified. Cell balancing is off. (Continued)

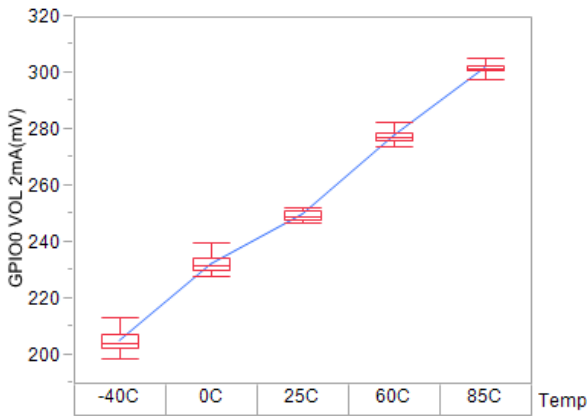

Figure 63. GPIO0 VOL at 2mA Load

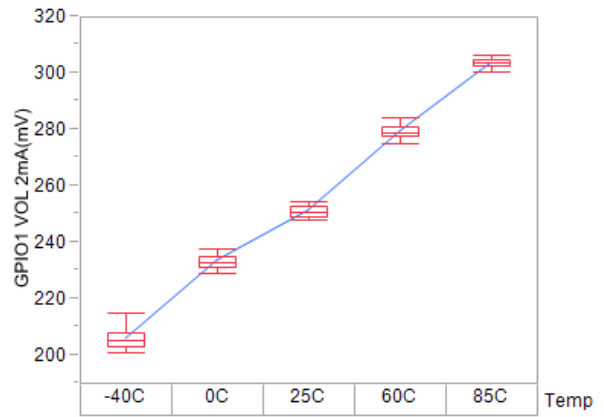

Figure 64. GPIO1 VOL at 2mA Load

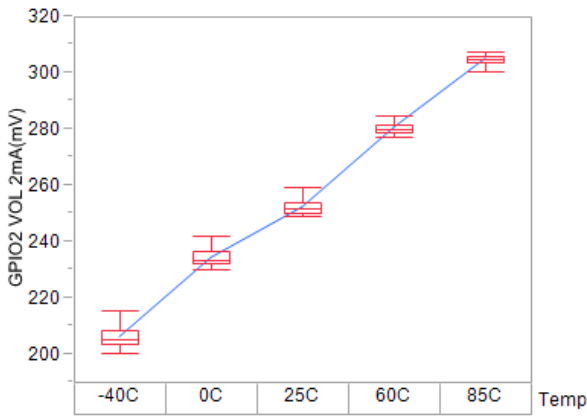

Figure 65. GPIO2 VOL at 2mA Load

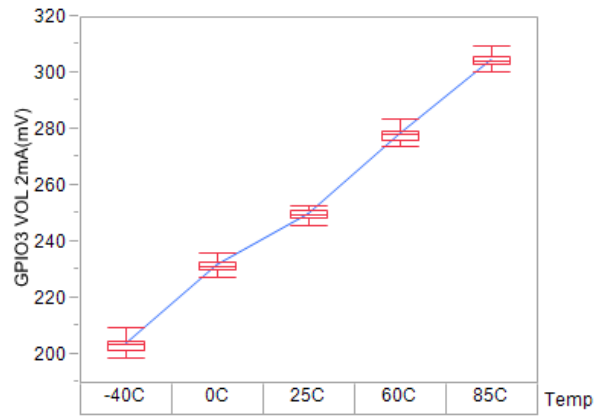

Figure 66. GPIO3 VOL at 2mA Load

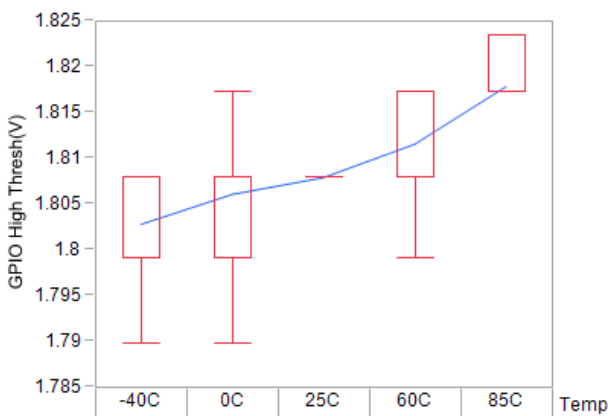

Figure 67. GPIO VIH

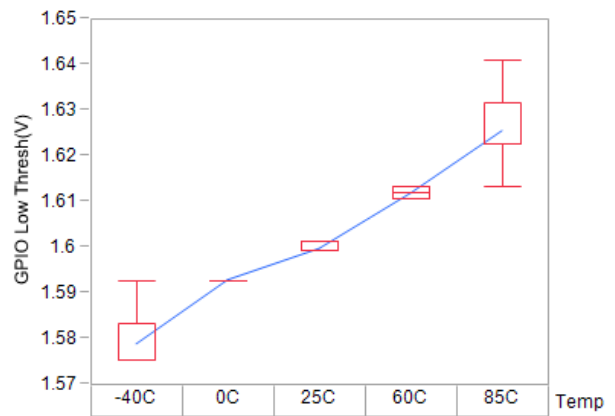

Figure 68. GPIO VIL

$T_A = +25^{\circ}\text{C}$ ,  $V_{BAT1} = V_{BAT2} = 48\text{V}$ ,  $(V_{C_n} - V_{C_{n-1}}) = 3\text{V}$ ,  $V_{CC} = V_{DD} = 3.3\text{V}$ , averages = 1,  $V_{SS} = \text{DGND} = 0\text{V}$ , unless otherwise specified. Cell balancing is off. **(Continued)**

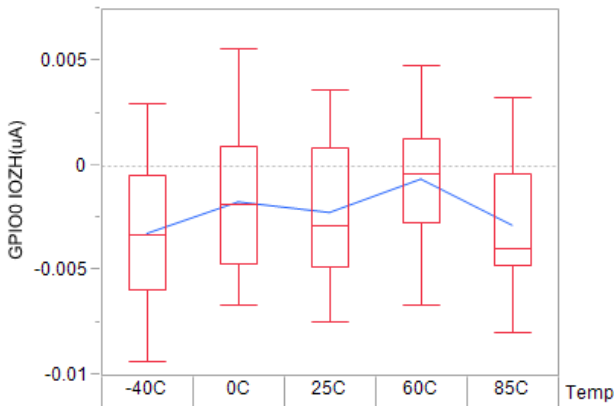

Figure 69. GPIO0 Leakage Current (3.3V)

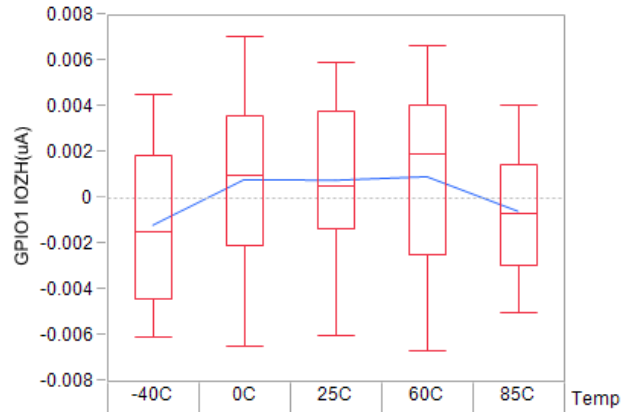

Figure 70. GPIO1 Leakage Current (3.3V)

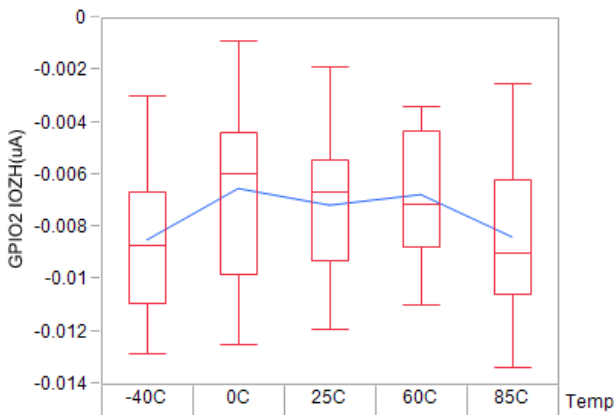

Figure 71. GPIO2 Leakage Current (3.3V)

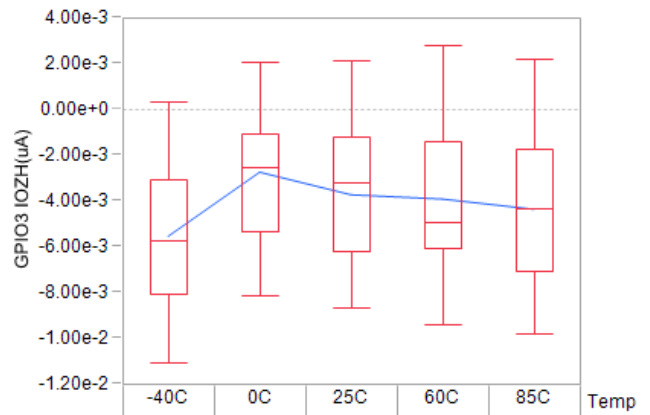

Figure 72. GPIO3 Leakage Current (3.3V)

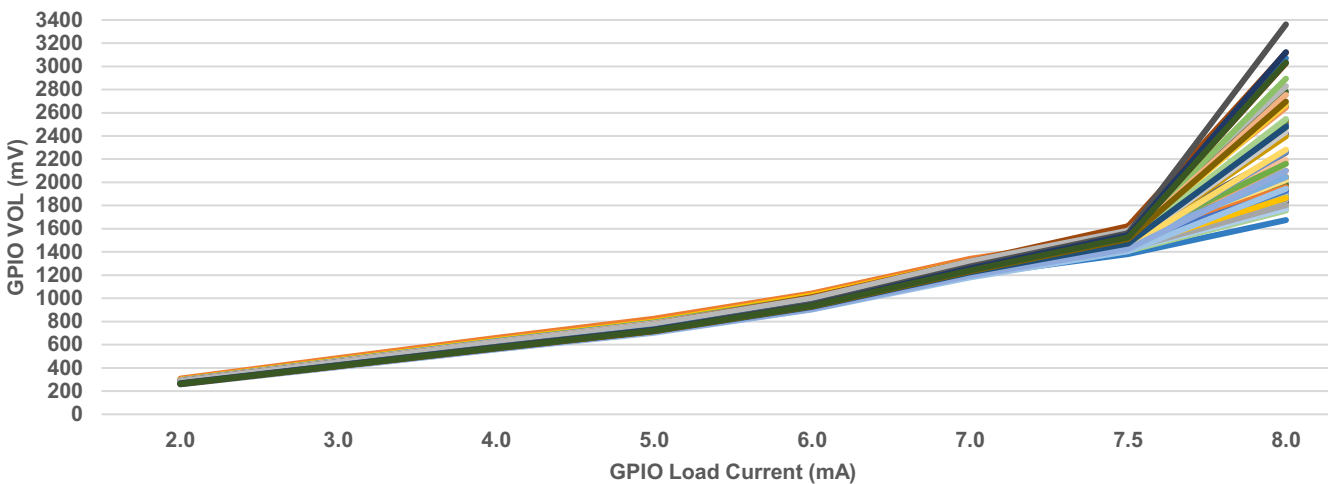

Figure 73. GPIO Sink Current vs Voltage

$T_A = +25^\circ\text{C}$ ,  $V_{BAT1} = V_{BAT2} = 48\text{V}$ ,  $(V_{C_n} - V_{C_{n-1}}) = 3\text{V}$ ,  $V_{CC} = V_{DD} = 3.3\text{V}$ , averages = 1,  $V_{SS} = \text{DGND} = 0\text{V}$ , unless otherwise specified. Cell balancing is off. **(Continued)**

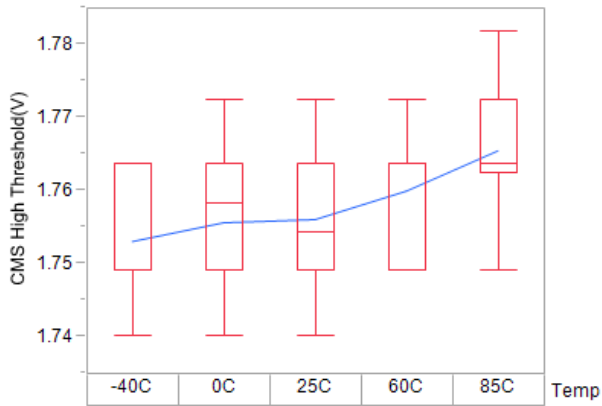

Figure 74. CMS Pins VIH

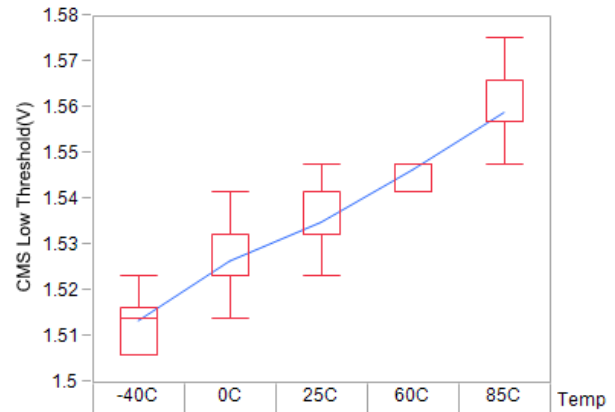

Figure 75. CMS Pins VIL

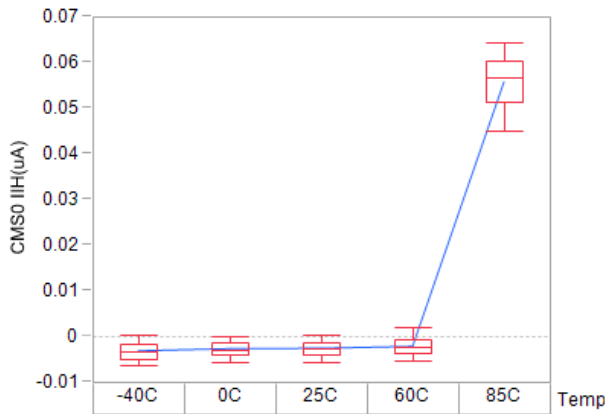

Figure 76. CMS0 Leakage Current (3.3V)

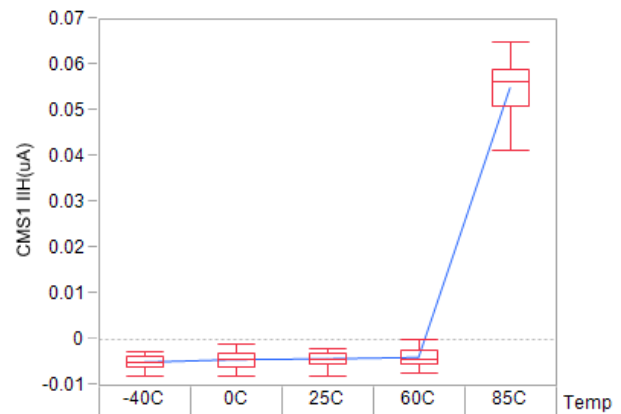

Figure 77. CMS1 Leakage Current (3.3V)

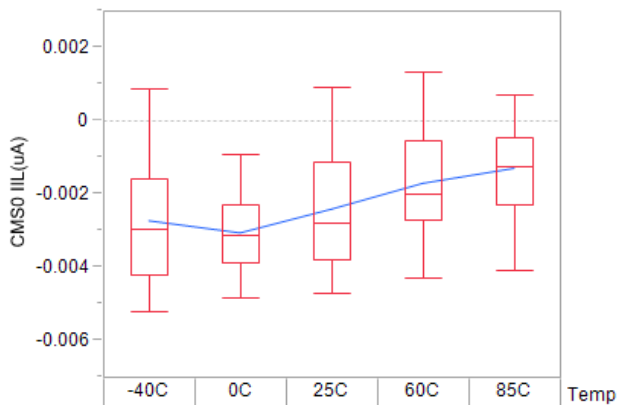

Figure 78. CMS0 Leakage Current (0V)

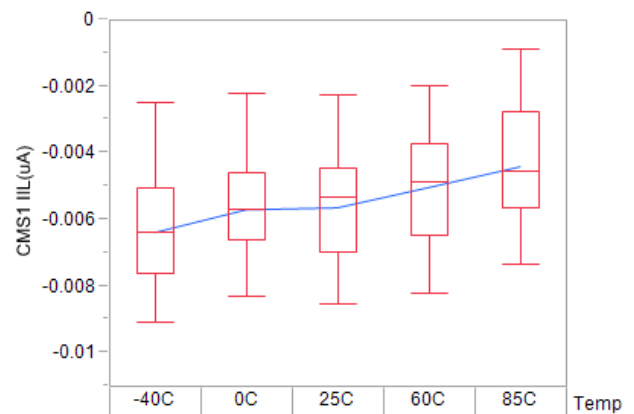

Figure 79. CMS1 Leakage Current (0V)

## 5. System Registers

Each system register contains eight bits and is accessed using a 7-bit address plus an 8th bit that indicates a read or a write. For details about reading and writing registers, see [“Communication Interface” on page 120](#) and the register descriptions.

All system registers are listed in [Table 3](#). Each register listing includes the address, register name, and a page number for more details, as well as a depiction of the contents with bit names, value at power up or after the chip is reset (POR value), and the type of register follow (Read or Read/Write). The ISL94216 is configured for specific applications by a microcontroller accessing these registers.

The ISL94216 has a 16-bit ADC for voltage measurements. The outputs of many parameter readings use two 8-bit values to represent the digitized result. Register addresses of some readings are shown as two register values delimited with a comma. For example, 0x52, 53 are register addresses for the  $I_{PACK}$  voltage. Register 0x52 contains the MSB and register 0x53 contains the LSB. The 8-bit threshold registers are compared to the upper 8-bits of the 16-bit measurements.

The ranges and step-sizes listed for threshold and measurement registers are the ideal values to be used for calculation purposes. Threshold settings that would require operation outside of the recommended operating conditions are not supported. The usable measurement range is also limited by the recommended operating conditions and by non-idealities of the measurement channel. Measurement results registers may or may not reach the maximum or minimum for input voltages within the ideal voltage range listed.

Within some control registers are bits called “Trigger bits” that execute automatic sequences when set to “1”. Triggered sequences are initiated by a 0 to 1 transition of a Trigger bit. See [“Trigger Bits” on page 119](#) for a detailed description of the use and limitations of Trigger bits.

Registers at addresses 0x83 through 0x89 contain “Mask bits”. Set Mask bits to “1” (default) to prevent the fault related to that bit from asserting the  $\overline{ALRT}$  pin low. A Mask bit must be set to “0” to allow the assertion of the  $\overline{ALRT}$  pin LOW when the fault related to that bit occurs.

Reserved bits (RSV) should be ignored when reading registers and set to “0” when writing to them.

**Table 3. System Register List**

Register Address (Hex)	Register Name	Page	Bit Function								Power On Reset Value (Hex)	Type
			7 (MSB)	6	5	4	3	2	1	0 (LSB)		
<b>Device Details</b>												
00	System Information	<a href="#">39</a>	Part ID				Product Revision			RSV	F0	R
<b>Global IC Controls</b>												
01	Global Operation	<a href="#">39</a>	SFT RST	RESET 2 IDLE	RCAL VOS Trigger	RCAL LPM EN	RCAL Scan	BUSY	SYS Scan SEL	SYS Scan Trigger	00	R/W
<b>V<sub>CELL</sub> and I<sub>PACK</sub> Controls</b>												
02	V <sub>CELL</sub> Operation	<a href="#">42</a>	V <sub>CELL</sub> EN	DCHR WOV	CHRW UV	V <sub>CELL</sub> Averages			Clear Faults and Status	V <sub>CELL</sub> Trigger	80	R/W
03	I <sub>PACK</sub> Operation	<a href="#">43</a>	I <sub>PACK</sub> EN	OW Update		I <sub>PACK</sub> Averages			I <sub>DIR</sub> Delay	I <sub>PACK</sub> Trigger	80	R/W
04	Cell Select	<a href="#">44</a>	Cell 16	Cell 15	Cell 14	Cell 13	Cell 12	Cell 11	Cell 10	Cell 9	FF	R/W
05			Cell 8	Cell 7	Cell 6	Cell 5	Cell 4	Cell 3	Cell 2	Cell 1	FF	R/W
30, 31--4E, 4F	V <sub>CELL</sub> Voltage (16, 2-Byte read, Cells 1-16)	<a href="#">45</a>	Step: 73.55μV; Range: 36.77μV to 4.820V								00 00	R

**Table 3. System Register List (Continued)**

Register Address (Hex)	Register Name	Page	Bit Function								Power On Reset Value (Hex)	Type
			7 (MSB)	6	5	4	3	2	1	0 (LSB)		
50, 51	V <sub>CELL</sub> Max Delta Voltage	<a href="#">45</a>	Two-Byte Read; Step 73.55μV; Range 36.77μV to 4.820V								00 00	R
52, 53	I <sub>PACK</sub> Voltage	<a href="#">46</a>	Two-Byte Read; Step 10.51μV; Range ±344.28mV								00 00	R
54 to 57	I <sub>PACK</sub> Timer (4-byte read)	<a href="#">46</a>	Step 15ms; Range: 0 to 2.043 years								00 00 00 00	R
<b>V<sub>CELL</sub> Detectors</b>												
06	V <sub>CELL</sub> OV Threshold	<a href="#">46</a>	Step 18.83mV; Range 18.79mV to 4.820V								FF	R/W
07	V <sub>CELL</sub> UV Threshold	<a href="#">46</a>	Step 18.83mV; Range 36.77μV to 4.801V								00	R/W
08	V <sub>CELL</sub> Max Delta Threshold	<a href="#">47</a>	Step 18.83mV; Range 18.79mV to 4.820V								FF	R/W
09	Fault Delay	<a href="#">48</a>	AUX Pull-up	ΔV <sub>CELL</sub> Fault Delay	Other Fault Delay	ETAUX Fault Delay	V <sub>CELL</sub> Fault Delay				00	R/W
<b>I<sub>PACK</sub> Detectors</b>												
0A	Discharge Short-Circuit (DSC) Current Threshold	<a href="#">49</a>	RSV	RSV	RSV	RSV	Step: -40.167mV; Range: -642.67mV to -80.3mV				0F	R/W
0B	Discharge Overcurrent (DOC) Threshold	<a href="#">50</a>	Step -1.345mV; Range -342.95mV to -5.25μV								FF	R/W
0C	DSC Delay	<a href="#">50</a>	RSV	Step 31.25μs; Range: 0 to 4000μs							00	R/W
0D	OC Delay	<a href="#">51</a>	DOC Delay: Range 1 to 16 Scans				COC Delay: Range 1 to 16 Scans				00	R/W
0E	Load/Charge Operation	<a href="#">52</a>	CFD	ELD		ELR	CPWR	FCDC	LDLP	RSV	B4	R/W
0F	Charge Overcurrent (COC) Threshold	<a href="#">55</a>	Step 1.345mV; Range: 5.25μV to 342.95mV								FF	R/W
<b>External Temperature/Auxiliary Port (ETAUX) Controls</b>												
11	ETAUX Operation	<a href="#">56</a>	ETAUX EN		RSV	ETAUX Average			RSV	ETAUX Trigger	C0	R/W
12	GPIO and ALRT Operation	<a href="#">57</a>	ALRT Assert	ALRT Pulse EN	GPIO Config		GPIO STATUS				1F	R/W
58,59 5A,5B	ETAUX 0,1 Voltage (Four 8-bit reads)	<a href="#">59</a>	Step: 24.51μV; Range: 12.26μV to 1.6067V								00 00	R
<b>External Temperature/Auxiliary Port (ETAUX) Detectors</b>												
13	DUT0 Limit	<a href="#">59</a>	Step: 6.276mV; Range: 6.264mV to 1.6067V								FF	R/W
14	DOT0 Limit	<a href="#">59</a>	Step: 6.276mV; Range: 6.264mV to 1.6067V								00	R/W
15	CUT0 Limit	<a href="#">59</a>	Step: 6.276mV; Range: 6.264mV to 1.6067V								FF	R/W
16	COT0 Limit	<a href="#">59</a>	Step: 6.276mV; Range: 6.264mV to 1.6067V								00	R/W
17	DUT1 Limit	<a href="#">59</a>	Step: 6.276mV; Range: 6.264mV to 1.6067V								FF	R/W
18	DOT1 Limit	<a href="#">59</a>	Step: 6.276mV; Range: 6.264mV to 1.6067V								00	R/W
19	CUT1 Limit	<a href="#">59</a>	Step: 6.276mV; Range: 6.264mV to 1.6067V								FF	R/W
1A	COT1 Limit	<a href="#">59</a>	Step: 6.276mV; Range: 6.264mV to 1.6067V								00	R/W
<b>Internal Temperature</b>												
22	IOTW Threshold	<a href="#">61</a>	Internal Temp Warning: Step 0.839°C; Range: -63.7°C to +151.11°C								51	R/W

**Table 3. System Register List (Continued)**

Register Address (Hex)	Register Name	Page	Bit Function								Power On Reset Value (Hex)	Type
			7 (MSB)	6	5	4	3	2	1	0 (LSB)		
23	IOTF Threshold	<a href="#">61</a>	Internal Temp Fault: Step 0.839°C; Range: -63.7°C to +151.11°C								45	R/W
5E	Internal Temperature	<a href="#">62</a>	Step 0.839°C; Range: -63.7°C to +151.11°C								00	R
<b>Voltage Regulator</b>												
1B	V <sub>REG</sub> Operation	<a href="#">63</a>	Communications Timeout		UPDATE Other		LD DELAY		LP REG	VREG Trigger	F0	R/W
1C	V <sub>VCC</sub> Minimum Threshold	<a href="#">64</a>	Step 25.104mV; Range: 12.55mV to 6.414V								00	R/W
1D	I <sub>REGOC1</sub> Threshold	<a href="#">65</a>	(SCAN and IDLE modes); Step: 1.345mV; Range: 1.34mV to 344.28mV								FF	R/W
1E	I <sub>REGOC2</sub> Threshold	<a href="#">65</a>	(LOW POWER Mode); Step: 1.345mV; Range: 1.34mV to 344.28mV								FF	R/W
5F	V <sub>TEMP</sub> Voltage	<a href="#">65</a>	Step 3.138mV; Range: 0.80491V to 1.60511V								00	R
60	V <sub>CC</sub> Voltage	<a href="#">65</a>	Step 25.104mV; Range: 12.55mV to 6.414V								00	R
61, 62	I <sub>REG</sub> Voltage (Two 8-Bit Reads)	<a href="#">66</a>	Step 10.51μV; Range 5.25μV to 344.28mV								00 00	R
<b>V<sub>BAT1</sub> Controls</b>												
1F	V <sub>BAT1</sub> Operation	<a href="#">66</a>	V <sub>BAT1</sub> EN	I <sub>TEMP</sub> EN	I <sub>TEMP</sub> Trigger	Other Averages			Comm TO EN	V <sub>BAT1</sub> Trigger	C2	R/W
20	OV <sub>BAT1</sub> Threshold	<a href="#">68</a>	Step: 301.25mV; Range: 300.66mV to 77.12V								FF	R/W
21	UV <sub>BAT1</sub> Threshold	<a href="#">69</a>	Step: 301.25mV; Range: 300.66mV to 77.12V								00	R/W
5C, 5D	V <sub>BAT1</sub> Voltage	<a href="#">68</a>	(Two 8-bit reads) Step: 1.177mV; Range: 0.588mV to 77.12V								00 00	R
<b>Power FET Controls and Open-Wire</b>												
24	Power FET Operation	<a href="#">70</a>	CPMP EN	OW EN	OW Trigger	CELL CON	V <sub>BAT1</sub> CON	ETAUX CON	DFET EN	CFET EN	5C	R/W
<b>CELL Balancing Controls</b>												
25	CB Operation	<a href="#">73</a>	CB EN	AUTO CB EN	CB Config	CB Trigger	IEOC EN	CB Mask	CB EOC	CB CHRGR	01	R/W
26	CB Cell State (2 8-bit reads/writes)	<a href="#">75</a>	Cell 16	Cell 15	Cell 14	Cell 13	Cell 12	Cell 11	Cell 10	Cell 9	00	R/W
27			Cell 8	Cell 7	Cell 6	Cell 5	Cell 4	Cell 3	Cell 2	Cell 1	00	R/W
28	Cell Balance On Time	<a href="#">78</a>	Step: 8 Range 0 to 1016							Unit	00	R/W
29	Cell Balance Off Time	<a href="#">78</a>	Step: 8 Range 0 to 1016							Unit	00	R/W
<b>CELL Balancing Detectors</b>												
2A	CB Min Delta Threshold	<a href="#">76</a>	Step 4.707mV; Range: 4.67mV to 1.20497V								00	R/W
2B	CBMAX Threshold	<a href="#">76</a>	Step 18.828mV; Range: 18.79V to 4.820V								FF	R/W
2C	CBMIN Threshold	<a href="#">77</a>	Step 18.828mV; Range: 36.77μV to 4.801257V								00	R/W
2D	VEOC Threshold	<a href="#">77</a>	Step 18.828mV; Range: 18.79V to 4.820V								FF	R/W
10	EOC Current Threshold (IEOC)	<a href="#">78</a>	Step 1.345mV; Range: 5.25μV to 342.95mV								00	R/W
<b>System Faults and Indicators</b>												
63	Priority Faults	<a href="#">79</a>	VCCF	OWF	IOTF	COCF	DOCF	DSCF	UVF	OVF	00	R/W
64	ETAUX Faults	<a href="#">81</a>	COT1	CUT1	DOT1	DUT1	COT0	CUT0	DOT0	DUT0	00	R/W

**Table 3. System Register List (Continued)**

Register Address (Hex)	Register Name	Page	Bit Function								Power On Reset Value (Hex)	Type
			7 (MSB)	6	5	4	3	2	1	0 (LSB)		
65	Other Faults	<a href="#">83</a>	VBOVF	VBUVF	CPMP NRDY	OW xT1	OW xT0	OW V <sub>BAT1</sub>	OW VSS	CRCF	20	R/W
66	CB Status	<a href="#">85</a>	BAT FULL	IOTW	IEOC	VEOC	DVCF	2HI2CB	2LO2CB	NEED CB	00	R/W
67	Status	<a href="#">87</a>	DCHRG I	CHRG I	CH PRESI	LD PRESI	OTHER FAULTS	IREG1	IREG2	VTMPF	00	R/W
68	Open-Wire Status (Two Bytes)	<a href="#">88</a>	OW16	OW15	OW14	OW13	OW12	OW11	OW10	OW9	00	R/W
69			OW8	OW7	OW6	OW5	OW4	OW3	OW2	OW1	00	R/W
83	Priority Faults Mask	<a href="#">81</a>	VCCF MASK	OWF MASK	IOTF MASK	COCF MASK	DOCF MASK	DSCF MASK	UVF MASK	OVF MASK	FF	R/W
84	ETAUX Faults Mask	<a href="#">83</a>	COT1 MASK	CUT1 MASK	DOT1 MASK	DUT1 MASK	COT0 MASK	CUT0 MASK	DOT0 MASK	DUT0 MASK	FF	R/W
85	Other Faults Mask	<a href="#">85</a>	VBOVF MASK	VBUVF MASK	CPMP NRDY MASK	RSV	RSV	RSV	CRCF MASK	BUSY MASK	FF	R/W
86	CB Status Mask	<a href="#">86</a>	BAT FULL MASK	IOTW MASK	IEOC MASK	VEOC MASK	DVCF MASK	2HI2CB MASK	2LO2CB MASK	NEED CB MASK	FF	R/W
87	Status Mask	<a href="#">88</a>	DCHRG I MASK	CHRG I MASK	CH PRESI MASK	LD PRESI MASK	OTHER FAULTS MASK	IREG1 MASK	IREG2 MASK	VTMPF MASK	FF	R/W
88	Open-Wire Mask (Two Bytes)	<a href="#">88</a>	OWM Cell16	OWM Cell15	OWM Cell14	OWM Cell13	OWM Cell12	OWM Cell11	OWM Cell10	OWM Cell9	FF	R/W
89			OWM Cell8	OWM Cell7	OWM Cell6	OWM Cell5	OWM Cell4	OWM Cell3	OWM Cell2	OWM Cell1	FF	R/W
<b>System Operation</b>												
2E	Scan Operation	<a href="#">101</a>	System Mode		LOW POWER Timer			Scan Delay			1B	R/W

## 5.1 IC Device Details

### 5.1.1 0x00 Product ID Register (R)

The 1-byte Product Identification register contains information about the die and is read only.

**Table 4. 0x00 Product ID Register**

Bits	D[7:4]	D[3:1]	D[0]
Bit Name	Part ID	Revision	RSV
Default	1111	XXX	X

#### 5.1.1.1 0x00.7:4 Part ID

The bit value of the Part ID represents the last two digits of the part ID minus one.

#### 5.1.1.2 0x00.3:1 Product Revision

The product revision is indicated by the value of this register.

## 5.2 Global IC Controls

### 5.2.1 0x01 Global Operation

The 1-byte Global Operation register includes controls and status of the overall state of the ISL94216.

**Table 5. 0x01 Operation Register**

Bits	D[7]	D[6]	D[5]	D[4]	D[3]	D[2]	D[1]	D[0]
Bit Name	SFT RST	RST2IDLE	RCAL V <sub>OS</sub> Trigger	RCAL LPM	RCAL Scan	BUSY	Scan Sel	System Trigger
Default	0	0	0	0	0	0	0	0

### 5.2.1.1 0x01.7 Soft Reset

Setting the Soft Reset bit of the Operation register to “1” resets all register values back to factory defaults, including data registers. All counters are set to “0”, all timers and faults are cleared, and the System mode is set to IDLE. A low voltage offset calibration is performed, the power and cell balancing FETs are turned off, and the state machines are reset. This bit is cleared on completion.

### 5.2.1.2 0x01.6 Reset to IDLE

When set to “1”, the Reset to IDLE bit of the Operation register stops all state machines and moves the chip state to IDLE mode upon receiving a stop bit. This command sets all counters to “0” and clears all timers and faults. The power and cell balancing FETs are turned off. The state machines are reset. All other register settings are not affected by this command and remain unchanged. This bit is cleared on completion.

### 5.2.1.3 0x01.5 Recalibrate V<sub>OS</sub> Trigger

A “0” to “1” transition of this bit in IDLE mode initiates a low voltage offset recalibration. Low voltage offset affects the V<sub>BAT1</sub>, V<sub>VCC</sub>, V<sub>TEMP</sub>, IT, xT0, and xT1 measurements. This bit is cleared on completion.

This trigger bit is ignored in SHIP and LOW POWER Modes and can only trigger sequences in IDLE or SCAN mode.

### 5.2.1.4 0x01.4 Recalibrate in LOW POWER Mode

Setting the Recalibrate in LOW POWER mode bit of the Operation register to “1” starts a low voltage offset recalibration for every measurement pass while in LOW POWER mode.

### 5.2.1.5 0x01.3 Recalibrate Scan

Setting the Recalibrate Scan bit of the Operation register to “1” initiates a low voltage offset recalibration before performing another System Scan. This bit has significance only in SCAN mode and must be set before starting continuous Scan.

### 5.2.1.6 0x01.2 Busy

A value of “1” for the Busy bit indicates that ISL94216 is busy either performing measurements or internal housekeeping. The Busy bit is read only and has a masking bit that connects the Busy bit status (inverted) to the ALRT pin. A Busy bit of “1” sets ALRT low. See [“0x85 Other Fault Mask” on page 85](#) for more information about the masking bit. **Note:** Do not read measurement result registers when the ISL94216 is busy making measurements to avoid obtaining stale or mixed results. The ISL94216 saves each measurement result as it is obtained, reading data registers while “Busy” can produce a mix of previous and present scan results.

### 5.2.1.7 0x01.1 Scan Select

The Scan Select bit chooses the type of System Scan that is performed when a System Trigger is initiated and the device is in SCAN mode.

If continuous System Scan (Default of “0”) is chosen, the device periodically measures system parameters as described in [“System Scan Sequence” on page 105](#). This selection reports a fault when the failure has exceeded the parameters fault delay setting. All fault counters are cleared at the beginning of a continuous scan, and no trace is left from previous System Scans. If a fault is detected, the power FETs turn off only if the fault output is “connected” to the FET driver (see [“0x24 Power FET Operation” on page 70](#)). A fault forces continuous scan to abort regardless of the connect bit settings and the MCU is expected to react.



If one instance of the System Scan is chosen (setting of “1”), the device measures system parameters as described in [“System Scan Sequence” on page 105](#). This System Scan also performs an open-wire check if [“0x24.6 OW EN” on page 71](#) is set to “1”. One cycle of cell balancing is executed if appropriate per settings. Measurements are made if the function(s) are enabled. Any faults are reported after the single System Scan completes.

If changes to continuous scan are necessary, set Scan Select bit to “1” and wait for the Busy bit to clear indicating the Scan has completed. Make the necessary changes and set Scan Select bit to “0” and the System Trigger bit (0x01.0) to “1” to restart continuous Scan.

### 5.2.1.8 0x01.0 System Trigger

A “0” to “1” transition of this bit in SCAN mode initiates a System Scan ([Figure 106 on page 105](#)). The type of System Scan is determined by the Scan Select bit setting. When the System Trigger bit has been received, the Busy bit (see [page 40](#)) transitions from a “0” to a “1”, and the System Trigger bit returns to “0”. The Busy bit remains high until the Scan Delay timer has started ([“0x2E.2:0 Scan Delay” on page 101](#)), and returns to “0”. If the System Trigger bit is set during an active scan, it is ignored and remains set until manually cleared.

If the Scan Select bit is set for continuous scan and there is an active fault, a System Scan is not initiated. The System Trigger bit does not automatically transition to a low. The fault must be cleared and the trigger bit set to a low before System Trigger is operational again. See [“Trigger Bits” on page 119](#) for detailed information.

The System Trigger bit is ignored when the System mode bits are SHIP, LOW POWER, or IDLE. It is executed only when the System mode bits are set to SCAN mode.

## 5.3 $V_{CELL}$ and $I_{PACK}$ Measurement

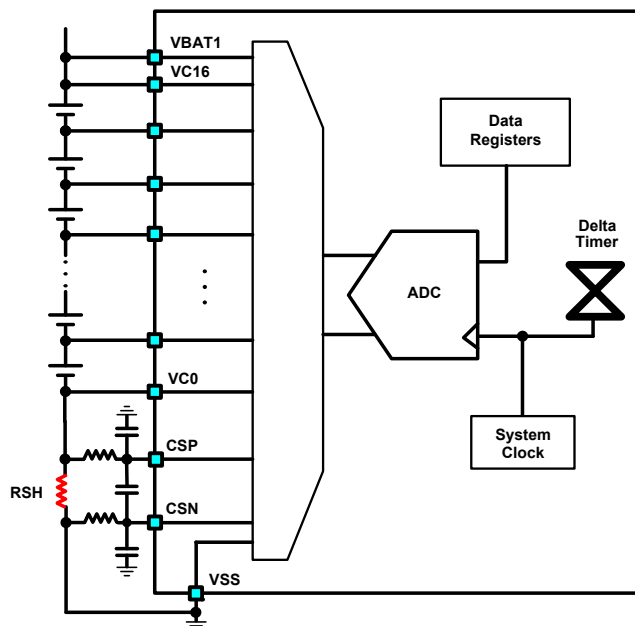

Figure 80. Voltage Measurement Block Diagram

A level shifter/multiplexer and 16-bit ADC within the ISL94216 enable measurement of BMS parameters ([Figure 80](#)). The results of these measurements are compared to user-selected detection thresholds.

An analog comparator checks for short-circuit conditions. Digital comparators are used for overcurrent and undercurrent, and overvoltage and undervoltage detection. For cell voltages, the detection thresholds are set by the user to prevent overcharge or discharge of individual cells based on chemistry and/or other considerations.

The ISL94216 measures the pack current sense resistor (RSH) voltage before cell voltage measurements. A delta timer tracks elapsed time between current sense measurements.

### 5.3.1 0x02 V<sub>CELL</sub> Operation

The V<sub>CELL</sub> Operation register controls data acquisition and part of the OV/UV fault behavior for V<sub>CELL</sub> measurements. This register also contains the bit that clears latched fault and status bits.

**Table 6. 0x02 V<sub>CELL</sub> Operation Register**

Bits	D[7]	D[6]	D[5]	D[4:2]	D[1]	D[0]
Bit Name	V <sub>CELL</sub> EN	DCHRWOV	CHRWUV	V <sub>CELL</sub> Averages	Clear Faults/Status	V <sub>CELL</sub> Trigger
Default	1	0	0	0 00	0	0

#### 5.3.1.1 0x02.7 V<sub>CELL</sub> EN

Set the V<sub>CELL</sub> Enable bit to “1” (default) to enable V<sub>CELL</sub> measurements within System Scans. The cells to be included in a System Scan are determined by the setting of registers [“0x04 - 0x05 Cell Select” on page 44](#). Set this bit to “0” to disable V<sub>CELL</sub> measurement during System Scans.

This bit does not prevent cell voltage measurements during Open Wire test or when started with the V<sub>CELL</sub> Trigger bit 0x02.0.

#### 5.3.1.2 0x02.6 DCHRWOV

Set the Discharge While Overvoltage bit to “1” to disable V<sub>CELL</sub> overvoltage detection during continuous System Scans while discharging. This setting allows the power FETs to remain on and discharging to occur if one or more cells are above the OV threshold set in register [“0x06 - 0x07 VCELL OV/UV Threshold” on page 46](#). Set this bit to “0” (default) to allow an OV to disable DFET and/or CFET (also dependent on [“0x0E.3 CPWR” on page 53](#) and [“0x24.4 CELLCON” on page 71](#)) and/or stop System Scan.

#### 5.3.1.3 0x02.5 CHRWUV

Set the Charge While Undervoltage bit to “1” to disable V<sub>CELL</sub> undervoltage detection while charging. This setting allows CFET to remain on and charging to occur if one or more cells are below the UV threshold set in register [“0x06 - 0x07 VCELL OV/UV Threshold” on page 46](#). Set this bit to “0” (default) to allow a UV to disable CFET and/or DFET (also dependent on CPWR and CELLCON) and/or stop System Scan.

#### 5.3.1.4 0x02.4:2 V<sub>CELL</sub> Averages

The V<sub>CELL</sub> Averages bits set the number of samples averaged (per cell) before writing the measurement results to their respective registers. [Table 7 on page 42](#) lists the options for these bits.

The conversion time for each V<sub>CELL</sub> measurement can be estimated as [Equation 1](#):

$$(EQ. 1) \quad V_{CELL\_CT} = (3 + (\text{SamplesToAverage})) \cdot ADC_{CT2}$$

ADC<sub>CT2</sub> is the base conversion time of the ADC (see [“Electrical Specifications” on page 14](#)).

**Table 7. V<sub>CELL</sub> Average Bits**

V <sub>CELL</sub> Averages: D[4:2]			Samples to Average
0	0	0	1
0	0	1	2
0	1	0	4
0	1	1	8
1	0	0	16
1	0	1	32
1	1	0	64
1	1	1	128

### 5.3.1.5 0x02.1 Clear Faults and Status

Write a “1” to the Clear Faults and Status bit to clear the faults and status. All bits in registers 0x63-0x69, except for [“0x67.5 CH PRESI” on page 87](#), along with all counters are cleared (set to “0”). Other register settings are maintained with this command. On completion the bit is set to “0”.

The Fault and Status bits cannot be cleared while the condition that sets them is present.

The “CH PRESI” (charger present) bit is a straight connection to the  $\overline{\text{WAKEUP}}$  pin inverted and can only be set or cleared by the status of this pin.

### 5.3.1.6 0x02.0 V<sub>CELL</sub> Trigger

A “0” to “1” transition of this bit initiates cell voltage measurements if the Busy bit is “0” and no other trigger is active, regardless of the setting of bit [“0x02.7 V<sub>CELL</sub> EN” on page 42](#). The measured cells are determined by registers [“0x04 - 0x05 Cell Select” on page 44](#). When the command bit has been received, the Busy bit ([page 40](#)) transitions from a “0” to a “1” and the trigger bit clears. The Busy bit remains set until the measurement scan is completed, and returns to a “0”.

This trigger bit is ignored in SHIP and LOW POWER Modes and can trigger sequences in IDLE or SCAN mode only. This trigger should be used in IDLE mode because Renesas recommends reserving SCAN mode for System Scans only.

## 5.3.2 0x03 I<sub>PACK</sub> Operation

I<sub>PACK</sub> Operation is a 1-byte register that controls the system behavior related to I<sub>PACK</sub> measurements and how often the open-wire test is executed.

**Table 8. 0x03 I<sub>PACK</sub> Operation Register**

Bits	D[7]	D[6:5]	D[4:2]	D[1]	D[0]
Bit Name	I <sub>PACK</sub> EN	OW Update	I <sub>PACK</sub> AVE	I <sub>DIR</sub> Delay	I <sub>PACK</sub> Trigger
Default	1	00	0 00	0	0

### 5.3.2.1 0x03.7 I<sub>PACK</sub> EN

Set this bit to “1” (default) to enable I<sub>PACK</sub> measurement during System Scans. Set to “0” to disable I<sub>PACK</sub> measurement during System Scans. This bit does not prevent I<sub>PACK</sub> measurement during open-wire detection or when started by the I<sub>PACK</sub> Trigger bit.

### 5.3.2.2 0x03.6:5 OW Update

The Open-Wire Update bits of the I<sub>PACK</sub> Operation register control how often the open-wire test is executed as part of continuous System Scans. The frequency of the open-wire test is defined in terms of System Scans in [Table 9](#).

Open-Wire operation is detailed in [“Open-Wire Function” on page 112](#) and [“Aux Pins Open-Wire Test” on page 93](#). The Aux Pins open-wire test is not controlled by the 0x03.6:5 OW Update bits or [“0x24.6 OW EN” on page 71](#) and is not triggered by [“0x24.5 OW Trigger” on page 71](#).

**Table 9. OW Update Bits**

D[6:5]		How Often the Open-Wire Test is Executed?
0	0	256 (Update on scan 1, 257, 513, 769...)
0	1	512 (Update on scan 1, 513, 1025, 1567...)
1	0	1024 (Update on scan 1, 1025, 2049, 3071...)
1	1	2048 (Update on scan 1, 2049, 4097, 6145...)

### 5.3.2.3 0x03.4:2 I<sub>PACK</sub> Averages

The I<sub>PACK</sub> Averages bits determine the number of samples averaged before writing the measurement result to its register. [Table 10](#) lists the options for these bits.

**Table 10. I<sub>PACK</sub> Averages Bits**

I <sub>PACK</sub> Averages: D[4:2]			Samples to Average
0	0	0	1
0	0	1	2
0	1	0	4
0	1	1	8
1	0	0	16
1	0	1	32
1	1	0	64
1	1	1	128

The conversion time for an I<sub>PACK</sub> measurement can be estimated as [Equation 2](#):

$$(EQ. 2) \quad I_{PACK_{CT}} = (3 + \text{SamplesToAverage}) \cdot ADC_{CT2}$$

ADC<sub>CT2</sub> is the base conversion time of the ADC (see the [“Electrical Specifications” on page 14](#)).

### 5.3.2.4 0x03.1 I<sub>DIR</sub> Delay

The Current Direction delay bit of the I<sub>PACK</sub> Operation register sets the number of consecutive current measurement readings in one direction required before setting the CHRGI or DCHRGI ([“0x67 Status” on page 87](#)) bits in SCAN mode. The default setting of “0” requires only one reading. Set this bit to “1” to require three consecutive readings in SCAN mode during continuous scans. This bit has no effect on single scans or in other operating modes.

The [“0x67.6 CHRGI” on page 87](#) and [“0x67.7 DCHRGI” on page 87](#) bits are evaluated at the end of each I<sub>PACK</sub> measurement.

For an I<sub>DIR</sub> Delay of “0”, CHRGI is set to “1” immediately if the I<sub>PACK</sub> measurement result is >208μV or it is reset to “0” if the result is <208μV. DCHRGI is set to “1” immediately if the I<sub>PACK</sub> measurement result is <-219μV or it is reset to “0” if the result >-219μV (typical voltage thresholds).

With I<sub>DIR</sub> Delay set to “1”, CHRGI is set to “1” after three consecutive I<sub>PACK</sub> measurement results >208μV or it is reset to “0” immediately if a result <208μV. DCHRGI is set to “1” after three consecutive I<sub>PACK</sub> measurement results <-219μV or it is reset to 0 immediately if a result >-219μV (typical voltage thresholds).

### 5.3.2.5 0x03.0 I<sub>PACK</sub> Trigger

A “0” to “1” transition of this bit instructs the device to start an I<sub>PACK</sub> and Delta Timer measurement. When received, the Busy bit transitions from a “0” to a “1” and the trigger bit clears. The Busy bit remains set until the action is completed and next returns to a “0”.

The I<sub>PACK</sub> Trigger bit initiates an I<sub>PACK</sub> measurement regardless of the setting of the I<sub>PACK</sub> Enable bit.

This trigger bit is ignored in SHIP and LOW POWER Modes and can trigger sequences in IDLE or SCAN mode only. It should be used in IDLE mode only as Renesas recommends reserving SCAN mode for System Scans.

## 5.3.3 0x04 - 0x05 Cell Select

The Cell Select registers indicate to the ISL94216 state machine which cells exist in the BMS. This setting determines the cells to include during V<sub>CELL</sub> scans, Open-Wire test, Cell Balancing, and System Scans. A “1” includes the cell and a “0” bypasses the cell in all functions. Unused cell locations MUST be disabled (set to “0”) before starting System Scans or triggering measurements, Open-Wire, or Cell Balancing functions.

**Table 11. 0x04 - 0x05 Cell Select Registers**

Address - Bits	0x04 - D[7:0]	0x05 - D[7:0]
Bit Name	Cell Number 16 (MSB) to 9 (LSB)	Cell Number 8 (MSB) to 1 (LSB)
Default	1111 1111	1111 1111

### 5.3.4 0x30 - 0x4F V<sub>CELL</sub> Voltage (R)

Registers 0x30 through 0x4F report V<sub>CELL</sub> measurements. The V<sub>CELL</sub> output voltage is stored across two adjacent bytes as listed in [Table 12](#).

**Table 12. V<sub>CELL</sub> Measurement Registers**

Address - Bits	0x30, 32, 34...4E - D[7:0]	0x31, 33, 35...4F - D[7:0]
Bit Name	15 (MSB) to 8 (LSB)	7 (MSB) to 0 (LSB)
Default	0000 0000	0000 0000
V <sub>CELL</sub> Step	73.55μV	

Addresses 0x30 and 0x31 contain the voltage reading for Cell 1. Locations 0x4E and 0x4F correspond to Cell 16's voltage reading.

$$(EQ. 3) \quad V_{Cell} = (RegVal) \cdot V_{CELL\_Step} + 0.5 \cdot V_{CELL\_Step}$$

Use [Equation 3](#) to calculate the cell voltage by multiplying the 16-bit register value by the step size V<sub>CELL</sub>Step and add the 1/2 LSB offset. The register records results from 36.77μV to 4.82V.

### 5.3.5 0x50 - 0x51 V<sub>CELL</sub> Max Delta Voltage (R)

The V<sub>CELL</sub> Maximum Delta registers store the difference between the maximum V<sub>CELL</sub> voltage and the minimum V<sub>CELL</sub> voltage (registers 0x30-0x4F). It is evaluated immediately after a V<sub>CELL</sub> scan completes. [Table 13](#) shows the format of these registers.

**Table 13. 0x50-51 V<sub>CELL</sub> Delta Register**

Address - Bits	0x50 - D[7:0]	0x51 - D[7:0]
Bit Name	15 (MSB) to 8 (LSB)	7 (MSB) to 0 (LSB)
Default	0000 0000	0000 0000
V <sub>CELL</sub> Step	73.55μV	

$$(EQ. 4) \quad V_{CellMaxDelta} = (RegVal) \cdot V_{CELL\_Step}$$

Calculate the Maximum Delta Voltage by multiplying the 16-bit register value by the step size V<sub>CELL</sub>Step as shown in [Equation 4](#). The register records results from 0V to 4.82V.

### 5.3.6 0x52 - 0x53 I<sub>PACK</sub> Voltage (R)

The I<sub>PACK</sub> registers hold the 16-bit 2's complement measurement result representing the I<sub>PACK</sub> sense resistor (R<sub>SHUNT</sub>) voltage. Calculate the voltage as outlined below; next, divide the result by the shunt resistance R<sub>SHUNT</sub> (see [“CSP and CSN Pins \(24, 25\)” on page 91](#)) to calculate the current.

The MSB of the 16-bit register reading (0x52.7) is the sign bit. If it is “0” then:

$$V(I_{PACK}) = (\text{Code}_{16}) \times \text{LSB} + \frac{1}{2}\text{LSB}. \text{ Otherwise,}$$

$$V(I_{PACK}) = (\text{Code}_{16} - 65536) \times \text{LSB} + \frac{1}{2}\text{LSB}$$

The LSB value is 10.51μV. Examples:

$$\text{Code}_{16} \text{ 0x0000} = \frac{1}{2}\text{LSB} = 5.25\mu\text{V}$$

$$\text{Code}_{16} \text{ 0x7FFF} = (2^{15} - 1) \times \text{LSB} + \frac{1}{2}\text{LSB} = +344.28\text{mV}$$

$$\text{Code}_{16} \text{ 0x8000} = (2^{15} - 65536) \times \text{LSB} + \frac{1}{2}\text{LSB} = -344.28\text{mV}$$

**NOTE:** Every time current is measured, the Delta Timer value is written to [“0x54 - 0x57 I<sub>PACK</sub> Timer \(R\)”](#).

### 5.3.7 0x54 - 0x57 I<sub>PACK</sub> Timer (R)

The I<sub>PACK</sub> Timer is 32 bits with a nominal step size of 15ms. It Functions as a time stamp for I<sub>PACK</sub> current measurements. When a pack current measurement is made, the value of the I<sub>PACK</sub> Timer is pushed to these registers. The timer runs in LOW POWER, IDLE, and SCAN Modes and is designed to count to two years without rolling over.

Multiply the step size  $\Delta\text{Timer}_{\text{Step}}$  by the 32-bit register value to calculate the elapsed time. The register records results from 0ms to 2.043 years. Multiplying the elapsed time between two measured currents by the current results in an electric charge value in Coulombs.

The timer is reset and begins counting immediately on POR, see [“RESET Pin \(38\)” on page 94](#), [“0x01.7 Soft Reset” on page 40](#) and [“0x01.6 Reset to IDLE” on page 40](#).

## 5.4 V<sub>CELL</sub> Fault Detectors

The V<sub>CELL</sub> Fault Detectors consist of digital OV/UV comparators and fault delay timers. The digital comparators and delay timers are responsible for detecting OV/UV events while charging and discharging in SCAN mode to provide an automatic fault response. Fault response is up to the MCU in IDLE mode. [Figure 81](#) is a block diagram of the V<sub>CELL</sub> Fault Detection function.

### 5.4.1 0X06 - 0X07 V<sub>CELL</sub> OV/UV Threshold

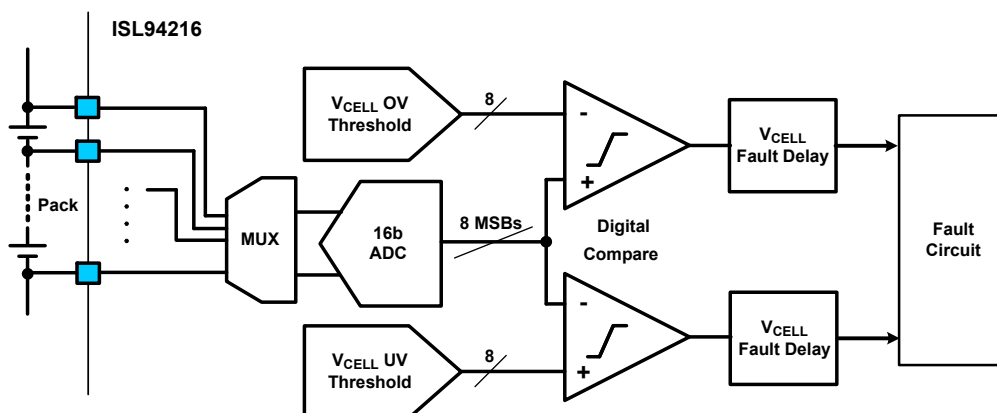

Figure 81. V<sub>CELL</sub> OV/UV Detectors

Each V<sub>CELL</sub> measurement is compared to overvoltage and undervoltage limits. During discharge, undervoltage threshold detectors alert the system to prevent discharging to a nonchargeable state. During charge, the overvoltage threshold detectors alert the system to discontinue charging at the selected voltage. These threshold

detectors only operate under charge (“[0x67.6 CHRGI](#)” on page 87) or discharge (“[0x67.7 DCHRGI](#)” on page 87) conditions. The  $V_{CELL}$  Fault Delay counters are bypassed if the part is not running in continuous scan.

The threshold detectors are digital comparators that require an ADC  $V_{CELL}$  conversion to compare. These two comparators (OV/UV) are fault detectors. If the FET control bit “[0x24.4 CELLCON](#)” on page 71 is set, a OV or UV event can shut off the power FET(s) depending on the bit settings of “[0x0E.3 CPWR](#)” on page 53, “[0x02.6 DCHRWOV](#)” on page 42, and “[0x02.5 CHRWUV](#)” on page 42. The overvoltage and undervoltage registers are shown in [Table 14](#).

**Table 14. 0x06 OV and 0x07 UV  $V_{CELL}$  Threshold Registers**

Address - Bits	0x06 - D[7:0]	0x07 - D[7:0]
Name	OV Threshold	UV Threshold
Default	1111 1111	0000 0000
$V_{thStep}$	18.83mV	
Offset	18.79mV	36.77 $\mu$ V

$OV_{thStep}$  and  $UV_{thStep}$  are the same value for both thresholds, the Offsets are different. Multiply the register value by the step size, and add the fixed offset to calculate the threshold using [Equation 5](#). The OV threshold register supports settings from 18.79mV to 4.82V while the UV threshold register supports settings from 36.77 $\mu$ V to 4.801V.

$$(EQ. 5) \quad V_{Threshold} = (RegVal) \cdot V_{thStep} + Offset$$

A  $V_{CELL}$  OV threshold violation sets the fault “[0x63.0 OVF](#)” when any cell is greater than the threshold and the device is charging. A UV threshold violation sets the fault “[0x63.1 UVF](#)” if any cell is less than or equal to the threshold and the device is discharging. These faults are gated by fault counters, see “[0x09.3:0  \$V\_{CELL}\$  Fault Delay](#)”.

#### 5.4.2 0x08 $V_{CELL}$ Max Delta Threshold

The  $V_{CELL}$  Max Delta register sets the threshold for a digital compare with the  $V_{CELL}$  Max Delta Voltage (0x50 - 0x51). The detection is used to maintain cell voltage readings within a predetermined voltage range. [Table 15](#) shows the format of this register.

**Table 15. 0x08  $V_{CELL}$  Maximum Delta Threshold Register**

Bits	D[7:0]
Bit Name	DVCMAX - $V_{CELL}$ Max Delta Threshold
Default	1111 1111
$DVCELL_{Step}$	18.83mV
Offset	18.79mV

Multiply the register value by the step size  $DVCELL_{Step}$ , and add the fixed offset to calculate the threshold using [Equation 6](#). The register supports settings from 18.79mV to 4.82V.

$$(EQ. 6) \quad V_{Threshold} = (RegVal) \cdot DVCELL_{Step} + Offset$$

A  $V_{CELL}$  Max Delta threshold violation sets the fault “[0x66.3 DVCF](#)” when any cell voltage delta is greater than the threshold. This fault is gated by a fault counter, see “[0x09.6 Delta  \$V\_{CELL}\$  Fault Delay](#)”.



### 5.4.3 0x09 Fault Delay

When a fault is detected, the ISL94216 reacts following a set delay. The delay to report a fault is a function of the ADC conversion time, the functions included in scans, the type of scan, and the Fault Delay register settings (if in continuous scan). The fault delays are user-programmable scan counters that are active only during continuous scans. [Table 16](#) shows the format of this register.

**Table 16. 0x09 Fault Delay Register**

Bits	D[7]	D[6]	D[5]	D[4]	D[3:0]
Bit Name	AUX Pull-up	DV <sub>CELL</sub> Fault Delay	Other Fault Delay	ETAUX Fault Delay	V <sub>CELL</sub> Fault Delay
Default	0	0	0	0	0000

#### 5.4.3.1 0x09.7 AUX/xTn Pull-Up

When the Auxiliary input Pull-Up bit is “1”, an internal test resistor ( $R_{ETAUX}$ , [page 15](#)) is connected between AUX0/xT0 and VCC and another between AUX1/xT1 and VCC.

The resistors should only be connected to conduct an open-wire test of the AUX0/xT0 and AUX1/xT1 pins and disconnected during normal operation by setting it back to “0” (default). See [“Aux Pins Open-Wire Test” on page 93](#) for details about the operation of this bit.

#### 5.4.3.2 0x09.6 Delta V<sub>CELL</sub> Fault Delay

The DV<sub>CELL</sub> fault detector has a scan delay counter gating the output of the DV<sub>CELL</sub> Voltage threshold comparator when the device is in continuous SCAN mode. These counters are bypassed during single triggered scans. The DV<sub>CELL</sub> Fault Delay is set to either a single failure (default of “0”) or three consecutive scan failures (if set to “1”) required. The selected count must be met during continuous scan before a fault is reported.

#### 5.4.3.3 0x09.5 Other Fault Delay

When the ISL94216 is in continuous SCAN mode, the Other Fault Delay bit controls individual scan delay counters that gate the output of the following fault comparators; [“0x63.7 VCCF” on page 79](#), [“0x67.0 VTMPF” on page 88](#), [“0x67.2 IREG1” on page 88](#), [“0x67.1 IREG2” on page 88](#), [“0x65.7 VBOVF” on page 83](#), [“0x65.6 VBUVF” on page 83](#), [“0x63.5 IOTF” on page 80](#), and [“0x66.6 IOTW” on page 85](#). The scan delay count can be set to either a single failure (default setting of “0”) or three consecutive scan failures (if set to “1”) before setting the fault bit. The selected count of consecutive errors must be met during continuous scan before a fault is reported. These counters are bypassed during single triggered scans.

#### 5.4.3.4 0x09.4 ETAUX Fault Delay

The ETAUX fault detector has a scan delay counter gating the output of the ETAUX Voltage threshold comparators when the device is in continuous SCAN mode, these counters are bypassed during single triggered scans. The ETAUX Fault Delay is set to either a single (default of “0”) or three consecutive scan failures (if set to “1”) required. The selected count must be met during continuous scan before a fault is reported.

#### 5.4.3.5 0x09.3:0 V<sub>CELL</sub> Fault Delay

The V<sub>CELL</sub> Fault Delay bits set the required count of consecutive V<sub>CELL</sub> scans with a Cell OV or UV failure before a fault is reported (see [“0x06 - 0x07 VCELL OV/UV Threshold” on page 46](#)). This delay counter is only functional when the device is running continuous System Scans and a charge ([“0x67.6 CHRGI” on page 87](#)) or discharge current ([“0x67.7 DCHRGI” on page 87](#)) is detected. These counters are bypassed during single triggered scans. If the device is in continuous SCAN mode and a cell voltage is outside the limits during consecutive measurements that exceeds the V<sub>CELL</sub> Fault Delay setting, a fault is reported. The V<sub>CELL</sub> Fault Delay count threshold is the decimal value of these bits plus 1. The range is between 1 scan (default setting of “0000”) and 16 scans (setting of “1111”).



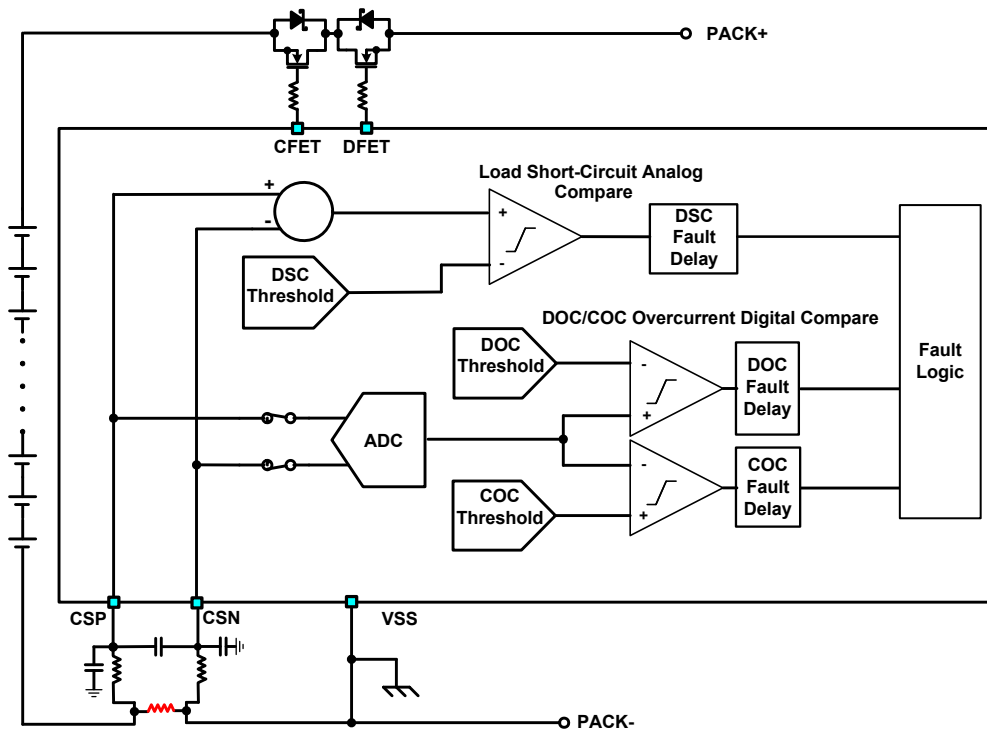

Figure 82. Current Sense Block Diagram

### 5.5 I<sub>PACK</sub> Fault Detectors

The I<sub>PACK</sub> Fault Detectors consist of a short-circuit analog comparator and two digital overcurrent comparators. The analog comparator disconnects the battery pack from the load when a short-circuit is detected. The comparator is operational in all modes except in SHIP. The digital comparators are responsible for detecting overcurrent events while charging and discharging. [Figure 82](#) is a block diagram of the I<sub>PACK</sub> Fault Detection function.

#### 5.5.1 0x0A DSC Threshold

The Discharge Short-Circuit Threshold register sets the short-circuit threshold of the analog comparator. [Table 17](#) shows the format of the Discharge Short-Circuit Threshold register. Short-circuit detection is disabled by setting the register to 0x00. **Note:** This is for test purposes and is not recommended for normal operation.

Table 17. 0x0A DSC Threshold Register

Bits	D[7:4]	D[3:0]
Bit Name	RSV	DSC Discharge Short-Circuit Threshold
Default	0000	1111
VDSC <sub>Step</sub>		-40.167mV
Offset		-40.167mV
Min Threshold (0x0A.[3:0] = 0001)		-80.33mV

Multiply the register value by the step size VDSC<sub>Step</sub> and subtract the fixed offset to calculate the threshold for non-zero settings using [Equation 7](#). The register supports settings from -80.33mV to -642mV (typical). This register represents a negative value without a sign bit. If the voltage across the current sense resistor (see [“CSP and CSN Pins \(24, 25\)”](#)) is more negative than this threshold for more than [“0x0C DSC Delay”](#), then fault bit [“0x63.2 DSCF”](#) is set. See [“Short-Circuit Detection and Recovery”](#) for a detailed description of the relationship between the DSC Threshold, DSC Delay and [“0x0E.4 ELR”](#).

$$(EQ. 7) \quad V_{Threshold} = ((RegVal) \cdot VDSC_{Step}) + Offset$$

## 5.5.2 0x0B DOC Threshold

The Discharge Overcurrent Threshold register sets the overcurrent threshold of a digital comparator. [Table 18](#) shows the format of this register.

**Table 18. 0x0B DOC Threshold Register**

Bits	D[7:0]
Bit Name	DOC - Discharge Overcurrent Threshold
Default	1111 1111
VDOC <sub>Step</sub>	-1.345mV
Offset	-5.25μV

The comparator for overcurrent detection relies on ADC conversions in addition to a number of System Scans. If the measurement is continuously above the threshold after the selected number of scans occurs (see [“0x0D OC Delay” on page 51](#)), then a fault is asserted.

$$(EQ. 8) \quad V_{Threshold} = ((RegVal) \cdot VDOC_{Step}) + Offset$$

Multiply the register value by the step size VDOC<sub>Step</sub> and subtract the fixed offset to calculate the threshold [Equation 8](#). The register supports settings from -5.25μV to -342.95mV. This register represents a negative value without a sign bit.

If the voltage across the current sense resistor (see [“CSP and CSN Pins \(24, 25\)” on page 91](#)) is less than or equal to this threshold for more than [0x0D.7:4 DOCD](#) Scans during discharge, then the fault bit [“0x63.3 DOCF” on page 80](#) is set and continuous scan is halted. If bit [“0x0E.7 CFD” on page 52](#) is set, then DFET is also shut off.

## 5.5.3 0x0C DSC Delay

The Discharge Short-Circuit Delay register sets the delay time for short-circuit current detection. If the short-circuit remains (as determined by the 0x0A DSC threshold) after the delay has timed out, it shuts off the DFET and sets the fault bit [“0x63.2 DSCF” on page 80](#). [Table 19](#) outlines the Discharge Short-Circuit Delay register.

**Table 19. 0x0C Discharge Short-Circuit Delay Register**

Bits	D[7]	D[6:0]
Bit Name	RSV	DSC - Discharge Short-Circuit Delay
Default	0	000 0000
DSC <sub>Step</sub>		31.25μs

There is a fixed delay of 100-125μs between DSC comparator detection and  $\overline{ALRT}$  assertion if the DSCF Mask bit is clear ([“0x83 Priority Fault Mask” on page 81](#)), otherwise  $\overline{ALRT}$  is not asserted. The comparator output detection and  $\overline{ALRT}$  assertion is delayed by this fixed delay plus the selected delay. The device acts to shut off the power FETs ~125μs after  $\overline{ALRT}$  asserts. The total delay is composed of these two fixed delays of ~250μs plus the selected delay.

Multiply the 7-bit register value by the step size DSC<sub>Step</sub> (31.25μs) then add the fixed delay to calculate the total delay. The register supports additional delay values from 0μs to 3968.75μs. Set this register to 0x00 for no DSC Delay.

### 5.5.3.1 Short-Circuit Detection and Recovery

When a discharge current exceeds the DSC Threshold for longer than the DSC Delay setting, the bit [“0x63.2 DSCF” on page 80](#) is set to “1” and the DFET is shut off. The DSCF bit is cleared by either the load detection circuitry or by writing a “0” to the bit. **Note:** Do not clear the DSCF bit until the load is removed and a pack current measurement confirms the current was shut off.

If the load detection (“0x0E.6:5 ELD” on page 52) and recovery functions (“0x0E.4 ELR” on page 53) are enabled, the load recovery circuitry checks if the load (or short) has been removed (Figure 83). This happens after a nominal delay of  $t_{LDEN}$  (~256ms, page 15) following the shutoff of the DFET. An on-chip pull-up resistor determined by the ELD setting (“0x0E.6:5 ELD” on page 52) is connected between the LDMON and  $V_{BAT2}$  pins. After LD Delay (“0x1B.3:2 LD Delay” on page 64) the LDMON voltage is compared to the  $V_{LDThr}$  threshold (1.2V nominal, page 15). If the LDMON voltage is less than the threshold, the load is considered present and bit “0x67.4 LD PRESI” on page 88 is set. The load recovery circuitry is looking for a no load present before clearing the DSCF bit. When the voltage at the LDMON pin is above  $V_{LDThr}$ , and the DSC comparator no longer indicates the current is above the “0x0A DSC Threshold” on page 49 setting, both the DSCF and LDPRESI bits are cleared and DFET is allowed to turn on. **Note:** The unsigned DSC Threshold represents a negative voltage because the discharge current generates a negative voltage across the current sense resistor.

The DFET output is not automatically turned back on when DSCF clears; it should be turned on by the microcontroller only following confirmation that the short-circuit is no longer present. The DSCF bit cannot be cleared by the user while the Short-Circuit Recovery Sequence is in progress.

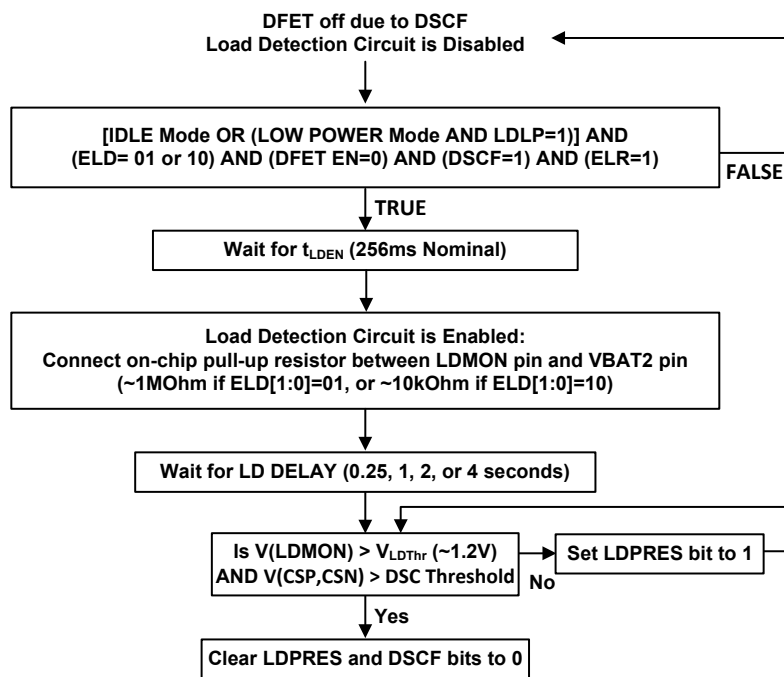

Figure 83. Simplified Short-Circuit Recovery Sequence

### 5.5.4 0x0D OC Delay

The Overcurrent Delay register defines the delay in terms of System Scans for charge and discharge overcurrent detection. The delay function only operates when the device is in SCAN mode during a continuous scan, the delay is ignored in single triggered scans. Table 20 details the Overcurrent Delay register.

Table 20. 0x0D Overcurrent Delay Register

Bits	D[7:4]	D[3:0]
Bit Name	DOCD - Discharge Overcurrent Delay	COCD - Charge Overcurrent Delay
Default	0000	0000

### 5.5.4.1 0x0D.7:4 DOCD

The Discharge Overcurrent Delay bits select the number of consecutive System Scans with a DOC threshold violation ([“0x0B DOC Threshold” on page 50](#)) that is required before it is reported to the DFET control circuitry and fault bit [“0x63.3 DOCF” on page 80](#) is set. The number of System Scans can be programmed to between 1 and 15 scans. If this register is set to “0000”, the fault is declared as soon as detected, a setting of “0001” or higher delays the fault declaration until the end of the selected number of scans.

### 5.5.4.2 0x0D.3:0 COCD

The Charge Overcurrent Delay bits select the number of consecutive System Scans with a COC threshold violation ([“0x0F COC Threshold” on page 55](#)) that is required before it is reported to the CFET control circuitry and fault bit [“0x63.4 COCF” on page 80](#) is set. The number of System Scans can be programmed to between 1 and 15 scans. If this register is set to “0000”, the fault is declared as soon as detected, a setting of “0001” or higher delays the fault declaration until the end of the selected number of scans.

## 5.5.5 0x0E Load/Charge Operations

This register is responsible for controlling various operations relevant to load and fault detection during charging and discharging and their relationship to the power FET drivers. Allocation of the Load/Charge Operations register is detailed in [Table 21](#).

**Table 21. 0x0E Load/Charge Operations Register**

Bits	D[7]	D[6:5]	D[4]	D[3]	D[2]	D[1]	D[0]
Bit Name	CFD	ELD	ELR	CPWR	FCDC	LDLP	RSV
Default	1	01	1	0	1	0	0

### 5.5.5.1 0x0E.7 CFD

The Connect for Discharge fault bit of the Load/Charge Operations register connects a discharge overcurrent detection ([“0x0B DOC Threshold” on page 50](#)) to the FET Driver when set to “1” (default). This allows the FET Driver to automatically turn off the power FET(s) if a DOC fault occurs during discharge ([“0x67.7 DCHRG1” on page 87](#) is “1”).

Setting bit CFD to “0” prevents a DOCF ([“0x63.3 DOCF” on page 80](#)) from shutting off the power FET(s), transferring responsibility to the MCU.

A DOCF stops the continuous scan regardless of the setting of CFD.

Bit [“0x0E.3 CPWR” on page 53](#) determines if DFET or both DFET and CFET are turned off and System Scan is stopped.

### 5.5.5.2 0x0E.6:5 ELD

The Enable Load Detection bits configure the load detection circuitry. [Table 22](#) shows the configuration options of the ELD bits. ELR is ignored and automatic load recovery is not performed if the ELD bits are set to “00”.

Load detection is described further in [“LDMON Pin \(49\)” on page 96](#) and [“Load Detection” on page 54](#).

**Table 22. ELD Bits**

D[6:5]		ELD
0	0	Do Not Enable Load Detection
0	1	Load Detection Enabled with 1MΩ Pull Up to V <sub>BAT2</sub>
1	0	Load Detection Enabled with 10kΩ Pull Up to V <sub>BAT2</sub>
1	1	RSV

Leakage current when a load is not connected to a battery pack is often dependent on the protection circuitry on the load side of DFET. The amount of leakage usually increases with pack voltage and current rating. Too much

leakage can cause a false load detection. The maximum pull-down leakage current that does not trigger a false load detection is defined by [Equation 9](#). The maximum leakage current before load detect is dependent on pack voltage,  $V_{LDThr}$  ([page 15](#)) and  $R_{LDPU}$  ([page 15](#)) resistance.

$$(EQ. 9) \quad (\text{LeakageCurrent(Max)}) < (V_{BAT} - V_{LDThr(Max)}) / (R_{LDPU(Max)})$$

**Note:** About Off-Chip Protection Resistor at the LDMON pin and DFET:

When the DFET is off and the load pull-up resistor is 10k $\Omega$ , it is possible to turn on DFET if the value of  $R_{LDISO}$  is too high. [Figure 93 on page 70](#) illustrates DFET interacts with the load monitor pin. When the DFET is off, a switch connects  $R_{DFOFF}$  ([page 16](#)) between the two pins. The LDMON pull-up resistor,  $R_{LDPU}$  ([page 15](#)), is also connected. If  $R_{LDISO}$ 's value ([page 15](#)) is high enough, a large enough voltage between the gate and source of the DFET when Pack+ is close to ground can cause the DFET to turn on. To prevent this from happening, size  $R_{LDISO}$  to keep the VGS of the FET low enough to remain off but as high as possible for maximum protection.

### 5.5.5.3 0x0E.4 ELR

The Enable Load Recovery bit enables the load recovery function. If a short-circuit is detected, the load recovery circuitry tests for load removal after a fixed delay of  $t_{LDEN}$  ([page 15](#)) plus a selectable delay of  $t_{LDDELAY}$  ("[0x1B.3:2 LD Delay](#)" on [page 64](#)) following the shut off of DFET (default setting of "1"). If set to "0", no load recovery test is executed and the DFET remains off until the MCU resolves the issue.

If ELR is enabled when a DSCF occurs, and the load recovery function determines if the load was removed, then the DSCF bit is automatically cleared. This function does not re-enable the DFET. See "[Short-Circuit Detection and Recovery](#)" on [page 50](#) for a detailed description of the relationship between the DSC Threshold, DSC Delay and ELR.

**Note:** If the ELD bits are set to 00 ([Table 22 on page 52](#)), ELR is ignored and a load recovery is not performed.

### 5.5.5.4 0x0E.3 CPWR

The Configure Power FET bit configures the ISL94216 for either a series (default setting of "0") or parallel (if set to "1") CFET and DFET configuration ([Figure 84](#)). This setting determines whether one or both CFET and DFET are shut off and if System Scan stops when certain indicators and/or Faults are set to "1". The CPWR bit has no effect on short-circuit events, or events not directly related to charge or discharge.

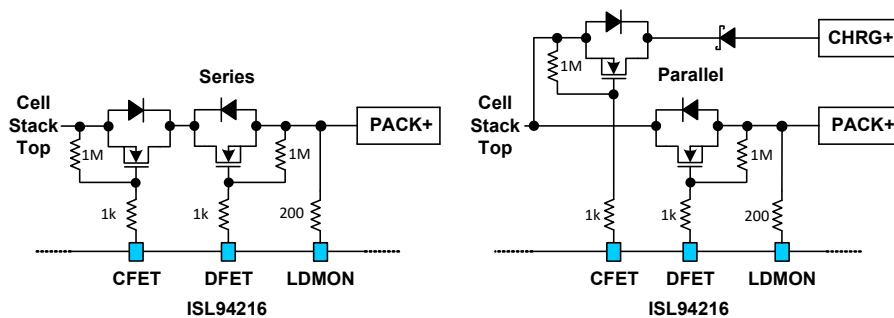

Figure 84. Power FET Configurations

See "[CFET and DFET Pins \(50, 51\)](#)" on [page 97](#) for complete details about the CPWR, fault, and control bits as they relate to FET control. See "[Scan Will Not Start](#)" on [page 111](#) for information about how the CPWR setting effects System Scan.

### 5.5.5.5 0x0E.2 FCDC

The FET Charge Driver Connect bit of the Load/Charge Operations register connects the charge overcurrent ("[0x0F COC Threshold](#)" on [page 55](#)) fault to the FET Driver when set to "1" (default). This allows the FET Driver to automatically turn off CFET when a COC fault ("[0x63.4 COCF](#)" on [page 80](#)) occurs. When  $FCDC = 1$ ,  $CPWR = 1$  and  $COCF = 1$ , the CFET is turned off. When  $FCDC = 1$ ,  $CPWR = 0$ , and  $COCF = 1$ , both CFET and DFET are turned off and System Scan stops.

Setting this bit to “0” prevents a COCF from shutting off CFET (and DFET if CPWR = 0), transferring responsibility to the MCU. A COCF causes continuous scan to halt regardless of the setting of FCDC.

**5.5.5.6 0x0E.1 LDLP**

The Load Detect while in LOW POWER mode bit keeps the load detection circuit off when the ISL94216 is in LOW POWER mode with the default setting of “0”. Setting the bit to “1” allows turning on load detection with bits “0x0E.6:5 ELD” on page 52 while in LOW POWER mode. When LDLP is enabled a detection causes the ISL94216 to transition to IDLE mode.

This bit has no effect on other modes. See “Load Detection” for more details.

**5.5.5.7 0x0E.0 RSV**

The Reserve bit should be ignored during a read command and should be set to “0” during a write command.

**5.5.5.8 Load Detection**

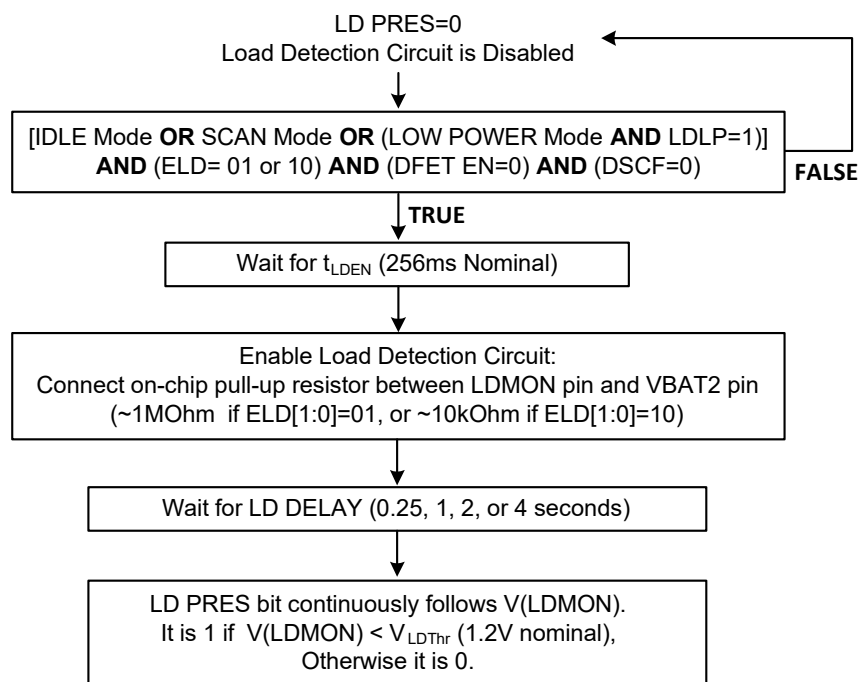

**Figure 85. Simplified Load Connection Detection Sequence**

The Load Connection Detection state machine only operates when DFET is off. The LDMON circuit is disabled when DFET is turned on. The load detection circuit includes an analog comparator and a pull-up resistor to V<sub>BAT2</sub>.

When the DFET transitions to the off state, the LD PRESI bit is cleared (see “0x67.4 LD PRESI” on page 88). After a nominal delay of t<sub>LDEN</sub> (~256ms, page 15) following DFET turn off an on-chip pull-up resistor determined by the ELD setting (0x0E.6:5) is connected between the LDMON and V<sub>BAT2</sub> pins. After LD Delay (“0x1B.3:2 LD Delay” on page 64) the LD PRESI bit continuously follows the LDMON voltage. It is “1” when the voltage is below V<sub>LDThr</sub> (1.2V nominal, page 15) or “0” otherwise.

The load detection circuit operates in SCAN and IDLE modes if enabled by the ELD bits 0x0E.6:5, and in LOW POWER mode if also enabled by LDLP bit 0x0E.1.

### 5.5.6 0x0F COC Threshold

The Charge Overcurrent Threshold register sets the overcurrent threshold of a digital comparator. [Table 23](#) shows the format of this register. If the measurement is continuously above the threshold after the selected number of scans expires (see [“0x0D OC Delay” on page 51](#)), then a fault is asserted.

**Table 23. 0x0F Charge Overcurrent Threshold Register**

Bits	D[7:0]
Bit Name	COC - Charge Overcurrent Threshold
Default	1111 1111
VCOC <sub>Step</sub>	1.345mV
Offset	5.25μV

The comparator for overcurrent detection relies on ADC conversions in addition to a number of System Scans set by [“0x0D.3:0 COCD” on page 52](#). If the I<sub>Pack</sub> voltage continuously measures greater than or equal to this threshold after the selected number of scans occurs, then fault bit [“0x63.4 COCF” on page 80](#) is asserted and continuous scan is halted. If bit [“0x0E.2 FCDC” on page 53](#) is set, the CFET is automatically shut off. See [“Charge Overcurrent Detection” on page 55](#) and [Table 20 on page 51](#).

$$(EQ. 10) \quad V_{Threshold} = (RegVal) \cdot VCOC_{Step} + Offset$$

Multiply the register value by the step size VCOC<sub>Step</sub> add the fixed offset to calculate the threshold ([Equation 10](#)). The register supports settings from 5.25μV to 342.95mV.

#### 5.5.6.1 Charge Overcurrent Detection

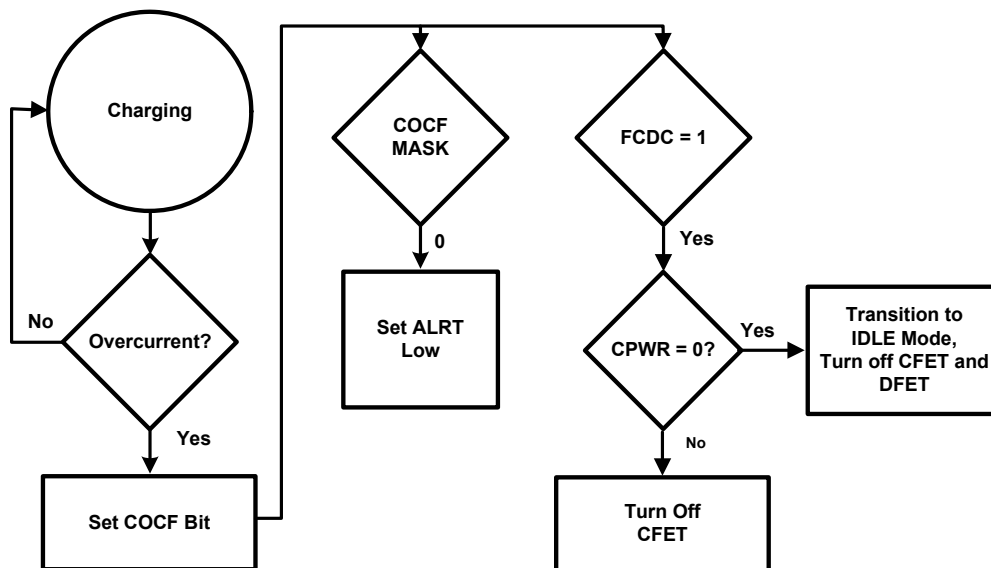

**Figure 86. COC Detect Flow Diagram**

When the ISL94216 detects an overcurrent condition while charging for the number of consecutive System Scans set by COCD ([“0x0D.3:0 COCD” on page 52](#)), fault bit [“0x63.4 COCF” on page 80](#) is set. If the COCF Mask bit is clear, then the ALRT pin goes low. If the FET Charge Driver Connect bit ([“0x0E.2 FCDC” on page 53](#)) is set, then CFET is automatically turned off. If CPWR = 0 ([“0x0E.3 CPWR” on page 53](#)), then DFET also turns off and the chip transitions to IDLE mode.

The FET off state is the responsibility of the MCU when FCDC = 0. A COCF causes continuous scan to halt regardless of the setting of FCDC. [Figure 86](#) is the flow diagram for charge overcurrent detection and response.

## 5.6 ETAUX Port

Figure 87 shows the typical configuration of the External Temperature/Auxiliary (ETAUX) port with two external thermistors.

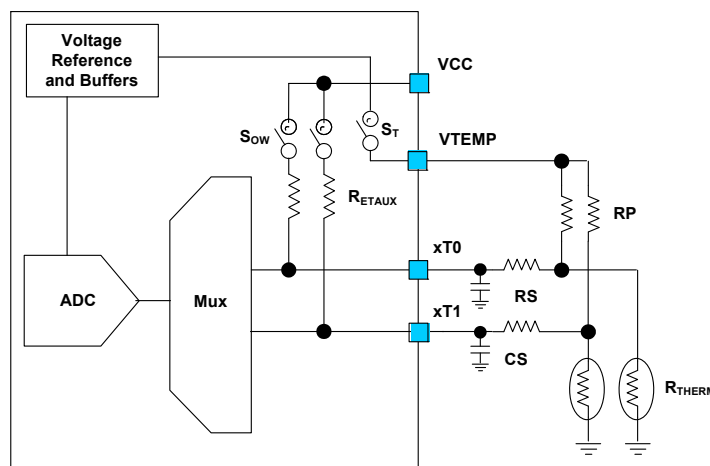

Figure 87. ETAUX Port Configured to Measure External Temperature

The ISL94216 ETAUX port consists of two analog input pins (xT0, xT1) that support two external thermistors, plus the VTEMP reference pin. Negative Temperature Coefficient thermistors (NTCs) are typically used to measure temperature within the battery pack.

Battery cell temperature is monitored for safety purposes due to battery type and chemistry limits on when to allow charge or discharge. Other potential thermal monitoring locations are the DFET, CFET, or the current sense resistor.

### 5.6.1 0x11 ETAUX Operation

The ETAUX Operation register controls the data acquisition behavior of the ETAUX inputs within the ISL94216.

Table 24. 0x11 ETAUX Operation Register

Bits	D[7:6]	D[5]	D[4:2]	D[1]	D[0]
Bit Name	ETAUX EN	RSV	ETAUX Averages	RSV	ETAUX Trigger
Default	11	0	0 00	0	0

#### 5.6.1.1 0x11.7:6 ETAUX Enable

If set to “1” (default), the ETAUX Enable bits include voltage measurement of the ETAUX pins xT0 and xT1 in SCAN mode. Set one or both bits to “0” to bypass measurement of the related pin during System Scans. See Table 25 for more information.

An “0x11.0 ETAUX Trigger” executes measurement of the enabled pins in IDLE or SCAN Mode.

Table 25. ETAUX Enable

D[7:6]		ETAUX Enable
0	0	ETAUX is Not Part of the System Scan
0	1	xT0 is Part of the System Scan
1	0	xT1 is Part of the System Scan
1	1	xT0 and xT1 is Part of the System Scan

#### 5.6.1.2 0x11.5,1 RSV

Reserve Bits 5 and 1 should be ignored during a read command and should be set to “0” during a write command.



**5.6.1.3 0x11.4:2 ETAUX Averages**

The ETAUX Averages bits determine the number of samples averaged per measurement before reporting the results to the respective registers. The ETAUX averages bits control averaging for xT0 and xT1 measurements only. [Table 26](#) lists the options for these bits.

**Table 26. ETAUX Averages**

ETAUX Averages: D[4:2]			Samples to Average
0	0	0	1
0	0	1	2
0	1	0	4
0	1	1	8
1	0	0	16
1	0	1	32
1	1	0	64
1	1	1	128

**5.6.1.4 0x11.0 ETAUX Trigger**

A “0” to “1” transition of this bit in IDLE mode starts an ETAUX measurement. When received, the Busy bit transitions from “0” to “1” and the trigger bit clears. The Busy bit remains set until the action is completed and then returns to “0”.

This trigger bit is ignored in SHIP and LOW POWER Modes and can trigger sequences in IDLE or SCAN mode only. This trigger should be used in IDLE mode because Renesas recommends reserving SCAN mode for System Scans only.

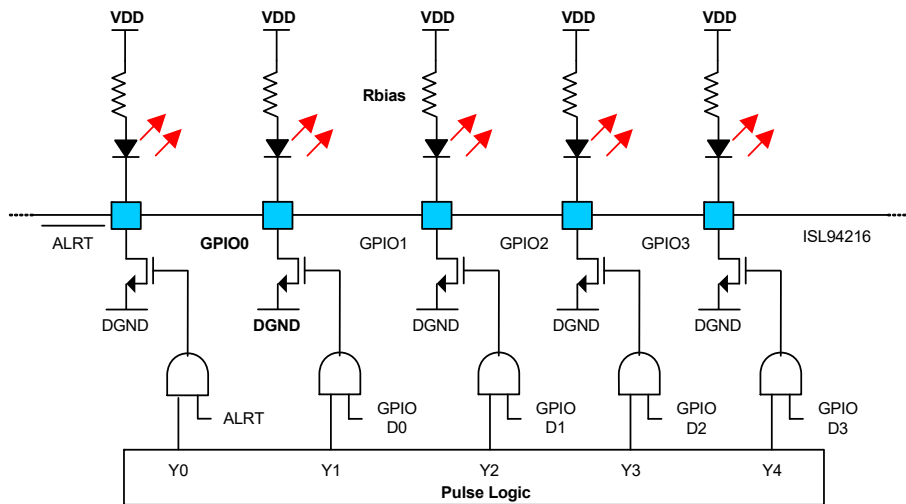

**Figure 88. ALRT Pulse EN and GPIOx Drive LEDs**

**5.7 0x12 ALRT and GPIO**

This register displays the status of the GPIO pins and configures the GPIO port and the ALRT pin.

**Table 27. 0x12 GPIO and ALRT Operation Register**

Bits	D[7]	D[6]	D[5:4]	D[3:0]
Bit Name	ALRT Assert	ALRT PULSE EN	GPIO Config	GPIO Status
Default	0	0	01	1111

### 5.7.1 0x12.7 $\overline{\text{ALRT}}$ Assert

The  $\overline{\text{ALRT}}$  Assert bit forces the  $\overline{\text{ALRT}}$  pin state to a low when the bit is set to “1”. Clear the bit (default “0”) to return the  $\overline{\text{ALRT}}$  pin to normal operation. This bit enables testing of the connection between the  $\overline{\text{ALRT}}$  pin and microcontroller.

### 5.7.2 0x12.6 $\overline{\text{ALRT}}$ Pulse EN

The  $\overline{\text{ALRT}}$  Pulse Enable bit can be used to drive the  $\overline{\text{ALRT}}$  pin in a more power efficient manner. When the bit is “1” and an alert is active, the ISL94216 turns on the  $\overline{\text{ALRT}}$  pin output pull-down device for GPIOpulse\_on (~2ms, [page 17](#)) within a GPIOpulse\_per (~10ms, [page 17](#)) period. When this bit is “0” (Default) and an alert is active, the ISL94216 drives the  $\overline{\text{ALRT}}$  pin LOW constantly. [Figure 88](#) illustrates the circuit.

### 5.7.3 0x12.5:4 GPIO CONFIG

GPIO Configuration bits allow the GPIO pins to be used as digital inputs, digital outputs, LED drivers, or as outputs to drive external power FET circuits. [Table 28](#) shows the possible configurations of the GPIO port.

**Table 28. GPIO Configuration Bits**

D[5:4]	GPIO Configuration
00	Digital Inputs
01	Digital Outputs
10	Drive LED
11	Power FETs Gate Drive Out

See [“0x12.3:0 GPIO STATUS”](#) for Digital Input and Output configurations.

**Drive LED:** This option pulses the GPIO pins in a sequential manner to save power. Each GPIO pin is set LOW for GPIO\_pulse\_on (~2ms, [page 17](#)) within a GPIO\_pulse\_per (~10ms, [page 17](#)) period. A simplified schematic is shown in [Figure 88](#). See [“0x12.3:0 GPIO STATUS”](#) to set the state of GPIO output. Set the GPIO Status bit to “1” to light an LED or to “0” to shut it off.

**Power FETs Gate Drive Out:** This selection enables the ISL94216 to be designed with a low side FET configuration. It connects GPIO2 to the DFET state and GPIO3 to the CFET state. These states are dependent on bits [“0x24.1 DFET EN”](#) and [“0x24.0 CFET EN”](#) on [page 72](#) along with other settings and faults as described in [“CFET and DFET Pins \(50, 51\)”](#) on [page 97](#). The DFET and CFET states follow the same expected behavior of the DFET and CFET pins except that the state does not depend on the charge pump. That means the state can be “On” (LOW) even when the [“0x24.7 CPMP EN”](#) on [page 70](#) bit is “0” and/or the [“0x65.5 CPMP NRDY”](#) on [page 83](#) bit is “1” even though the high-side DFET and CFET pins are off. [Table 29](#) defines the logic state of the GPIO output pins (3, 2, 0) as a function of the GPIO1 input, the device Mode, and the internal DFET and CFET enable bits.

GPIO1 is configured as a FETs Off digital input pin. If the logic input is high, both DFET and CFET GPIO pins, along with the high-side DFET and CFET pins (if enabled), turn off. If the logic input is low, the DFET and CFET states pass to GPIO2 and GPIO3. Prior to choosing this configuration, disable both CFET and DFET by setting their enable bits to “0”; next, write 0x3E to register 0x12.

GPIO0 is configured as a FETs ON digital output pin. The output of the pin is LOW when CFET and DFET are both off. It is high impedance when one or both of the CFET and DFET GPIO outputs are “On”.

**Table 29. GPIO Pins Logic States in FETs Out Mode**

Internal State Variable			Input Pin	Output Pins		
Mode	DFET	CFET	FETs Off (GPIO1)	FETs On (GPIO0)	DFET (GPIO2)	CFET (GPIO3)
SCAN or IDLE	OFF	OFF	LOW	LOW	HI-Z	HI-Z
	OFF	ON	LOW	HI-Z	HI-Z	LOW
	ON	OFF	LOW	HI-Z	LOW	HI-Z
	ON	ON	LOW	HI-Z	LOW	LOW
	X	X	HIGH	LOW	HI-Z	HI-Z
LOW POWER or SHIP	X	X	X	HI-Z	HI-Z	HI-Z

### 5.7.4 0x12.3:0 GPIO STATUS

The GPIO Status bits report the status of each GPIO pin. The GPIO Status bits are read only when configured as inputs. Reading these bits returns the input status of the GPIO pins.

If the GPIO pins are set up as Digital outputs, then writing to these bits sets the GPIO pins state. Set a GPIO Status bit to “0” to pull the output pin low or to “1” to release it.

In Drive LED mode, set a GPIO Status bit to “1” to light an LED or to “0” to shut it off. The GPIO pins are connected to open-drain NMOS transistors designed to drive 2mA nominal LEDs. **Note:** Drive LED and Digital Output modes force the outputs to the opposite level given the same bit setting.

## 5.8 ETAUX Detectors

The ETAUX Detectors are threshold comparators that detect over-temperature and under-temperature conditions based on readings from the xT0 and xT1 pins. The ETAUX Fault Delay counters are bypassed if the part is not running in continuous SCAN mode. [Figure 89](#) is the block diagram of the ETAUX fault detection function.

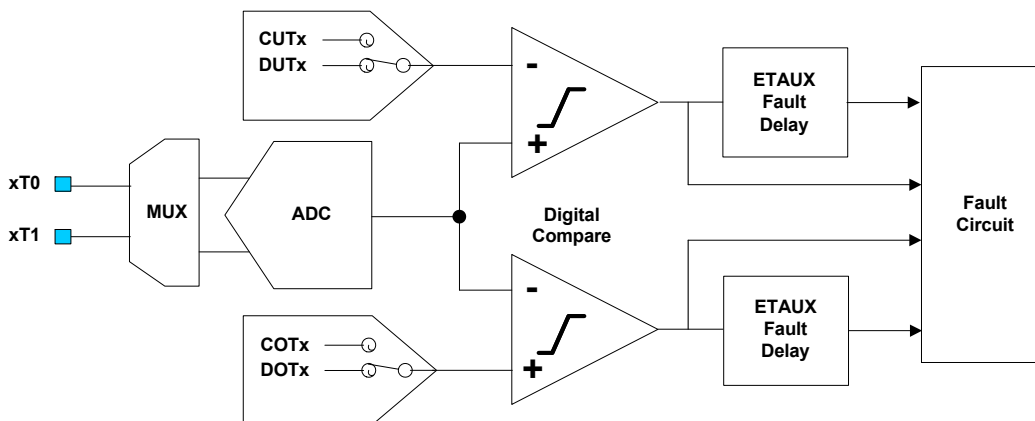

**Figure 89. ETAUX Fault Detector Block Diagram**

### 5.8.1 0x13-1A ETAUX Thresholds

The Under-Temperature and Over-Temperature ETAUX fault detectors consist of two digital comparators with four digital thresholds for each ETAUX (xT0 or xT1) input. The device has two sets of limits to which the ETAUX readings are compared based on whether the pack is charging or discharging.

The thresholds for overvoltage (UT) and undervoltage (OT) are set by programming the CUTn, DUTn, COTn, and DOTn (n = 0 for AUX0/xT0 and n = 1 for AUX1/xT1) registers. [Table 30](#) and [Table 31](#) show the format of these registers.

**Table 30. 0x13, 15, 17, 19 (D,C) UT Threshold Registers**

Bits	D[7:0]
Name	UT (OV) Threshold [7 to 0]
Default	1111 1111
ETAUX <sub>thstep</sub>	6.276mV
Offset	6.263mV

**Table 31. 0x14, 16, 18, 1A (D,C) OT Threshold Registers**

Bits	D[7:0]
Name	OT (UV) Threshold [7-->0]
Default	0000 0000
ETAUX <sub>thstep</sub>	6.276mV
Offset	6.263mV

To calculate the threshold voltage for all COT, DOT, CUT, and DUT registers, multiply the register value by the step size ETAUX<sub>thstep</sub>, and add the offset ([Equation 11](#)). The registers support settings from 6.263mV to 1606.67mV.

$$(EQ. 11) \quad V_{Threshold} = (RegVal) \cdot ETAUX_{thStep} + Offset$$

Eight associated Fault/Indicator bits are located at Register Address ["0x64 ETAUX Fault" on page 81](#). Each of the bits is linked to a UT or OT threshold register. Each time the ISL94216 measures AUX1/xT1 and AUX0/xT0 voltages (["0x58-59 xT0, 0x5A-5B xT1 \(R\)"](#)), the results are compared to the relevant thresholds. If the external voltage is greater than the relevant UT threshold or less than or equal to the relevant OT threshold, the appropriate Fault/Indicator bit is set.

Each Fault/Indicator bit has a masking bit (see ["0x84 ETAUX Fault Mask" on page 83](#)) that connects the Fault/Indicator bit to the ALRT pin if cleared (set to "0"/ The default is "1").

The bit ["0x24.2 ETA Connect" on page 71](#) determines if the ETAUX OT/UT faults control the power FETs automatically. These faults halt continuous scan regardless of ETA Connect.

UT thresholds detect under-temperature conditions when a pin connects to a negative temperature coefficient (NTC) circuit, or they detect overvoltage conditions when the pins are used for auxiliary input voltages.

OT thresholds detect over-temperature conditions when a pin connects to a negative temperature coefficient (NTC) circuit, or they detect undervoltage conditions when the pins are used for auxiliary input voltages.

The charge and discharge temperature comparisons are a function of bits ["0x67.6 CHRGI" on page 87](#) and ["0x67.7 DCHRGI" on page 87](#). When the CHRGI bit is set, the AUXn readings are compared to the COT and CUT thresholds. When the DCHRGI bit is set, the AUXn readings are compared to the DUT and DOT threshold.

- When  $I_{PACK} < -20$  (decimal), the chip compares  $V(xTn, VSS)$  to the COT/CUT thresholds.
- When  $I_{PACK} > 19$ , the chip compares  $V(xTn, VSS)$  to the DOT/DUT thresholds.
- When  $-20 \leq I_{PACK} \leq 19$ , the chip does not compare  $V(xTn, VSS)$  to any of the these thresholds.

If neither the CHRGI or DCHRGI bits are set, then no action is taken in SCAN mode, but in IDLE mode a violation of any of these thresholds set the related fault bit.

### 5.8.2 0x58-59 xT0, 0x5A-5B xT1 (R)

The ETAUX Voltage registers report the voltage measurement readings for the xT0 and xT1 pins. Each register is two bytes.

**Table 32. 0x58-5B ETAUX Voltage**

Register Name	xT0/AUX0		xT1/AUX1	
Address - Bits	0x58 - D[7:0]	0x59 - D[7:0]	0x5A - D[7:0]	0x5B - D[7:0]
Byte Order	MSB	LSB	MSB	LSB
ETAUX <sub>Step</sub>	24.52μV			

$$(EQ. 12) \quad xTnVoltage = (RegVal) \cdot ETAUX_{Step} + 0.5 \cdot ETAUX_{Step}$$

Multiply the 16-bit register value by the step size  $ETAUX_{Step}$ , and add the 1/2 LSB offset to calculate the voltage. The registers support values from 12.26μV to 1606.67mV.

These voltages are compared to [“0x13-1A ETAUX Thresholds”](#), violations set fault bits in register [“0x64 ETAUX Fault”](#) and stop continuous scan. If the control bit [“0x24.2 ETA Connect”](#) is set, a fault in SCAN mode shuts off power FETs depending on the setting of [“0x0E.3 CPWR”](#) and current direction. A violation of any of these thresholds in IDLE mode sets the fault bit regardless of current direction.

## 5.9 Internal Temperature

### 5.9.1 0x22 - 0x23 IOTW and IOTF Thresholds

The Internal Over-Temperature Threshold detectors allow for two limit settings on the ISL94216 die temperature. The internal temperature sensor is monitored to prevent the die from over heating.

The Internal Over-Temperature Warning (IOTW) Threshold (0x22) is the first temperature threshold. It is intended to be a warning and sets the flag [“0x66.6 IOTW”](#) when the internal temperature exceeds its temperature limit.

If the internal temperature rises above the second temperature threshold, bit [“0x63.5 IOTF”](#) is set, the power FETs are disabled, and System Scan stops.

Both the IOTW and Internal Over-Temperature Fault (IOTF) bits require [“0x09.5 Other Fault Delay”](#) consecutive measurements in violation of the limit in continuous System Scan before the fault bit is set. The Other Fault Delay counters are bypassed if the part is not running in continuous SCAN mode. [Figure 90](#) is the block diagram for the IOT detection functions.

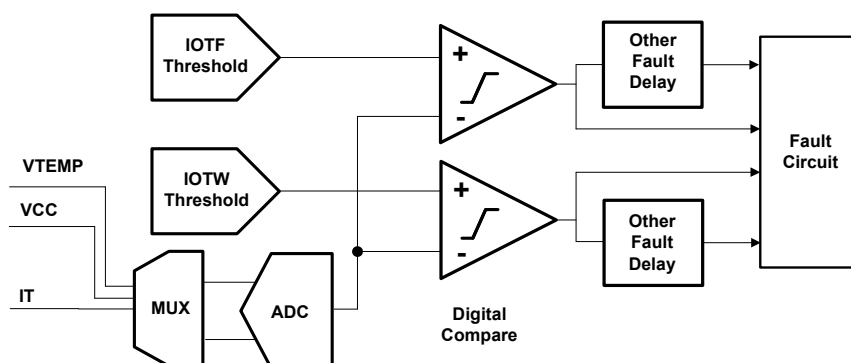

**Figure 90. IOT Fault Detectors**

[Table 33](#) shows the format of these registers.

**Table 33. 0x22, 0x23 IOT Threshold Registers**

Register	Bits D[7:0]
0x22: Internal Over Temperature Warning Threshold	0x51 (~85C) Default
0x23: Internal Over Temperature Fault Threshold	0x45 (~95C) Default

Setting IOT register(s) to the minimum of 0x00 equates to an internal temperature of +151.1°C. The maximum setting of 0xFF is -63.7°C. Round the result of [Equation 13](#) to the nearest integer (max 255, min 0) to set the Temperature Threshold register values based on the desired temperature (°C).

$$(EQ. 13) \quad \text{RegVal} = (-2.95 \times 10^{-4}) \cdot \text{Temp}^2 - 1.15975 \cdot \text{Temp} + 182.23$$

Use [Equation 14](#) to convert these two threshold register values (or the internal temperature register value) read from the ISL94216 to temperature in °C.

$$(EQ. 14) \quad \text{TempThreshold} = (-1.82 \times 10^{-4}) \cdot \text{RegVal}^2 - 0.79605 \cdot \text{RegVal} + 151.11$$

### 5.9.2 0x5E Internal Temperature (R)

The Internal Temperature register reports the internal temperature of the ISL94216 based on an internal Negative Temperature Coefficient (NTC) temperature sensing circuit. As the internal temperature increases the voltage across the element decreases.

Use [Equation 15](#) to calculate the internal temperature in °C directly from the register decimal value:

$$(EQ. 15) \quad \text{IT}_C = (-1.82 \times 10^{-4}) \cdot (\text{RegVal}^2) - 0.79605 \cdot (\text{RegVal}) + 151.11$$

### 5.10 Regulator Measurements and Detectors

The regulator and voltage reference blocks with a typical external component configuration is illustrated in [Figure 91](#). The external component configuration is detailed in [Figure 100 on page 93](#).

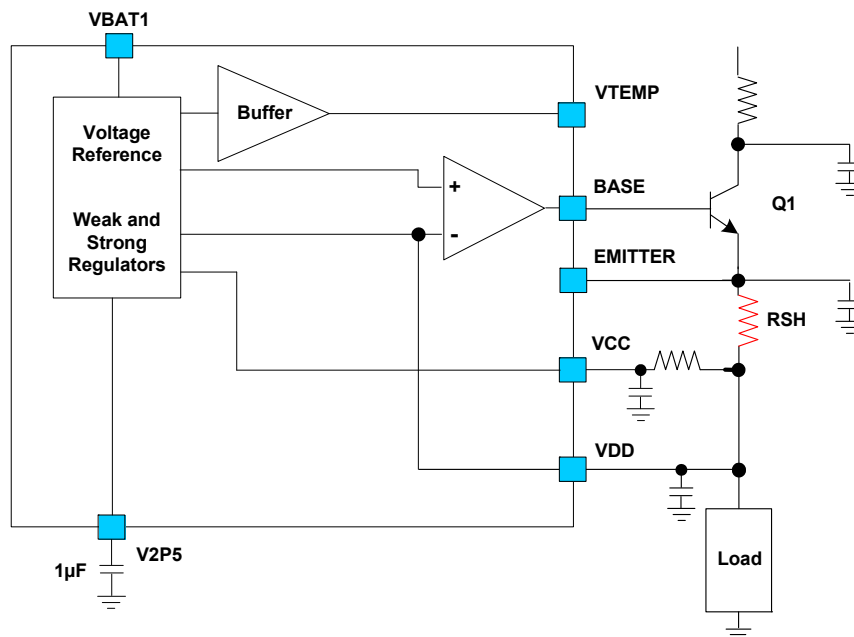

**Figure 91. Regulator and Reference**

The VBAT1 pin connects to internal regulators that have low current sourcing capabilities. Their purpose is to power up essential circuitry when the part starts up or is in LOW POWER or SHIP mode (with bit [“0x1B.1 LP REG” on page 64](#) set to “0”).

The VCC pin is the analog power input of the device while the VDD pin is the digital power input. The VCC, VDD, and V2P5 pins have window comparators that monitor the voltages. If their respective voltages are outside the  $PG_{VCC}$ ,  $PG_{VDD}$ , or  $PG_{2p5v}$  (page 16) windows for 1ms, the device transitions to SHIP mode.

ADC multiplexer inputs (not shown) are connected to the VTEMP and VCC pins of the device. Voltage measurement of the these pins tests the health of the regulators and loads. The Emitter to VDD pin voltage is also measured by the ADC and is stored in register "[0x61-62 IREG Voltage \(R\)](#)" on page 66. This voltage can be used to calculate the NPN emitter current.

The amplifier driving the BASE pin sources a minimum of 1mA over the operating temperature range. This corresponds to a maximum regulation current of around 100mA assuming a minimum NPN  $\beta$  of 100.

### 5.10.1 0x1B V<sub>REG</sub> Operation

The V<sub>REG</sub> Operation register holds settings for Communications Timeout, "Other" scan and load detect delays, regulator operation in LOW POWER and SHIP Modes and the V<sub>REG</sub> measurement Trigger.

**Table 34. 0x1B V<sub>REG</sub> Operation Register**

Bits	D[7:6]	D[5:4]	D[3:2]	D[1]	D[0]
Bit Name	Communications Timeout	Update Other	LD Delay	LP REG	V <sub>REG</sub> Trig
Default	11	11	00	0	0

#### 5.10.1.1 0x1B.7:6 Communications Timeout

The Communications Timeout bits set the timeout period if bit "[0x1F.1 Communication Timeout EN](#)" on page 67 is set ("1") to enable the timer. The Communication Timeout Enable bit enables the  $t_{COM}$  (page 17) timer that transitions the part from either SCAN or IDLE to LOW POWER Mode if no communications have been received in the selected time. The timeout setting is ignored if the Communication Timeout Enable bit is clear ("0"), disabling this feature and preventing the automatic mode transition.

**Table 35. Timeout Selections**

D[7:6]	Communications Timeout
00	128ms
01	512ms
10	2.048s
11	4.096s

#### 5.10.1.2 0x1B.5:4 Update Other

The Update Other bits set the number of System Scans required before ETAUX,  $V_{BAT1}$ ,  $V_{VCC}$ ,  $I_{REG}$ ,  $V_{TEMP}$ , and Internal Temperature (IT) measurements are made in SCAN mode as part of continuous scans. Setting "00" enables an update on every System Scan while the other settings enable an update at other frequencies. This setting is ignored during single triggered scans.

**Table 36. Update Other Bits**

D[5:4]	Update Other Number of System Scans
00	1 (Update on every scan)
01	8 (Update on scan 1, 9, 17, 25...)
10	16 (Update on scan 1, 17, 33, 49...)
11	64 (Update on scan 1, 65, 129...)

### 5.10.1.3 0x1B.3:2 LD Delay

The Load Detect time Delay bits set a time delay in addition to  $t_{LDEN}$  (page 15) before testing for a load. Available settings for the LD Delay bits are listed in Table 37. See “Short-Circuit Detection and Recovery” on page 50, “Load Detection” on page 54, and “LDMON Pin (49)” on page 96 for more information about load detection.

**Table 37. Load Detect Time Delay**

D[3:2]		LD Delay (s)
0	0	0.25
0	1	1
1	0	2
1	1	4

### 5.10.1.4 0x1B.1 LP REG

The Low Power Regulator bit selects which regulator is on between sets of measurements during LOW POWER mode (measurements are not executed in SHIP mode). For the lowest power consumption in LOW POWER and SHIP Modes, set this bit to “0” (default, “Weak” regulator). This setting cannot power external circuitry in LOW POWER and SHIP Modes. A setting of “1” selects the “Strong” regulator that uses the external NPN transistor which can power external circuitry in both LOW POWER and SHIP Modes.

### 5.10.1.5 0x1B.0 V<sub>REG</sub> Trigger

A “0” to “1” transition of this bit in IDLE mode starts measurement of  $V_{VCC}$ ,  $V_{VTEMP}$ , and  $I_{REG}$ . When received, the Busy bit transitions from “0” to “1”, and the Trigger bit clears. The Busy bit remains set until the action is completed, and then returns to “0”.

After measurement, the voltages are compared to the relevant threshold registers. See “0x60 V<sub>VCC</sub> Voltage (R)” on page 65, “0x5F V<sub>VTEMP</sub> Voltage (R)” on page 65, and “0x61-62 I<sub>REG</sub> Voltage (R)” on page 66 for details.

This trigger bit is ignored in SHIP and LOW POWER Modes and can trigger sequences in IDLE or SCAN mode only. This trigger should be used in IDLE mode because Renesas recommends to reserve SCAN mode for System Scans only.

## 5.10.2 0x1C V<sub>VCC</sub> Min Threshold

The  $V_{VCC}$  Minimum Threshold register sets the comparator threshold for the VCC voltage measurement. After a VCC measurement, this threshold voltage is compared to the measurement result stored at “0x60 V<sub>VCC</sub> Voltage (R)” on page 65. If the VCC voltage is less than or equal to the threshold, fault bit “0x63.7 VCCF” on page 79 is set. This fault sets ALRT low if mask bit 0x83.7 is “0” (see “0x83 Priority Fault Mask” on page 81). Table 38 shows the format of this register.

**Table 38. 0x1C V<sub>VCC</sub> Min Threshold Register**

Bits	D[7:0]
Bit Name	VCCMIN
Default	0000 0000
$V_{VCCStep}$	25.104mV

$$(EQ. 16) \quad V_{Threshold} = (RegVal) \cdot V_{VCCStep} + 0.5 \cdot V_{VCCStep}$$

Multiply the register value by the step size  $V_{VCCStep}$  and add the  $\frac{1}{2}$  LSB offset to calculate the threshold value (Equation 16). The register supports settings from 12.55 $\mu$ V to 6.414V.



### 5.10.3 0x1D,1E IREG<sub>OC1,2</sub> Threshold

The Regulator Overcurrent Charge Threshold registers set the digital comparator overcurrent threshold for the EMITTER to VDD measurement. IREG<sub>OC1</sub> is the limit that the I<sub>REG</sub> Voltage reading is compared to while the device is in SCAN or IDLE mode. IREG<sub>OC2</sub> is the limit that the reading is compared to while the device is in LOW POWER mode. After an I<sub>REG</sub> measurement, the threshold voltage is compared to the measurement result stored at [“0x61-62 IREG Voltage \(R\)” on page 66](#). If the I<sub>REG</sub> measurement is greater than the threshold, the appropriate fault bit is set based on mode.

If the IREG<sub>OC1</sub> threshold comparison fails, the IREG1 fault bit [“0x67.2 IREG1” on page 88](#) is set to “1” (applies in SCAN or IDLE modes). This fault sets ALRT low if mask bit 0x87.2 is set to “0” (see [“0x87 Status Mask” on page 88](#)).

If the IREG<sub>OC2</sub> threshold comparison fails, the IREG2 fault bit [“0x67.1 IREG2” on page 88](#) is set to “1” (applies in LOW POWER mode). This fault sets ALRT low if mask bit 0x87.1 is set to “0” (see [“0x87 Status Mask” on page 88](#)).

**Table 39. 0x1D IREG<sub>OC1</sub> and 0x1E IREG<sub>OC2</sub> Threshold Registers**

Address - Bits	0x1D - D[7:0]	0x1E - D[7:0]
Name	IREG <sub>OC1</sub>	IREG <sub>OC2</sub>
Default	1111 1111	1111 1111
IREGOC <sub>Step</sub>	1.345mV	
Offset	1.3396mV	

$$(EQ. 17) \quad V_{\text{Threshold}} = (\text{RegVal}) \cdot \text{IREGOC}_{\text{Step}} + \text{Offset}$$

Multiply the register value by the step size IREGOC<sub>Step</sub> and add the fixed offset from [Table 39](#) to calculate the threshold ([Equation 17](#)). The registers support settings from 1.34mV to 344.28mV.

### 5.10.4 0x5F V<sub>VTEMP</sub> Voltage (R)

The V<sub>VTEMP</sub> Voltage register stores the result from the measurement of the V<sub>TEMP</sub> pin voltage, which is included in the group of measurements done in LOW POWER mode, in any System Scan, and in the group of measurements triggered with [“0x1B.0 V<sub>REG</sub> Trigger” on page 64](#) in IDLE mode. The VTEMP reference voltage powers the external thermistors. After measurement, the voltage is compared to the threshold VTEMP<sub>Min</sub> (1.1V typical, [page 16](#)). If the voltage is less than or equal to the threshold, fault bit [“0x67.0 VTMPF” on page 88](#) is set. This fault can set ALRT low if mask bit 0x87.0 is set to 0 (see [“0x87 Status Mask” on page 88](#)).

**Table 40. 0x5F V<sub>VTEMP</sub> Voltage**

Bits	D[7:0]
Default	0000 0000
V <sub>VTEMPStep</sub>	3.138mV
Offset	804.908mV

$$(EQ. 18) \quad V_{\text{VTEMP}} = (\text{RegVal}) \cdot V_{\text{VTEMPStep}} + \text{Offset}$$

Multiply the register value by the step size V<sub>VTEMPStep</sub>, and add the fixed offset (minimum value of the V<sub>VTEMP</sub> range) to calculate the voltage [Equation 18](#). The register records results from 804mV to 1.605V.

### 5.10.5 0x60 V<sub>VCC</sub> Voltage (R)

The V<sub>VCC</sub> Voltage register stores the result from the internal measurement of the VCC pin voltage. The voltage measurement is compared to the threshold register [“0x1C VVCC Min Threshold” on page 64](#). If the comparison

fails, the fault bit “[0x63.7 VCCF](#)” on page 79 is set. This fault sets  $\overline{\text{ALRT}}$  low if the mask bit 0x83.7 is set to “0” (see “[0x83 Priority Fault Mask](#)” on page 81).

**Table 41. 0x60 V<sub>VCC</sub> Voltage**

Bits	D[7:0]
Default	0000 0000
V <sub>VCCStep</sub>	25.104mV

$$(EQ. 19) \quad V_{VCC} = (\text{RegVal}) \cdot V_{VCCStep} + 0.5 \cdot V_{VCCStep}$$

Multiply the register value by the step size V<sub>VCCStep</sub> ([Table 41](#)) and add the ½ LSB offset to calculate the voltage ([Equation 19](#)). The register records results from 12.55mV to 6.414V.

### 5.10.6 0x61-62 I<sub>REG</sub> Voltage (R)

The read only I<sub>REG</sub> registers contain the 16-bit result of the measurement of the voltage across the sense resistor between the EMITTER and VDD pins. After measurement, the voltage is compared to the 0x1D IREG<sub>OC1</sub> threshold register in SCAN or IDLE modes or the 0x1E IREG<sub>OC2</sub> threshold register if in LOW POWER mode (see “[0x1D.1E IREG<sub>OC1, 2</sub> Threshold](#)” on page 65). If the 0x1D IREG<sub>OC1</sub> comparison fails, the fault bit “[0x67.2 IREG1](#)” on page 88 is set. If the 0x1E IREG<sub>OC2</sub> comparison fails, the fault bit “[0x67.1 IREG2](#)” on page 88 is set. These faults set  $\overline{\text{ALRT}}$  low if mask bits IREG1 and IREG2 are “0” (see “[0x87 Status Mask](#)” on page 88).

**Table 42. 0x61-62 I<sub>REG</sub> Voltage**

Address - Bits	0x61 - D[7:0]	0x62 - D[7:0]
Byte Order	MSB	LSB
I <sub>REGStep</sub>	10.507μV	

$$(EQ. 20) \quad V_{IREG} = (\text{RegVal}) \cdot I_{REGStep} + 0.5 \cdot I_{REGStep}$$

Multiply the 16-bit register value by the step size I<sub>REGStep</sub> and add the ½ LSB offset to calculate the voltage ([Equation 20](#)); next, divide by the sense resistor value to calculate the current. The register records results from 5.25μV to 344.28V.

## 5.11 V<sub>BAT1</sub>

### 5.11.1 0x1F V<sub>BAT1</sub> Operation

The V<sub>BAT1</sub> Operation register is used to enable and/or trigger measurement of V<sub>BAT1</sub> and I<sub>TEMP</sub>. It also controls averaging for these and regulator measurements.

**Table 43. 0x1F V<sub>BAT1</sub> Operation Register**

Bits	D[7]	D[6]	D[5]	D[4:2]	D[1]	D[0]
Bit Name	V <sub>BAT1</sub> EN	I <sub>TEMP</sub> EN	I <sub>TEMP</sub> Trigger	OTHER Averages	COMM TO EN	V <sub>BAT1</sub> Trigger
Default	1	1	0	0 00	1	0

#### 5.11.1.1 0x1F.7 V<sub>BAT1</sub> EN

The V<sub>BAT1</sub> Enable bit set to “1” (default) includes V<sub>BAT1</sub> measurement during System Scans. The measurement is excluded if this bit is set to “0”. This bit has no effect on V<sub>BAT1</sub> Trigger. The result of a V<sub>BAT1</sub> voltage measurement is stored in register “[0x5C - 0x5D V<sub>BAT1</sub> Voltage \(R\)](#)” on page 69.

### 5.11.1.2 0x1F.6 I<sub>TEMP</sub> EN

The Internal Temperature Enable bit set to “1” (default) includes an internal temperature measurement during System Scans. The measurement is excluded if this bit is set to “0”. This bit has no effect on I<sub>TEMP</sub> Trigger. The result of a I<sub>TEMP</sub> voltage measurement is stored in register [“0x5E Internal Temperature \(R\)” on page 62](#).

### 5.11.1.3 0x1F.5 I<sub>TEMP</sub> Trigger

A “0” to “1” transition of this bit instructs the device to start an I<sub>TEMP</sub> measurement. When received, the Busy bit transitions from “0” to “1” and the trigger bit is cleared. The Busy bit remains set until the action is completed and then returns to a “0”.

This trigger bit is ignored in SHIP and LOW POWER Modes and can only trigger sequences in IDLE or SCAN mode. This trigger should be used in IDLE mode because Renesas recommends to reserve SCAN mode for System Scans only.

### 5.11.1.4 0x1F.4:2 Other Averages

The Other Averages bits set the number of samples averaged before passing the measurement results to the respective registers. The Other Averaging bits control averaging for [“0x5C - 0x5D VBAT1 Voltage \(R\)”](#), [“0x5F VVTEMP Voltage \(R\)”](#), [“0x60 VVCC Voltage \(R\)”](#), and [“0x61-62 IREG Voltage \(R\)”](#). [Table 44](#) lists the options for this bit.

**Table 44. Other Averages**

Other Averages: D[4:2]			Samples to Average
0	0	0	1
0	0	1	2
0	1	0	4
0	1	1	8
1	0	0	16
1	0	1	32
1	1	0	64
1	1	1	128

The conversion time for these measurements can be estimated as [Equation 21](#):

$$(EQ. 21) \quad OTHER_{CT} = (3 + \text{SamplesToAverage}) \cdot ADC_{CT2}$$

ADC<sub>CT2</sub> is the base conversion time of the ADC and can be found in the specification table on [page 17](#).

### 5.11.1.5 0x1F.1 Communication Timeout EN

The Communication Timeout Enable bit enables the t<sub>COM</sub> ([page 17](#)) timer that transitions the part from SCAN or IDLE to LOW POWER mode if no communications have been received in the selected time. Set the bit to “1” (default) to enable the timer. Set to “0” to disable this feature and prevent the automatic mode transition. See [“0x1B.7:6 Communications Timeout” on page 63](#) for the timer settings available.

### 5.11.1.6 0x1F.0 V<sub>BAT1</sub> Trigger

A “0” to “1” transition of this bit instructs the device to start a V<sub>BAT1</sub> measurement. When received, the Busy bit transitions from “0” to “1” and the trigger bit is cleared. The Busy bit remains set until the action is completed and returns to “0”.

This trigger bit is ignored in SHIP and LOW POWER Modes and can trigger sequences in IDLE or SCAN mode only. This trigger should be used in IDLE mode because Renesas recommends to reserve SCAN mode for System Scans only.

### 5.11.2 0x20 - 0x21 V<sub>BAT1</sub> Thresholds

The V<sub>BAT1</sub> Threshold registers set the upper and lower voltage thresholds that are compared to V<sub>BAT1</sub> measurements. A violation of these thresholds may result in a disconnection of the power FETs. See [“0x24.3 VBAT1CON” on page 71](#). The simplified block diagram of the V<sub>BAT1</sub> fault detection functions is illustrated in [Figure 92](#).

The [“0x09.5 Other Fault Delay” on page 48](#) counters are bypassed if the part is not running in continuous SCAN mode.

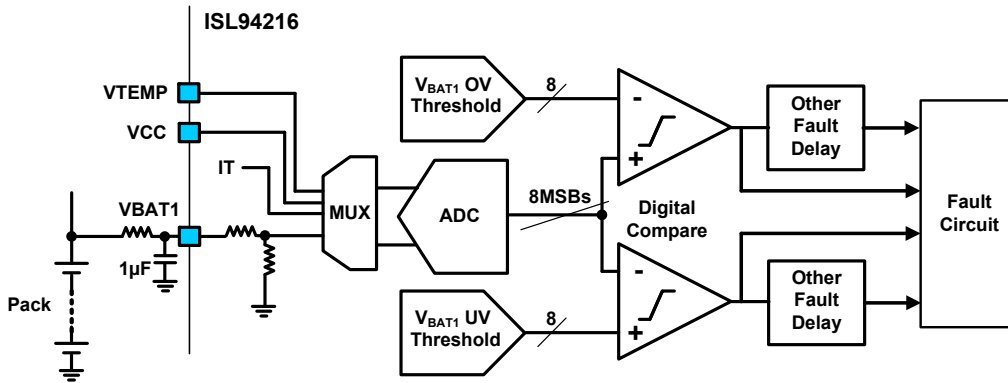

Figure 92. V<sub>BAT1</sub> OV/UV Detectors

#### 5.11.2.1 0x20 V<sub>BAT1</sub> OV Threshold

The V<sub>BAT1</sub> OV Threshold register sets the threshold voltage for the digital comparator that monitors for V<sub>BAT1</sub> overvoltage. The V<sub>BAT1</sub> overvoltage threshold register format is shown in [Table 45](#).

Table 45. 0x20 OV<sub>BAT1</sub> Threshold Register

Bits	D[7:0]
Bit Name	V <sub>BAT1</sub> OV Threshold
Default	1111 1111
V <sub>BAT1</sub> <sub>thStep</sub>	301.25mV
Offset	300.66mV

Multiply the register value by V<sub>BAT1</sub><sub>thStep</sub> and add the fixed offset to calculate the threshold ([Equation 22](#)). The register supports settings from 300.66mV to 77.12V.

$$(EQ. 22) \quad V_{Threshold} = (RegVal) \cdot V_{BAT1_{thStep}} + Offset$$

If the measured V<sub>BAT1</sub> voltage exceeds this threshold for more than [“0x09.5 Other Fault Delay” on page 48](#) Scans during charge, then the fault [“0x65.7 VBOVF” on page 83](#) is set. The Other Fault Delay counter is bypassed if the part is not running in continuous SCAN mode.

### 5.11.2.2 0x21 V<sub>BAT1</sub> UV Threshold

The V<sub>BAT1</sub> UV Threshold register sets the threshold voltage for the digital comparator that monitors for V<sub>BAT1</sub> undervoltage. The V<sub>BAT1</sub> undervoltage threshold register format is shown in [Table 46](#).

**Table 46. 0x21 UV<sub>BAT1</sub> Threshold Register**

Bits	D[7:0]
Bit Name	UVBAT1
Default	0000 0000
V <sub>BAT1</sub> <sub>thStep</sub>	301.25mV
Offset	300.66mV

Multiply the register value by V<sub>BAT1</sub><sub>thStep</sub> and add the fixed offset to calculate the threshold ([Equation 22](#)). The register supports settings from 300.66mV to 77.12V.

If the measured V<sub>BAT1</sub> voltage is less than or equal to this threshold for more than “[0x09.5 Other Fault Delay](#)” scans during discharge, then fault “[0x65.6 VBUVF](#)” is set. The Other Fault Delay counter is bypassed if the part is not running in continuous SCAN mode.

### 5.11.3 0x5C - 0x5D V<sub>BAT1</sub> Voltage (R)

The V<sub>BAT1</sub> Voltage register stores the measured value of the voltage between the V<sub>BAT1</sub> and VSS pins. The pin voltage is divided internally for measurement.

**Table 47. 0x5C-5D V<sub>BAT1</sub> Voltage**

Address - Bits	0x5C - D[7:0]	0x5D - D[7:0]
Byte Order	MSB	LSB
V <sub>BAT1</sub> <sub>Step</sub>	1.177mV	

$$(EQ. 23) \quad V_{BAT1} = (RegVal) \cdot V_{BAT1_{Step}} + 0.5 \cdot V_{BAT1_{Step}}$$

Multiply the register value by the step size V<sub>BAT1</sub><sub>Step</sub> and add the 1/2 LSB offset to calculate the voltage with [Equation 23](#). The register records results from 588μV to 77.12V.

## 5.12 Power FET Block

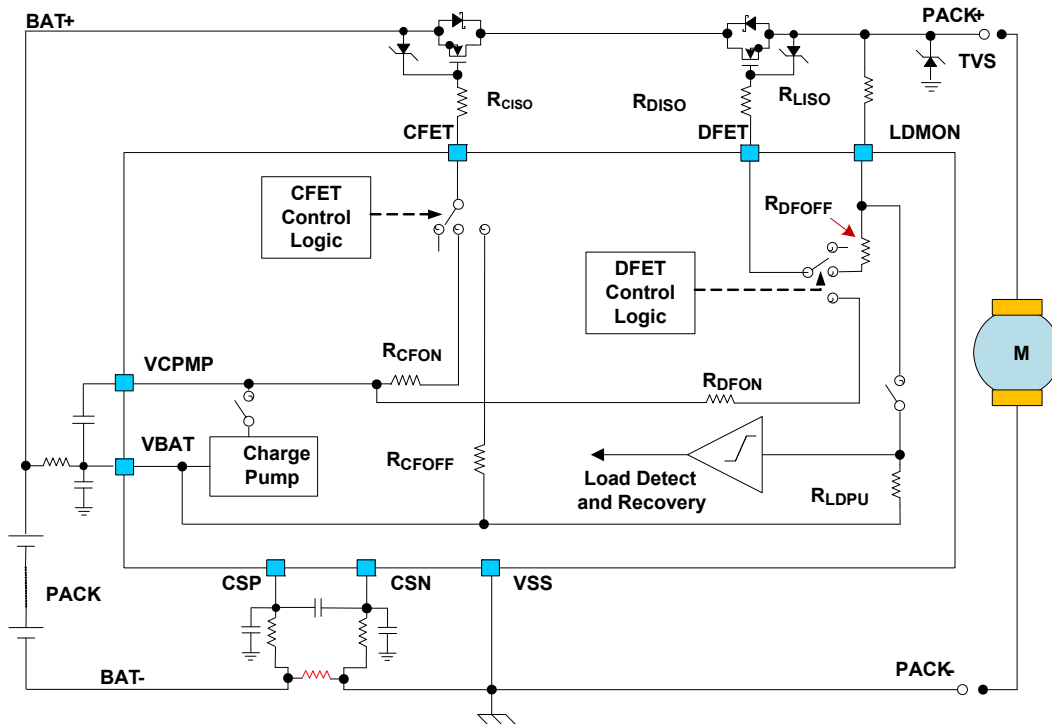

Figure 93. Block Diagram of Power FET Controls

### 5.12.1 0x24 Power FET Operation

The Power FET Operation register allows control of power FET and Open Wire functionality within the ISL94216. This includes enable/disable of the charge pump and power FETs, and whether Cell, VBAT1 or ETAUX threshold violations can disconnect power FETs. [Table 48](#) shows the format of this register.

See [“CFET and DFET Pins \(50, 51\)” on page 97](#) and [“Scan Will Not Start” on page 111](#) for details about how the Connect and Enable bits interact with fault and other control bits for FET control and System Scan.

Table 48. 0x24 Power FET Operation Register

Bits	D[7]	D[6]	D[5]	D[4]	D[3]	D[2]	D[1]	D[0]
Bit Name	CPMP EN	OW EN	OW Trigger	CELL CON	VBAT1 CON	ETA CON	DFET EN	CFET EN
Default	0	1	0	1	1	1	0	0

#### 5.12.1.1 0x24.7 CPMP EN

The Charge Pump Enable bit enables the charge pump in IDLE or SCAN Modes if set to “1”. Set the bit to “0” (default) to disable the charge pump circuitry. The charge pump provides a biasing voltage to CB16. Disabling the charge pump reduces the CB16 pin maximum voltage.

When the charge pump is enabled (in IDLE or SCAN) and its output voltage rises above  $V_{pmpMin}$  ([page 16](#)), bit CPMP NRDY is automatically cleared to “0”. If the voltage drops below  $V_{pmpFall}$  ([page 16](#)), bit [“0x65.5 CPMP NRDY” on page 83](#) is set to “1”. If CPMP EN is set to “0”, then CPMP NRDY = 0.

There is a delay of about 1ms from enabling the charge pump, and also from setting CPMP NRDY to “1” by the  $V_{pmpFall}$  comparator, before the  $V_{pmpMin}$  comparator is allowed to clear CPMP NRDY.

If enabled, the charge pump circuitry is powered down when the device transitions to LOW POWER or SHIP mode, though the setting of the CPMP EN bit is not changed. When the device transitions back to IDLE or SCAN mode, the charge pump restarts. If the CFET EN and/or DFET EN bits are “1”, then CFET and/or DFET drivers are also turned back on.

### 5.12.1.2 0x24.6 OW EN

Set the Open-Wire enable bit to “1” (default) to include an open-wire test sequence during System Scans. Set this bit to “0” to disable open-wire test during System Scans. The frequency of open-wire tests is selected by bits [“0x03.6:5 OW Update” on page 43](#).

During an open-wire test a current measurement is always performed, independent of the setting of the I<sub>PACK</sub> EN bit 0x03.7. The current measurement determines if the device is discharging while the open-wire test is being performed. The results of the VSS and VBAT open-wire tests are invalid during discharge so they are omitted.

### 5.12.1.3 0x24.5 OW Trigger

The Open-Wire Trigger bit initiates an open-wire test sequence regardless of the setting of 0x24.6 OW Enable. A “0” to “1” transition instructs the device to start an open-wire test sequence. When the open-wire test has started, the Trigger bit clears, the Busy bit is set until the test complete and then it also clears. See [“Open-Wire Function” on page 112](#) for more information.

This Trigger bit is ignored in SHIP and LOW POWER modes and can trigger sequences in IDLE or SCAN mode only. This trigger should be used in IDLE mode because Renesas recommends to reserve SCAN mode for System Scans only.

The Open-Wire test sequence does not check the ETAUX pins; these must be checked separately. See [“Aux Pins Open-Wire Test” on page 93](#) for details.

### 5.12.1.4 0x24.4 CELLCON

The V<sub>CELL</sub> Connect bit connects the outputs of the Delta V<sub>Cell</sub>, UV and OV comparators from a V<sub>CELL</sub> scan to the FET control block. If any of the cell voltage OV, UV, or delta V<sub>CELL</sub> max thresholds are violated (see [“0x06 - 0x07 VCELL OV/UV Threshold”](#) and [“0x08 V<sub>CELL</sub> Max Delta Threshold”](#)), the CFET and/or DFET may be turned off per the setting of [“0x0E.3 CPWR” on page 53](#). A “1” (default) connects the V<sub>CELL</sub> fault outputs to the FET controller. Setting this bit to “0” moves fault handling responsibility to the MCU as these faults do not disconnect the power FET(s).

Continuous scans are halted on detection of these faults regardless of the setting of V<sub>CELL</sub> Connect. See [“CFET and DFET Pins \(50, 51\)” on page 97](#) and [“Scan Will Not Start” on page 111](#) for details on fault reaction.

### 5.12.1.5 0x24.3 VBAT1CON

The V<sub>BAT1</sub> Connect bit connects the results from the V<sub>BAT1</sub> comparison bits to the FET control block. A “1” (default) connects the V<sub>BAT1</sub> fault outputs to the FET controller.

If the measurement result for V<sub>BAT1</sub> ([“0x5C - 0x5D VBAT1 Voltage \(R\)”](#)) exceeds the OV threshold at 0x20 ([“0x20 - 0x21 VBAT1 Thresholds”](#)) when bit [“0x0E.3 CPWR”](#) is set to “0”, then both CFET and DFET are shut off and System Scan is stopped.

- If CPWR is set to “1” and [“0x67.6 CHRGI” on page 87](#) is “1”, then a V<sub>BAT1</sub> OV shuts off CFET.
- If CPWR is set to “1” and [“0x67.7 DCHRGI” on page 87](#) is “1”, then a V<sub>BAT1</sub> UV shuts off DFET

Setting the VBAT1CON bit to “0” moves fault handling responsibility to the MCU because failing results from V<sub>BAT1</sub> threshold comparisons do not disconnect the Power FET(s), though continuous scans are halted.

### 5.12.1.6 0x24.2 ETA Connect

The External Temperature and Auxiliary Port Connect bit connects the results from the ETAUX comparison bits to the FET Control block. A “1” (default) connects the ETAUX fault outputs to the FET Controller.

If the measurement result for either the xT0 or xT1 voltage exceeds the related CUT threshold at 0x13 or 0x17 while CHRGI is “1” and CPWR is “0”, the power FETs are disconnected and System Scan is stopped. If the CPWR bit is “1”, in this case only, CFET is shut off.

If the measurement result for either the xT0 or xT1 voltage exceeds the related DUT threshold at 0x15 or 0x19 while DCHRGI is “1” and CPWR is “0”, the power FETs are disconnected and System Scan is stopped. If the CPWR bit is “1”, in this case only, DFET is shut off.

If the measurement result for either the xT0 or xT1 voltage drops below either the COT threshold at 0x14 or 0x18 while CHRGI is “1” and CPWR is “0”, the power FETs are disconnected and System Scan is stopped. If the CPWR bit is “1”, in this case only, CFET is shut off.

If the measurement result for either the xT0 or xT1 voltage drops below either the DOT threshold at 0x16 or 0x1A while DCHRG1 is “1”, and CPWR is “0”, the power FETs are disconnected and System Scan is stopped. If the CPWR bit is “1”, in this case only, DFET is shut off.

Setting the External Temperature and Auxiliary Port Connect bit to “0” moves fault handling responsibility to the MCU since these faults do not disconnect the power FET(s), though continuous scans are halted.

See the following sections for more information: [“ETAUX Detectors”](#), [“0x13-1A ETAUX Thresholds”](#), [“0x67.6 CHRGI”](#), [“0x67.7 DCHRG1”](#), and [“0x0E.3 CPWR”](#).

#### 5.12.1.7 0x24.1 DFET EN

The DFET enable bit turns the DFET ON and OFF. A “1” activates the DFET unless prevented by a related fault. The default value of “0” disables the DFET. The DFET cannot be enabled when the chip is being reset, or if it is in LOW POWER or SHIP Modes. In the case of some faults, writing this bit does not turn on the DFET until the fault is cleared. This bit does not indicate the DFET pin status if a related fault is set.

The DFET is turned off and remains off under the following conditions:

[DSCF OR IOTF OR OWF OR VCCF OR CPMP NRDY OR IREG1 OR VTMPF]  
OR

[NOT(CPWR) AND FCDC AND CHRGI AND COCF] OR [CFD AND DCHRG1 AND DOCF]

The DFET is turned off and remains off under the following conditions if bit 0x24.4 CELLCON is set:

{CPWR AND [DVCF OR UVF OR (NOT{DCHRWOV} AND OVF)]}

OR

NOT(CPWR) AND {DVCF OR [CHRG1 AND NOT(CHRWUV) OR DCHRG1] AND UVF

OR

[DCHRG1 AND NOT(DCHRWOV) OR CHRG1] AND OVF}

$V_{Cell}$  OVF does not disable DFET during discharge if bit [“0x02.6 DCHRWOV” on page 42](#) is set.

The DFET is turned off and remains off under the following conditions if bit 0x24.3 VBAT1CON is set:

[CPWR AND DCHRG1 AND VBUVF] OR [NOT(CPWR) AND CHRGI AND VBOVF]

The DFET is turned off and remains off under the following conditions if bit 0x24.2 ETAUX Connect is set:

[DCHRG1 AND (DUT0 OR DUT1 OR DOT0 OR DOT1)]

OR

[NOT(CPWR) AND CHRGI AND (CUT0 OR CUT1 OR COT0 OR COT1)]

See [“CFET and DFET Pins \(50, 51\)” on page 97](#) and [“Scan Will Not Start” on page 111](#) for details about how the Connect and Enable bits interact with fault and other control bits for FET control and System Scan.

#### 5.12.1.8 0x24.0 CFET EN

The CFET enable bit turns the CFET ON and OFF. A “1” activates the CFET unless prevented by a related fault. The default value of “0” disables the CFET. The CFET cannot be enabled when the chip is being reset, or if it is in LOW POWER or SHIP Modes. In the case of some faults, writing this bit does not turn on the CFET until the fault is cleared. This bit does not indicate status of the CFET pin if a related fault is indicated.

The CFET is turned off and remains off under the following conditions:

[DSCF OR IOTF OR OWF OR VCCF OR CPMP NRDY OR IREG1 OR VTMPF]

OR



[FCDC AND CHRGI AND COCF] OR [NOT(CPWR) AND CFD AND DCHRG AND DOCF]

The CFET is turned off and remains off under the following conditions if bit 0x24.4 CELLCON is set:

{CPWR AND [DVCF OR OVF OR (NOT{CHRWOV} AND UVF)]}

OR

NOT(CPWR) AND {DVCF OR [CHRG AND NOT(CHRWUV) OR DCHRG] AND UVF}

OR

[DCHRG AND NOT(DCHRWOV) OR CHRG] AND OVF}

$V_{Cell}$  UVF does not disable the CFET during charge if bit [“0x02.5 CHRWUV” on page 42](#) is set.

The CFET is turned off and remains off under the following conditions if bit 0x24.3 VBAT1CON is set:

{NOT(CPWR) AND [CHRG AND VBOVF OR DCHRG AND VBUVF]}

OR

[CPWR AND CHRG AND VBOVF]

The CFET is turned off and remains off under the following conditions if bit 0x24.2 ETAUX Connect is set:

[CHRG AND (CUT0 OR CUT1 OR COT0 OR COT1)]

OR

[NOT(CPWR) AND DCHRG AND (DUT0 OR DUT1 OR DOT0 OR DOT1)]

See [“CFET and DFET Pins \(50, 51\)” on page 97](#) and [“Scan Will Not Start” on page 111](#) for details about how Connect and Enable bits interact with fault and other control bits for FET control and System Scan.

## 5.13 Cell Balancing Registers

### 5.13.1 0x25 CB Operation

The CB Operation register controls cell balancing features of the ISL94216. [Table 49](#) shows the CB Operation register. Though some settings are automatically cleared on completion, Renesas recommends this register be set to default when cell balancing is not in operation.

**Table 49. 0x25 CB Operation Register**

Bits	D[7]	D[6]	D[5]	D[4]	D[3]	D[2]	D[1]	D[0]
Bit Name	CB EN	Auto CB EN	CB Config	CB TRIG	IEOC EN	CB Mask	CB EOC	CB CHRG
Default	0	0	0	0	0	0	0	1

#### 5.13.1.1 0x25.7 CB EN

Set this bit to “1” to enable cell balancing. Set this bit to “0” (default) to disable all forms of cell balancing.

#### 5.13.1.2 0x25.6 Auto CB EN

Set this bit to “1” for the ISL94216 to automatically select the cells to be balanced. If this bit is set to “0” (default) the cells to be balanced must be selected by the user in registers [“0x26-27 CB Cell State” on page 75](#).

When the bit [“0x66.7 BAT FULL” on page 85](#) is set high indicating the completion of a charging cycle, bit Auto CB EN is reset to “0”. This means the microcontroller must clear the battery-full bit before enabling Auto CB EN and the next cycle of cell balancing. See [“Automatic Cell Balancing” on page 115](#) for more information.

#### 5.13.1.3 0x25.5 CB Configuration

The CB Configuration bit sets the ISL94216 cell balance configuration to drive internal cell balancing FETs when the bit is set to “0” (default) or to drive external cell balancing FETs if set to “1”.

The internal cell balancing FETs ([Figure 94](#)) are a space saving feature ideal for low current and slow battery charging applications.

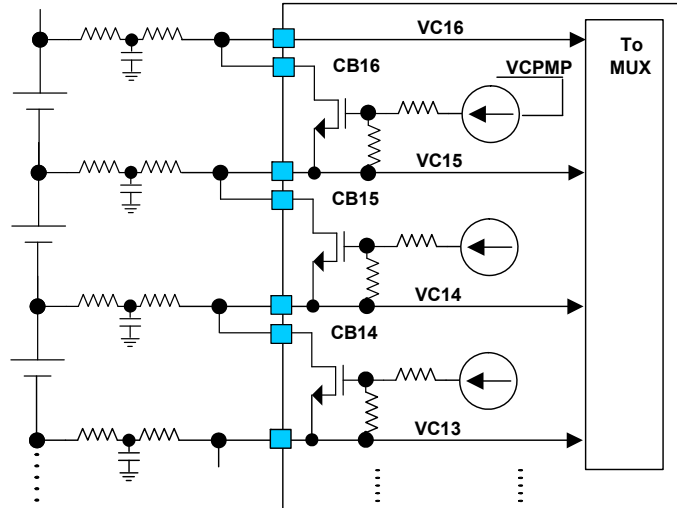

Figure 94. Internal Cell Balancing Configuration

Set the CB Config bit to “1” to configure the ISL94216 to drive external cell balancing FETs as shown in [Figure 95](#). External balancing FETs are used with large capacity and/or fast charging battery packs.

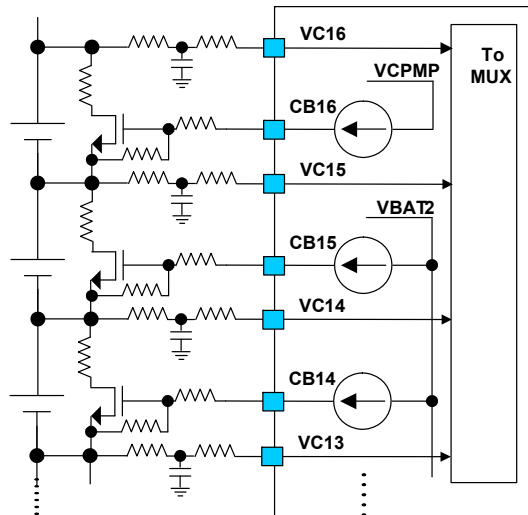

Figure 95. External Cell Balancing Configuration

**5.13.1.4 0x25.4 CB Trigger**

A “0” to “1” transition of this bit in IDLE mode triggers one Cell Balancing cycle ([Figure 96 on page 78](#)). When triggered, the Busy bit transitions from “0” to “1” and the trigger bit clears. The Busy bit remains set until the action is completed, and then returns to a “0”.

The trigger bit is ignored in SHIP and LOW POWER Modes and can only trigger sequences in IDLE or SCAN mode. This trigger should be used only in IDLE mode because Renesas recommends to reserve SCAN mode for System Scans.

**5.13.1.5 0x25.3 IEOC EN**

The Current End Of Charge Enable bit selects between ending charging when a voltage is reached or when the charge current drops below a set level. If IEOC EN is “0” (default), charging ends when any cell voltage reading is above the [“0x2D VEOC Threshold” on page 77](#), which sets bits [“0x66.4 VEOC” on page 86](#) and [“0x66.7 BAT FULL” on page 85](#), and shuts off CFET and DFET (if CPWR = 0). When IEOC EN is set to “1”, charging stops after the VEOC bit has been set (DFET shuts off if CPWR=1) and the charge current drops below the [“0x10 IEOC Threshold” on page 78](#), setting the bit [“0x66.5 IEOC” on page 86](#). This shuts off CFET and DFET (if CPWR = 0) and BAT FULL sets.

IEOC EN does not enable or disable cell balancing, but determines which cells would be balanced (if any), and how the BAT FULL bit is set. IEOC EN combined with [“0x0E.3 CPWR” on page 53](#) determines when or if DFET is shut off. The IEOC EN, CB EOC, and CB CHRГ bits select the type of cell balancing when auto cell balancing is enabled. See [“Automatic Cell Balancing” on page 115](#) for more information about the behavior of cell balancing versus these bits and related bit settings.

### 5.13.1.6 0x25.2 CB Mask

The CB Mask bit prevents adjacent cells from balancing at the same time. Balancing adjacent cells may change the amount of cell balancing current.

If the CB mask bit is “1”, the ISL94216 prevents turning on cell balancing FETs of adjacent cells at the same time. Instead, it toggles between two masks that either enable even cells or odd cells to be balanced for a period of time. For a cycle of cell balancing, each mask is applied once for CBON time before turning off cell balancing for CBOFF time (see [“0x28, 0x29 Cell Balancing Timers” on page 78](#)). The default of “0” disables the masking feature while balancing. The temperature rise of the IC due to the cell balancing FETs can be calculated using [Equation 24](#).

$$(EQ. 24) \quad \Delta T_{CB} = (\theta_{JA} \cdot n_{cbOn} \cdot I_{CB}^2 \cdot R_{cbOn})$$

$\Delta T_{CB}$  is the temperature rise of the ISL94216 due to cell balancing. Variable  $n_{cbOn}$  is the number of cells that are balancing at once,  $R_{cbOn}$  ([page 16](#)) is the cell balancing FET resistance,  $I_{CB}$  is the cell balancing current, and  $\theta_{JA}$  ([“Thermal Information” on page 13](#)) is the thermal resistivity of the ISL94216.

### 5.13.1.7 0x25.1 CB EOC

The Cell Balance End Of Charge bit is functional only when bit [“0x66.4 VEOC” on page 86](#) is set (“1”). The default CB EOC value of “0” disables cell balancing when any cell voltage reaches the setting of [“0x2D VEOC Threshold” on page 77](#). If bit CB EOC is set to “1”, cell balancing is allowed after one or more cells reach the VEOC threshold, and may continue (depending on settings and conditions) until bit [“0x66.7 BAT FULL” on page 85](#) is set. See [Table 76 on page 115](#).

The CB EOC, IEOC EN, and CB CHRГ bits select the type of auto cell balancing when cell balancing is enabled. See [“Automatic Cell Balancing” on page 115](#) for more information.

### 5.13.1.8 0x25.0 CB CHRГ

The CB Charge bit is functional only when bit [“0x66.4 VEOC” on page 86](#) is clear (“0”). When “0”, the CB CHRГ bit disables cell balancing during constant current charging while VEOC = 0. Set CB CHRГ to “1” to enable cell balancing during charging while VEOC = 0. The type of cell balancing is determined by this bit and the other control bits in this register. For more details, see [“Automatic Cell Balancing” on page 115](#).

When bit [“0x66.7 BAT FULL” on page 85](#) is set to “1”, both the Auto CB EN and CB CHRГ bits are cleared.

## 5.13.2 0x26-27 CB Cell State

The CB Cell State registers indicate the cells selected to be balanced during the next cell balancing cycle. [Table 50](#) shows the format of these registers.

**Table 50. 0x26-27 CB Cell State Register**

Address - Bits	0x26 - D[7:0]	0x27 - D[7:0]
Bit Name	CB Cells 16 to 9	CB Cells 8 to 1
Default Value	0000 0000	0000 0000

In manual mode, when [“0x25.6 Auto CB EN” on page 73](#) is set to “0”, these bits are written by the user. Setting these bits to “1” turns on the cell balancing current source or internal cell balancing FET corresponding to that bit when cell balancing is enabled and triggered.

The CB Cell State registers show the cells automatically determined by the chip to need cell balancing following the most recent set of cell voltage measurements during automatic cell balancing.

For the three cases of automatic cell balancing with IEOC EN = 1 **OR** CB EOC = 0, the chip finds the minimum of all the cell voltages and calculates the difference between each cell voltage and the minimum. For cells with a calculated difference higher than the [“0x2A CB Min Delta Threshold” on page 76](#), the CB Cell State bit is set to “1”. For other cells, it is set to “0”.

For automatic cell balancing cases with IEOC EN = 0 **AND** CB EOC = 1, the CB Cell State bit is set to “1” for cells that exceed the voltage set by the register [“0x2D VEOC Threshold” on page 77](#) minus four bits. For other cells, it is set to “0”.

These registers do not indicate that any specific cell balancing pin is active. They indicate which cells are to be balanced during the next cell balancing cycle. See [“Automatic Cell Balancing” on page 115](#) and [“Manual Cell Balancing” on page 117](#) for more details.

### 5.13.3 0x2A CB Min Delta Threshold

The Cell Balancing Minimum Delta Threshold register sets the minimum cell voltage difference that determines if a cell needs balancing. [Table 51](#) shows the format of this register.

**Table 51. 0x2A CB Min Delta Threshold Register**

Bits	D[7:0]
Byte Name	CBDMIN - Cell Balance Minimum Delta Threshold
Default	0000 0000
CBDMIN <sub>step</sub>	4.707mV
Offset	4.67mV

After a cell voltage scan has completed, the ISL94216 calculates all the differences between the lowest cell voltage and the rest of the cells in the battery pack. Under certain conditions the delta value of each cell is compared to the CBDMIN threshold to determine if the cell needs balancing for automatic cell balancing cycles. If any cell needs balancing, the bit [“0x66.0 Need CB”](#) is set to “1”. See [“0x26-27 CB Cell State”](#) for information about how this threshold is used to set those bits.

$$(EQ. 25) \quad V_{\text{Threshold}} = (\text{RegVal}) \cdot \text{CBDMIN}_{\text{Step}} + \text{Offset}$$

Multiply the register value by the step size CBDMIN<sub>step</sub> and add the fixed offset to calculate the threshold as shown in [Equation 25](#). The register supports settings from 4.67mV to 1204.97mV.

### 5.13.4 0x2B CBMAX Threshold

The Cell Balancing Maximum Threshold register sets the upper cell voltage threshold of the cell balancing range. [Table 52](#) shows the format of this register.

**Table 52. 0x2B CB Max Register**

Bits	D[7:0]
Bit Name	CBMAX - Cell Balance Overvoltage Threshold
Default	1111 1111
CBMAX <sub>step</sub>	18.828mV
Offset	18.791mV

The CBMAX register sets the threshold voltage for status bit [“0x66.2 2HI2CB” on page 86](#). After a cell voltage scan has completed, the ISL94216 compares the minimum cell voltage to the CBMAX threshold setting. If the minimum cell voltage is greater than the CBMAX value, bit 2HI2CB is set and cell balancing is blocked. Bit

2HI2CB cannot be cleared (and CB cannot restart) until the maximum measured cell voltage is below CBMAX by  $V_{CBHys}$  (page 16), which is set to  $5 \times CBMAX_{Step}$ .

$$(EQ. 26) \quad V_{Threshold} = (RegVal) \cdot CBMAX_{Step} + Offset$$

Multiply the register value by the step size  $CBMAX_{Step}$ , and add the fixed offset to calculate the threshold (Equation 26). The register supports settings from 18.791mV to 4.82V.

### 5.13.5 0x2C CBMIN Threshold

The Cell Balancing Minimum Threshold register sets the lower cell voltage threshold of the cell balancing range. Table 53 shows the format of this register.

**Table 53. 0x2C CB Minimum Register**

Bits	D[7:0]
Bit Name	CBMIN Cell Balance Undervoltage Threshold
Default	0000 0000
$CBMIN_{step}$	18.828mV
Offset	36.774 $\mu$ V

The CBMIN register sets the threshold voltage for status bit “0x66.1 2LO2CB” on page 86. After a cell voltage scan has completed, the ISL94216 compares the maximum cell voltage to the CBMIN threshold setting. If the maximum cell voltage is less than the CBMIN value, bit 2LO2CB is set and cell balancing is blocked. Bit 2LO2CB cannot be cleared (and CB cannot restart) until the minimum measured cell voltage is above CBMIN by  $V_{CBHys}$  (page 16), which is set to  $5 \times CBMIN_{step}$ .

$$(EQ. 27) \quad V_{Threshold} = (RegVal) \cdot CBMIN_{Step} + Offset$$

Multiply the register value by the step size  $CBMIN_{step}$ , and add the fixed offset to calculate the threshold (Equation 27). The register supports settings from 36.77 $\mu$ V to 4801.25mV.

### 5.13.6 0x2D VEOC Threshold

The Voltage End of Charge Threshold register sets the cell voltage used to set the status bit “0x66.4 VEOC” on page 86, which in some cases ends charging by shutting off one or both power FETs. The VEOC status bit can be used by the microcontroller to signal a charger to switch from constant current to constant voltage. See “Automatic Cell Balancing” on page 115 for the options and actions that follow VEOC. Table 54 on page 77 shows the format and default value of the VEOC Threshold register.

**Table 54. 0x2D VEOC Threshold Register**

Bits	D[7:0]
Bit Name	VEOC - Voltage End of Charge Threshold
Default	1111 1111
$VEOC_{step}$	18.828mV
Offset	18.791mV

The VEOC status bit can be cleared when all measured cell voltages are below the VEOC threshold and the user writes a “0” to it, or a “1” to the “0x02.1 Clear Faults and Status” on page 43.

$$(EQ. 28) \quad V_{Threshold} = (RegVal) \cdot VEOC_{Step} + Offset$$

Multiply the register value by the step size  $VEOC_{Step}$  and add the fixed offset to calculate the threshold (Equation 28). The register supports settings from 18.79mV to 4.82V.

This threshold comparison is not dependent on DCHRG1 or CHRGI. If a cell voltage remains above the VEOC Threshold at the completion of a charge cycle in some cases it may be necessary to increase this threshold to allow turn on of DFET.

### 5.13.7 0x10 IEOC Threshold

The Current End Of Charge Threshold register sets the minimum charge current by setting the threshold voltage of a digital comparator for undercurrent detection. This feature is used when bit “0x25.3 IEOC EN” on page 74 is “1”. The bit “0x66.5 IEOC” on page 86 is set to indicate an end of charge condition when the charge current decreases to the point at which the voltage across the current sense resistor is less than this threshold setting while CFET is “On”. Table 55 shows the format and default value of the IEOC Threshold register.

**Table 55. 0x10 IEOC Threshold Register**

Bits	D[7:0]
Bit Name	IEOC - End of Charge Current Threshold
Default	0000 0000
IEOC <sub>step</sub>	1.345mV
Offset	5.253μV

To calculate the voltage threshold, multiply the register value by the step size IEOC<sub>Step</sub> and add the fixed offset as in Equation 29. Divide the voltage threshold by the sense resistor value to calculate the threshold current setting.

$$(EQ. 29) \quad V_{Threshold} = (RegVal) \cdot IEOC_{Step} + Offset$$

The register supports settings from 5.25μV to 342.95mV.

### 5.13.8 0x28, 0x29 Cell Balancing Timers

The Cell Balancing Timer registers set the time the cell balancing circuitry is on and off. The operation of these timers is shown above in Figure 96, an example of Automatic Cell Balancing as part of a System Scan or started by “0x25.4 CB Trigger” on page 74. If part of a System Scan “Return” refers to the next step in the sequence as shown in Figure 106 on page 105, otherwise the device waits for the next trigger.

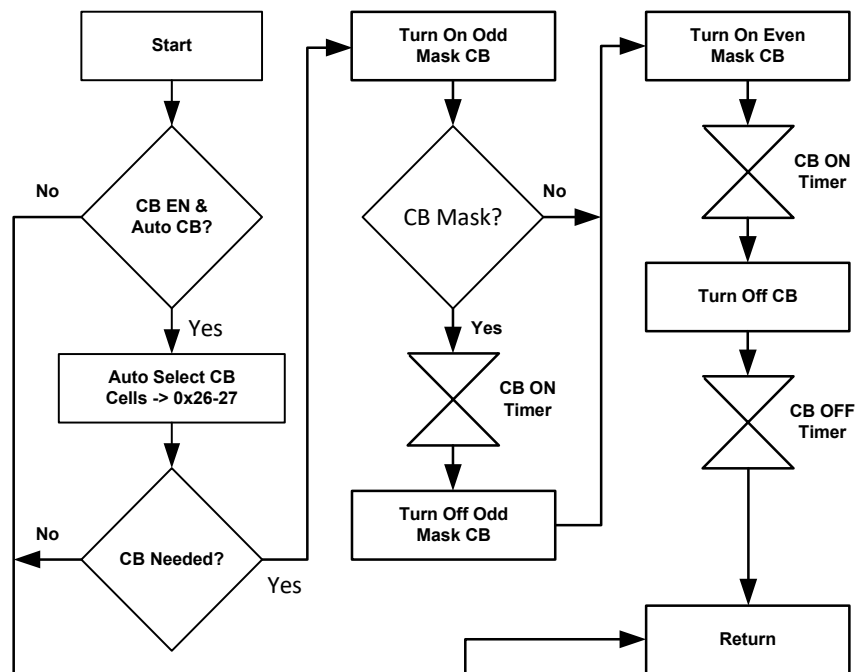

**Figure 96. Simplified Auto CB Sequence**

### 5.13.8.1 0x28 CBON

The Cell Balancing On Timer bits and the Cell Balancing On Timer Unit bit of the CBON Timer register controls the amount of time the cells are balanced during each cycle. When the timer expires, the cell balancing circuitry is turned off. [Table 56](#) shows the options for the CBON bits.

**Table 56. 0x28 CBON Bits**

CBON Timer D[7:1]	D[0]	CB ON Unit
0000 000 (0 to 1016)	0	ms
0000 000 (0 to 1016)	1	s

The step size of the setting is 8. Multiply the unit value by the step size and the 7-bit register value to calculate the CBON time setting. The timing magnitude is set by configuring the CBON Unit bit to either seconds or ms.

### 5.13.8.2 0x29 CBOFF

The Cell Balancing Off Timer bits and the Cell Balancing Off Timer Unit bit of the CBOFF Timer register controls the amount time that cell balancing is off before the timer controlled by [“0x2E.2:0 Scan Delay” on page 101](#) starts. The next continuous scan begins after the Scan Delay timer expires. If in SCAN mode following a triggered single scan the device waits for the next trigger. [Table 57](#) shows the options for the CBOFF bits.

**Table 57. 0x29 CBOFF Bits**

CBOFF Timer D[7:1]	D[0]	CBOFF Unit D[0]
0000 000 (0 to 1016)	0	ms
0000 000 (0 to 1016)	1	s

The step size of the setting is 8. Multiply the unit value by the step size and the 7-bit register value to calculate the CBOFF time setting. The timing magnitude is set by configuring the CBOFF Unit bit to either seconds or milliseconds.

## 5.14 System Faults and Status

### 5.14.1 0x63 Priority Fault

The Priority Fault register reports failures related to the battery pack. All bits in this register are latched high and can be cleared by writing a “0” to them, a chip RESET or by writing a “1” to the Clear Faults and Indicators bit (0x02.1). They cannot be cleared by writing a “0” while the condition that sets them HIGH is present. The bit locations in this register are shown in [Table 58](#). The Priority Fault Mask at address 0x83 ([page 81](#)) can be used to mask bits within this register to prevent the fault from propagating to ALRT.

**Table 58. 0x63 Priority Fault Register**

Bits	D[7]	D[6]	D[5]	D[4]	D[3]	D[2]	D[1]	D[0]
Bit Name	VCCF	OWF	IOTF	COCF	DOCF	DSCF	UVF	OVF
Default	0	0	0	0	0	0	0	0

#### 5.14.1.1 0x63.7 VCCF

The V<sub>CC</sub> Fault bit of the Priority Fault register reports an undervoltage event at the VCC pin. The bit is set when the measured voltage is below the setting of register [“0x1C VVCC Min Threshold” on page 64](#).

In SCAN mode, setting VCCF requires three consecutive results below the minimum voltage threshold if [“0x09.5 Other Fault Delay” on page 48](#) is set to “1” and a continuous System Scan is running.

This bit shuts off both CFET and DFET and stops System Scan. If unmasked by setting bit 0x83.7 to “0”, this bit also sets ALRT low.



### 5.14.1.2 0x63.6 OWF

The Open-Wire Fault of the Priority Fault register “ORs” the open-wire faults from each cell,  $V_{BAT1}$ , VSS, xT0, and xT1 pin. A “1” indicates a failure has occurred. This bit shuts off both CFET and DFET and stops System Scan. This bit also sets  $\overline{ALRT}$  low if unmasked by setting bit 0x83.6 to “0” (see [“0x83 Priority Fault Mask” on page 81](#)).

### 5.14.1.3 0x63.5 IOTF

The Internal Over-Temperature Fault reports if an over-temperature fault detection by the internal temperature sensor has occurred. The bit is set if the internal temperature is above (voltage is below) the IOTF threshold (see [“0x22 - 0x23 IOTW and IOTF Thresholds” on page 61](#)).

In SCAN mode, setting IOTF requires three consecutive results below the voltage threshold (NTC Temp Sensor) if [“0x09.5 Other Fault Delay” on page 48](#) is set to “1” and a continuous System Scan is running.

This bit shuts off both CFET and DFET and stops System Scan. If unmasked by setting bit 0x83.5 to “0”, this bit also sets  $\overline{ALRT}$  low.

### 5.14.1.4 0x63.4 COCF

The Charge Overcurrent Fault bit reports the result of the charge overcurrent comparison. If the voltage reading is above the [“0x0F COC Threshold” on page 55](#), then this bit is set to “1”, otherwise the bit remains at the default of “0”. If unmasked by setting mask bit 0x83.4 to “0”, then this bit also sets  $\overline{ALRT}$  low.

In SCAN mode, setting COCF requires a number of consecutive results, set in register [“0x0D.3:0 COCD” on page 52](#), above the overcurrent threshold while a continuous System Scan is running.

This bit shuts off CFET if the following conditions are true: the device detects charging current ( $I_{PACK} > 19$  decimal), the CPWR bit is “1” for parallel FETs ([“0x0E.3 CPWR” on page 53](#)), and the FCDC bit is “1” ([“0x0E.2 FCDC” on page 53](#)).

This bit shuts off CFET and DFET and stops System Scans if the following is true; the device detects charging current ( $I_{PACK} > 19$  decimal), CPWR bit is “0” for series FETs ([0x0E.3 on page 53](#)) and FCDC bit is “1” ([0x0E.2 on page 53](#)).

If FCDC is “0” a COCF will not shut off CFET or DFET but will stop continuous scans.

### 5.14.1.5 0x63.3 DOCF

The Discharge Overcurrent Fault bit reports the result of the discharge overcurrent comparison. If the voltage reading is below the [“0x0B DOC Threshold” on page 50](#), then this bit is set to “1”. If unmasked by setting mask bit 0x83.3 to “0”, then this bit also sets  $\overline{ALRT}$  low.

In SCAN mode, setting DOCF requires a number of consecutive results, set in register [“0x0D.7:4 DOCD” on page 52](#), below the overcurrent threshold and a continuous System Scan is running.

This bit shuts off DFET if the following is true; the device detects discharge current ( $I_{PACK} < -20$  decimal), CPWR bit is “1” for parallel FETs ([“0x0E.3 CPWR” on page 53](#)) and CFD bit is “1” ([“0x0E.7 CFD” on page 52](#)).

This bit shuts off CFET and DFET and stops System Scans if the following is true; the device detects discharge current ( $I_{PACK} < -20$  decimal), CPWR bit is “0” for series FETs ([0x0E.3 on page 53](#)) and CFD bit is “1” ([0x0E.7 on page 52](#)).

If the CFD bit is “0” a DOCF does not shut off either CFET or DFET but does stop continuous scan. This setting disconnects this fault detection from FET and scan control.

### 5.14.1.6 0x63.2 DSCF

The Discharge Short-Circuit Fault bit reports the result of the analog discharge short-circuit comparison. If the current sense voltage is more negative than [“0x0A DSC Threshold”](#) for the time set by [“0x0C DSC Delay”](#), then the bit is set to “1”.

When set, this bit shuts off both CFET and DFET and stops System Scan, and triggers a transition to IDLE mode. If unmasked by setting mask bit 0x83.2 to “0”, it also sets  $\overline{ALRT}$  low.



If bit [“0x0E.4 ELR”](#) is enabled when a DSCF occurs, and the load recovery function determines the load was removed, then the DSCF bit is automatically cleared. See [“Short-Circuit Detection and Recovery”](#). This function does not re-enable CFET or DFET.

#### 5.14.1.7 0x63.1 UVF

The Undervoltage Fault bit reports a fault if one or more of the cell voltages is below the undervoltage threshold (UV) set in register 0x07 ([“0x06 - 0x07 VCELL OV/UV Threshold”](#)). A “1” indicates a UV fault.

In SCAN mode, setting UVF requires a number of consecutive results, set in register [“0x09.3:0 V<sub>CELL</sub> Fault Delay”](#), below the undervoltage threshold while a continuous System Scan is running.

See [“0x24.1 DFET EN”](#) and [“0x24.0 CFET EN”](#) for the settings that allow this fault to shut off CFET and/or DFET respectively. See [“Scan Will Not Start” on page 111](#) for conditions where this bit stops and prevents start of System Scans.

If unmasked by setting mask bit 0x83.1 to “0”, this bit also sets  $\overline{\text{ALRT}}$  low.

#### 5.14.1.8 0x63.0 OVf

The Overvoltage Fault bit reports a fault if one or more of the cell voltage readings is above the overvoltage threshold (OV) set in register 0x06 ([“0x06 - 0x07 VCELL OV/UV Threshold”](#)). A “1” indicates an OV fault.

In SCAN mode, setting OVf requires a number of consecutive results, set in register [“0x09.3:0 V<sub>CELL</sub> Fault Delay”](#), above the overvoltage threshold while a continuous System Scan is running.

See [“0x24.1 DFET EN”](#) and [“0x24.0 CFET EN”](#) for the settings that allow this fault to shut off CFET and/or DFET respectively. See [“Scan Will Not Start” on page 111](#) for conditions where this bit stops and prevents start of System Scans.

If unmasked by setting mask bit 0x83.0 to “0”, this bit also sets  $\overline{\text{ALRT}}$  low.

### 5.14.2 0x83 Priority Fault Mask

The Priority Fault Mask register masks the fault bits of the Priority Fault register from propagating to the  $\overline{\text{ALRT}}$  pin. The default value of “1” for each bit masks the related fault. Write a “0” to the bit to allow the fault to propagate to the  $\overline{\text{ALRT}}$  pin.

[Table 59](#) displays the format and default values of the Priority Fault Mask register.

**Table 59. 0x83 Priority Fault Mask Register**

Bits	D[7]	D[6]	D[5]	D[4]	D[3]	D[2]	D[1]	D[0]
Bit Name	VCCF MASK	OWF MASK	IOTF MASK	COCF MASK	DOCF MASK	DSCF MASK	UVF MASK	OVF MASK
Default	1	1	1	1	1	1	1	1

#### 5.14.3 0x64 ETAUX Fault

The ETAUX Fault register reports faults relevant to the measured voltages at the xT0 and xT1 pins. All bits in this register are latched high and can be cleared by writing a “0” to them, performing a chip RESET, or by writing a “1” to bit [“0x02.1 Clear Faults and Status”](#). They cannot be cleared while the condition that sets them HIGH is present. Contents and default values of the ETAUX Fault register are displayed in [Table 60](#). The function of these bits and polarity of the comparators is based on the assumption that an NTC thermistor voltage is the monitored input.

Bit [“0x24.2 ETA Connect”](#) must be set for ETAUX faults to shut off CFETs and DFETs per the bit setting of [“0x0E.3 CPWR”](#). Continuous scan is halted for a threshold violation regardless of the setting of ETA Connect.

DFET and CFET are turned off and remain off under the following conditions if bit 0x0E.3 CPWR is “0”:

[DCHRG1 AND (DUT0 OR DUT1 OR DOT0 OR DOT1)

OR

[CHRG1 AND (CUT0 OR CUT1 OR COT0 OR COT1)]

CFET is turned off and remains off under the following conditions if bit 0x0E.3 CPWR is “1”:

[CHRG1 AND (CUT0 OR CUT1 OR COT0 OR COT1)]

DFET is turned off and remains off under the following conditions if bit 0x0E.3 CPWR is “1”:

[DCHRG1 AND (DUT0 OR DUT1 OR DOT0 OR DOT1)]

For a detailed description of the settings for the operation of the CFETs and DFETs see [“Power FET Block”](#).

In SCAN mode, setting ETAUX Faults requires three consecutive results above/below the minimum/maximum (NTC Thermistors assumed) voltage thresholds if [“0x09.4 ETAUX Fault Delay”](#) is set to “1” while a continuous System Scan is running. See [“Scan Will Not Start”](#) for conditions where ETAUX faults stop and prevent start of System Scans.

These fault bits set regardless of current direction in IDLE mode if the related threshold voltage is violated.

The user selects whether the  $\overline{\text{ALRT}}$  pin is asserted LOW when one or more of these faults are triggered by programming the corresponding mask register bit [“0x84 ETAUX Fault Mask”](#).

**Table 60. 0x64 ETAUX Fault Register**

Bits	D[7]	D[6]	D[5]	D[4]	D[3]	D[2]	D[1]	D[0]
Bit Name	COT1	CUT1	DOT1	DUT1	COT0	CUT0	DOT0	DUT0
Default	0	0	0	0	0	0	0	0

#### 5.14.3.1 0x64.7 COT1

The Charge Over-Temperature Bit 1 of the ETAUX Fault register reports a fault if the xT1 voltage (0x5A-5B on [page 61](#)) is below the COT1 voltage threshold (0x18 on [page 59](#)) during charge. A “1” indicates a fault.

#### 5.14.3.2 0x64.6 CUT1

The Charge Under-Temperature Bit 1 of the ETAUX Fault register reports a fault if the xT1 voltage (0x5A-5B on [page 61](#)) is above the CUT1 voltage threshold (0x17 on [page 59](#)) during charge. A “1” indicates a fault.

#### 5.14.3.3 0x64.5 DOT1

The Discharge Over-Temperature Bit 1 of the ETAUX Fault register reports a fault if the xT1 voltage (0x5A-5B on [page 61](#)) is below the DOT1 voltage threshold (0x1A [page 59](#)) during discharge. A “1” indicates a fault.

#### 5.14.3.4 0x64.4 DUT1

The Discharge Under-Temperature Bit 1 of the ETAUX Fault register reports a fault if the xT1 voltage (0x5A-5B on [page 61](#)) is above the DUT1 voltage threshold (0x19 on [page 59](#)) during discharge. A “1” indicates a fault.

#### 5.14.3.5 0x64.3 COT0

The Charge Over-Temperature Bit 0 of the ETAUX Fault register reports a fault if the xT0 voltage (0x58-59 on [page 61](#)) is below the COT0 voltage threshold (0x14 on [page 59](#)) during charge. A “1” indicates a fault.

#### 5.14.3.6 0x64.2 CUT0

The Charge Under-Temperature Bit 0 of the ETAUX Fault register reports a fault if the xT0 voltage (0x58-59 on [page 61](#)) is above the CUT0 voltage threshold (0x13 on [page 59](#)) during charge. A “1” indicates a fault.

#### 5.14.3.7 0x64.1 DOT0

The Discharge Over-Temperature Bit 0 of the ETAUX Fault register reports a fault if the xT0 voltage (0x58-59 on [page 61](#)) is below the DOT0 voltage threshold (0x16 on [page 59](#)) during discharge. A “1” indicates a fault.

### 5.14.3.8 0x64.0 DUT0

The Discharge Under-Temperature Bit 0 of the ETAUX Fault register reports a fault if the xT0 voltage (0x58-59 on [page 61](#)) is above the DUT0 voltage threshold (0x15 on [page 59](#)) during discharge. A “1” indicates a fault.

### 5.14.4 0x84 ETAUX Fault Mask

The ETAUX Fault Mask register masks the fault bits of the ETAUX Fault register 0x64 from propagating to the  $\overline{\text{ALRT}}$  pin. The default value “1” of each bit masks the related fault. Write a “0” to the bit to allow the fault to propagate to the  $\overline{\text{ALRT}}$  pin.

The format and default values of the ETAUX Fault Mask register are displayed in [Table 61](#).

**Table 61. 0x84 ETAUX Fault Mask Register**

Bits	D[7]	D[6]	D[5]	D[4]	D[3]	D[2]	D[1]	D[0]
Bit Name	COT1MASK	CUT1 MASK	DOT1MASK	DUT1MASK	COT0MASK	CUT0MASK	DOT0MASK	DUT0MASK
Default	1	1	1	1	1	1	1	1

### 5.14.5 0x65 Other Fault Register

The Other Fault register reports various faults and warnings. All bits in this register are latched high and can be cleared by writing a “0” to them unless the condition that sets them HIGH is present. Unless noted otherwise in the bit descriptions below, these faults are cleared by writing “1” to Clear Faults and Indicators (0x02.1 on [page 43](#)), Soft Reset (0x01.7 on [page 40](#)), Reset To IDLE (0x01.6 on [page 40](#)) or a hardware reset with the  $\overline{\text{RESET}}$  pin. The format and default values of the Other Fault register are displayed in [Table 62](#).

**Table 62. 0x65 Other Fault Register**

Bits	D[7]	D[6]	D[5]	D[4]	D[3]	D[2]	D[1]	D[0]
Bit Name	VBOVF	VBUVF	CPMP NRDY	OW XT1	OW XT0	OW VBAT1	OW VSS	CRCF
Default	0	0	1	0	0	0	0	0

#### 5.14.5.1 0x65.7 VBOVF

The  $V_{\text{BAT1}}$  Overvoltage Fault bit reports the result of the  $V_{\text{BAT1}}$  overvoltage comparison. If the  $V_{\text{BAT1}}$  voltage reading (“[0x5C - 0x5D VBAT1 Voltage \(R\)](#)”) is above the “[0x20 VBAT1 OV Threshold](#)”, then this bit is set to “1”.

In SCAN mode, setting VBOVF requires a number of consecutive measured results, determined by “[0x09.5 Other Fault Delay](#)”, above the maximum voltage threshold while a continuous System Scan is running.

See “[0x24.1 DFET EN](#)” and “[0x24.0 CFET EN](#)” for the settings that allow this fault to shut off CFET and/or DFET respectively. See “[Scan Will Not Start](#)” for conditions where this fault stops and prevents start of System Scans.

#### 5.14.5.2 0x65.6 VBUVF

The  $V_{\text{BAT1}}$  Undervoltage Fault bit of the Other Fault register reports the result of the  $V_{\text{BAT1}}$  undervoltage comparison. If the  $V_{\text{BAT1}}$  voltage reading (“[0x5C - 0x5D VBAT1 Voltage \(R\)](#)”) is below the “[0x21 VBAT1 UV Threshold](#)”, then this bit is set to “1”.

In SCAN mode, setting VBUVF requires a number of consecutive measured results, determined by “[0x09.5 Other Fault Delay](#)”, below the minimum voltage threshold while a continuous System Scan is running.

See “[0x24.1 DFET EN](#)” and “[0x24.0 CFET EN](#)” for the settings that allow this fault to shut off CFET and/or DFET respectively. See “[Scan Will Not Start](#)” for conditions where this fault stops and prevents start of System Scans.

#### 5.14.5.3 0x65.5 CPMP NRDY

If the charge pump is enabled with bit “[0x24.7 CPMP EN](#)” set to “1”, the Charge Pump Not Ready bit indicates the status of the voltage at the VCPMP pin. A “1” indicates that the charge pump is not ready for use because the voltage is substantially below its proper operating range. The power FETs do not turn on if the bit is set. The device clears the CPMP NRDY bit automatically when the charge pump voltage is in an acceptable range.

If the charge pump is disabled with bit [“0x24.7 CPMP EN”](#) set to “0”, the CPMP NRDY bit is cleared (“0”). The CPMP NRDY fault can only be set if the charge pump is enabled and its voltage fails to rise above  $V_{\text{pmpMin}}$  ([page 16](#)) or falls below  $V_{\text{pmpFall}}$  ([page 16](#)).

If CPMP NRDY is “1” when the charge pump is enabled ( $0x24.7 = 1$ ), Cell Balancing on VC16 and continuous System Scans are inhibited and both C/DFET pins are shut off, but it does NOT clear either C/DFET\_EN register bits.

#### 5.14.5.4 0x65.4:5 OW xT1 xT0

The Open-Wire xT1 and xT0 bits indicate if an open-wire fault has occurred on pins xT1 and/or xT0. After ETAUX pins are measured, if the voltage reading is near VTEMP, the corresponding OW status bit is set to “1”.

The Open-Wire test function for pins xT1 and xT0 is not part of the open-wire test sequence. See [“Aux Pins Open-Wire Test” on page 93](#) for details.

#### 5.14.5.5 0x65.2 OW V<sub>BAT1</sub>

This bit is set to “1” when the voltage at the VC16 pin is higher than the voltage at the VBAT1 pin by  $V_{\text{OWth2}}$  ([page 17](#)). Because the VBAT1 pin supplies power to various circuits within the ISL94216, an open wire leading to this pin renders the device nonfunctional during the open, which leads to a POR at reconnection. A Schottky diode connected from VC15 to VBAT1 can be used to power the device during this fault condition. This enables the device to operate and alert the MCU to a VBAT1 open wire.

If the  $V_{\text{BAT1}}$  connection to the top cell is made through the pack high side load current wire and is separate from the VC15 and VC16 voltage sense connections to their respective cells, an open in the high side load current connection is detectable.

The open-wire test sequence does not test  $V_{\text{BAT1}}$  during discharge, when bit [“0x67.7 DCHRG1” on page 87](#) is “1”. See [“Open-Wire Function” on page 112](#) for details.

#### 5.14.5.6 0x65.1 OW VSS

This bit is set to “1” when the voltage at the VSS pin is significantly higher than the voltage at the VC0 and/or the VC1 pins while the chip runs an open-wire sequence that includes the comparisons of VSS vs VC1 and VSS vs VC0. See the Electrical Specifications ([“VOWth3” on page 17](#)) for the threshold voltage.

If the VSS connection to the bottom cell is made through the pack low side load current wire and is separate from the VC0 and VC1 voltage sense connections to their respective cells, an open in the pack low side load current connection is detectable. Because VSS is tied to CSN (and PACK-) the path from the VSS pin to the bottom of the pack includes the current sense resistor.

The open-wire test sequence does not test VSS during discharge. See [“Open-Wire Function” on page 112](#) for details.

#### 5.14.5.7 0x65.0 CRCF

The CRCF bit is set and latched by the ISL94216 if the 2-byte CRC word sent by the Master does not match the value calculated internally.

If this occurs during a write command the ISL94216 ignores it and the register value remains unchanged. In the case of a read command from the Master with an incorrect CRC, the ISL94216 holds the MISO pin high during the SCL cycles when the read-back data is expected by the Master until CS returns high, signaling there was an error with an all 1’s response.

As with the other bits in this register, this bit can be cleared by writing a “0” to it only if the condition that set the CRCF is cleared. Any valid Read or Write command can be used to clear the condition, and a valid Write command to this register can be used to clear the bit.

### 5.14.6 0x85 Other Fault Mask

The Other Fault Mask register masks the fault bits of the Other Fault register 0x65 from propagating to the  $\overline{\text{ALRT}}$  pin. The default value “1” of each bit masks the related fault. Write a “0” to the bit to enable the fault to propagate to the ALRT pin.

If bit 0x85.0 is set to “0”, then the Busy Bit ([“0x01.2 Busy”](#)) is inverted and output on the  $\overline{\text{ALRT}}$  pin. This is intended to prevent the MCU from reading measurement registers that may be in the process of being written by the ISL94216.

[Table 63](#) displays the format and default values of the Other Fault Mask register.

**Table 63. 0x85 Other Fault Mask Register**

Bits	D[7]	D[6]	D[5]	D[4]	D[3]	D[2]	D[1]	D[0]
Bit Name	VBOVF Mask	VBUVF Mask	CPMP NRDY Mask	RSV	RSV	RSV	CRCF MASK	BUSY Mask
Default	1	1	1	1	1	1	1	1

### 5.14.7 0x66 CB Status

The CB Status register reports cell balancing and charging related status for the ISL94216. All bits in this register are latched high unless otherwise noted and can be cleared by writing a “0” to them unless the condition that sets them HIGH is present. These bits also can be cleared by setting the Clear all Faults (0x02.1 on [page 43](#)) bit or executing one of the following actions: Soft Reset (0x01.7 on [page 40](#)), Reset To Idle (0x01.6 on [page 40](#)), or a hardware reset on the RESET pin.

The format and default values of the CB Status register are displayed in [Table 64](#).

**Table 64. 0x66 CB Status Register**

Bits	D[7]	D[6]	D[5]	D[4]	D[3]	D[2]	D[1]	D[0]
Bit Name	BAT FULL	IOTW	IEOC	VEOC	DVCF	2HI2CB	2LO2CB	NEED CB
Default	0	0	0	0	0	0	0	0

#### 5.14.7.1 0x66.7 BAT FULL

The Battery Full bit indicates that charging and auto cell balancing (if enabled) has completed. The conditions that set BAT FULL with cell balancing enabled are summarized below and detailed in [“Automatic Cell Balancing” on page 115](#).

For constant current charging with [“0x25.3 IEOC EN”](#) and [“0x25.1 CB EOC”](#) set to “0”, BAT FULL sets when the highest cell voltage reaches the [“0x2D VEOC Threshold”](#) and the bit [“0x66.4 VEOC”](#) is set.

If CB EOC is “1” and IEOC EN is “0”, once VEOC is set CFET and DFET shut off. BAT FULL is set when cell balancing reduces the cell voltages below the VEOC threshold.

For charge cycles that end with constant voltage charging (CB EOC = “0” and IEOC EN = “1”), BAT FULL sets after the cell voltages exceed the VEOC threshold (the VEOC bit is set and DFET shuts off) and the bit [“0x66.5 IEOC”](#) transitions from “0” to “1” due to the charge current dropping below the [“0x10 IEOC Threshold”](#).

If CB EOC is “1” and IEOC EN is “1”, once VEOC is set DFET shuts off. BAT FULL is set when IEOC changes from “0” to “1” due to the charge current dropping below the IEOC Threshold.

Whenever BAT FULL is set high, [“0x25.6 Auto CB EN”](#) is reset to “0”. The microcontroller must clear the BAT FULL bit before enabling the next cycle of automatic cell balancing (set AUTO CB EN to “1”).

#### 5.14.7.2 0x66.6 IOTW

The Internal Over-Temperature Warning bit indicates that an internal temperature sensor over-temperature warning event occurred. The bit is set if the internal temperature is above (voltage is below) the IOTW threshold at 0x22 ([“0x22 - 0x23 IOTW and IOTF Thresholds”](#)).

In SCAN mode, setting IOTW requires three consecutive results below the voltage threshold (NTC Temp Sensor) if [“0x09.5 Other Fault Delay”](#) is set to “1” while a continuous System Scan is running.

#### 5.14.7.3 0x66.5 IEOC

The Current End of Charge bit is set if CFET is “On”, the  $I_{PACK}$  voltage (0x52-53 on [page 46](#)) has dropped below the setting of [“0x10 IEOC Threshold”](#), and bit [“0x25.3 IEOC EN”](#) is set to “1”. A transition from “0” to “1” of the IEOC bit indicates the charge current has dropped below the IEOC Threshold. See [“Automatic Cell Balancing”](#).

The IEOC threshold voltage divided by the sense resistor value sets the IEOC current (see [“CSP and CSN Pins \(24, 25\)”](#)). The IEOC bit is not dependent on DCHRG1 or CHRGI.

#### 5.14.7.4 0x66.4 VEOC

The Voltage End Of Charge bit indicates the result of the comparison of the [“0x2D VEOC Threshold”](#) with the maximum cell voltage. A “1” indicates that one or more of the scanned cells voltage is above the threshold. Setting the VEOC bit is not dependent on DCHRG1 or CHRGI, and shuts off DFET and/or CFET in some cases, see [“Automatic Cell Balancing”](#).

When VEOC is clear (“0”), cell balancing during charging is enabled by [“0x25.0 CB CHRG”](#). When VEOC is set (“1”), cell balancing during charging is enabled by [“0x25.1 CB EOC”](#).

#### 5.14.7.5 0x66.3 DVCF

The Delta  $V_{CELL}$  Max Fault bit indicates the result of the digital comparison of the  $V_{CELL}$  Max Delta Threshold (0x08 on [page 47](#)) with the  $V_{CELL}$  Max Delta Voltage (0x50-51 on [page 45](#)). A “1” indicates the  $V_{CELL}$  Max Delta cell voltage has exceeded the  $V_{CELL}$  Max Delta threshold.

In SCAN mode, setting DVCF requires three consecutive results above the voltage threshold if [“0x09.6 Delta  \$V\_{CELL}\$  Fault Delay”](#) is set to “1” while a continuous System Scan is running.

#### 5.14.7.6 0x66.2 2HI2CB

The Too High To Cell Balance bit is set when the minimum of all the cell voltages is greater than [“0x2B CBMAX Threshold”](#). This bit inhibits cell balancing when set, and must be clear along with the condition that set it before cell balancing can start. The minimum of all cell voltages has to be below CBMAX - 5bits (~94mV hysteresis) before the ISL94216 clears this bit. Unlike the other bits in the register, 2HI2CB is not latched and clears automatically when the condition that set it clears.

#### 5.14.7.7 0x66.1 2LO2CB

The Too Low To Cell Balance bit is set when the maximum of all the cell voltages is lower than [“0x2C CBMIN Threshold”](#). This bit inhibits cell balancing when set, and must be clear along with the condition that set it before cell balancing can start. The maximum of all cell voltages has to be above CBMIN + 5bits (~94mV hysteresis) before the ISL94216 clears this bit. Unlike the other bits in the register, 2HO2CB is not latched and clears automatically when the condition that set it clears.

#### 5.14.7.8 0x66.0 Need CB

The Need Cell Balancing bit of the CB Status register is set when the difference between one or more of all the measured cell voltages and the minimum of all of them is greater than the [“0x2A CB Min Delta Threshold”](#). The comparison is valuated as soon as a set of cell voltage measurements completes. A “1” indicates cell(s) need balancing.

If AUTO CB EN = 0, the Need CB bit is just an indicator to the user. See [Auto CB Sequence Figure 109 on page 116](#).

### 5.14.8 0x86 CB Status Mask

The Cell Balancing Status Mask register masks the status bits of the CB Status register (0x66) to prevent the status indicator from propagating to the  $\overline{ALRT}$  pin. The default value “1” of each bit masks the related status bit. Write a “0” to the bit to enable the status to propagate to the  $\overline{ALRT}$  pin.



[Table 65](#) displays the format and default values of the CB Status Mask register.

**Table 65. 0x86 CB Status Mask Register**

Bits	D[7]	D[6]	D[5]	D[4]	D[3]	D[2]	D[1]	D[0]
Bit Name	BAT FULL MASK	IOTW MASK	IEOC MASK	VEOC MASK	DVCF MASK	2HI2CB MASK	2LO2CB MASK	NEED CB MASK
Default	1	1	1	1	1	1	1	1

### 5.14.9 0x67 Status

The Status register reports the general status of the ISL94216 with monitors for load, charge and discharge. It also has regulator, reference and other fault bits. All bits in this register are latched high unless otherwise noted and can be cleared by writing a “0” to them, performing a chip  $\overline{\text{RESET}}$ , or by writing a “1” to the Clear Faults and Indicators bit (0x02.1). They cannot be cleared while the condition that sets them HIGH is present. [Table 66](#) displays the format and default values of the Status register.

**Table 66. 0x67 Status Register**

Bits	D[7]	D[6]	D[5]	D[4]	D[3]	D[2]	D[1]	D[0]
Bit Name	DCHRGI	CHRGI	CH PRESI	LD PRESI	OTHER FAULTS	IREG1	IREG2	VTMPF
Default	0	0	0	0	0	0	0	0

#### 5.14.9.1 0x67.7 DCHRGI

The Discharge Current Indicator bit indicates if charge is being removed from the battery pack in SCAN mode. If the current sense voltage measurement is less than approximately  $-200\mu\text{V}$  (-20 decimal register value), the DCHRGI bit is set. This bit is not latched and indicates the current direction of the last pack current measurement. If cleared by the MCU it will remain clear until the next pack current measurement.

In continuous Scan mode, setting DCHRGI requires three consecutive measurements below  $-200\mu\text{V}$  if [“0x03.1 I<sub>DIR</sub> Delay”](#) is set to “1”.

When discharging with a series power FET configuration ([“0x0E.3 CPWR”](#) is set to “0”), the discharge temperature limits are applied to the ETAUX pin measurements ([“ETAUX Detectors”](#)) in SCAN mode. If any ETAUX measurement exceeds the discharge limits and [“0x24.2 ETA Connect”](#) is enabled, both power FETs are turned OFF. For a parallel FET configuration (CPWR = 1), only DFET is shut OFF.

#### 5.14.9.2 0x67.6 CHRGI

The Charge Current Indicator bit indicates if charge is being supplied to the battery pack in SCAN mode. If the current sense voltage measurement is greater than approximately  $+200\mu\text{V}$  (+19 decimal register value), the CHRGI bit is set. This bit is not latched and indicates the current direction of the last pack current measurement. If cleared by the MCU it will remain clear until the next pack current measurement.

In continuous Scan mode, setting CHRGI requires three consecutive measurements above  $200\mu\text{V}$  if [“0x03.1 I<sub>DIR</sub> Delay” on page 44](#) is set to “1”.

When charging with a series power FET configuration (CPWR = 0), the charge temperature limits are applied to the ETAUX pin measurements ([“ETAUX Detectors”](#)) in SCAN mode. If any AUX measurement exceeds the charge limits and [“0x24.2 ETA Connect”](#) is enabled, both power FETs are turned OFF. For a parallel FET configuration (CPWR = 1) only the CFET is shut OFF.

#### 5.14.9.3 0x67.5 CH PRESI

The Charger Present bit continuously follows the state of the  $\overline{\text{WAKEUP}}$  pin (inverted) and is not latched. If  $\overline{\text{WAKEUP}}$  is low, the CH PRESI bit is “1”. When the  $\overline{\text{WAKEUP}}$  pin is high, the CH PRESI bit is “0”.

#### 5.14.9.4 0x67.4 LD PRESI

The Load Present bit indicates that a load is connected, if the DFET is disabled. The bit is “0” when the load connection detection function is off. See [Figure 85 on page 54](#).

If a load is attached during LOW POWER mode and the Load Connection Detection function is enabled (“0x0E.1 LDLP” is “1”), then the device transitions to IDLE mode on the rising edge of LD PRESI. See [Figure 105 on page 103](#).

Though this bit is latched, it can be cleared by the LDLP and ELR (“0x0E.4 ELR”) functions if either or both are enabled.

#### 5.14.9.5 0x67.3 Other Faults

The Other Faults bit of the Status register “ORs” the communication time out, and oscillator frequency error bits. If a serial communication transaction has not occurred in  $t_{COM}$  ([page 17](#)) time while in IDLE mode, the flag is set and the device changes to LOW POWER mode. The  $t_{COM}$  timeout fault can be ignored by setting bit “0x1F.1 Communication Timeout EN” to “0”. If the frequency of any of the on-chip oscillators is too high or too low, the bit is set.

#### 5.14.9.6 0x67.2 IREG1

The Regulator overcurrent 1 indicator reports an overcurrent event has occurred while in IDLE or SCAN Modes. The  $I_{REGOC1}$  threshold at 0x1D (“0x1D.1E IREGOC1, 2 Threshold” on [page 65](#)) is compared to the  $I_{REG}$  Voltage (“0x61-62 IREG Voltage (R)” on [page 66](#)) to determine this indicator. A “1” indicates a failure has occurred.

This fault shuts off both CFET and DFET and stops System Scan.

#### 5.14.9.7 0x67.1 IREG2

The Regulator overcurrent 2 indicator reports an overcurrent event has occurred while in LOW POWER mode. The  $I_{REGOC2}$  threshold at 0x1E (“0x1D.1E IREGOC1, 2 Threshold” on [page 65](#)) is compared to the  $I_{REG}$  Voltage (“0x61-62 IREG Voltage (R)” on [page 66](#)) to determine this indicator. A “1” indicates a failure has occurred.

#### 5.14.9.8 0x67.0 VTMPF

The VTEMP Fault bit reports an undervoltage condition of the VTEMP pin voltage. A “1” indicates a failure has occurred. It is set when the measurement of the VTEMP voltage is lower than the  $VTEMP_{MIN}$  voltage threshold (1.1V, [page 16](#)).

This fault shuts off both CFET and DFET and stops System Scan.

#### 5.14.10 0x87 Status Mask

The Status Mask register masks the bits of Status register 0x67 from asserting the  $\overline{ALRT}$  pin low. The default value of each of the bits in this register is “1” (masked). [Table 67](#) provides the definition of the Status Mask register. Write a “0” to the bit to allow signals to pass to the  $\overline{ALRT}$  pin.

**Table 67. 0x87 Status Mask Register**

Bits	D[7]	D[6]	D[5]	D[4]	D[3]	D[2]	D[1]	D[0]
Fault Masked	DCHRG1	CHRG1	CH PRESI	LD PRESI	OTHER FAULTS	IREG1	IREG2	VTMPF
Default	1	1	1	1	1	1	1	1

#### 5.14.11 0x68-69 Open-Wire Status

Each bit in the Open-Wire Status register corresponds to one battery cell. During an open-wire test sequence (see [“Open-Wire Function” on page 112](#)), the ISL94216 connects a resistor, one cell at a time, between the VCn and VCn-1 pins (n = 1:16), and measures the voltage  $V(VCn, VCn-1)$ . “OW Celln” is set to “1” if the measured voltage is below a threshold when measuring  $V(VCn, VCn-1)$ . See the Electrical Specifications (“VOWth1” on [page 17](#)) for the threshold voltage. A bit can be set if either wire to Celln is open. An open-wire on pin VC0 is indicated with bit 0x69.0 set to “1”.



To clear these fault bits, first reconnect the faulty wire(s) to the battery pack and execute an open-wire sequence. All bits in this register are latched high and can be cleared by writing a “0” to them, performing a chip RESET, or by writing a “1” to the Clear Faults and Indicators bit (0x02.1). They cannot be cleared while the condition that sets them HIGH is present.

**Note:** Open Wire status of pins xT0, xT1, VSS, and V<sub>BAT1</sub> are in the [“0x65 Other Fault Register” on page 83](#).

**Table 68. 0x68 OW Status Register**

Bits	D[7]	D[6]	D[5]	D[4]	D[3]	D[2]	D[1]	D[0]
Bit Name	OW Cell16	OW Cell15	OW Cell14	OW Cell13	OW Cell12	OW Cell11	OW Cell10	OW Cell9
Default	0	0	0	0	0	0	0	0

**Table 69. 0x69 OW Status Register**

Bits	D[7]	D[6]	D[5]	D[4]	D[3]	D[2]	D[1]	D[0]
Bit Name	OW Cell8	OW Cell7	OW Cell6	OW Cell5	OW Cell4	OW Cell3	OW Cell2	OW Cell1
Default	0	0	0	0	0	0	0	0

### 5.14.12 0x88-89 Open-Wire Mask

The Open-Wire Mask is used to prevent an open-wire failure on selected cell(s) from propagating to the  $\overline{\text{ALRT}}$  pin and spans two 1-byte registers. Set the bits corresponding to unused cells to “1” in this register and in registers [“0x04 - 0x05 Cell Select” on page 44](#).

If the Open-Wire Mask bit is “0” and an open-wire failure occurs on that cell,  $\overline{\text{ALRT}}$  goes low to indicate a fault.

**Table 70. 0x88 OW Mask Register**

Bits	D[7]	D[6]	D[5]	D[4]	D[3]	D[2]	D[1]	D[0]
Fault Masked	OWM Cell16	OWM Cell15	OWM Cell14	OWM Cell13	OWM Cell12	OWM Cell11	OWM Cell10	OWM Cell9
Default	1	1	1	1	1	1	1	1

**Table 71. 0x89 OW Mask Register**

Bits	D[7]	D[6]	D[5]	D[4]	D[3]	D[2]	D[1]	D[0]
Fault Masked	OWM Cell8	OWM Cell7	OWM Cell6	OWM Cell5	OWM Cell4	OWM Cell3	OWM Cell2	OWM Cell1
Default	1	1	1	1	1	1	1	1

## 6. Pin Functionality

### 6.1 VC<sub>n</sub> Pins

The VC0-VC16 pins are the voltage sense inputs of the ISL94216 and are used in pairs to differentially measure each cell voltage. Positive pin VC<sub>n</sub> and negative pin VC<sub>n-1</sub> are connected to the ADC through a multiplexer. Each voltage sense input uses an external filter to protect against battery voltage transients. The basic input filter structure, with capacitors to the local ground, provides protection against transients and EMI for the cell inputs. They carry the loop currents produced by EMI and should be placed as close to the battery connector as possible. The ground terminals of the capacitors must be connected directly to a solid ground plane. Any vias should be placed in line to the signal inputs so that the inductance of these forms a low pass filter with the grounded capacitors.

The filtered battery cell voltages internally connect to the cell voltage monitoring system. The monitoring system contains a multiplexer to select a specific input, and an analog to digital converter.

The components of the “T” network (see [Figure 97](#)) provide a current limit function during hot plug events. The typical application has a total of ~232Ω series isolation resistance between the VC<sub>n</sub> inputs and the cells, with R<sub>1</sub> set to 50Ω and R<sub>5</sub> at 182Ω.

The recommended value for C<sub>1</sub> is 0.33μF. A short in one of these capacitors dissipates the charge in the battery cell if left uncorrected for an extended period of time. Renesas recommends that capacitors connected to cells are “fail safe” or “open mode” types.

Component values for the remaining resistors in [Figure 97](#) are listed in the [CB<sub>n</sub> Pins](#) section.

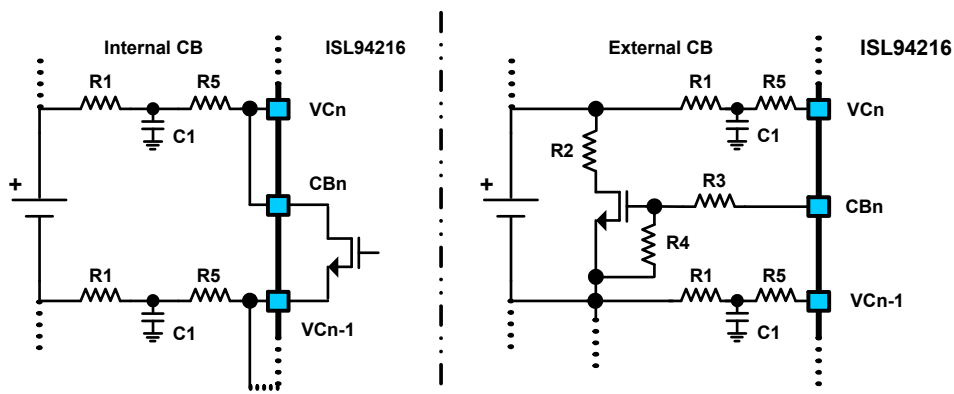

Figure 97. Voltage Sense and Cell Balance Pin Connections

See [“Reduced Cell Count” on page 137](#) for instructions about connecting unused VC<sub>n</sub> and CB<sub>n</sub> pins in systems with fewer than 16 cells.

### 6.2 CB<sub>n</sub> Pins

The CB1 - CB16 pins are the Cell Balance (CB) outputs of the ISL94216. They can be configured to use internal FETs or to drive external NMOS cell balancing FETs. The current drive for external FETs is ~25μA (I<sub>ECB</sub>, [page 16](#)). The current sources are turned on and off as needed to control the external devices. The ISL94216 uses only N-channel FETs for the external balancing function.

[Figure 97](#) shows the recommended cell balancing and voltage monitoring external component configuration. In the Internal CB configuration, the cell voltage is monitored through the cell balance resistors.

The external cell balance transistor requires two extra resistors for bias and pin protection. Set the value of R3 to 10KΩ and set R4 to 200kΩ ([Figure 97](#)). With a CB pin typical output current of 25μA, the cell balance transistor would see about 5V from gate to source.

Cell Balancing current is determined by the cell voltage divided by the resistance in the path from Cell+ through the CB FET to Cell-. The following equations assume configurations from [Figure 97](#) and component values from [“VCn Pins” on page 90](#).

For the external case, the CB current (CBI) is determined by the value of R2 and the FET on resistance:

$$CBI = V_{CELL} / (R2 + R_{DSON})$$

For the internal case, CBI is determined by the values of R1, R5, and the FET on resistance.

$$CBI = V_{CELL} / [2 \times (R1 + R5) + R_{CB\_ON}]$$

The internal CBI is obtained by assuming the nominal value for the internal CB FET  $R_{CB\_ON}$  of 70Ω ([page 16](#)).

$$CBI = V_{CELL} / [2 \times (R1 + R5) + R_{CB\_ON}] = 4.2V / [2 \times (232\Omega) + 70\Omega] = \sim 8mA$$

Internal power dissipation of the ISL94216 increases when internal cell balancing is used (see [“0x25.5 CB Configuration” on page 73](#) and [Equation 24](#)). This must be accounted for in the system design to avoid triggering an Internal Over-Temperature Fault ([“0x63.5 IOTF” on page 80](#)).

The Cell Balance pins should not be driven by an external source.

### 6.3 CSP and CSN Pins (24, 25)

The current monitor circuit tracks charge and discharge currents. The differential input voltage is sampled within System Scans (see [“0x03.7 I<sub>PACK</sub>\\_EN” on page 43](#)) or with a trigger command ([“0x03.0 I<sub>PACK</sub>\\_Trigger” on page 44](#)). Current is monitored by measuring the differential voltage across a current sense or “shunt” resistor connected between the CSP and CSN pin filters. This is a “Low Side” implementation; the Current Sense Positive (CSP) pin filter is connected to the bottom of the cell-stack (negative terminal of Cell 1) and the Current Sense Negative (CSN) pin filter is connected to PACK-, the negative load/charge terminal and system/board ground ([Figure 93 on page 70](#)).

The ISL94216 compares the voltage across the sense resistor to several thresholds. The thresholds are discharge short-circuit, discharge overcurrent, and charge overcurrent (pages [page 49](#) to [page 50](#) and [page 55](#)). For short circuit detection an analog comparator is used instead of the sampled I<sub>PACK</sub> measurement. If the measured voltage exceeds the selected limit beyond the chosen duration of time, the ISL94216 acts to protect the system ([page 49](#)).

The current monitor tracks the direction of the current with digital comparators to determine if the battery is being charged or discharged (pages [page 44](#) and [page 87](#)). If either condition is detected, the ISL94216 sets an appropriate flag. Discharge currents produce a negative voltage and charge currents produce a positive voltage. If the voltage drop across R<sub>SHUNT</sub> is between approximately ±200μV ([“I<sub>Zero</sub>\\_THR” on page 14](#)), then neither charge or discharge condition is set.

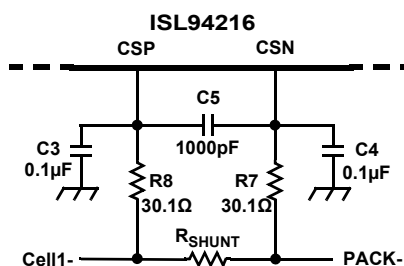

Figure 98. Current Sense Pin Connections

Recommended component values for the current monitor external circuitry are shown in [Figure 98](#). Resistors R7 and R8 are chosen to minimize any error contributed by the pin’s input current (~10μA) when the voltage is being measured. Capacitors C3 and C4 typically range from 1-100nF depending on the application.

The value of R<sub>SHUNT</sub> is application specific and must be determined based on peak and nominal load currents, charge current and end of charge current.

The maximum measurable voltage drop across  $R_{SHUNT}$  is approximately -642mV for a discharge current. During charge the maximum measurable voltage is about 350mV. See [“0x0A DSC Threshold”](#), [“0x0B DOC Threshold”](#), and [“0x0F COC Threshold”](#) for current threshold settings.

While the overcurrent limits and operating maximum currents set the upper range of possible values for  $R_{SHUNT}$  the minimum value is often determined by the desired End Of Charge Current Threshold ([“0x10 IEOC Threshold on page 78”](#)) and the zero current thresholds relative to the operational minimum current ([“ \$I\_{Zero\\_THR}\$ ” on page 14](#)). Current measurements are compared to the IEOC threshold when the IEOC EN bit ([“0x25.3 IEOC EN” on page 74](#)) is set. The comparison determines the state of the BAT FULL bit ([“0x66.7 BAT FULL” on page 85](#)). For more detail about how IEOC is used in cell balancing see [“Automatic Cell Balancing” on page 115](#).

It is not recommended to operate at the extreme limits of the inputs. In an application care should be taken to guard-band against additional noise and transients that can cause current levels to reach or exceed the maximum limits. When the ISL94216 is consistently at or below threshold ([“ \$I\_{Zero\\_THR}\$ ” on page 14](#)), the device may transition to LOW POWER mode. See [“0x2E.5:3 Low Power Timer” on page 101](#).

## 6.4 VSS Pin (26)

VSS is the ISL94216 analog ground pin. It must have a solid connection to the ground plane(s). The digital and analog ground planes should connect together as close to the VSS pin as possible. The Exposed Pad (EPAD) on the bottom of the ISL94216 must also be tied to analog ground. Multiple vias are recommended for good thermal conductivity.

The PACK- side of the current sense resistor must also be connected to the system and VSS ground planes ([Figure 93 on page 70](#)).

## 6.5 AUX0/xT0, VTEMP, AUX1/xT1 Pins (27, 29, 28)

### 6.5.1 External Components

AUX0/xT0 (pin 27) and AUX1/xT1 (pin 29) are auxiliary analog voltage input pins, also referred to as the ETAUX pins. Although they can be general purpose, these pins are optimized to work with external NTC thermistors to monitor the temperature of the battery pack if used in combination with the VTEMP output (Pin 28), as shown in [Figure 99](#). When used as analog inputs, Pins 27 and 29 are called the “AUX pins”. When connected for temperature sense they are “xT0” and “xT1”.

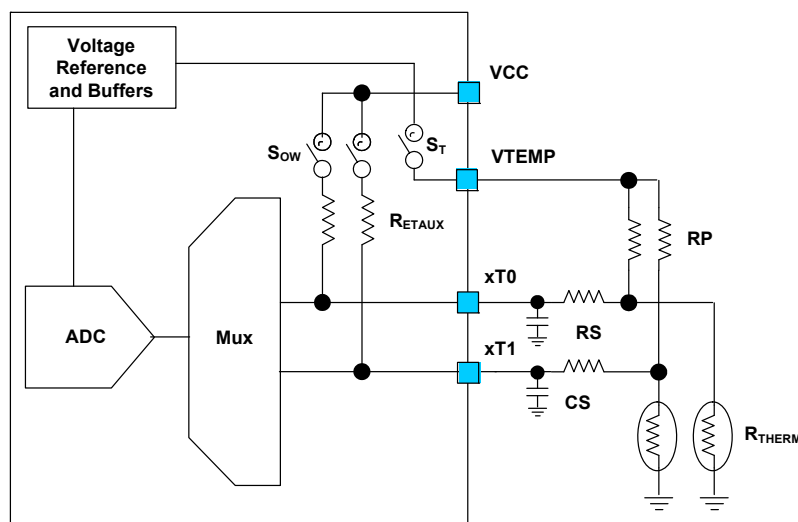

Figure 99. ETAUX Pin Configuration

The ETAUX inputs are sampled either as part of System Scans (see [“0x11.7:6 ETAUX Enable” on page 56](#)) or with a trigger command ([“0x11.0 ETAUX Trigger” on page 57](#)). Before measurement, internal switch  $S_T$  is closed, connecting the two pull-up resistors  $R_P$  through the VTEMP pin to the reference voltage. This sets up a pair of voltage dividers consisting of  $R_P$  and  $R_{THERM}$ . The voltage between these resistors is a function of the

temperature of  $R_{THERM}$ . This voltage is connected through the low pass filters consisting of  $R_S$  and  $C_S$  to the  $xT0$  and  $xT1$  inputs. Each of these inputs is measured in sequence relative to  $VSS$ . Switches  $S_{OW}$  are used only for Open-Wire test and must be open for accurate measurements.

Recommended values for the  $R_S$  resistors are  $10k\Omega$  and  $0.01\mu F$  for  $C_S$  capacitors.  $R_P$  values should match the nominal value of the thermistors used, with  $10k$  and  $100k$  supported. Thermistors  $R_{THERM}$  are usually located within the battery pack to monitor the cell temperature(s). Because the thermistors have a known value versus temperature the temperature can be calculated based on the voltage divider created between  $R_{THERM}$  and  $R_P$  given the known values for  $VTEMP$  and  $R_P$ .

The  $VTEMP$  pin is the switched output of an analog buffer which forces the reference voltage at the pin when selected. This pin operates as an analog output and should not be driven by an external source.

### 6.5.2 Aux Pins Open-Wire Test

The auxiliary pins ( $xT0$ ,  $xT1$ ) are tested for opens indirectly and are not part of the open-wire test sequence. After the pin voltages are measured, either during system-scan or a stand-alone measurement, if their resulting voltage readings are high relative to  $VTEMP$ , the corresponding OW status bit is set high.

To test for or verify an OW on  $xT0$  or  $xT1$ , connect the internal  $R_{ETAUX}$  (page 15) pull-up resistors by setting bit “0x09.7 AUX/xTn Pull-Up” on page 48 to “1”. This bit closes switches  $S_{OW}$  as shown in Figure 99 when set to “1”. Next, trigger an auxiliary pin measurement with “0x11.0 ETAUX Trigger” on page 57. The voltage reads full scale if the connection at the pin is open with the  $R_{ETAUX}$  resistors connected between the  $VCC$  pin and the auxiliary pins.

After the open-wire test of these pins, disconnect the internal pull-up resistors by setting the AUX Pull-up bit back to “0”.

## 6.6 Regulator and Supply Pins (30-33)

The ISL94216 has an internal regulator that uses an external power transistor to provide regulated voltages for its internal circuits. The output of this regulator can also power other system circuitry, including the microcontroller. See Figure 100 while reviewing sections “VCC Pin (30)” through “BASE Pin (33)” on page 94.

The EMITTER and  $VDD$  pins are connected through a multiplexer to the ADC, enabling the ISL94216 to monitor the regulator load current. The maximum voltage permitted across  $R_{SH}$  is  $344mV$  (“0x1D.1E IREGOC1, 2 Threshold”), this limits the selection of the sense resistor  $R_{SH}$ .

These pins are to be connected per Figure 100 and should not be driven from external sources.

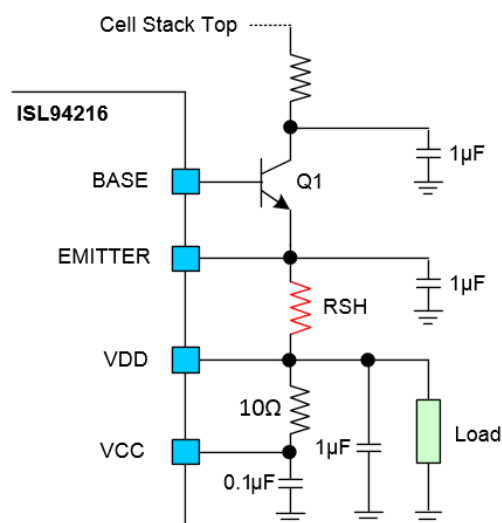

Figure 100. External Power Supply Components

### 6.6.1 VCC Pin (30)

The VCC pin is the analog 3.3V power supply input. External loads should not be tied to this pin. It connects externally to the VDD pin through a resistor and has a decoupling capacitor to VSS (analog ground). The VCC pin is also a sense input to the internal multiplexer and ADC used to determine if the regulator is functioning properly.

### 6.6.2 VDD Pin (31)

The VDD pin is the digital 3.3V power supply input. It connects externally to the VCC pin through a resistor and has a decoupling capacitor to DGND (digital ground). This pin also connects to an off-chip sense resistor (RSH) tied to the EMITTER pin in the regulator's feedback loop. The VDD and EMITTER pins are sense inputs to the internal multiplexer and ADC; together they are used to monitor the voltage across the off-chip sense resistor to determine the regulator current (see ["0x61-62 IREG Voltage \(R\)" on page 66](#)). The VDD pin is also the feedback point for the regulator.

This node can support external loads, the regulator is designed to source but not sink current. The source current is limited by the available base current, the power dissipation tolerance of RSH, Q1 and its collector resistor.

### 6.6.3 EMITTER Pin (32)

The EMITTER pin connects to an off-chip sense resistor and the emitter terminal of the off-chip NPN in the regulator's loop. The other end of the sense resistor connects to the VDD pin.

### 6.6.4 BASE Pin (33)

The BASE Pin drives the base terminal of the external NPN transistor in the regulator's loop. The amplifier driving the BASE pin sources a minimum of 1mA across the operating temperature range. This allows a maximum regulation current of around 100mA given a minimum NPN  $\beta$  of 100.

Use this pin only to drive the base pin of an external NPN as part of the regulator loop. It is not intended for any other purpose.

The NPN collector connection to the pack voltage should be routed separately to the battery pack from the high current load path to minimize any transient effects. A resistor should be placed between the collector and the pack along with a decoupling capacitor from collector to DGND. The value of the resistor is dependent on the expected collector current and the transistor chosen.

## 6.7 CMS0 and CMS1 Pins (34, 35)

The CMS0 and CMS1 pins select the communication protocol for the ISL94216 (see ["Serial Protocol Defined" on page 120](#)). They must be connected to DGND or VDD when power is applied.

### 6.8 DGND Pin (36)

DGND is the digital ground reference pin of the ISL94216. It must have a solid connection to the digital ground plane. If separate digital and analog ground planes are used, they should be connected together at the VSS pin.

### 6.9 V2P5 Pin (37)

The V2P5 pin is the internal 2.5V digital power supply. External connections must be limited to a decoupling capacitor to DGND. This pin is for internal use only. Do not load or drive this pin from an external source.

### 6.10 $\overline{\text{RESET}}$ Pin (38)

The  $\overline{\text{RESET}}$  pin requires a pull-up resistor connected to  $V_{DD}$ , 100k $\Omega$  recommended. The pin is used to exit out of any mode and restores the factory default settings. The reset pin is referenced to the DGND pin.

When  $\overline{\text{RESET}}$  is low, all the flip-flops return to the default state, all chip functions are disabled, and all bits are reset to default values. After  $\overline{\text{RESET}}$  transitions from low to high, the fuses are read and internal calibration is performed. The chip has a communication lockout of  $t_{\text{RESET}}$  and POR lockout of  $t_{\text{StartUp}}$  ([page 18](#)). The whole power-up sequence takes the amount of time specified by  $t_{\text{StartUp}}$ . After all actions are complete, the device transitions to IDLE mode.

If  $V_{BAT1}$  voltage goes below  $V_{POR}$ , the actions by the chip are the same as if holding  $\overline{RESET}$  pin low. When  $V_{BAT1}$  rises above  $V_{POR}$ , the action is equal to  $RESET$  transitioning from low to high.

### 6.11 $\overline{WAKEUP}$ Pin (39)

The  $\overline{WAKEUP}$  pin is a digital input pin driven by the microcontroller to inform the ISL94216 that a charger is present. CH PRES1 bit tracks the setting of this pin. The ISL94216 transitions to IDLE mode when  $\overline{WAKEUP}$  transitions from a high to low if in SHIP or LOW POWER mode. The mode remains unchanged if in SCAN mode.

A 100k $\Omega$  pull-up to VDD is recommended.

### 6.12 $\overline{ALRT}$ Pin (40)

The  $\overline{ALRT}$  pin is an active low digital output pin the ISL94216 uses to inform the microcontroller of a fault or status change. Faults, status bits, and mode transitions due to activity such as load attachment or inactivity such as no charge/discharge current can be unmasked (registers 0x83-89) to connect the bit state to the pin. A 100k $\Omega$  pull-up to VDD is recommended.

Unmasked incidences causing transitions to either SHIP or LOW POWER Modes hold the  $\overline{ALRT}$  pin low for a minimum of time specified by  $t_{REGSW}$  (page 16) before releasing it to conserve power.

The  $\overline{ALRT}$  Pulse Enable bit of the GPIO Operation register ("[0x12.6 ALRT Pulse EN](#)" on page 58) drives the  $\overline{ALRT}$  pin in a more power efficient manner when set to "1" (see [Figure 101](#)). When the bit is enabled, the ISL94216 turns on the  $\overline{ALRT}$  pin NMOS device for 2ms within a 10ms period if an alert is active. A "0" (Default) sets the circuit to constant drive.

The  $\overline{ALRT}$  pin is configured as a digital output pin and should not be driven by an external source.

### 6.13 $\overline{ADDR/CS}$ Pin (41)

The  $\overline{ADDR/CS}$  pin is used by both I<sup>2</sup>C and SPI communications protocols. If I<sup>2</sup>C is selected, then this pin is designated ADDR and it determines the device address. See "[I<sup>2</sup>C Address Values](#)" on page 120 for details. When used as an address pin, it should be permanently tied to either VDD or DGND depending on desired address. The ADDR pin should not change state while the ISL94216 is powered, if it does a device RESET may be required to recover.

If the SPI protocol is selected, then pin 41 is designated as  $\overline{CS}$  (Chip Select) and is active low. This pin is a digital input and is driven only by the master. A 100k $\Omega$  pull-up to VDD is recommended.

### 6.14 SCL Pin (42)

The SCL pin is the communications clock pin driven by the master for I<sup>2</sup>C and SPI communications protocols. A pull-up of 4.7-10k $\Omega$  to VDD is recommended.

### 6.15 MOSI Pin (43)

The Master Output Slave Input pin is a digital input for the SPI protocol. The MOSI pin is driven only by the master and is monitored by the slave when  $\overline{CS}$  is pulled low. No pull-up is required by the ISL94216, but it may be needed depending on the master.

This pin is not used if either of the other protocols are chosen.

### 6.16 MISO/SDA/SINGLE-WIRE Pin (44)

The MISO/SDA/SINGLE-WIRE pin is used by all three communications formats as determined by the CMS0 and CMS1 pins.

For I<sup>2</sup>C communications the pin is the Serial Data (SDA) input/output pin. It is driven by the master for sending a slave address byte and for write commands. The pin is driven by the slave for data reads. In this mode the device pin is an open drain. For this protocol a 4.7-10k $\Omega$  pull-up to VDD is recommended.

In SPI mode the Master Input Slave Output (MISO) pin is a CMOS serial data output pin from the slave to the master. No pull-up is necessary on this pin for SPI mode.



Single Wire applications use this CMOS I/O pin as the only communications port. It is driven by the master or slave depending on the symbol sequence/timing. A 4.7kΩ pull-up to VDD is recommended for this protocol.

When operating as a digital output this pin should not be driven by an external source.

### 6.17 GPIO(0-3) Pin (45-48)

The General Purpose Input/Output pins are user configurable (see [“0x12.5:4 GPIO CONFIG” on page 58](#)) as a group as inputs or outputs. They cannot be configured individually.

If configured as inputs, the GPIO pins set the bit values of the GPIO Status bits. If configured as Outputs or Drive LED, the GPIO pins reflect the bit values of the GPIO Status bits. In Drive LED mode the active outputs are pulled low for 2ms out of every 10ms to save power, as illustrated by [Figure 88](#). These pins require pull-up resistors when configured as outputs. The pull-up resistor value for the pin should be greater than  $R_{GPIO\_PU}$  ([page 17](#)).

The FETs Out selection connects GPIO2 to the DFET logic signal and GPIO3 to the CFET logic signal. This enables the ISL94216 to control a low side FET configuration. [Table 29 on page 59](#) defines the logic state of the GPIO pins versus DFET and CFET state. GPIO1 is configured as a FETS OFF digital input pin. If the logic state is high, both DFET and CFET turn off. If the logic state is low, the DFET and CFET logic signals pass to GPIO2 and GPIO3. GPIO0 is configured as a FETs ON digital output pin. The output of the pin is high until CFET and DFET are both off.

The GPIO pins can tolerate up to 5V inputs when the ISL94216 is operated with VCC and VDD of 3.3V. If configured as digital outputs, these pins must not be driven by an external source.

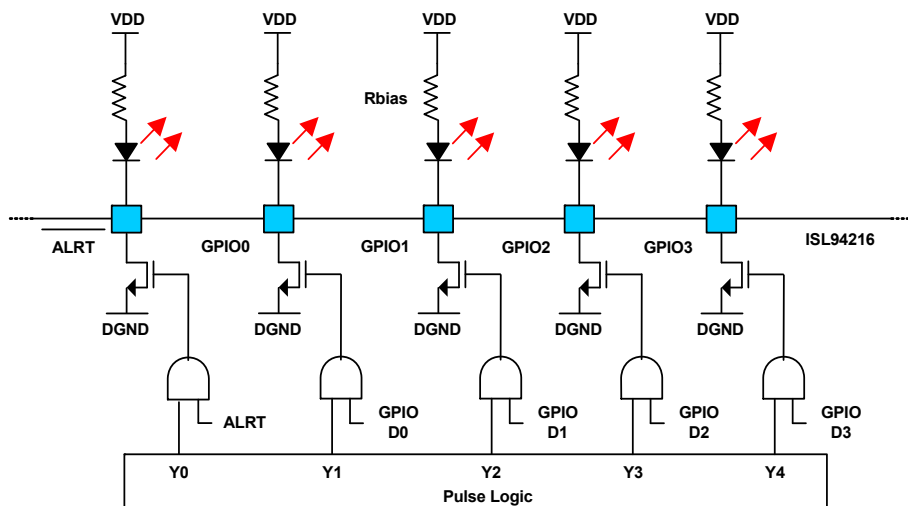

Figure 101.  $\overline{\text{ALRT}}$  Pulse EN and GPIOx Drive LEDs

### 6.18 LDMON Pin (49)

The LDMON pin of the ISL94216 is used for load connection detection ([Figure 85 on page 54](#)) and for short-circuit load release detection ([Figure 83 on page 51](#)). The ISL94216 monitors the voltage at this pin, which is connected to the load side of the DFET through an isolation resistor ([Figure 102](#)). A Schottky diode (not pictured) may be added to protect the LDMON pin from excessive transients in high current applications, the diode must be oriented to enable current flow out of the LDMON pin.

The load detect function only operates when DFET is off. It connects an on-chip pull-up resistor, determined by the [“0x0E.6:5 ELD” on page 52](#) setting, between the LDMON and VBAT2 pins. If PACK+ has no load, then the LDMON pin voltage is pulled above the load detect threshold  $V_{LDThr}$  (1.2V nominal, [page 15](#)). When a load is present, the LDMON voltage is determined by the voltage division between the internal resistance selected by ELD and the load connected between PACK+ and PACK-.



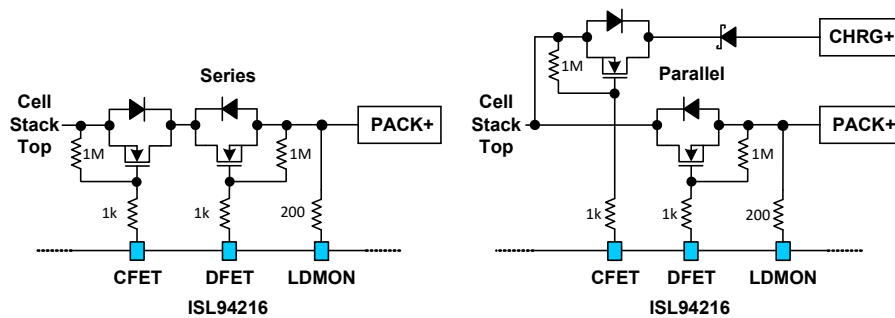

Figure 102. CFET, DFET and LDMON Connections

Setting bit “0x0E.4 ELR” on page 53 to “1” (default) enables the Short Circuit Recovery Sequence. If a short-circuit is detected, the load recovery circuitry tests for load removal after a delay of  $t_{LDEN}$  (page 15) plus  $t_{LDDELAY}$  (“0x1B.3:2 LD Delay” on page 64) following the shut off of DFET. If the ELR bit is set to “0”, no Short Circuit Recovery Sequence is performed. In either case the DFET remains off until the MCU resolves the issue and enables it.

See “Load Detection” on page 54 for more details.

### 6.19 CFET and DFET Pins (50, 51)

The CFET and DFET pins are driven above pin VBAT2 by the charge pump when enabled, which turns on the power FETs. These two pins are analog outputs and should not be driven by an external source. The power FETs can be arranged in either series or parallel configuration, see “0x0E.3 CPWR” on page 53.

Various conditions control the on and off state of these pins. The first group of conditions always applies. They turn off and keep off CFET and DFET and they stop and prevent starting System Scans:

- **Chip Reset:** POR, “RESET Pin (38)” is pulled low, set “0x01.7 Soft Reset”, or set “0x01.6 Reset to IDLE”.
- **System Mode:** SHIP or LOW POWER.
- **Asserted Fault(s):** “0x63.2 DSCF” OR “0x63.5 IOTF” OR “0x63.6 OWF” OR “0x63.7 VCCF” OR “0x65.5 CPMP NRDY” OR “0x67.2 IREG1” OR “0x67.0 VTMPF”.

In SCAN mode, the following group of conditions applies when “0x0E.3 CPWR” on page 53 bit is set to “0” for series connected power FETS. They turn off and keep off CFET and DFET, and inhibit System Scans when they are set to “1”:

If “0x67.6 CHRGI” AND “0x0E.2 FCDC” AND “0x63.4 COCF”  
 If “0x67.7 DCHRGI” AND “0x0E.7 CFD” AND “0x63.3 DOCF”  
 If “0x24.3 VBATICON” AND {[CHRGI AND VBOVF] OR [DCHRGI AND VBUVF]}  
 If “0x24.2 ETA Connect” AND  
 {(DCHRGI AND [DUT1 OR DUT0 OR DOT1 OR DOT0])  
 OR  
 (CHRGI AND [CUT1 OR CUT0 OR COT1 OR COT0])}  
 If “0x24.4 CELLCON” AND  
 {DVCF OR {[CHRGI AND NOT(CHRWUV)} OR DCHRGI] AND UVF  
 OR  
 [{DCHRGI AND NOT(DCHRWUV)} OR CHRGI] AND OVf}

See “DFET Pin (50)” and “CFET Pin (51)” for the cases of when CPWR is set to “1” for parallel power FET applications. See Figure 103 for the shutdown sequence for these pins.

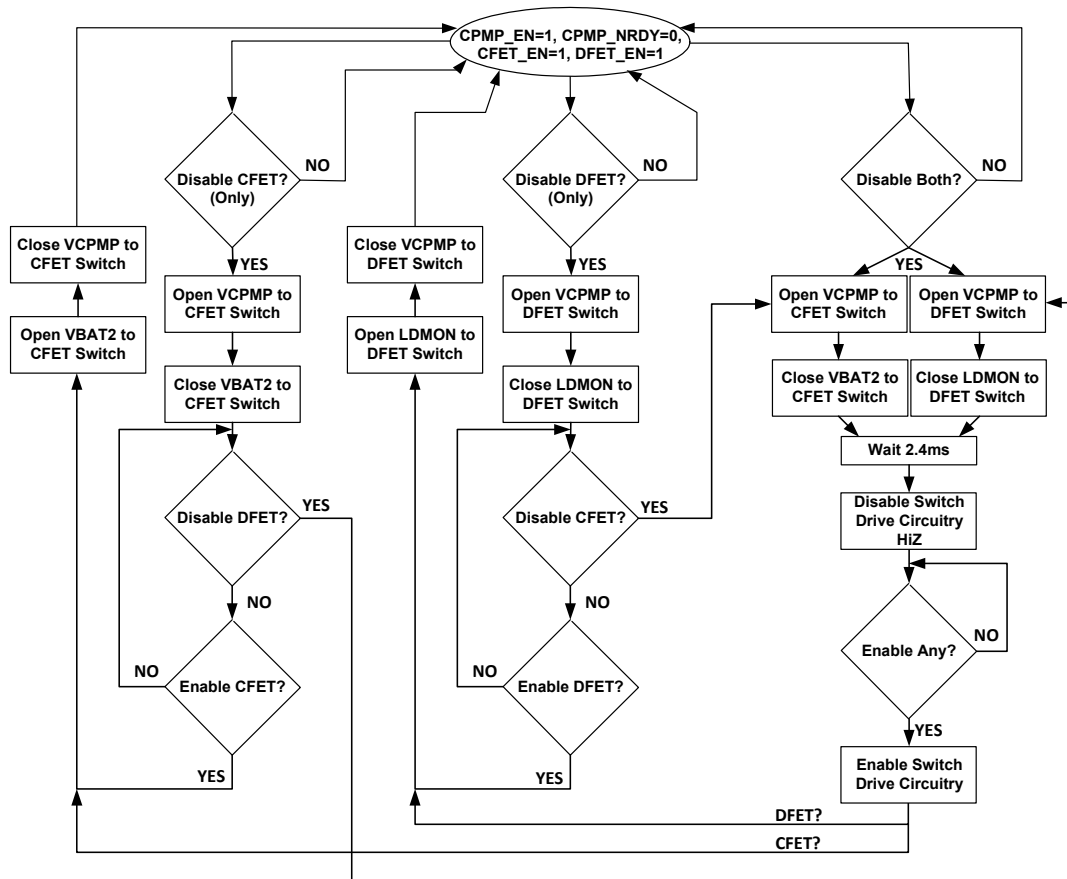

Figure 103. C/DFET Shutdown Flowchart

### 6.19.1 DFET Pin (50)

The DFET pin is the voltage driver output designed to pull the discharge FET gate to about 11V above the pack voltage to turn the device on to supply power to the load. A 1kΩ isolation resistor is recommended between this pin and the DFET gate (Figure 102). Use back-to-back gate-to-source Zener diodes (not pictured) to limit the FET gate-to-source voltage and transient induced currents at the DFET pin. Connect a large value resistor (~1MΩ) between the gate and source of the DFET. The resistor prevents the FET from turning on while in SHIP or LOW POWER mode, or when both power FETs are off.

When both power FETs are being shut off, an internal switch that connects the DFET pin to the LDMON pin is closed for 2.4ms to discharge the gate to source capacitance to shut off the discharge FET. Next, the DFET pin is set to high impedance. If only DFET is shut off, then the switch remains closed.

If the CPWR bit is set to “1” for parallel connected power FETS (separate charge and discharge paths) and any of the following conditions evaluate as “True” in SCAN mode, they cause only DFET to shut off and prevent turning it “On”.

If “0x25.3 IEOC EN” AND “0x66.4 VEOC”

If “0x0E.7 CFD” AND “0x67.7 DCHRG1” AND “0x63.3 DOCF”

If “0x24.3 VBAT1CON” AND DCHRG1 AND “0x65.6 VBUVF”

If “0x24.4 CELLCON” AND {DVCF OR UVF OR [NOT(DCHRWOV) AND OV]}

If “0x24.2 ETA Connect” AND (DCHRG1 AND [DUT1 OR DUT0 OR DOT1 OR DOT0])

### 6.19.2 CFET Pin (51)

The CFET pin is the voltage driver output designed to pull the charge FET gate to about 11V above the pack voltage to turn the device on to supply power to the battery pack. A 1kΩ isolation resistor is recommended between this pin and the CFET gate (Figure 102). Use back-to-back gate-to-source Zener diodes (not pictured) to

limit the FET gate to source voltage and transient induced currents at the CFET pin. Connect a large value resistor (~1MΩ) between the gate and source of the CFET. The resistor prevents the FET from turning on while in SHIP or LOW POWER mode, or when both power FETs are off.

When both power FETs are being shut off an internal switch that connects the CFET pin to the VBAT2 pin is closed for 2.4ms to discharge the gate to source capacitance to shut off the charge FET. Next, the CFET pin is set to high impedance. If only CFET is shut off, then the switch remains closed.

If CPWR bit is set to “1” for parallel connected power FETS (separate charge and discharge paths) and any of the following conditions evaluate as “True” in SCAN mode, they cause only CFET to shut off.

If “[0x0E.2 FCDC](#)” AND “[0x67.6 CHRGI](#)” AND “[0x63.4 COCF](#)”

If “[0x24.3 VBATICON](#)” AND [CHRGI AND VBOVF]

If “[0x24.4 CELLCON](#)” AND {DVCF OR OVF OR [NOT(CHRWUV) AND UVF]}

If “[0x24.2 ETA Connect](#)” AND (CHRGI AND [CUT1 OR CUT0 OR COT1 OR COT0])

The following condition shuts off CFET in SCAN mode in association with the completion of battery charging and is not a function of the CPWR bit:

{(VEOC AND NOT[IEOC EN]) OR (VEOC AND IEOC AND IEOC EN)}

## 6.20 VCPMP Pin (52)

The VCPMP pin is the charge pump output connection to the charge pump capacitor, which is connected between the VCPMP pin and VBAT2 pin. A charge pump capacitor value of approximately 20 times the sum of the gate capacitance of the CFET and DFET is recommended. The capacitor should be placed close to the ISL94216 pins as shown in [Figure 104](#).

The VCPMP pin is an analog output and should not be driven by an external source.

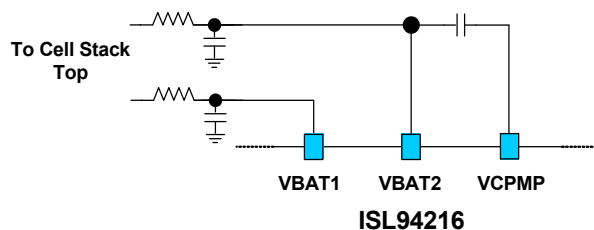

Figure 104. VBAT1, VBAT2 and VCPMP Connections

The charge pump is enabled with bit “[0x24.7 CPMP EN](#)” on [page 70](#) and its status is indicated by bit “[0x65.5 CPMP NRDY](#)” on [page 83](#). See “[Charge Pump](#)” on [page 118](#) for a detailed description of the charge pump state machine.

## 6.21 VBAT2 Pin (53)

VBAT2 is a battery power input to the ISL94216. It provides power to the internal charge pump, gate drivers, load monitor, and cell balancing. This pin is connected internally to the CFET pin when CFET is OFF.

A filter consisting of a 200Ω resistor along with a 1.0μF capacitor to DGND is recommended between this pin and the top of the cell stack as shown in [Figure 104](#). The low side of the charge pump capacitor also connects to this pin. These capacitors should be placed close to the ISL94216 pins.

The connection to the cell stack should be routed to the battery pack separately from the high current load path to minimize any transient effects.

## 6.22 VBAT1 Pin (54)

VBAT1 is a battery power input to the ISL94216. It provides power to the regulators, reference, and the  $V_{CELL}$  multiplexer. Strong or Weak regulators drive the VDD pin depending on the ISL94216 operating mode. For more information, see [“Regulator Measurements and Detectors” on page 62](#).

The  $V_{PACK}$  voltage is measured at the VBAT1 pin by way of a resistor divider. The total resistance for the VBAT1 resistor divider is  $R_{VBAT1}$  on [page 16](#).

A filter consisting of a 200 $\Omega$  resistor along with a 1.0 $\mu$ F capacitor to DGND is recommended between this pin and the top of the cell stack as shown in [Figure 104](#). Place the capacitor close to the VBAT1 pin.

The connection to the cell stack should be routed to the battery pack separately from the high current load path to minimize any transient effects.

## 7. System Operation

The ISL94216 is an integral part of a Battery Management System (BMS) providing a variety of operational modes and functions useful in a wide range of applications.

[Figure 105 on page 103](#) is a flow diagram that illustrates the top level interactions between modes. Additional flow diagrams tie all the individual sections together.

### 7.1 0x2E Scan Operation

The Scan Operation register must be set before triggering a single or continuous System Scan.

**Table 72. 0x2E Scan Operation**

Bits	D[7:6]	D[5:3]	D[2:0]
Bit Name	System Mode	Low Power Timer	Scan Delay
Default	00	01 1	011

#### 7.1.1 0x2E.7:6 System Mode

The System mode bits force the ISL94216 into a specific mode. If a scan or an open-wire test is executing, the mode change waits until they complete before transitioning to the new mode. Cell balancing is interrupted (stopped) by a mode change instruction without a delay.

**Table 73. SM Mode**

D[7:6]	SM Mode
00	IDLE mode
01	SCAN mode
10	LOW POWER mode
11	SHIP mode

Select SCAN mode after all relevant settings have been written. Some changes may be ignored by the ISL94216 if made during an active System Scan.

#### 7.1.2 0x2E.5:3 Low Power Timer

The Low Power Timer bits control the number of consecutive System Scans with a zero current reading (between  $\pm 200\mu\text{V}$ , +19, and -20 decimal register value) that causes the ISL94216 to transition from SCAN mode to LOW POWER mode. The format and default values of the Low Power Timer bits are displayed in [Table 74](#). These bits must be set before triggering a single or continuous System Scan.

**Table 74. Low Power Timer**

Delay: D[5:3]			Number of Scans
0	0	0	OFF
0	0	1	512
0	1	0	1024
0	1	1	2048
1	0	0	4096
1	0	1	8192
1	1	0	16384
1	1	1	32768

#### 7.1.3 0x2E.2:0 Scan Delay

The Scan Delay bits of the Scan Operation register control the delay time between finishing a System Scan measurement/test/cell balancing sequence in continuous scan mode and starting a new one. After a System Scan has completed all measurements, tests, and cell balancing, a delay set by the Scan Delay bits occurs before

starting the next System Scan. These bits have no effect when a single System Scan is triggered. The format and default values of the Scan Delay bits are displayed in [Table 75](#). These bits must be set before triggering a continuous System Scan.

**Table 75. Scan Delay**

Delay: D[2:0]			Delay (ms)
0	0	0	0
0	0	1	64
0	1	0	128
0	1	1	256
1	0	0	512
1	0	1	1024
1	1	0	2048
1	1	1	4096

## 7.2 System Modes

Reset has the highest priority and is initiated by either a  $\overline{\text{RESET}}$  assertion, a  $V_{\text{BAT1}}$  voltage lower than  $V_{\text{POR}}$  (a POR event), a Reset to Idle ([“0x01.6 Reset to IDLE” on page 40](#)), or a Soft Reset ([“0x01.7 Soft Reset” on page 40](#)). The Reset function interrupts any action the ISL94216 is performing.

The second priority is a Discharge Short-Circuit fault ([“0x63.2 DSCF” on page 80](#)). It interrupts any action the device is performing. DFET and CFET automatically turn off and short-circuit recovery begins if the bit [“0x0E.4 ELR” on page 53](#) is “1”. The device transitions to IDLE mode if it is in a different mode.

After power-up, the default mode is IDLE. An MCU command can change the mode of the IC from the current mode to the desired mode (SM mode bits [“0x2E.7:6 System Mode” on page 101](#)). If a measurement or Open-Wire test is executing, the mode change happens when those complete. Cell balancing is interrupted (stopped) by a mode change without a delay.

If a command is not received by the ISL94216 for  $t_{\text{COM}}$  ([page 17](#)) while in IDLE mode, the device transitions to LOW POWER mode unless bit [“0x1F.1 Communication Timeout EN” on page 67](#) is “0”.

A  $\overline{\text{WAKEUP}}$  assertion forces the mode to change to IDLE if in LOW POWER or SHIP mode. It does not force a mode change if in SCAN mode.

If in SCAN mode without a load or charge current ( $|I_{\text{PACK}}| < I_{\text{Zero\_THR}}$  [page 14](#)) for a number of System Scans set by [“0x2E.5:3 Low Power Timer” on page 101](#), the device transitions to LOW POWER mode.

SCAN mode exits to IDLE mode for short circuit or low VCC faults.

If in LOW POWER mode and a load is detected with bit [“0x0E.1 LDLP” on page 54](#) set to “1”, the mode changes to IDLE mode.

Bad Clock (Oscillator) and Power Faults (VDD/VCC, or V2P5 regulators) cause a transition to SHIP mode.

[Figure 105](#) illustrates the mode changes initiated by the ISL94216 or by the Master.

The various system modes are described in more detail in [“SHIP Mode” on page 103](#), [“LOW POWER Mode” on page 104](#), [“IDLE Mode” on page 104](#), and [“SCAN Mode” on page 105](#).

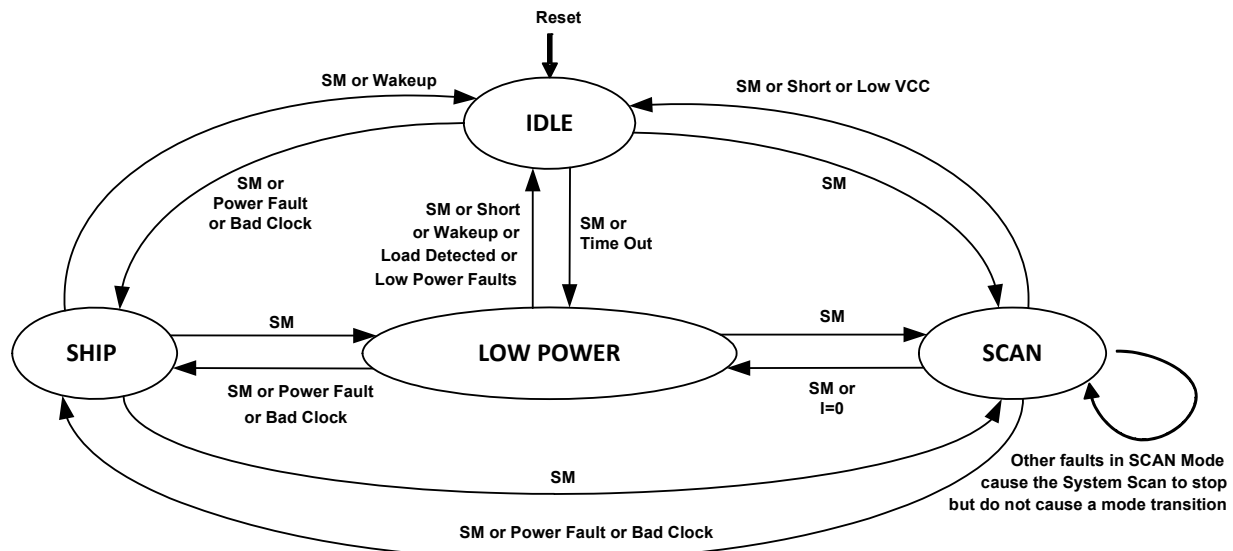

Figure 105. Top Level Flow Diagram of the ISL94216

### 7.2.1 SHIP Mode

SHIP mode is the lowest power mode of the ISL94216. It is entered by changing the SM mode bits ([“0x2E.7:6 System Mode” on page 101](#)) to SHIP mode. If a fault is detected in the internal clock, VDD/VCC, or V2P5 regulators, the device changes to SHIP mode immediately. These faults take priority and anything in progress is interrupted immediately and is not completed. If ALRT is asserted by these faults, it is released following the transition to SHIP mode (by the  $t_{REGSW}$  timer, [page 16](#)) to save power.

The Busy bit ([“0x01.2 Busy” on page 40](#)) is set during the transition to SHIP mode. All functional blocks are powered down except the Strong regulator (see [“0x1B.1 LP REG” on page 64](#)) and timer. First CFET and DFET, cell balancing, open-wire checks, and any measurements are shut off. Those functions remain disabled in SHIP mode. The  $t_{REGSW}$  timer is started to allow time for the MCU to transition to a low power state. When the timer expires, the oscillator is turned off along with the power-good comparators, FET drivers and the charge pump. The Strong regulator is shut off if the LP REG bit is “0”. The Busy bit is cleared. The regulator function is switched to the Weak regulator unless the LP REG bit is “1”, which enables the Strong regulator during LOW POWER and SHIP Modes.

The [“Single Wire Interface” on page 133](#) requires a fast clock. If Single Wire communication occurs in SHIP mode or LOW POWER mode with LP REG bit set to 0, the oscillator is enabled to process the serial transaction. No oscillator fault checks ([“0x67.3 Other Faults” on page 88](#)) occur during serial transaction(s) while in SHIP mode. After the Single Wire transaction is complete, the oscillator is disabled again.

While in SHIP mode the IC does nothing but wait for a  $\overline{WAKEUP}$  or a  $\overline{RESET}$  assertion or a change mode command. All reads or writes that do not access the Scan Operation register ([“0x2E Scan Operation” on page 101](#)) return a NACK.

When  $\overline{WAKEUP}$  or  $\overline{RESET}$  are asserted or a change mode command is received, circuitry is enabled in a specific sequence:

Set Busy Bit → Oscillators → Strong Regulator → Power-Good comparators (VDD, VCC, V2P5) → Oscillator Fault Monitor → Power-Good State Machine → Wait a few milliseconds for “Power-Good” → Read Fuse Bits (if  $\overline{RESET}$ ) → Cal ADC Single Ended Path → Charge Pump (if enabled).

The rest of the pack settings are restored and all faults and indicators are cleared.

If the Power-Good state machine determines that the power is not good while loading register defaults during initialization after a power up or  $\overline{RESET}$  event, the device completes loading and then transitions to SHIP mode. If the power-good state machine determines that the power is not good at any other time, then the device immediately transitions to SHIP mode.



The Busy bit is cleared when the mode transition completes. From  $\overline{\text{RESET}}$  rising edge or from VPOR (page 18), it takes about  $t_{\text{StartUp}}$  (<20ms, page 18) typically to complete the transition to IDLE.

### 7.2.2 LOW POWER Mode

LOW POWER mode includes some measurements and enables timers. This mode is entered manually by changing the System mode bits (“0x2E.7:6 System Mode” on page 101) or automatically by consecutive current readings below  $I_{\text{Zero\_THR}}$  (page 14) during continuous System Scans (“0x2E.5:3 Low Power Timer” on page 101), or no communication from the MCU for  $t_{\text{COM}}$  (page 17) while in IDLE mode unless bit “0x1F.1 Communication Timeout EN” on page 67 is clear.

The Busy bit (page 40) is set during the transition to LOW POWER mode. All functional blocks are powered down except the “Strong” regulator and the  $t_{\text{REGSW}}$  timer which is started. After the timer expires, power switches to the “Weak” regulator only if bit “0x1B.1 LP REG” on page 64 is “0”. The oscillator remains on so the “0x54 - 0x57  $I_{\text{PACK}}$  Timer (R)” on page 46 is operational. The Busy bit is cleared.

While in LOW POWER mode, every  $t_{\text{LPMEAS}}$  period (page 17) relevant circuitry (including the Strong regulator) is powered up to measure  $V_{\text{VCC}}$ ,  $I_{\text{REG}}$ ,  $V_{\text{TEMP}}$ ,  $\text{ETAUX}$ , and  $V_{\text{BAT1}}$ .  $I_{\text{REGOC2}}$  is the  $I_{\text{REG}}$  over-current limit in LOW POWER mode.

All control registers can be written to and read from while in LOW POWER mode. The measurement registers are not updated but the measurement results are compared to limits. After measurements complete, if an unmasked fault is detected and  $\overline{\text{ALRT}}$  is asserted, the regulator remains on. Fault delay counters are not active in LOW POWER mode; single threshold violations trigger faults. A Fault causes the part to change to IDLE mode if  $\overline{\text{ALRT}}$  is asserted. Status  $\overline{\text{ALRT}}$  assertions from the unmasking of Busy and/or CPMP NRDY bits do not cause a transition to IDLE mode. When the device exits LOW POWER mode, the last measurement values are passed to the measurement registers before entering IDLE or SCAN mode.

The “Single Wire Interface” on page 133 requires a fast clock. If Single Wire communication occurs in SHIP or LOW POWER mode with the LP REG bit set to 0, the oscillator is enabled for the duration of the communication, but the device does not check for oscillator faults (“0x67.3 Other Faults” on page 88).

When  $\overline{\text{WAKEUP}}$  or  $\overline{\text{RESET}}$  are asserted, a load connection is detected, or a change mode command is received, the strong regulator is powered up and the Busy bit is set. If bit “0x24.7 CPMP EN” is set, the charge pump circuitry starts. The rest of the pack settings are restored and all faults and indicators are cleared. The Busy bit is cleared when the IC completes the transition to IDLE mode.

Load Connection Detection in LOW POWER mode requires bit “0x0E.1 LDLP” on page 54 to be set to “1” and “0x24.1 DFET EN” to be clear (“0”). Load detection is described further in “0x0E.6:5 ELD” on page 52, “LDMON Pin (49)” on page 96, and “Load Detection” on page 54.

**Note:** If a fault is detected, the strong regulator remains on to allow the  $\overline{\text{ALRT}}$  pin to be driven. The measurement registers are not refreshed until the mode is changed to SCAN or IDLE.

### 7.2.3 IDLE Mode

IDLE mode is entered by changing the SM mode bits (“0x2E.7:6 System Mode” on page 101) to IDLE mode or asserting  $\overline{\text{RESET}}$ . A load detection changes the mode to IDLE if in LOW POWER mode and bit “0x0E.1 LDLP” on page 54 is enabled. If in SCAN mode and a DSCF or VCCF fault is detected, the mode changes to IDLE. Asserting the  $\overline{\text{WAKEUP}}$  pin in LOW POWER or SHIP mode also causes the mode to transition to IDLE.

Delay counters are disabled in IDLE mode. For example, a  $V_{\text{BAT1}}$  overvoltage reading would be passed to the VBOVF bit (“0x65.7 VBOVF” on page 83) without requiring consecutive faulty readings.

Zero current can be read indefinitely in this mode. The Low Power Timer (“0x2E.5:3 Low Power Timer” on page 101) is disabled in IDLE mode.

Commands from the MCU are executed while in IDLE mode.

No communication from the MCU for  $t_{\text{COM}}$  (page 17) leads to a transition to the LOW POWER mode unless bit “0x1F.1 Communication Timeout EN” is “0”.



Current direction indicator bits (“0x67.7 DCHRG1” and “0x67.6 CHRGI”) are disabled in IDLE mode. Fault reaction is therefore limited and does not disable the power FETs. All external thermistor fault thresholds (“ETAUX Detectors”) are applied regardless of current direction.

### 7.2.4 SCAN Mode

SCAN mode is entered by changing the SM mode bits (“0x2E.7:6 System Mode” on page 101) to SCAN mode. All delay counters are cleared when entering SCAN mode.

Faults DSCF, IOTF, OWF, VCCF, CPMP NRDY, IREG1, and VTMPF will halt and prevent continuous System Scan from starting (see “Scan Will Not Start” on page 111).

SCAN mode executes system measurement scans as a single pass or continuously following a trigger (“System Scan Sequence” on page 105). The type of System Scan (single or continuous) is determined by the setting of bit “0x01.1 Scan Select” on page 40. Continuous System Scan can be paused without exiting SCAN mode by setting the System Scan Select bit to “1” for single Scan.

Some faults, too many current readings below  $I_{Zero\_THR}$  (see “0x2E.5:3 Low Power Timer”), or a RESET causes an exit from SCAN to IDLE mode. Fault reaction is immediate for some faults while others wait until measurement completes. See the individual fault descriptions for details. Setting the “0x01.7 Soft Reset” on page 40 or “0x01.6 Reset to IDLE” on page 40 bits causes a transition from SCAN mode to IDLE mode.

#### 7.2.4.1 System Scan Sequence

A System Scan is a sequence of tests that can be executed when the ISL94216 is in SCAN mode. This mode is normally used to monitor the system during charge and discharge operation. The device includes a variety of settings that allow the user wide flexibility in choosing how often and what is monitored. Figure 106 is a simplified state diagram that highlights the sequence and options which are described in the following subsections. Fault and measurement gating bits have been omitted.

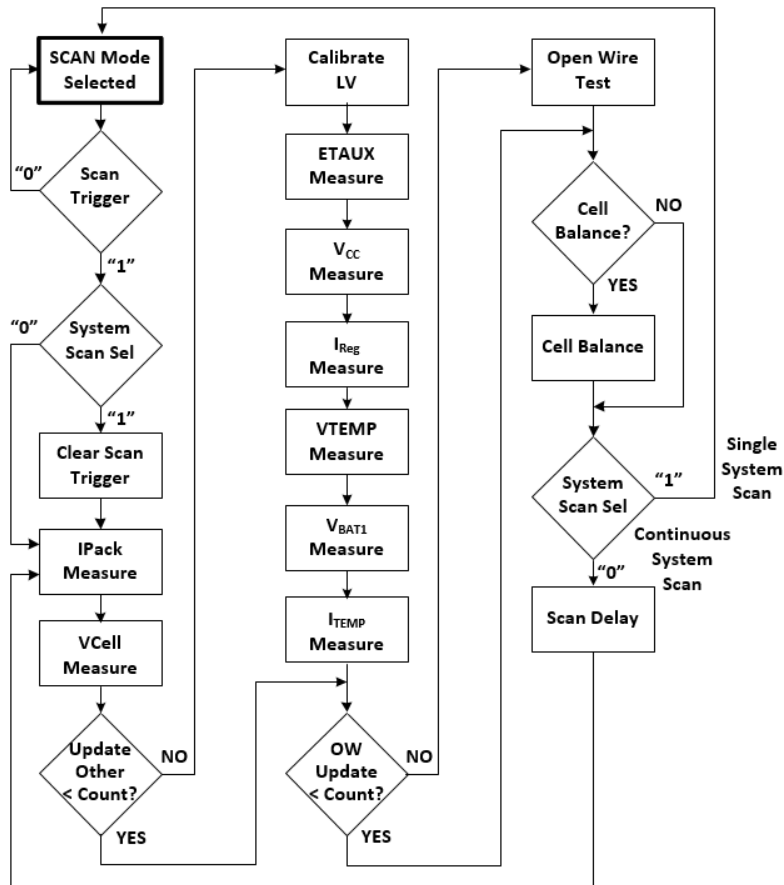

Figure 106. Simplified System Scan

#### 7.2.4.2 SCAN Mode Selected

SCAN mode is selected by setting the bits [“0x2E.7:6 System Mode”](#) of the System Operation register to “01”. After the master selects SCAN mode the ISL94216 moves from the previous mode to this point and waits for a [“0x01.0 System Trigger”](#) to begin a System Scan.

All control bits and registers that determine what is measured, how frequently it is measured, and if the results affect CFET and DFET operation must be set before the assertion of a System Trigger. This includes Mask Bits that gate Fault assertions of the  $\overline{\text{ALRT}}$  pin. These bits and registers are listed in the following sections as they become relevant and all must be determined before the master sends the “Trigger”.

All continuous System Scan loop counters are initialized (see [“0x1B.5:4 Update Other”](#), [“0x03.6:5 OW Update”](#), and [“0x03.1 I<sub>DJR</sub> Delay”](#)). The initial state of the counters is such that all selected tests and measurements associated with them run during the first System Scan during continuous scan.

All fault delay counts are set to “0” when a continuous System Scan is triggered. See [“0x09.3:0 V<sub>CELL</sub> Fault Delay”](#), [“0x09.6 Delta V<sub>CELL</sub> Fault Delay”](#), [“0x09.4 ETAUX Fault Delay”](#), and [“0x09.5 Other Fault Delay”](#).

#### 7.2.4.3 Scan Trigger

A Scan Trigger is required to initiate any single or continuous System Scan. Bit [“0x01.0 System Trigger”](#) must be set to “1” by the master to initiate a System Scan. The type of System Scan (single or continuous) is determined by the setting of bit [“0x01.1 Scan Select”](#).

If a System Trigger is set when any of the fault conditions listed in [“Scan Will Not Start” on page 111](#) is active, it is ignored.

When the System Trigger bit has been received, the Busy bit ([“0x01.2 Busy”](#)) transitions from a “0” to a “1”. If the Busy Mask bit 0x85.0 was cleared before the trigger, then  $\overline{\text{ALRT}}$  pin goes low (see [“0x85 Other Fault Mask”](#)). Using the mask bit and  $\overline{\text{ALRT}}$  pin in this way enables the master to determine when the ISL94216 is making measurements to avoid the possibility of reading stale results.

The Busy bit is reset to “0” when each System Scan ends and it is set to “1” when a new System Scan starts.

#### 7.2.4.4 System Scan Select

Following the System Trigger event the bit setting for [“0x01.1 Scan Select”](#) determines if the triggered System Scan is a single pass or continuously looping System Scan. A setting of “0” enables continuous System Scan and a setting of “1” enables a single System Scan.

If a single System Scan is chosen, the System Trigger bit is cleared before the I<sub>PACK</sub> Measure step in the sequence, otherwise the trigger bit is not cleared.

The System Scan Select bit also determines when a fault response occurs. In single System Scans the fault response occurs at the end of the System Scan sequence. In continuous System Scans the fault response is immediate when the fault thresholds and delays are met. By allowing the System Scan sequence to run to completion in single System Scan the ISL94216 gives the master the option to log status and measurements following a fault detection.

#### 7.2.4.5 I<sub>PACK</sub> Measure

I<sub>PACK</sub> Measurement is gated by the bit [“0x03.7 I<sub>PACK</sub> EN”](#). Setting this bit to “0” disables the measurement and the System Scan sequence moves to the next step. If this bit is set to “1”, then I<sub>PACK</sub> Measurement is enabled and executes.

The ISL94216 connects pins CSP and CSN to the internal ADC and measures the differential voltage based on the setting of register bits [“0x03.4:2 I<sub>PACK</sub> Averages”](#), which sets the number of averages for I<sub>PACK</sub> measurements. The measurement is stored in registers [“0x52 - 0x53 I<sub>PACK</sub> Voltage \(R\)”](#) and the I<sub>PACK</sub> Timer value is stored in registers [“0x54 - 0x57 I<sub>PACK</sub> Timer \(R\)”](#).

A measurement result that exceeds either the [“0x67.7 DCHRG1”](#) or [“0x67.6 CHRGI”](#) thresholds (I<sub>Zero\_THR</sub>, [page 14](#)) sets the related bit. Also see [“0x03.1 I<sub>DJR</sub> Delay”](#) for Continuous Scans.

If the current is between these thresholds for the number of System Scans selected by the bits [“0x2E.5:3 Low Power Timer”](#), the device transitions from SCAN to LOW POWER mode at the end of the sequence.

If the system is discharging, the  $I_{PACK}$  voltage measurement is compared to the [“0x0B DOC Threshold”](#). A [“0x63.3 DOCF”](#) is set if the DOC threshold is exceeded for the consecutive number of System Scans set by [“0x0D OC Delay”](#).

If the system is charging, then  $I_{PACK}$  voltage measurement is compared to the [“0x0F COC Threshold”](#). A [“0x63.4 COCF”](#) is set if the COC threshold is exceeded for the consecutive number of System Scans set by COC Delay ([“0x0D OC Delay”](#)).

If the battery is charging with [“0x25.3 IEOC EN”](#) and [“0x25.6 Auto CB EN”](#) both set to “1”, and the CFET is “On”, the  $I_{PACK}$  voltage measurement is compared to the [“0x10 IEOC Threshold”](#) to determine if the battery is full. See [“Automatic Cell Balancing” on page 115](#) for more information.

Any faults propagate to the  $\overline{ALRT}$  pin if the associated mask bits are clear.

Timing of a fault response to DOCF or COCF is determined by [“System Scan Select” on page 106](#). The action taken by the ISL94216 is controlled by register [“0x0E Load/Charge Operations” on page 52](#). Set bit [“0x0E.7 CFD” on page 52](#) to “1” to enable shut off of power FETs due to a DOCF. Set bit [“0x0E.2 FCDC” on page 53](#) to “1” to enable shut off of power FETs due to a COCF. The setting of the configuration bit [“0x0E.3 CPWR” on page 53](#) determines if both power FETs are shut off in a series configuration or an individual FET is shut off in a parallel configuration. System Scan stops when the FETs are shut off in a series configuration.

A DSCF fault is not dependent on  $I_{PACK}$  measurements and always stops System Scans shutting off CFET and DFET. See [“0x63.2 DSCF” on page 80](#).

#### 7.2.4.6 $V_{CELL}$ Measure

$V_{CELL}$  Measurement is gated by the bit [“0x02.7  \$V\_{CELL}\$  EN”](#). A “0” setting disables this measurement and the System Scan sequence moves to the next step.

The ISL94216 first connects pins VC1 and VC0 to the internal ADC and measures the differential voltage based on the setting of register bits [“0x02.4:2  \$V\_{CELL}\$  Averages”](#), which sets the number of averages for  $V_{CELL}$  measurements. The MUX sequentially connects each enabled cell, per registers [“0x04 - 0x05 Cell Select”](#), until all are measured. The results are stored in registers [“0x30 - 0x4F  \$V\_{CELL}\$  Voltage \(R\)”](#). The difference between the highest and lowest cell voltages is calculated and stored in register [“0x50 - 0x51  \$V\_{CELL}\$  Max Delta Voltage \(R\)”](#).

If any  $V_{CELL}$  voltage measurement is greater than 0x06  $V_{CELL}$  Overvoltage or less than 0x07  $V_{CELL}$  Undervoltage thresholds ([“0x06 - 0x07  \$V\_{CELL}\$  OV/UV Threshold”](#)), then a fault is set. A [“0x63.0 OVF”](#) is set if the  $V_{CELL}$  OV threshold is exceeded for the consecutive number of System Scans set by  $V_{CELL}$  Delay ([“0x09.3:0  \$V\_{CELL}\$  Fault Delay”](#)). If any  $V_{CELL}$  voltage drops below the  $V_{CELL}$  UV threshold for more System Scans than the  $V_{CELL}$  Delay setting, then fault [“0x63.1 UVF”](#) is set. These faults propagate to the  $\overline{ALRT}$  pin if the associated mask bits are clear (see [“0x83 Priority Fault Mask”](#)).

The  $V_{CELL}$  Max Delta Voltage is compared to [“0x08  \$V\_{CELL}\$  Max Delta Threshold”](#) and if the threshold is exceeded for more System Scans than the setting [“0x09.6 Delta  \$V\_{CELL}\$  Fault Delay”](#), fault [“0x66.3 DVCF”](#) is set. This fault propagates to the  $\overline{ALRT}$  pin if the associated mask bit is clear (see [“0x86 CB Status Mask”](#)).

Timing of the fault response to  $V_{CELL}$  OV/UV and/or DVCF is determined by [“System Scan Select” on page 106](#). The action taken by the ISL94216 is controlled by register bit [“0x24.4 CELLCON”](#). This bit must be set to “1” to allow  $V_{CELL}$  faults to shut off the power FETs. With CELLCON set to “1” an OVF, UVF, or DVCF shuts off both power FETs and stops System Scans.

The lowest cell voltage is compared to the [“0x2B CBMAX Threshold”](#) and bit [“0x66.2 2HI2CB”](#) is set if all cell voltages are greater than this threshold.

The highest cell voltage is compared to the [“0x2C CBMIN Threshold”](#) and bit [“0x66.1 2LO2CB”](#) is set if all cell voltages are less than this threshold.

The bit [“0x66.0 Need CB”](#) is set when the difference between one or more of all the measured cell voltages, and the minimum of all of them is greater than the [“0x2A CB Min Delta Threshold”](#).

If Auto CB EN is set to “1”, then [“0x26-27 CB Cell State”](#) shows the cells automatically determined by the chip to need cell balancing. The ISL94216 finds the minimum of all the cell voltages and calculates the difference between each cell voltage and the minimum. The CB CELL STATE bit is 1 for cells in which the calculated difference is higher than [“0x2A CB Min Delta Threshold”](#). The CB CELL STATE bit is 0 for other cells.

The bit [“0x66.4 VEOC”](#) is set if at least one cell voltage measures above the [“0x2D VEOC Threshold”](#).

For constant current charging with bits [“0x25.1 CB EOC”](#) and [“0x25.3 IEOC EN”](#) both set to “0”, [“0x66.7 BAT FULL”](#) sets when the VEOC bit (0x66.4) is set.

If bit CB EOC is set to “1” and bit IEOC EN is set to “0”, then BAT FULL sets when VEOC changes from “0” to “1” and then all cell voltages drop  $V_{CBHys}$  ([page 16](#)) below the VEOC threshold.

For constant voltage charging with CB EOC set to “0” and the IEOC EN bit set to “1”, [“0x66.7 BAT FULL”](#) sets after the highest cell voltage reaches the VEOC threshold (the VEOC bit is set) and the IEOC bit (0x66.5) sets due to the charge current dropping below the [“0x10 IEOC Threshold”](#).

#### 7.2.4.7 Update Other

If a single scan is triggered (0x01.1 System Scan Select set to “1”), or this is the first iteration of continuous System Scan, the sequence moves to the next step “Calibrate LV”. Otherwise the next step is determined by the Update Other setting.

Register bits [“0x1B.5:4 Update Other”](#) set the number of System Scans required to trigger system measurements beyond  $I_{PACK}$  and  $V_{CELL}$ . If the ISL94216 has completed a number of System Scans equal to the Update Other setting, then Scan counter is cleared and the sequence steps to “Calibrate LV”, otherwise the sequence steps to [“Open-Wire Test”](#).

#### 7.2.4.8 Calibrate LV

This step executes an internal calibration of the ADC/MUX path used for the ETAUX, VCC, VTEMP, VBAT1, and ITEMP measurements. It is followed by the ETAUX Measure step.

#### 7.2.4.9 ETAUX Measure

ETAUX Measure is gated by bits [“0x11.7:6 ETAUX Enable”](#). Set these bits to “0” to disable the measurement and move the sequence to the next step. If either or both bits are set to “1” the corresponding measurement is enabled and executes. The following description assumes both bits are set to “1” and the pins are connected to 10kΩ NTC thermistors as shown in [Figure 99 on page 92](#).

Bit [“0x09.7 AUX/xTn Pull-Up”](#) should be disabled with a setting of “0” before starting either type of System Scan. The pull-up is intended for open-wire test of the ETAUX pins. If it is enabled during the ETAUX measurement results can be slightly higher (indicating a lower temperature). See [“Aux Pins Open-Wire Test”](#).

Bits [“0x11.4:2 ETAUX Averages”](#) set the number of averages for each AUX pin measurement. If AUX0/xT0 is enabled (0x11.6 = “1”) the ADC measures its voltage relative to VSS. AUX1/xT1 is measured next if enabled (0x11.7 = “1”). The results are stored in registers [“ETAUX Detectors”](#).

The results are next compared to thresholds for fault detection (see [“0x13-1A ETAUX Thresholds”](#)). When the device is charging ([“0x67.6 CHRGI”](#) is “1”), the measurement is compared to the CUTn and COTn thresholds (n = 0 and 1). While discharging ([“0x67.7 DCHRGI”](#) is “1”), the measurement is compared to the DUTn and DOTn thresholds. If the device is neither charging or discharging, the measurement is compared to all thresholds for the measurement pin. Any threshold violation(s) set the related fault bit(s) in register [“0x64 ETAUX Fault”](#). These faults propagate to the ALRT pin if the associated mask bits are clear (see [“0x84 ETAUX Fault Mask”](#)).

Timing of the fault response to an OT or UT fault is determined by [“System Scan Select” on page 106](#). The action taken when a fault is detected is determined by register bit [“0x24.2 ETA Connect”](#). This bit must be set to “1” to allow OT or UT faults to shut off the power FETs. The setting of the configuration bit [“0x0E.3 CPWR”](#) determines if both power FETs are shut off in a series configuration or an individual FET is shut off in a parallel configuration.

#### 7.2.4.10 V<sub>CC</sub> Measure

V<sub>CC</sub> Measure is not gated by an enable bit. It is always executed on the first iteration of continuous System Scan or whenever a single System Scan is triggered. During continuous System Scan subsequent V<sub>CC</sub> measurements are gated by [“0x1B.5.4 Update Other”](#).

V<sub>CC</sub> is measured at the V<sub>CC</sub> pin relative to V<sub>SS</sub>. Bits [“0x1F.4:2 Other Averages”](#) of the V<sub>BAT1</sub> Operation register set the number of readings averaged per measurement before storing the results to register [“0x60 VVCC Voltage \(R\)”](#).

After measurement, the voltage is compared to the threshold register [“0x1C VVCC Min Threshold”](#) and if the comparison fails, the fault bit [“0x63.7 VCCF”](#) is set. Bit [“0x09.5 Other Fault Delay”](#) controls the required number of consecutive faults before action is taken. The fault propagates to the ALRT pin if the associated mask bit is clear (see [“0x83 Priority Fault Mask”](#)).

Timing of the fault response to VCCF is determined by [“System Scan Select” on page 106](#). The fault response is not controlled by a register “Connect” bit. A VCCF shuts off both power FETs. The setting of the configuration bit [“0x0E.3 CPWR”](#) has no effect on V<sub>CC</sub> faults.

#### 7.2.4.11 I<sub>Reg</sub> Measure

I<sub>Reg</sub> Measure is not gated by an enable bit. It is always executed on the first iteration of continuous System Scan or whenever a single System Scan is triggered. During continuous System Scan, subsequent I<sub>Reg</sub> measurements are gated by [“0x1B.5.4 Update Other”](#).

The I<sub>Reg</sub> voltage is a differential measurement across the external sense resistor tied between the EMITTER and VDD pins, as shown in [Figure 100 on page 93](#). Bits [“0x1F.4:2 Other Averages”](#) of the V<sub>BAT1</sub> Operation register set the number of readings averaged per measurement before storing the results to register [“0x61-62 IREG Voltage \(R\)”](#).

This measurement has two thresholds, IREG<sub>OC1</sub> and IREG<sub>OC2</sub> ([“0x1D.1E IREGOC1, 2 Threshold”](#)). When the device is in IDLE or SCAN mode the measurement is compared to IREG<sub>OC1</sub>. In LOW POWER mode the measurement is compared to IREG<sub>OC2</sub>. If the comparison fails, the respective I<sub>Reg</sub> fault bit ([“0x67.2 IREG1”](#) or [“0x67.1 IREG2”](#)) is set. This fault propagates to the ALRT pin if the associated mask bit is clear (see [“0x87 Status Mask”](#)).

Timing of the fault response to I<sub>Reg</sub> Measure is determined by [“System Scan Select” on page 106](#). The fault response is not controlled by a register “Connect” bit. An I<sub>Reg</sub> fault shuts off both power FETs and stops System Scans, regardless of the setting of the configuration bit [“0x0E.3 CPWR”](#).

#### 7.2.4.12 VTEMP Measure

VTEMP Measure is not gated by an enable bit. It is always executed if a single System Scan is triggered or on the first iteration of continuous System Scan. During other iterations of continuous System Scan, its measurement is gated by [“0x1B.5.4 Update Other”](#). The VTEMP voltage is a reference voltage used to pull up the external temperature sensor circuitry (see [Figure 99 on page 92](#)). The Other Averaging bits (see [“0x1F.4:2 Other Averages”](#)) of the V<sub>BAT1</sub> Operation register set the number of samples averaged per measurement before storing the results to register [“0x5F VVTEMP Voltage \(R\)”](#).

The VTEMP voltage has a compare threshold that sets the bit [“0x67.0 VTMPF”](#) if violated. This fault propagates to the ALRT pin if the associated mask bit is clear (see [“0x87 Status Mask”](#)). The VTEMP<sub>Min</sub> threshold limit is in the Electrical Specifications on [page 16](#) and is a fixed value. An VTMPF fault shuts off both power FETs and stops System Scans, regardless of the setting of the configuration bit [“0x0E.3 CPWR”](#).

#### 7.2.4.13 V<sub>BAT1</sub> Measure

V<sub>BAT1</sub> Measure is gated by bit [“0x1F.7 VBAT1 EN”](#). Set this bit to “0” to disable the measurement and move the System Scan sequence to the next step. Set this bit to “1” to enable and execute VBAT Measurement.

The V<sub>BAT1</sub> voltage is measured by the ADC relative to V<sub>SS</sub>. The number of averages for the measurement are set by bits [“0x1F.4:2 Other Averages”](#). The results are stored in registers [“0x5C - 0x5D VBAT1 Voltage \(R\)”](#).



If the  $V_{BAT1}$  voltage measurement is greater than [“0x20 VBAT1 OV Threshold”](#), bit [“0x65.7 VBOVF”](#) is set. If the measurement is less than [“0x21 VBAT1 UV Threshold”](#), bit [“0x65.6 VBUVF”](#) is set. Bit [“0x09.5 Other Fault Delay”](#) controls the required number of consecutive faults before action is taken. VBOVF and VBUVF faults propagate to the  $\overline{ALRT}$  pin if the associated mask bits are clear (see [“0x85 Other Fault Mask”](#)).

Timing of the fault response to  $V_{BAT}$  OV/UV is determined by [“System Scan Select” on page 106](#). The action taken when a fault is detected is determined by register bit [“0x24.3 VBAT1CON”](#). This bit must be set to “1” to allow VBOVF or VBUVF to shut off the power FETs. The setting of the configuration bit [“0x0E.3 CPWR” on page 53](#) determines if both FETs are shut off in a series configuration or an individual FET is shut off in a parallel configuration.

#### 7.2.4.14 $I_{TEMP}$ Measure

Internal Temperature measurement is gated by bit [“0x1F.6 ITEMP EN”](#). Set this bit to “1” to enable measurement of the internal temperature while in SCAN mode. Set this bit to “0” to disable the measurement and move the sequence to the next step.

The ISL94216 connects the internal temperature sensor to the ADC and measures its voltage. Bits [“0x1F.4:2 Other Averages”](#) set the number of averages for  $I_{TEMP}$  measurements. The results are stored in register [“0x5E Internal Temperature \(R\)”](#). The bit [“0x09.5 Other Fault Delay”](#) controls the required number of consecutive faults before action is taken.

If the  $I_{TEMP}$  voltage measurement result is less than the 0x22 IOTW Threshold, a warning bit [“0x66.6 IOTW”](#) is set. If the  $I_{TEMP}$  measurement result is less than the 0x23 IOTF Threshold, fault bit [“0x63.5 IOTF”](#) is set. The warning/fault propagates to the  $\overline{ALRT}$  pin if the associated mask bit is clear (see [“0x86 CB Status Mask”](#) and [“0x83 Priority Fault Mask”](#)). See [“0x22 - 0x23 IOTW and IOTF Thresholds”](#) for information about setting the thresholds.

Timing of the fault response to  $I_{TEMP}$  is determined by [“System Scan Select” on page 106](#), otherwise the action taken by the ISL94216 is not controlled by a register “Connect” bit. An IOTW does not change the status of the power FETs or stop System Scans. An IOTF shuts off both power FETs and stops System Scans regardless of the setting of bit [“0x0E.3 CPWR” on page 53](#).

#### 7.2.4.15 Open-Wire Test

Open-Wire Test is gated by bit [“0x24.6 OW EN”](#). Set this bit to “0” before starting System Scan to disable the test, and the sequence moves to the next step. When enabled, the Open-Wire Test executes if the System Scan counter set by [“0x03.6:5 OW Update”](#) is satisfied.

The results of the open-wire tests are found in locations [“0x68-69 Open-Wire Status”](#), [“0x65.2 OW VBAT1”](#), and [“0x65.1 OW VSS”](#). A “1” at an OW CellIn bit indicates that at least one wire is not connected between the device and the corresponding cell. Bit [“0x63.6 OWF”](#) is the OR'd result of all the open-wire fault bits. The faults for any of the open-wire bits can propagate to the  $\overline{ALRT}$  pin if the associated mask bits are cleared. See [“0x88-89 Open-Wire Mask”](#) and [“0x85 Other Fault Mask”](#).

An OWF shuts off both power FETs and stops System Scans regardless of bit [“0x0E.3 CPWR”](#).

See [“Open-Wire Function” on page 112](#) for a detailed description of the test sequence and options.

#### 7.2.4.16 Cell Balance

Automatic Cell Balancing during a System Scan is gated by bits [“0x25.7 CB EN”](#) and [“0x25.6 Auto CB EN”](#). Set either of these bits to “0” to disable Automatic Cell Balancing and move the sequence to the next step. If both bits are set to “1” Automatic Cell Balancing is enabled and executes per the following settings:

[“0x25.5 CB Configuration” on page 73](#) selects internal or external Cell Balancing FETs.

[“0x25.3 IEOC EN” on page 74](#) selects ending charging with either a voltage or current target.

[“0x25.2 CB Mask” on page 75](#) selects allowing or preventing simultaneous balancing of adjacent cells.

[“0x25.1 CB EOC” on page 75](#) selects allowing or preventing cell balancing after reaching VEOC.

[“0x25.0 CB CHRГ” on page 75](#) selects allowing or preventing cell balancing while charging below VEOC.

[“0x2A CB Min Delta Threshold” on page 76](#) sets the minimum cell voltage difference for cell balancing.

[“0x2B CBMAX Threshold” on page 76](#) sets the maximum cell voltage allowed for cell balancing.

[“0x66.2 2HI2CB” on page 86](#) is set if all cell voltages are greater than CB MAX Threshold.

[“0x2C CBMIN Threshold” on page 77](#) sets the minimum cell voltage allowed for cell balancing.

[“0x66.1 2LO2CB” on page 86](#) is set if all cell voltages are less than CB MIN Threshold.

[“0x2D VEOC Threshold” on page 77](#) sets the maximum cell voltage used to indicate end of (constant current) charge.

[“0x10 IEOC Threshold” on page 78](#) sets the minimum charge current to indicate end of constant voltage charge.

[“0x28, 0x29 Cell Balancing Timers” on page 78](#) sets the balance on and off times.

A thorough review of Sections [“Cell Balancing Registers” on page 73](#) and [“Automatic Cell Balancing” on page 115](#) is recommended to determine application-specific settings.

Cell balancing methods supported by the ISL94216 are detailed in [“Cell Balancing Examples” on page 114](#).

#### 7.2.4.17 Scan Delay

The setting of [“0x2E.2:0 Scan Delay”](#) controls the delay time between finishing a continuous System Scan cycle and starting the next. The Busy Bit ([“0x01.2 Busy”](#)) is cleared at the start of Scan Delay.

#### 7.2.4.18 System Scan Select

The continuous System Scan sequence is completed when the Scan Delay time ends. The bits [“0x01.1 Scan Select”](#) controls whether the System Scan is single or continuously looping. A setting of “0” enables continuous System Scan and a setting of “1” chooses a single System Scan.

If a single System Scan is selected, then the state machine returns to the SCAN mode start point [“System Scan Sequence” on page 105](#) and waits for the next [“Scan Trigger”](#).

If continuous System Scan is selected and no faults occur, then the System Scan counter is incremented and the state machine returns to step [“System Scan Select” on page 106](#) where the next sequence begins (see [Figure 106 on page 105](#)).

The System Scan Select bit also determines when a fault response occurs. For single System Scan, the fault response occurs at the end of the System Scan sequence. In continuous System Scan, the fault response occurs when the fault thresholds and delay counters are met.

### 7.2.5 Scan Will Not Start

System Scan can not start if the ISL94216 is being reset by POR,  $\overline{\text{RESET}}$  held low, or either [“0x01.7 Soft Reset”](#) or [“0x01.6 Reset to IDLE”](#) set to “1”. System Scan only runs in SCAN mode, it can not run in IDLE, LOW POWER or SHIP Modes.

If any of the following bits are set, System Scan may not start and/or stops until the fault is clear:

- [“0x63.7 VCCF” on page 79](#)
- [“0x63.6 OWF” on page 80](#)
- [“0x63.5 IOTF” on page 80](#)
- [“0x63.2 DSCF” on page 80](#)
- [“0x67.2 IREG1” on page 88](#)
- [“0x67.0 VTMPF” on page 88](#)
- [“0x65.5 CPMP NRDY” on page 83](#)

These conditions stop and prevent System Scans if the [“0x0E.3 CPWR”](#) bit is “0”:

[“0x0E.2 FCDC”](#) AND [“0x67.6 CHRGI”](#) AND [“0x63.4 COCF”](#))

OR

[“0x0E.7 CFD”](#) AND [“0x67.7 DCHRG1”](#) AND [“0x63.3 DOCF”](#))

OR

[“0x24.4 CELLCON”](#) AND [“0x66.3 DVCF”](#))

OR

CELLCON AND {[(CHRGI AND NOT[CHRWUV]) OR DCHRG1] AND UVF}

OR

CELLCON AND {[(DCHRG1 AND NOT[DCHRWUV]) OR CHRGI] AND OVf}

OR

[“0x24.3 VBAT1CON”](#) AND [CHRGI AND VBOVF] OR [DCHRG1 AND VBUVF]

OR

[“0x24.2 ETA Connect”](#) AND DCHRG1 AND (DOT0 OR DOT1 OR DUT0 OR DUT1)

OR

ETA CON AND CHRGI AND (COT0 OR COT1 OR CUT0 OR CUT1)

This condition stops and prevents System Scans if the CPWR bit is “1”:

CELLCON AND {DVCF OR (NOT[CHRWUV] AND UVF) OR NOT[DCHRWOV] AND OVf}

For bit descriptions see [“0x63.1 UVF”](#) on page 81, [“0x63.0 OVf”](#) on page 81, [“0x02.5 CHRWUV”](#) on page 42, [“0x02.6 DCHRWOV”](#) on page 42, [“0x64.1 DOT0”](#) on page 82, [“0x64.5 DOT1”](#) on page 82, [“0x64.0 DUT0”](#) on page 83, [“0x64.4 DUT1”](#) on page 82, [“0x64.3 COT0”](#) on page 82, [“0x64.7 COT1”](#) on page 82, [“0x64.2 CUT0”](#) on page 82, [“0x64.6 CUT1”](#) on page 82, [“0x65.7 VBOVF”](#) on page 83, [“0x65.6 VBUVF”](#) on page 83, [“0x67.7 DCHRG1”](#) on page 87 and [“0x67.6 CHRGI”](#) on page 87.

### 7.3 Open-Wire Function

The open-wire function tests for broken connections between the battery cells and the BMS circuit board. A block diagram of the open-wire circuit is shown in [Figure 107](#). The cell open-wire test (VC0 - VC16) checks the wires between the connector and cells (in blue) while VSS and V<sub>BAT1</sub> OW checks the connections in red.

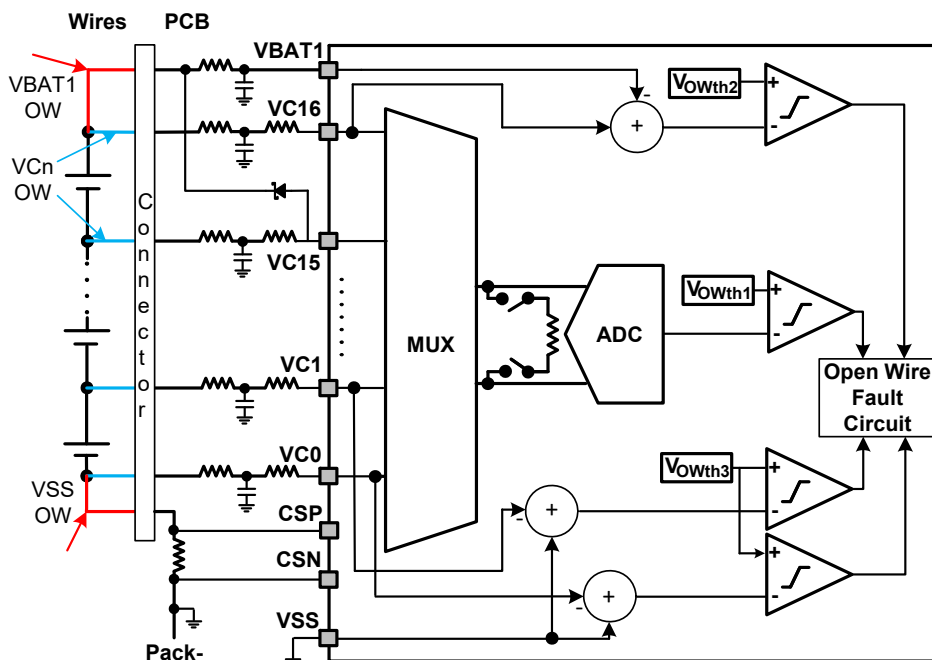

Figure 107. ISL94216 Open-Wire Circuit Block Diagram



An open-wire test can be triggered manually by setting bit [“0x24.5 OW Trigger”](#) to “1” while in IDLE mode. The test is executed automatically during System Scans if bit [“0x24.6 OW EN”](#) is set to “1”. The open-wire test is run on the first and every nth System Scan per the setting of bits [“0x03.6:5 OW Update”](#) during continuous System Scans. If an open-wire fault occurs during a System Scan, the scan stops, DFET and CFET are turned off, and DFET EN and CFET EN are set to “0” (see [“0x24 Power FET Operation”](#)).

An internal resistor is connected across one cell at a time during the open-wire test. The resistor is connected for  $t_{OW}$  ([page 17](#)) across the cell. A cell measurement is performed after  $0.8 \cdot t_{OW}$ . If the voltage reading is less than  $V_{OWth1}$  ([page 17](#)), then at least one of the cell connections is considered open. Open-wire test results are a function of the capacitance connected to the device pins because the voltage across a larger capacitance takes longer to change. The open-wire circuit is designed to tolerate up to  $C_{OW}$  ([page 17](#)) of equivalent capacitance on each pin.

As an example, consider the case when the OW Test resistor is connected between device pins VC5 and VC6. If the measured cell voltage is less than  $V_{OWth1}$ , the connection between the battery and pins VC5 and/or VC6 is likely to be bad. If only one pin has a bad connection, the specific pin can be determined with two open-wire fault bits. If only Cell(n) and Cell(n-1) fail open-wire, the open pin is VC(n-1) because bits OW Cell(n) and OW Cell(n-1) ([“0x68-69 Open-Wire Status”](#)) are set. Open-wire mask bits are in registers [“0x88-89 Open-Wire Mask”](#). If a mask bit is set to “0” and an open is detected on that cell, then the  $\overline{ALRT}$  pin transitions low. Open-wire status of VC0 is tested with VC1 and indicated by the bit for “OW Cell1”.

After all of the cell voltage sense connections have been tested, the pack current is measured. If the current measurement shows that the pack is discharging, then open-wire sequence ends. If in IDLE mode when the exit from open-wire test occurs, the Busy bit is cleared. If the pack is not discharging, then VSS and VBAT1 connections are tested for open-wires before the open-wire sequence ends.

If VSS connection to the bottom cell is made through the pack low-side sense resistor and load current wire ([Figure 107](#)), separate from the VC0 and VC1 voltage sense connections to their respective cells, then an open in the pack ground return connection is detectable. The VSS pin voltage is compared to VC0 and VC1 pins. If  $(VSS - VC0)$  and/or  $(VSS - VC1)$  are greater than  $V_{OWth3}$  ([page 17](#)), the VSS ground return connection is considered open.

If a Schottky diode is connected from VC15 to  $V_{BAT1}$  and the  $V_{BAT1}$  connection to the top cell is made through the pack high-side load current wire, separate from VC15 and VC16 voltage sense connections to their respective cells, then an open in the high side load current connection is detectable. The  $V_{BAT1}$  pin voltage is compared to VC16. If  $(VC16 - V_{BAT1})$  is greater than  $V_{OWth2}$  ([page 17](#)), then the  $V_{BAT1}$  pin connection is considered open.

Open-wire fault indicators for VSS and VBAT1 are located in [“0x65 Other Fault Register”](#) and the mask bits are in [“0x85 Other Fault Mask”](#).

Note the difference between Status bit [“0x67.7 DCHRG1”](#) and internal states “charging”, “discharging”, and “not discharging”. If the current voltage measurement is less than  $-200\mu\text{V}$  (-20 decimal register value), the pack is “discharging”. If the current voltage measurement is greater than  $+200\mu\text{V}$  (+19 decimal register value), the pack is “charging”. If the current voltage measurement is greater than approximately  $-200\mu\text{V}$  (-20 decimal register value), the pack is “NOT discharging”. These internal states are not gated by counters; in Continuous Scan mode bits DCHRG1 and [“0x67.6 CHRGI”](#) are gated by [“0x03.1 I<sub>DJR</sub> Delay”](#).

The open-wire sequence does not include testing the ETAUX pins for open wires. See [“Aux Pins Open-Wire Test” on page 93](#) for a description of the test method.

Voltage measurements done as part of the open-wire test sequence are only used for open-wire detection. They are not stored in registers or used to detect overvoltage or undervoltage faults.

### 7.4 Cell Balancing Examples

Register “0x25 CB Operation” on page 73 controls cell balancing features of the ISL94216. The master must select either Automatic or Manual cell balancing, and the conditions under which balancing occurs.

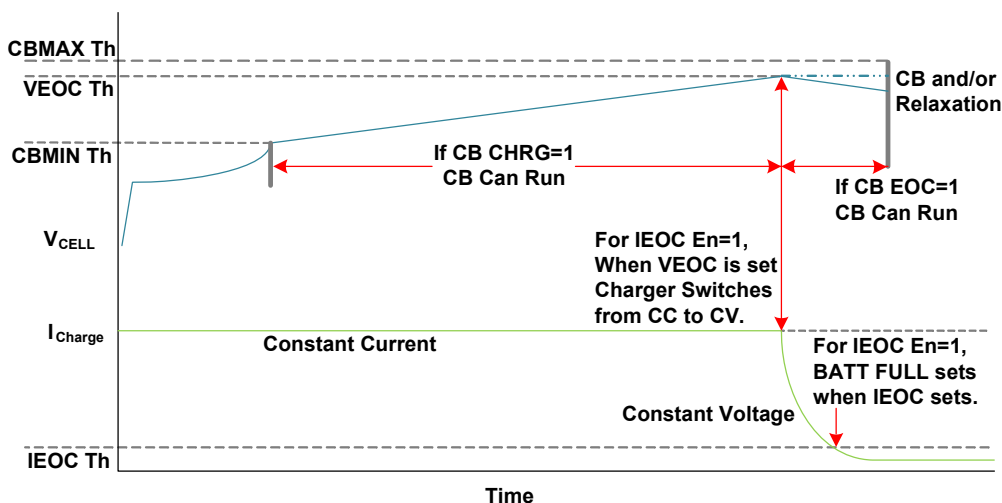

Figure 108. A Typical Charge Characteristic Curve

The ISL94216 has features that support both Constant Current (CC) and Constant Voltage (CV) charging. A typical charging profile for a battery cell is depicted in [Figure 108](#). Cell balancing can occur only when the cell voltage is between the CBMIN and CBMAX limits, which are independent of CB EOC and CB CHRГ bit settings.

The following examples are independent of the choice of internal versus external cell balancing FETs.

### 7.4.1 Automatic Cell Balancing

Bits [“0x25.0 CB CHRG” on page 75](#), [“0x25.1 CB EOC” on page 75](#) and [“0x25.3 IEOC EN” on page 74](#) determine the behavior of automatic cell balancing relative to [“0x2D VEOC Threshold” on page 77](#) and [“0x10 IEOC Threshold” on page 78](#). The behavior of auto cell balancing in relation to these bits and thresholds is summarized in [Table 76](#). This table assumes charging, automatic cell balancing is enabled, cell voltages are between CBMIN and CBMAX, VEOC is less than CBMAX, and at least one cell needs to be balanced.

**Table 76. Auto CB vs Bit Settings**

CB CHRG	IEOC EN	CB EOC	Sequence	Charge Type
1	0	0	Cell balancing starts when a cell needing balancing is greater than CBMIN and less than CBMAX. VEOC sets when the maximum cell voltage is >VEOC threshold, this triggers BATT FULL to set, which stops Cell Balancing, shuts off CFET (and DFET if CPWR = 0) and clears AUTO CB. DFET remains on if CPWR=1.	Constant Current
1	0	1	Cell balancing starts when cell voltages are within ~60mV of the VEOC threshold. VEOC sets when the highest cell voltage is >VEOC threshold and CFET (and DFET if CPWR = 0) shuts off. Cell balancing is applied until all cell voltages fall below VEOC - VCBHys ( <a href="#">page 16</a> ). Next, Cell Balancing stops, the BATT FULL bit is set, and AUTO CB is cleared. DFET remains on if CPWR=1.	Constant Current
1	1	0	Cell balancing starts when a cell needing balancing is greater than CBMIN and less than CBMAX. VEOC sets when the highest cell voltage is >VEOC threshold, and then cell balancing and DFET (if CPWR = 1) shut off. The charger changes from constant current to constant voltage. When the charge current drops below the IEOC limit (0x10, <a href="#">page 78</a> ) BATT FULL is set, CFET (and DFET if CPWR = 0) is shut off, and AUTO CB is cleared.	Constant Current followed by Constant Voltage
1	1	1	Cell balancing starts when a cell needing balancing is greater than CBMIN and less than CBMAX. CB continues after VEOC is reached and the bit is set, but DFET shuts off if CPWR=1. The charger changes from constant current to constant voltage. Cell balancing continues until the charge current drops below the IEOC limit; next, BATT FULL is set, CFET (and DFET if CPWR = 0) is shut off, and AUTO CB is cleared.	Constant Current followed by Constant Voltage
0	0	1	Cells charged until the VEOC threshold is exceeded and the VEOC bit sets, which shuts off CFET (and DFET if CPWR = 0). Cell balancing starts and continues until cell voltages fall below VEOC and stops, the BATT FULL bit is set, and AUTO CB is cleared.	Constant Current
0	1	1	Constant current charging until the VEOC threshold is exceeded and the VEOC bit sets, which shuts off DFET if CPWR = 1. The charger changes from constant current to constant voltage. Cell balancing occurs while one or more cell voltages are above the VEOC limit AND the charge current is above the IEOC limit. BATT FULL is set when the charge current drops below the IEOC limit. When BATT FULL is set, CFET is shut off (and DFET if CPWR = 0), and AUTO CB is cleared.	Constant Current followed by Constant Voltage

Registers [“0x26-27 CB Cell State” on page 75](#) show the cells automatically determined by the chip to need cell balancing following the most recent set of cell voltage measurements during scan before automatic cell balancing.

[Figure 109 on page 116](#) is an illustration of the Automatic Cell Balancing sequence described in detail in the following subsections. All settings must be written to the ISL94216 before [“0x01.0 System Trigger” on page 41](#) is executed. This example assumes the ISL94216 is in SCAN mode, the system is charging the battery pack and the step [“Cell Balance” on page 110](#) has been reached. The same sequence is followed if AUTO CB is enabled and cell balancing is started by the bit [“0x25.4 CB Trigger” on page 74](#).

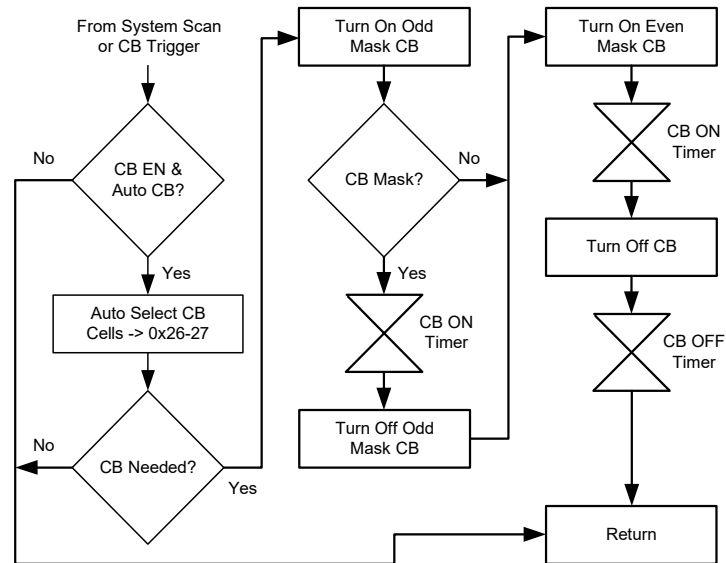

Figure 109. Auto CB Sequence

#### 7.4.1.1 Auto CB Sequence

**CB EN & Auto CB?** - If [“0x25.7 CB EN”](#) and [“0x25.6 Auto CB EN”](#) are both enabled the CB sequence moves to the next step, otherwise it exits and returns to the System Scan sequence step [“Scan Delay”](#).

**Auto Select CB Cells** - For the three cases of automatic cell balancing where IEOC EN = 1 **OR** CB EOC = 0, the chip finds the minimum of all the cell voltages and calculates the difference between each cell voltage and the minimum. For cells with a calculated difference higher than the [“0x2A CB Min Delta Threshold”](#), the CB Cell State bit is set to “1”. For other cells, it is set to “0”.

For automatic cell balancing cases with IEOC EN = 0 **AND** CB EOC = 1, the CB Cell State bit is set to “1” for cells that exceed the voltage set by the register [“0x2D VEOC Threshold”](#) minus four bits. For other cells, it is set to “0”.

**CB Needed?** - If no cells require cell balancing or the criteria determined by the settings of bits CB CHRG, IEOC EN, and CB EOC as detailed in [Table 76](#) are not met, the cell balance sequence exits and returns to step [“Scan Delay”](#). Otherwise the CB sequence moves to the next step.

Note: If AUTO CB EN = 0, the bit [“0x66.0 Need CB”](#) is an indicator to the user.

**Turn On Odd Mask CB** - Cell balance devices for the odd numbered cells that were automatically determined to require balancing as indicated by the CB Cell State registers 0x26-27 are turned on.

**CB Mask?** - If the bit [“0x25.2 CB Mask”](#) is clear (“0”), the sequence moves to the **Turn On Even Mask CB** step, otherwise the **CBON Timer** is activated per the following step.

**CBON Timer** - The timer setting [“0x28 CBON”](#) determines how long the cell balance FETs are enabled for each cycle of balancing. The sequence moves to the next step after the CBON Timer times out.

**Turn Off Odd Mask CB** - Cell balance FETs for the odd cells are turned off.

**Turn On Even Mask CB** - The cell balance FETs for the even numbered cells that were automatically determined to require balancing as indicated by the CB Cell State registers 0x26-27 are turned on.

**CBON Timer** - The timer setting [“0x28 CBON”](#) determines how long the cell balance FETs are enabled for each cycle of balancing. The sequence moves to the next step after the CBON Timer times out.

**Turn Off CB** - Cell Balance FETs for all cells are turned off.

**CBOFF Timer** - The timer setting [“0x29 CBOFF”](#) determines how long the cell balance FETs are disabled following each cycle of balancing. This step is necessary when long cell balancing times relative to the setting of

“0x2E.2:0 Scan Delay” are used. The CBOFF timer also manages power dissipation. The sequence moves to the next step after the CBOFF Timer times out.

**Return** - The CB state machine exits and returns to the Scan sequence at “Scan Delay” on page 111 after the CBOFF Timer times out.

### 7.4.2 Manual Cell Balancing

Manual Cell Balancing follows the sequence shown in “Manual CB Sequence”, which is very similar to that of Automatic Cell Balancing with a few important differences. Bit “0x25.7 CB EN” must be set to “1” to enable manual cell balancing, and bit “0x25.6 Auto CB EN” must be set to “0” to disable automatic cell balancing.

The master must determine the cells to be balanced and write the bits in registers “0x26-27 CB Cell State”. A “1” is written to cell locations selected for charge reduction and a “0” is written to cell locations that receive the full charge current.

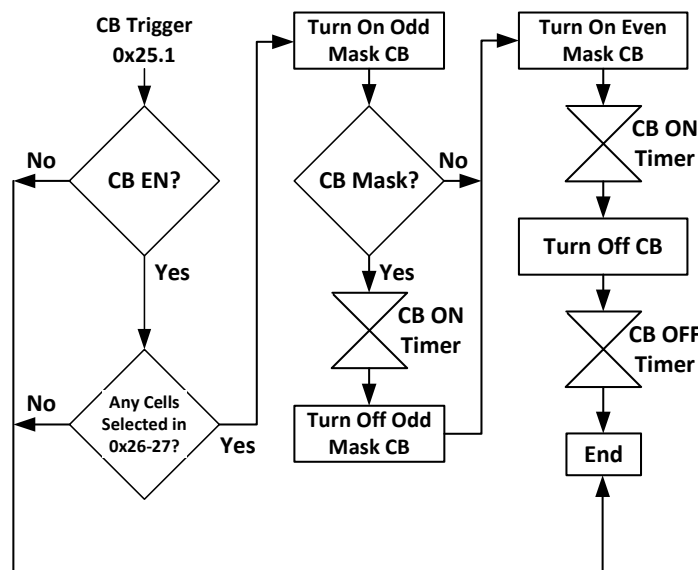

Figure 110. Manual CB Sequence

Bit “0x25.2 CB Mask” controls whether all cells that need balancing are turned on simultaneously or in separate ON cycles. Simultaneous cell balancing of too many and/or adjacent cells can be inefficient and raise the die temperature from the power dissipation of the internal cell balancing FETs if “0x25.5 CB Configuration” = 0.

All relevant settings must be written to the ISL94216 before cell balancing is triggered (“0x25.4 CB Trigger”).

#### 7.4.2.1 Manual CB Sequence

**CB Trigger** - With the ISL94216 in SCAN mode, (Scan Select must be set to 1 for single scan), the master must set the bits in registers “0x26-27 CB Cell State” to “1” for cells that have charged to relatively higher voltages than the rest of the pack. Bits for the other cells are set to “0” so they receive the full charge current. For manual cell balancing, the criteria used to determine which cells to get the reduced charge current is determined by the user.

When ready, the master triggers Cell Balancing by writing a “1” to “0x25.4 CB Trigger”.

**CB EN?** - If bit “0x25.7 CB EN” is not set to “1”, the CB sequence exits, otherwise it moves to the next step.

**Any Cells Selected in 0x26-27?** - The master must determine the cells to be balanced, and write the bits in registers “0x26-27 CB Cell State” before the CB Trigger. If no cell is selected the cell balance sequence exits.

**Note:** With Auto CB EN set to “0” for Manual Cell Balancing the NEED CB bit has no function.

**Turn On Odd Mask CB** - The cell balance FETs for the odd numbered cells that were manually determined to require balancing as indicated by the CB Cell State registers 0x26-27 are turned on.

**CB Mask** - If the bit "[0x25.2 CB Mask](#)" is clear ("0"), the CB sequence moves to the **Turn On Even Mask CB** step, otherwise the **CBON Timer** is activated per the next step.

**CBON Timer** - The Timer setting "[0x28 CBON](#)" determines how long the cell balance FETs are enabled for each cycle of balancing. The sequence moves to the next step after the CBON Timer times out.

**Turn Off Odd Mask CB** - Cell balance FETs for the odd cells are turned off.

**Turn On Even Mask CB** - The cell balance FETs for the even numbered cells that were manually determined to require balancing as indicated by the registers "[0x26-27 CB Cell State](#)" are turned on.

**CBON Timer** - The timer setting "[0x28 CBON](#)" determines how long the cell balance FETs are enabled for each cycle of balancing. The sequence moves to the next step after the CBON Timer times out.

**Turn Off CB** - Cell balance FETs for all cells are turned off.

**CBOFF Timer** - The timer setting "[0x29 CBOFF](#)" determines how long the cell balance FETs are disabled for each cycle of balancing. The sequence moves to the next step after the CBOFF Timer times out.

**End** - The CB state machine exits after the CBOFF Timer times out.

## 7.5 Charge Pump

The ISL94216 has an internal Charge Pump with an external capacitor used to drive the CFET, DFET, and CB16 pins. Control bit "[0x24.7 CPMP EN](#)" allows the user to enable or disable the Charge Pump as needed. The default value for the control bit is "0" so the Charge Pump is disabled following a chip power up or reset. If the charge pump is enabled ( $0x24.7 = "1"$ ), the status bit "[0x65.5 CPMP NRDY](#)" is set by the ISL94216 to "1" until the charge pump voltage is up to its operating level, then it clears to "0". If the charge pump is disabled by the Master setting  $0x24.7 = "0"$ , then bit CPMP NRDY is also set to "0".

Charge Pump circuitry is automatically disabled in SHIP and LOW POWER Modes regardless of the setting of bit  $0x24.7$  CPMP EN.

The charge Pump State Machine is detailed below in [Figure 111](#).

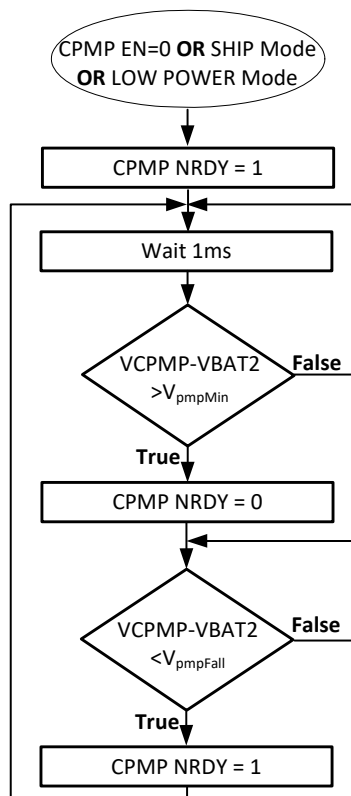

Figure 111. ISL94216 Charge Pump Ready State Machine

### 7.5.1 Charge Pump Ready State Machine

The state machine starts at the point at which the charge pump is disabled during the power up sequence (see [Figure 111](#)) or at chip reset, by being in SHIP or LOW POWER mode, or by bit 0x24.7 CPMP EN being “0”. Bits “0x24.7 CPMP EN” on [page 70](#) and “0x65.5 CPMP NRDY” on [page 83](#) are set to “0” following POR or reset.

The state machine starts when the charge pump is enabled ( $0x24.7 = 1$ ), in IDLE or SCAN Modes. The device begins charging the external capacitor at an operational frequency of ~4MHz. Once the charge pump voltage is above the minimum threshold  $V_{pmpMin}$  ([page 16](#)) the state machine clears bit CPMP NRDY. Next, the charge pump voltage is continuously compared to the  $V_{pmpFall}$  ([page 16](#)) threshold. If the voltage drops below that threshold, the state machine sets bit CPMP NRDY.

The charge pump enable bit is set to “0” by default at POR or Reset, or by the master. Transitions to SHIP or LOW POWER mode automatically shut off the charge pump. The mode change shuts off the charge pump regardless of whether it was executed by the master or caused by a fault detection. If the charge pump was enabled, the not ready bit is also set when the charge pump voltage drops below the internal fixed threshold.

The charge pump enable bit is not affected by a mode change, it is only changed by the master directly. After the enable of the charge pump a minimum 1ms wait occurs to allow time for the circuitry to begin charging the external capacitor.

### 7.6 Trigger Bits

Some control registers have bits called “Trigger bits” that execute automatic sequences when set to “1”. Triggered sequences are initiated by a 0 to 1 transition of a Trigger bit. When the triggered sequence starts, the Trigger bit is reset back to 0 automatically by the chip. A 0 to 1 transition of a Trigger bit is ignored if that triggered sequence is already in progress. If a Trigger bit is ignored, the chip does not clear the Trigger bit automatically. In this case, to start a triggered sequence, the user must first write a 0 followed by a 1 to the Trigger bit.

The System Trigger bit (“0x01.0 System Trigger” on [page 41](#)) is ignored when the System mode bits are SHIP, LOW POWER, or IDLE. It is executed only when the bits “0x2E.7:6 System Mode” on [page 101](#) are set to SCAN mode. All other Trigger bits are ignored in SHIP or LOW POWER Modes, and can only trigger sequences in IDLE or SCAN mode. These Trigger bits should be used only in IDLE mode because Renesas recommends to reserve SCAN mode for System Scans only.

If the ISL94216 is running a sequence started by a previous Trigger bit transition, then the new Trigger bit transition is queued. It is scheduled for when the sequence in progress completes.

If the ISL94216 is in a condition that prevents running the desired sequence, the Trigger bit transition is ignored. It is not executed when the condition changes. For example, if the chip has a fault that prevents executing the Trigger bit, then the fault goes away, and a new 0 to 1 transition of the Trigger bit is needed to start the sequence. This applies unless the chip is in the middle of a sequence started by a previous Trigger bit transition, in which case the triggered sequence executes.

When multiple Trigger bits are in the queue, only the one with highest priority is executed. When its execution starts, all other queued Trigger bits are cleared. This means that besides the triggered sequence in progress, only one more is executed later because the queue is cleared when the second starts. When the second starts, the user can queue a third one that is executed when the second completes. The priority is fixed in design, from high to low: “0x01.0 System Trigger” on [page 41](#), “0x01.5 Recalibrate  $V_{OS}$  Trigger” on [page 40](#), “0x02.0  $V_{CELL}$  Trigger” on [page 43](#), “0x03.0  $I_{PACK}$  Trigger” on [page 44](#), “0x11.0 ETAUX Trigger” on [page 57](#), “0x1B.0  $V_{REG}$  Trigger” on [page 64](#), “0x1F.5 ITEMP Trigger” on [page 67](#), “0x1F.0 VBAT1 Trigger” on [page 67](#), “0x24.5 OW Trigger” on [page 71](#), and “0x25.4 CB Trigger” on [page 74](#).

When the previous triggered sequence is completed, the circuit first takes the Trigger bit in queue with highest priority, and clears the entire queue. Next, it checks the conditions against the Trigger bit to be executed. If conditions do not allow it to be executed, the circuit goes back to IDLE mode, otherwise the circuit starts the new sequence. A Fault never clears the queue.



## 8. Communication Interface

The ISL94216 includes a digital interface for the user to configure operation as well as monitor input and output parameters. Serial communication interfaces are available anytime the chip is not being reset. The ISL94216 supports I<sup>2</sup>C, SPI, and Single Wire serial interfaces. The protocol is chosen by connecting the CMS0 and CMS1 pins. The CMS pins are static inputs and must not change state while the ISL94216 is powered. Never set both of these pins high simultaneously. If this occurs, set them to a valid state and RESET the ISL94216. The hardware configuration required to support each communication protocol is listed in [Table 77](#).

The ISL94216 supports sequential read, which can start at any register address. If the master continues to send clock cycles or a presence bit is sent after reading one byte, the device indexes to the next byte and returns the byte value. This continues until the load bit or stop bit is received or CS returns high.

The ISL94216 supports sequential read back commands for all three protocols.

**Table 77. Serial Protocol Defined**

CMS1	CMS0	Protocol
DGND	DGND	I <sup>2</sup> C
DGND	VDD	SPI
VDD	DGND	Single Wire
VDD	VDD	Reserved - Invalid State!

A comparison of the approximate read times for the three protocols is shown in [Table 78](#).

**Table 78. Approximate Read Times**

Communication Sequence	Number of Bytes to Read Back	Transaction Time (ms)		
		I <sup>2</sup> C (100kHz)	SPI (2MHz)	Single Wire
Read All (0x00-0x89)	138	14.11	0.69	18.17
Read V <sub>CELL</sub> (0x30-0x51)	34	3.36	0.166	4.517
Read I <sub>PACK</sub> (0x52-0x57)	6	0.84	0.041	1.493
Read OTHER (0x58-0x62)	11	1.29	0.062	2.033
Read FAULT (0x63-0x69)	7	0.93	0.045	1.601

### 8.1 I<sup>2</sup>C Serial Interface

This device supports a bidirectional bus oriented protocol. The protocol defines any device that sends data onto the bus as a transmitter and the receiving device as the receiver. The device controlling the transfer is the master and the device being controlled is the slave. The master always initiates data transfers and provides the clock for both transmit and receive operations. Therefore, the ISL94216 operates as the slave device in all applications. All communication over the I<sup>2</sup>C interface is conducted by sending the MSB of each byte of data first.

#### 8.1.1 I<sup>2</sup>C Address

The ISL94216 can be used with any I<sup>2</sup>C host device. Each device must have its own unique serial address to distinguish it from other devices on the bus. The device address is set by connecting the ADDR/ $\overline{\text{CS}}$  pin to either VDD or DGND. The available addresses are listed in [Table 79](#).

**Table 79. I<sup>2</sup>C Address Values**

Logic Selections	Address (7-bit Binary)
ADDR/ $\overline{\text{CS}}$ pin tied to VDD	0011 010
ADDR/ $\overline{\text{CS}}$ pin tied to DGND	0001 010



### 8.1.2 Protocol Conventions

Data states on the SDA line can change only during SCL LOW periods. The SDA state changes during SCL HIGH are reserved for indicating START and STOP conditions (see [Figure 112](#)). At power-up, the SDA pin is in the input mode.

All I<sup>2</sup>C interface operations must begin with a START condition, which is a HIGH to LOW transition of SDA while SCL is HIGH. The device continuously monitors the SDA and SCL lines for the START condition and does not respond to any command until this condition is met (see [Figure 112](#)). A START condition is ignored during the power-up sequence.

All I<sup>2</sup>C interface operations must be terminated by a STOP condition, which is a LOW to HIGH transition of SDA while SCL is HIGH (see [Figure 112](#)). A STOP condition at the end of a Read operation, or at the end of a Write operation returns the I<sup>2</sup>C state machine to its initial state where it waits for the next START.

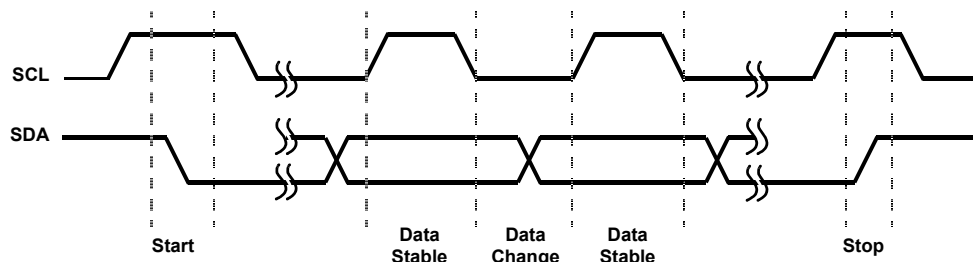

Figure 112. Valid Data Changes, Start, and Stop Conditions

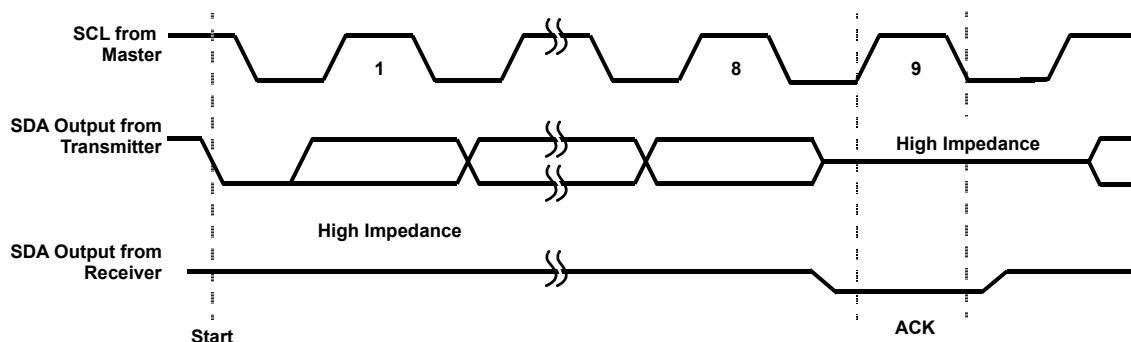

Figure 113. Acknowledge Response from Receiver

An Acknowledge (ACK) is a software convention that indicates a successful data transfer. The transmitting device, either master or slave, releases the SDA bus after transmitting eight bits. During the ninth clock cycle, the receiver pulls the SDA line LOW to acknowledge the reception of the eight bits of data (see [Figure 113](#)). The device responds with an ACK after recognition of a START condition followed by a valid Slave Address byte, and once again after successful receipt of the Register Address Byte. The device also responds with an ACK after receiving each Data Byte of a Write operation. The master must respond with an ACK after receiving each Data Byte of a Read operation except the last one.

The last bit of the Slave Address byte defines a read or write operation to be performed. When this  $\overline{R/\overline{W}}$  bit is a "1", a Read operation is selected. A "0" selects a Write operation (see [Figure 114](#)).

After loading the entire Slave Address byte from the SDA bus, the device compares it with the internal Slave Address. With a correct compare, the device outputs an acknowledge on the SDA line.

### 8.1.3 Write Operation

A Write operation requires a START condition, followed by a Slave Address byte, a Register Address byte, a Data byte, and a STOP condition (see [Figure 114](#)). The slave device responds with an ACK after successfully receiving each of the three bytes. The content of the Data byte is transferred to the ISL94216 registers at the rising edge of SCL during the ACK that follows the reception of the Data byte.

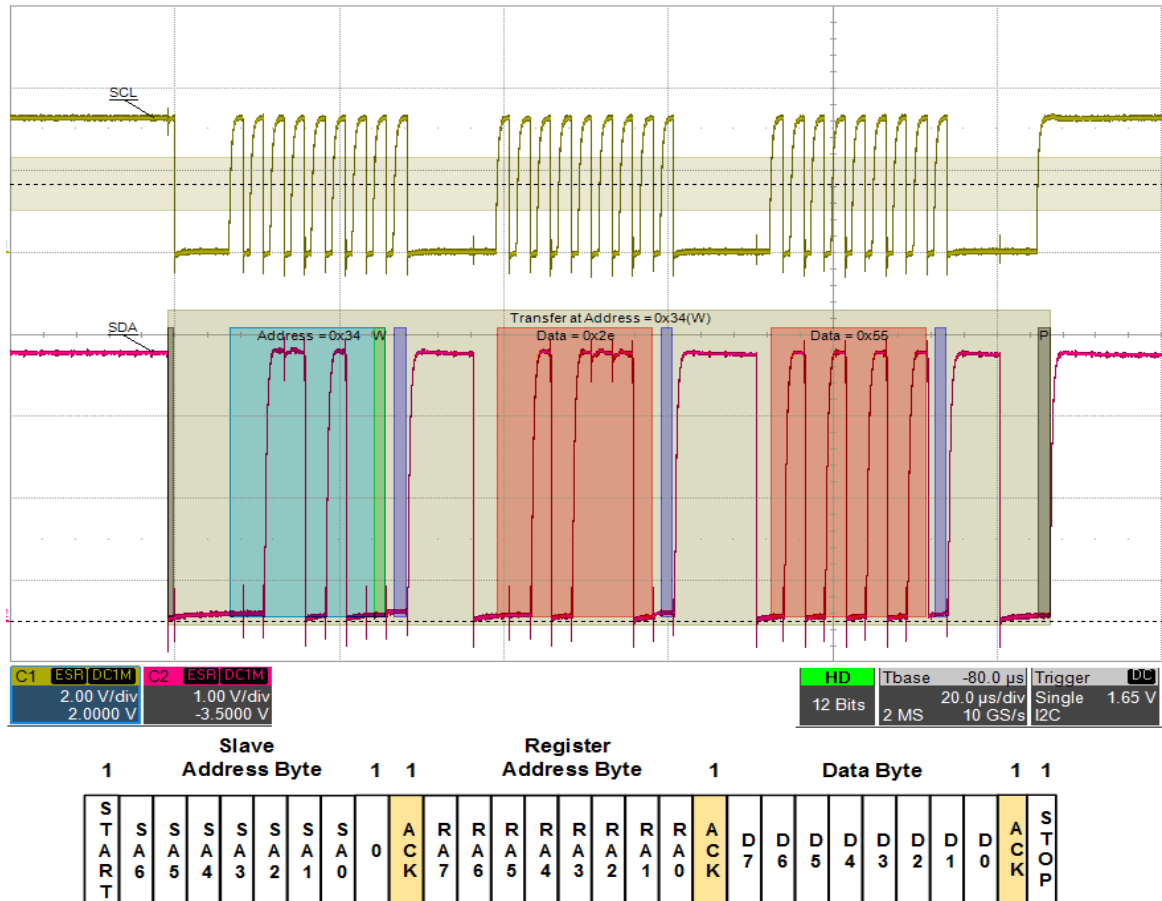

I2C 1-BYTE WRITE  
 Figure 114. I2C Write Protocol

### 8.1.4 Read Operation

A Read operation consists of a three byte sequence, followed by one or more Data bytes (see [Figure 115](#)). The master initiates the operation issuing the following sequence: a START, the Slave Address byte with the R/W bit set to “0”, a Register Address byte, a second START, and a second Slave Address byte with the same seven MSBs but with the R/W bit set to “1”. After each of the three bytes, the ISL94216 responds with an ACK. The ISL94216 transmits Data bytes as long as the master responds with an ACK during the SCL cycle following the eighth bit of the first byte. The master terminates the Read operation by issuing a NACK followed by a STOP condition.

The Data bytes are from the memory location indicated by an internal pointer. This pointer’s initial value is determined by the address byte in the Read operation instruction, and increments by one during transmission of each Data byte.

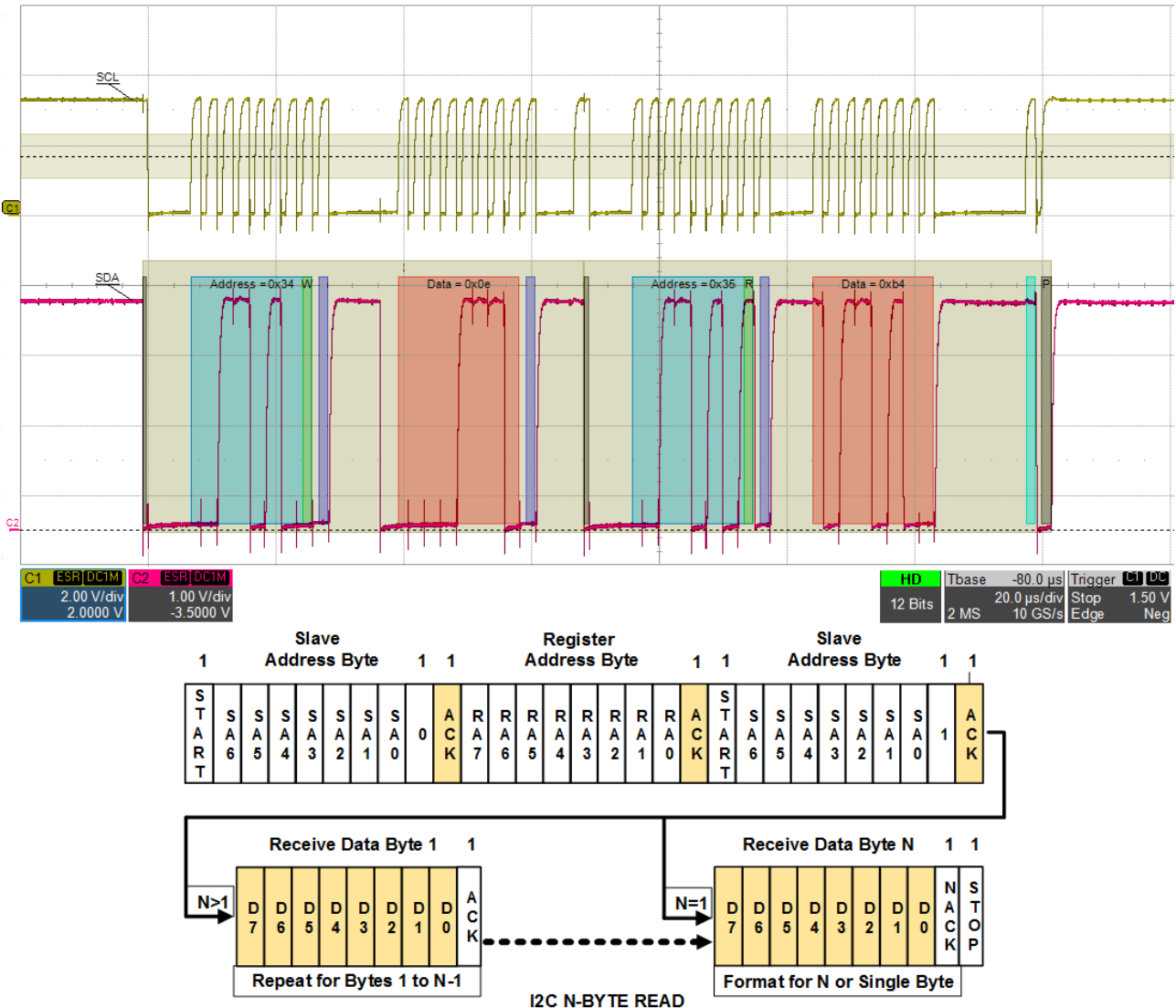

Figure 115. I<sup>2</sup>C Read Protocol

### 8.1.5 I<sup>2</sup>C Timing

I<sup>2</sup>C timing is illustrated in Figure 116, see specification table for specific values.

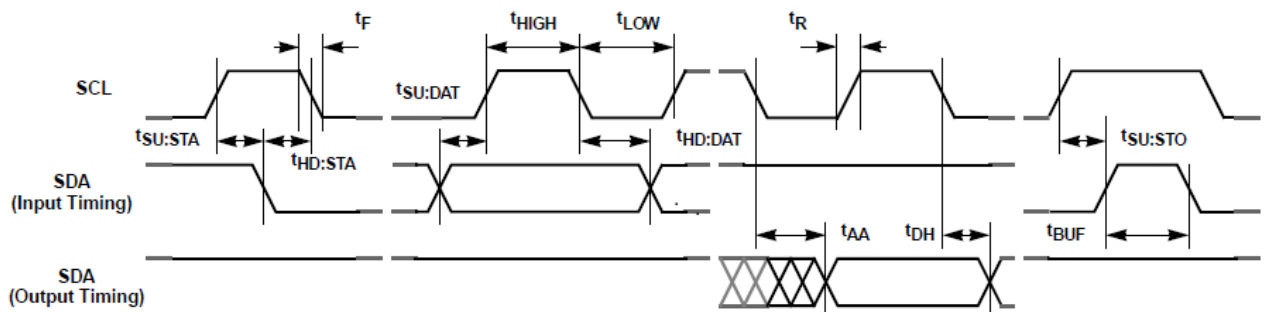

Figure 116. I<sup>2</sup>C Timing

## 8.2 SPI Serial Interface

The ISL94216 supports the SPI communication protocol. SPI has become a standard that does not have an officially released specification generated by any international committee. This gives some flexibility in implementing the SPI protocol but also requires programmable flexibility of the master microcontroller. This

protocol defines any device that sends data onto the bus as a transmitter, and the receiving device as the receiver. The device controlling the transfer is called the master and the device being controlled is called the slave. The master always initiates data transfers, and provides the clock for both transmit and receive operations. The ISL94216 operates as a slave in all applications and all communication over the interface is conducted by sending the Most Significant Bit (MSB) of each byte first.

The ISL94216 is accessed through the MOSI (Master Output Slave Input) and SCL (Serial Clock) pins, and the output data is presented by the ISL94216 at the MISO (Master Input Slave Output) pin. Input data at pin MOSI is clocked in on the rising edge of SCL when CS is LOW. Output data at pin MISO is clocked out on the falling edge of SCL.

All commands start with a falling edge at the input pin  $\overline{CS}$  and include the Identification, Register Address, and Data Bytes. Write operations end with a rising edge at the input pin  $\overline{CS}$  after the last bit of the Data bytes being written is clocked in. Read operations end with a rising edge at the input pin  $\overline{CS}$  after the last bit of the Data byte being read is clocked out.

Controlling the ISL94216 with a SPI interface is similar to I<sup>2</sup>C in that the formats are comparable with the small differences. SPI requires the use of four data lines (SCL, MOSI, MISO, and  $\overline{CS}$ ) for successful communication between master and slave. Unlike I<sup>2</sup>C, SPI does not use ACK or NACK, START is replaced by the falling edge of  $\overline{CS}$ , and STOP is replaced by the rising edge of  $\overline{CS}$ .

The ISL94216 SPI interface has a maximum clock frequency of SPI\_f<sub>SCL</sub> (2Mhz, [page 18](#)). A time delay of SPI\_t<sub>WAIT</sub> (7μs, [page 19](#)) is required between bytes.

## 8.2.1 Identification Byte

The Identification byte is the first byte sent by the Master. It is a combination of the ISL94216 SPI Slave address and the Read/Write bit. The slave address is shifted left one bit while the R/W bit is the Least Significant Bit (LSB) of the Identification Byte ([Figure 117 on page 125](#)).

### 8.2.1.1 CRC Disabled

To operate with CRC disabled the Slave Address of the ISL94216 is 0x0A and the R/W bit is set to “1” for a Read or to “0” for a Write. When these are combined, the Identification byte is 0x15 for a Read ([Figure 119 on page 126](#)) and 0x14 for a Write ([Figure 117 on page 125](#)).

### 8.2.1.2 CRC Enabled

To operate with CRC enabled the Slave Address of the ISL94216 is 0x4E and the R/W bit is set to “1” for a Read or to “0” for a Write. When these are combined, the Identification byte is 0x9D for a Read and 0x9C for a Write ([Figure 118 on page 125](#)) with CRC enabled.

## 8.2.2 Write Operation

Write Operation with CRC disabled is selected by setting the Read/Write bit in the Identification byte to “0” while using the slave address of 0x0A. On a write command with CRC disabled, the device transfers the Data byte to the register on the falling edge of the 24th (SCL) clock cycle. [Figure 117](#) illustrates a single byte SPI Write sequence with CRC disabled.

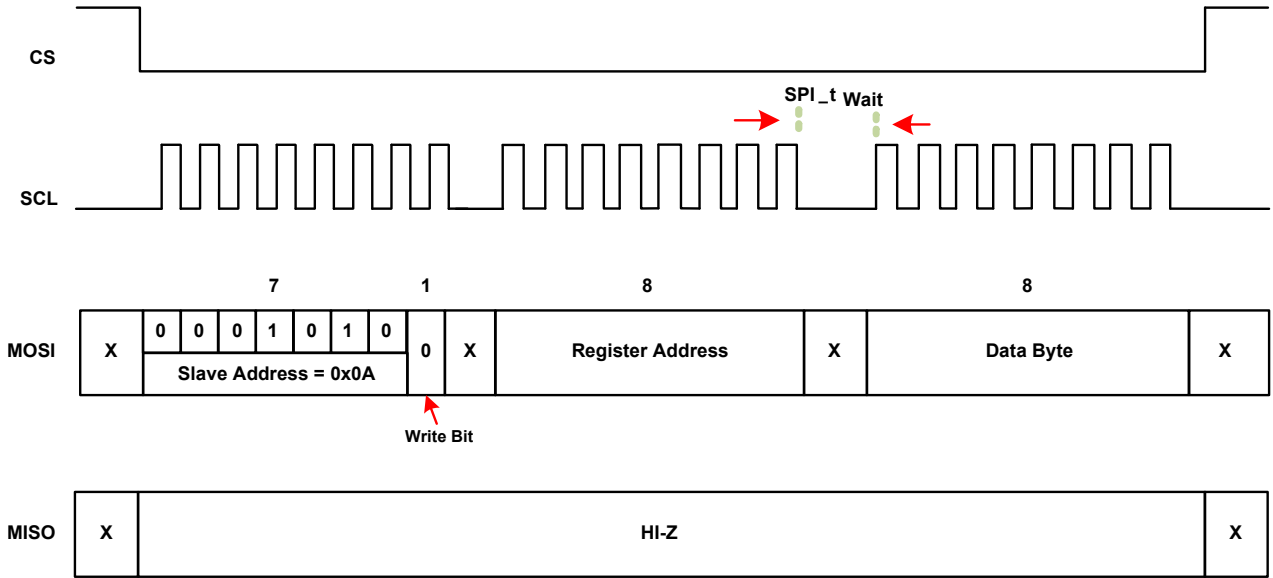

Figure 117. SPI Write

A single byte write operation with CRC enabled uses the slave address of 0x4E and requires two extra bytes for the 16-bit CRC word. Figure 118 is an example of a single byte write with CRC enabled. The CRC word is calculated by the Master from the Identification, Register Address and Data bytes. The MSB of the CRC word is transmitted first and the least significant byte follows it. See section “CRC Calculation” on page 127 for details of CRC calculation.

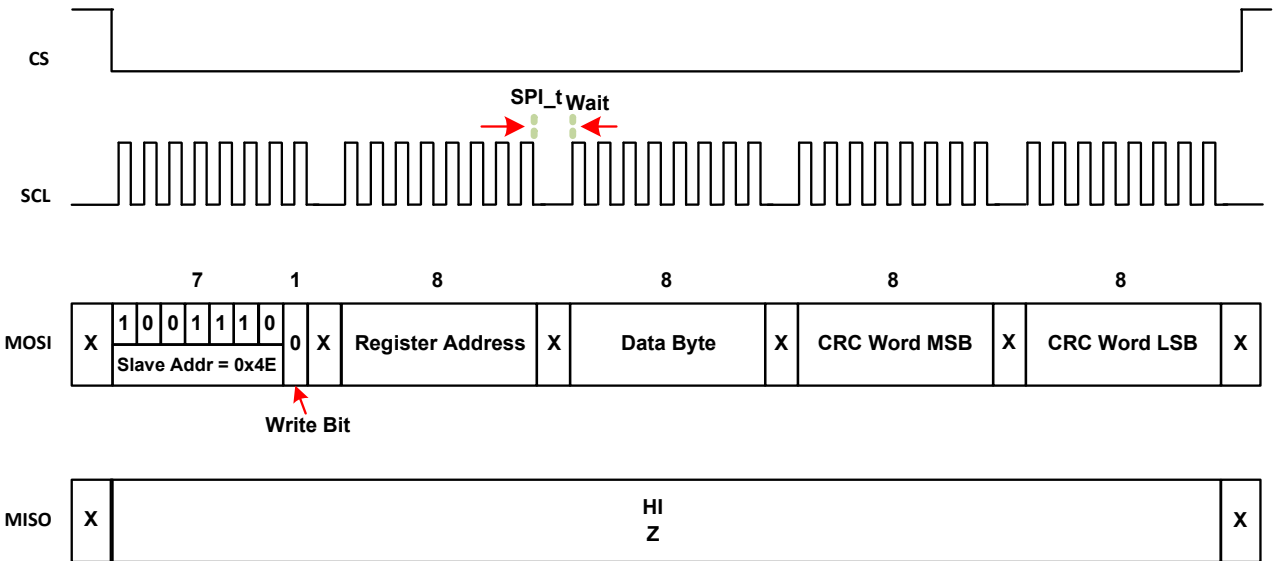

Figure 118. SPI Write w/CRC

### 8.2.3 Read Operation

Read Operation with CRC disabled is selected by setting the Read/Write bit in the Identification Byte to “1” while using the slave address of 0x0A. Figure 119 illustrates the SPI Read sequence with CRC disabled. The ISL94216 supports sequential read with CRC disabled by automatically incrementing the register address pointer to the next location.

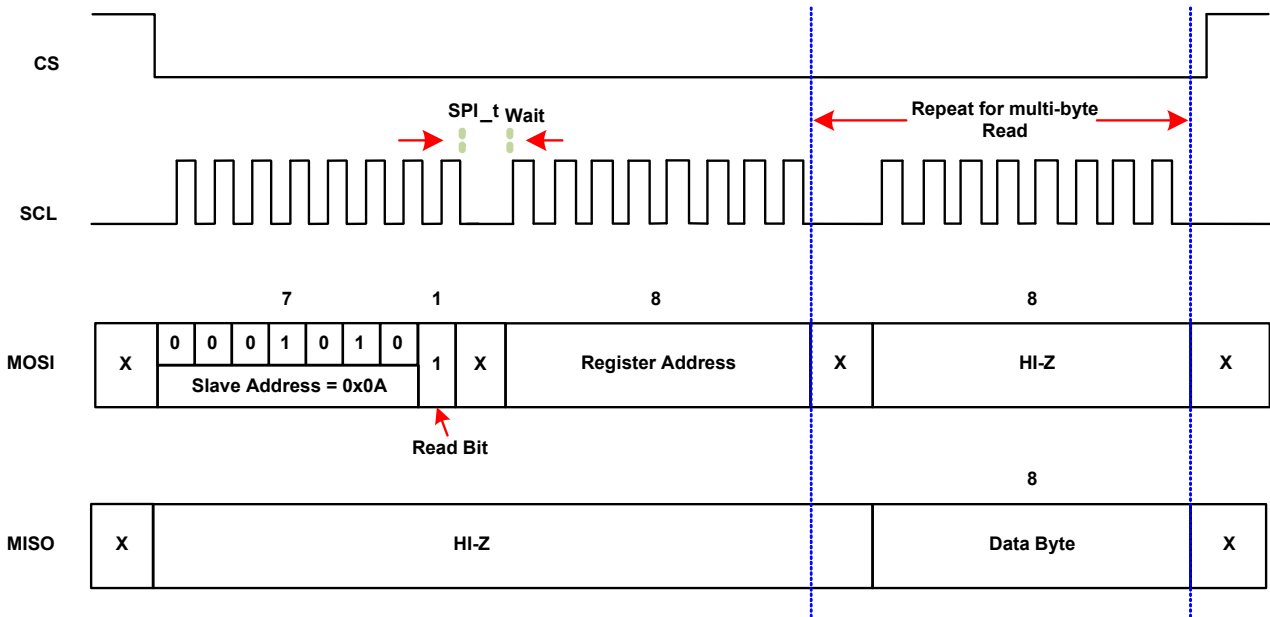

Figure 119. SPI Read

A read operation with CRC enabled uses the slave address of 0x4E and requires four bytes from the Master consisting of the Slave address with write bit (“[Identification Byte](#)” on page 124), an 8bit address or command code byte and 2 bytes for the 16bit CRC word. The read command CRC word is calculated by the Master from the Identification and Register Address (or command) bytes. If a register address is used, then Slave responds with one byte of register data and 2 bytes for the response 16bit CRC word (calculated by the Slave).

The sequential read of multiple bytes with CRC enabled is supported by command codes used in place of the register address in the second byte sent by the Master. The supported command codes are listed in [Table 80](#).

Table 80. CRC Read Command Codes

Read Registers	Command Code	Starting Address	Ending address	Byte Count
All Registers	0x9A	0x00	0x89	138
Measurement	0x9B	0x30	0x62	51
V <sub>CELL</sub>	0x9C	0x30	0x51	34
I <sub>PACK</sub>	0x9D	0x52	0x57	6
Other	0x9E	0x58	0x62	11
Faults	0x9F	0x63	0x69	7

[Figure 120 on page 127](#) is an example of a READ I<sub>PACK</sub> command with CRC enabled. Again, the Master calculates and transmits the first CRC word based in the Identification and Command bytes while the Slave calculates and transmits the response CRC word based on the data it sends. If the Slave determines the read command CRC is incorrect it sets fault bit “[0x65.0 CRCF](#)” and holds MISO high for the entire read back sequence until CS returns high signaling the end of the sequence. A CRC of all 1’s is an indication of a communications fault.

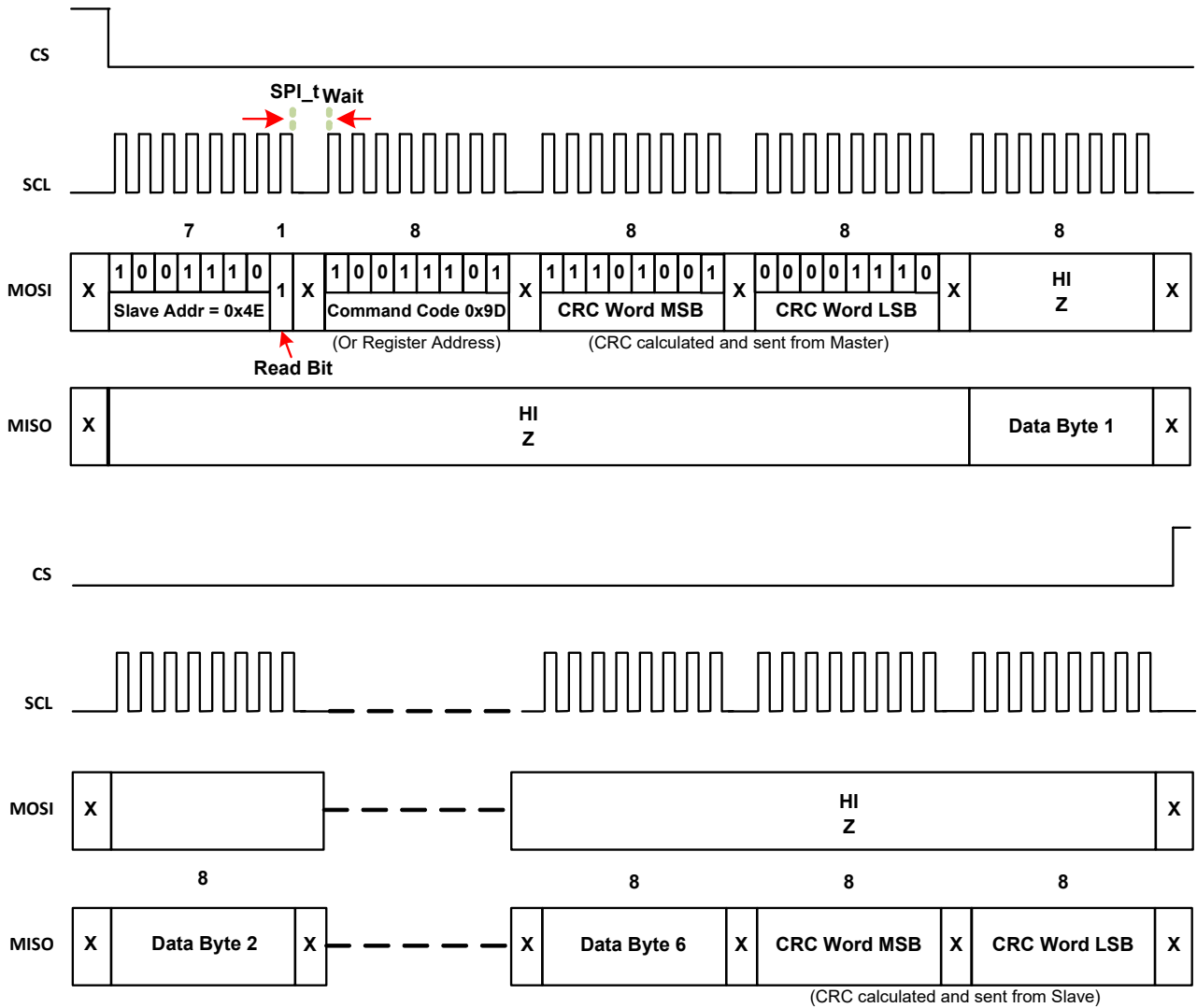

See section [“CRC Calculation” on page 127](#), [“Example CRC VBA Code” on page 129](#) and [“Example CRC C-Code” on page 131](#) for details on CRC calculation.

Figure 120. SPI IPACK Read w/CRC

### 8.2.4 CRC Calculation

The ISL94216 CRC implementation is compliant with the CRC-CITT16 X25 protocol. See [“Example CRC VBA Code” on page 129](#), [“Example CRC C-Code” on page 131](#) and [Figure 121](#) for calculation steps.

SPI Writes with CRC enabled include a 2-byte CRC word ([Figure 118 on page 125](#)) calculated by the Master from the values of the first 3-bytes of the 5-byte sequence. SPI Reads are in the format of [Figure 120 on page 127](#) where the first CRC Word is calculated by the Master from the values of the first 2-bytes of the 4-byte MOSI sequence while the CRC Word at the end read sequence is calculated by the ISL94216 Slave based on the data it sent on MISO. In all three of these cases, it is the responsibility of the receiver to calculate the CRC value of the received bytes to compare with the received CRC and then act accordingly.

If the comparison for an SPI Write fails, the ISL94216 asserts fault bit [“0x65.0 CRCF” on page 84](#) and ignores the Write.

If the comparison for an SPI Read fails, the ISL94216 asserts fault bit [“0x65.0 CRCF”](#) and ignores the read. The ISL94216 holds MISO high until the Master releases CS. A CRC value of all 1’s indicates a failure. If the Master determines the CRC comparison fails following the data read, then it must determine the appropriate reaction.

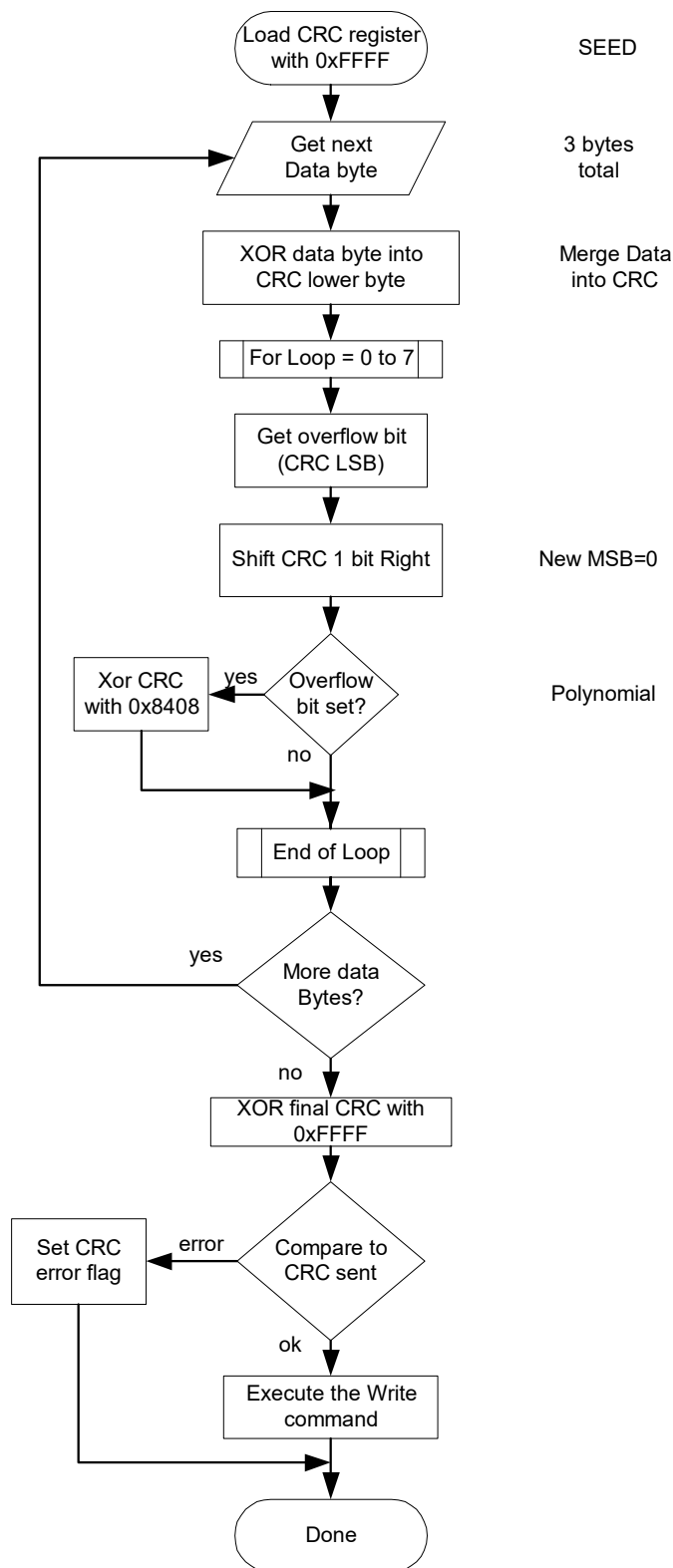

Figure 121. CRC Calculation Flowchart



### 8.2.4.1 Example CRC VBA Code

Example VBA code that calculates the CRC16-CITT-X25 checksum value (CRC word):

```
*****
Option Explicit
Public Function crcCheckValX25(ByVal buf As String) As Long
*****
' Equation is X16+X12+X5+1 or &H1021 (ignore X16)
' The X25 standard uses the CRC-CITT standard with the following conditions;
'   The starting CRC value is 0xFFFF.
'   The input bit stream is reflected.
'   The output CRC is reflected.
'   The final action is to XOR the value with 0xFFFF.
' Note: Reflecting the input data bits and the crc output bits is equivalent
'   to reflecting the poly (0x1021 --> 0x8408) and shifting the CRC bits right as opposed to left.
*****

Dim NumBytes As Integer
Dim DataStr As String
Dim Databyte As Long
Dim Bite As Byte
Dim crc As Long

If (Len(buf) Mod 2) <> 0 Then buf = "0" & buf      ' if excel drops leading zero
If Len(buf) < 1 Then buf = "00"                  ' if no data
NumBytes = Len(buf) \ 2
crc = 65535                                       'Initializes the CRC to the seed
Debug.Print "CCITT_X25 input " & buf & " num bytes " & Str(NumBytes)
For Bite = 0 To NumBytes - 1                       ' for each byte
    DataStr = Mid(buf, 2 * Bite + 1, 2)           'read next byte
    Databyte = CInt("&H" & DataStr)              'convert byte string to integer
    crc = (crc Xor Databyte) And 65535            ' XOR the data into lower 8 bits of crc
    Debug.Print " byte data " & Hex$(Databyte)
    Debug.Print " byte crc " & Hex$(crc)
    crc = CRC16_X25(crc, &H8408)                 ' shift the bits and XOR with polynomial
    crc = crc And 65535                          ' this keeps the CRC value in 16bit format.
Next Bite
crc = (Not crc) And 65535                         ' XORing with 0xFFFF is the same as a bit invert
crcCheckValX25 = crc

End Function

Private Function CRC16_X25(ByVal crc As Long, polyVal As Long) As Long
*****
' Updates the CRC for each bit in the byte - reflected format
*****
```

```
Dim i As Byte, XorFlag As Boolean, bit As Byte
CRC16_X25 = crc
For bit = 0 To 7                                ' shift/XOR each bit in the byte
    XorFlag = False
    If (crc And &H1&) = 1 Then XorFlag = True    'LSB=1, need to xor with poly
    crc = (crc \ 2) And 65535                    ' shift right 1 bit
    Debug.Print "  shift " & Hex$(crc) & " " & Str$(XorFlag)
    If XorFlag Then crc = (crc Xor polyVal) And 65535 ' xor crc with poly
    Debug.Print "  bit crc " & Hex$(crc)
Next bit
CRC16_X25 = crc
```

**End Function**

### 8.2.4.2 Example CRC C-Code

Example C code that calculates the CRC16-CITT-X25 checksum value (CRC word):

```

/*Calculates the CRC checksum for an array of bytes for ISL94216 Rev 0 03/21/19 Renesas Corp*/
#include <stdio.h>

void main()                                // code to run the crc and print results
{
    int i;
    unsigned long int CRCval;                // final checksum
    unsigned char INPUT_DATA[100];          // input array (uchar=1byte)
    int NumBytes;                            // number of bytes to use
    NumBytes=3;
    INPUT_DATA[0] = 0x84;                    // fill in the input data
    INPUT_DATA[1] = 0xD0;
    INPUT_DATA[2] = 0x01;
    printf(" ---- ISL94216 CRC calculator ---- \n");
    printf("Number of Bytes = %d \n", NumBytes);
    printf("Input Data (hex) = ");
    for(i=0; i<NumBytes; i++) printf("%02x ", INPUT_DATA[i]);
    printf("\n");
    CRCval = Calc_CRC_94216(NumBytes, INPUT_DATA); // find the CRC checksum
    printf("CRC16 final (hex) = %04x \n", CRCval);
} //main

unsigned long int Calc_CRC_94216(int NumBytes, unsigned char *data)
{
    // Call with input data array & NumBytes set, returns the final crc
    // This code reflects the polynomial and shifts right instead of reflecting the data & CRC (easier to code)
    //

|                   |              |               |
|-------------------|--------------|---------------|
|                   | standard X25 | ISL94216 code |
| // CRC_POLY       | 0x1201       | 0x8408        |
| // CRC_SEED       | 0xFFFF       | 0xFFFF        |
| // CRC_XOR        | 0xFFFF       | 0xFFFF        |
| // REFLECT_INPUT  | TRUE         | FALSE         |
| // REFLECT_OUTPUT | TRUE         | FALSE         |
| // Byte XOR       | MSB          | LSB           |
| // Bit Shift      | Left         | Right         |

    //
    int i, j, XorFlag;
    unsigned long int CRCval;
    CRCval=0xFFFF; // starting point = SEED
    for(i=0; i<NumBytes; i++)
    {
        CRCval = CRCval ^ long(data[i]); // XOR data with CRC
    }
}

```

```

for(j=0; j<8; j++) // shift for each bit & check for XOR
{
  XorFlag=0;
  if(CRCval & 1)XorFlag=1; // LSB = Xor Flag
  CRCval=CRCval>>1; // shift right 1 bit
  if(XorFlag>0) CRCval=CRCval ^ 0x8408; // XOR with poly
} //for j
} //for i
CRCval=CRCval ^ 0xFFFF; // xor the final crc
return(CRCval);
} //Calc_

```

### 8.2.5 SPI Timing

SPI timing is illustrated in [Figure 122](#) and [Figure 123](#), see specification table for specific values. Symbol names listed in the specification tables include leading characters “SPI\_” which are omitted from the following figures for clarity.

Symbol  $t_{CS}$  is not specified because it is a function of the command sequence. Even though the device logic will recognize short  $t_{CS}$  pulse widths it cannot be expected to respond immediately with correct results if the preceding command has not completed execution. For example, a System Trigger command must be allowed to complete its task before attempting to read the results from a measurement register.

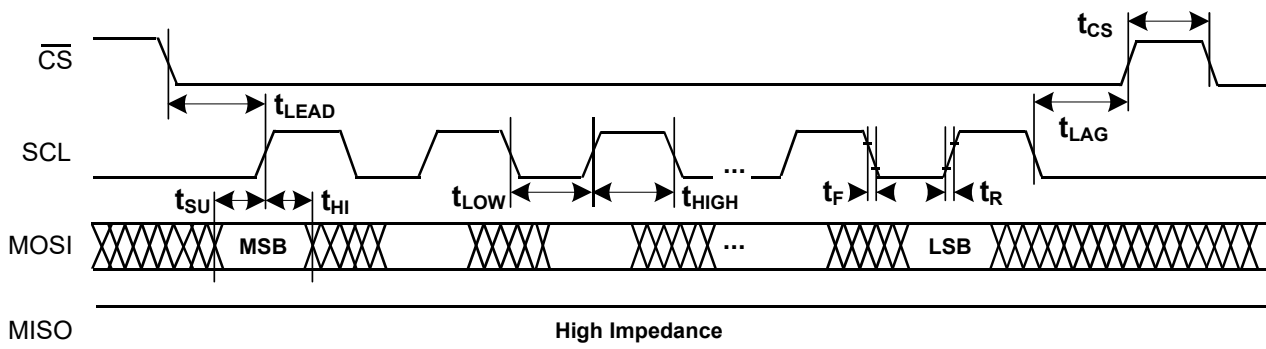

Figure 122. SPI Input Timing

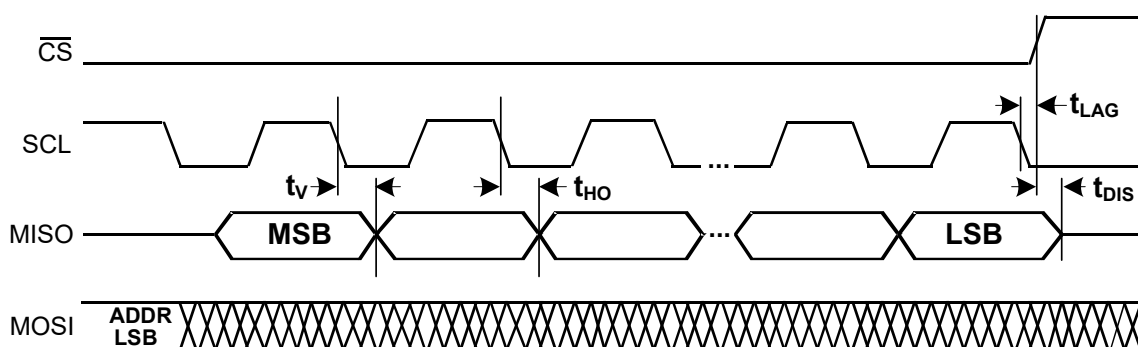

Figure 123. SPI Output Timing

### 8.3 Single Wire Interface

The ISL94216 can be controlled through a Single Wire interface if the CMS0/1 pins are configured as described in [Table 77 on page 120](#) to use this communication format. Single Wire is a single line serial communication protocol that uses a time based method for the master to communicate with the slave.

The list of symbols used by the Single Wire interface is defined to be equivalent to the list of I<sup>2</sup>C symbols, and the sequences of symbols used by the Single Wire interface are set up to match the I<sup>2</sup>C sequences. The available sequences are: “Write a byte” and “Read one or more bytes”.

The Single Wire Interface differs from I<sup>2</sup>C by the addition of time outs. The Single Wire protocol state machine goes to its initial state if no transition is detected at the Single Wire interface for a long time. This is equivalent to detecting a STOP symbol in an I<sup>2</sup>C communication, or the Load symbol in this Single Wire protocol. Specifications for detecting a long time with no transitions are different when the wire is LOW versus when the wire is HIGH. They are called Time Out Low or  $t_{TOLSW}$  (300us, [page 21](#)) and Time Out High or  $t_{TOHSW}$  (35ms, [page 21](#)).

The Single Wire input path in the ISL94216 has a glitch suppression filter. Any pulse narrower than the min  $t_{glitch}$  (50ns, [page 21](#)) specification is ignored by the ISL94216. This filter is the standard 400 kHz I<sup>2</sup>C filter.

Single Wire drivers are Open Drain. When the Single Wire interface is idle (no symbols are being transmitted), the logic level at the Single Wire pin is HIGH.

All symbols are active low pulses of various widths. The symbol names are listed in the Electrical Specifications on [page 20](#).

Whether doing a read or write transaction, a not present symbol sent by the slave to the master is required before a load symbol is sent. In a Read operation, the not present symbol informs the master that there are no more bytes to read. In a Write operation, the not present symbol transfers the byte contents to the register of the device.

All symbols begin with a falling edge driven by the master.

Reset, Load, Write 0, Write 1, Read 1, and Not Present symbols are fully driven by the master.

Present symbols can be fully driven by the master, or can be initiated by the master and completed by the slave, depending on the location in the communication sequence.

All Read 0 symbols and some Present symbols are initially driven by the master, and driven by both the master and the slave, and finally driven only by the slave. The slave determines the location of the rising edge that completes those symbols.

Write 0, Read 0, and Present symbols are distinguished by their location in sequences of symbols, because they have the same pulse width specifications.

Write 1, Read 1, and Not Present symbols are distinguished by their location in sequences of symbols, because they have the same pulse width specifications.

When reading a symbol from the ISL94216, the master drives the wire with a pulse that has the pulse-width of a narrow valid pulse: a “1” or “0” symbol (see the Electrical Specifications on [page 20](#)).

If the symbol that is supposed to be read is a “1” or a “Not Present”, then ISL94216 does not drive the Single Wire pin. It just waits for the next falling edge, or for a “time out” determined with on-chip timers.

If the symbol that is supposed to be read is a “0” or a “Present”, soon after detecting a falling edge the ISL94216 drives the Single Wire pin to extend the total pulse-width.

#### 8.3.1 Single Wire Address

The ISL94216 can be used with any Single Wire host device. More than one slave device can be used with a single Single Wire master device. Each device must have its own unique serial address to distinguish it from other devices on the bus. The device address is set by connecting the ADDR/ $\overline{CS}$  pin to either VDD or DGND. The available addresses are listed in [Table 81](#).

**Table 81. Single Wire Address Values**

Logic Selections	ISL94216 Address (7 MSBs)
ADDR/ $\overline{CS}$ pin tied to VDD	0011 010
ADDR/ $\overline{CS}$ pin tied to DGND	0001 010

### 8.3.2 Single Wire Read/Write Sequences

The data sequence for Single Wire read and write is the same as that for I<sup>2</sup>C read and write transactions. The Single Wire read and write sequences are shown in [Figures 124](#) through [Figure 126](#).

The write sequence follows these steps:

- Reset (Start) → Slave Address Byte with R/ $\overline{W}$  bit = 0 → Present →
- Register Address Byte → Present → Data Byte from Master → Present → Load (Stop)

The sequence to read 1 to N Bytes is:

- Reset (Start) → Slave Address Byte with R/ $\overline{W}$  bit = 0 → Present →
- Register Address Byte → Present → Reset (Start) → Slave Address Byte with R/ $\overline{W}$  bit = 1 →
- Present → Data Byte from Slave {Repeat this line N times for N bytes of data}
- Load (Stop)

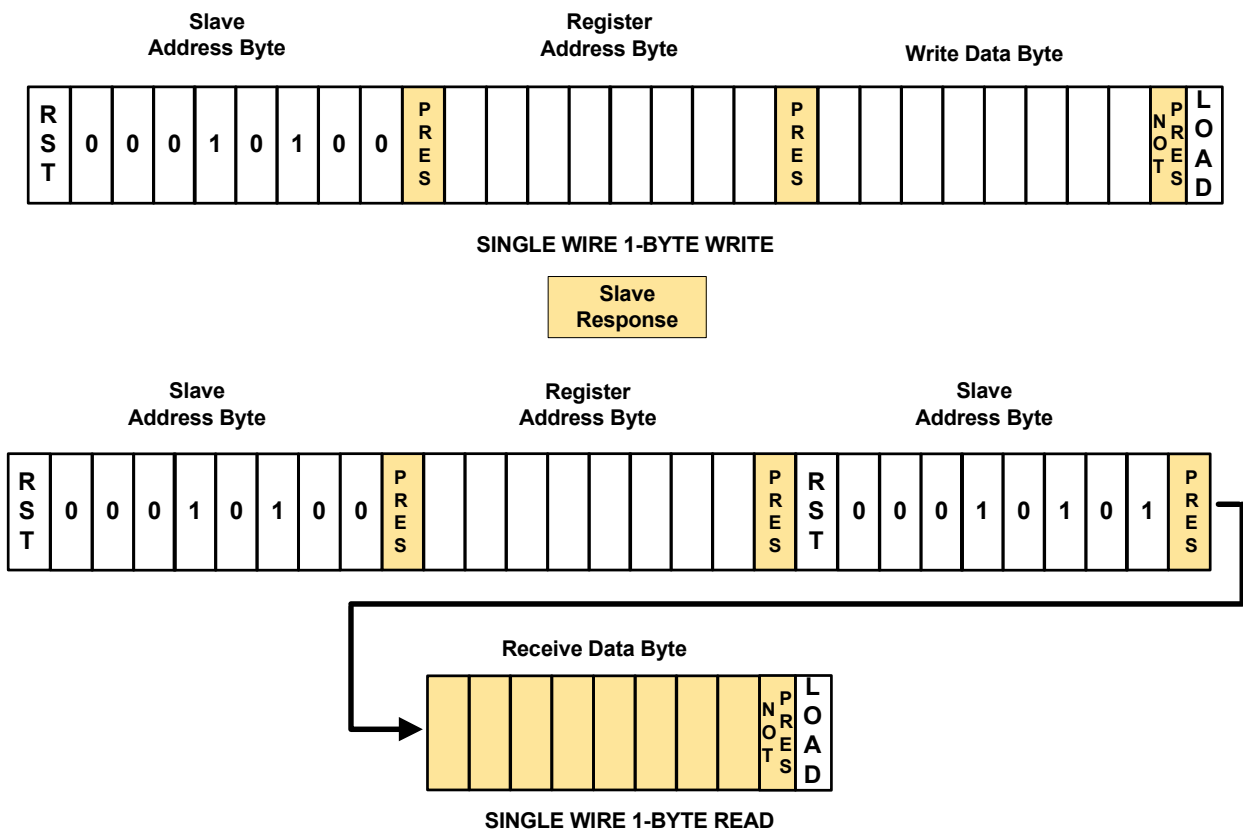

**Figure 124. Single Wire Read/Write Protocol**

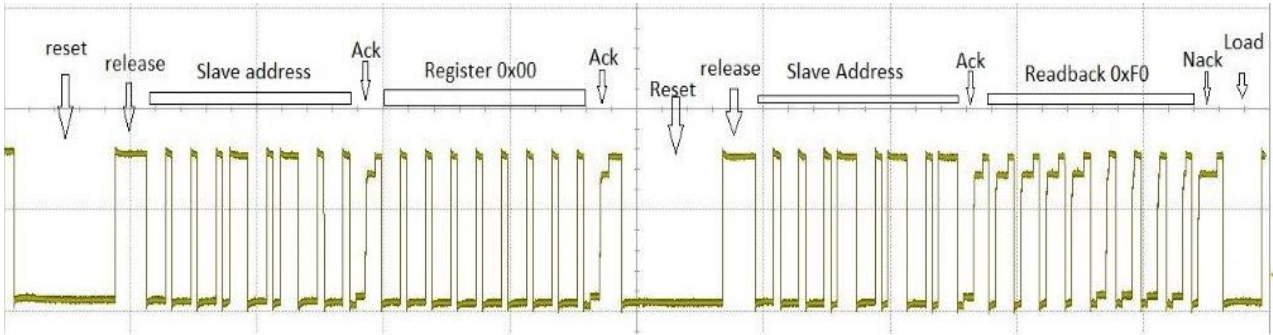

Figure 125. Single Wire Read Example

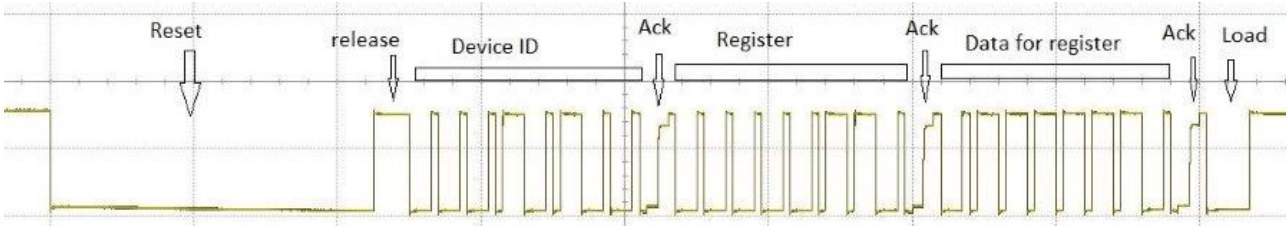

Figure 126. Single Wire Write Example

### 8.3.3 Single Wire Timing

Figures 128 and 129 illustrate the of Single Wire symbols. The relationships between the transmitter pulse widths and receiver thresholds are shown in Figure 127.

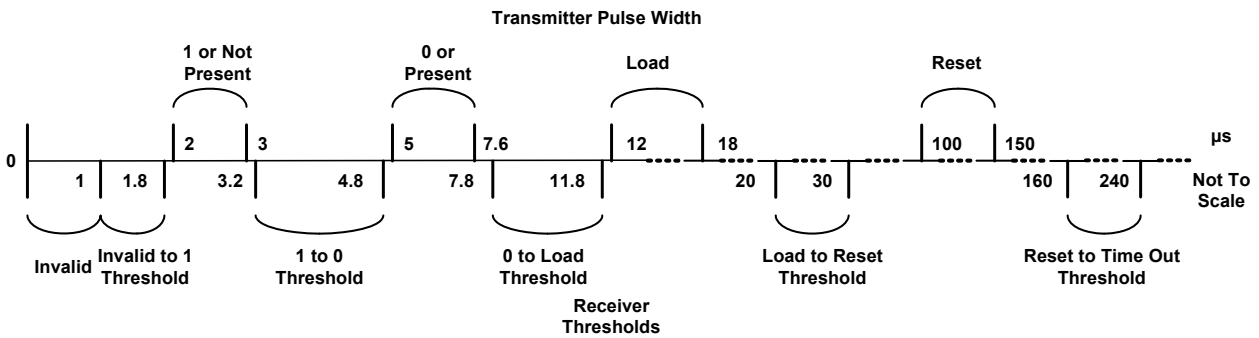

Figure 127. Single Wire Symbol Timing

The definition of pulse-width and bit periods for symbols driven by the master are detailed in Figure 128.

To identify symbols, the receiver may sample the Single Wire during the windows indicated in the graph as “Receiver Thresholds”, or alternatively, it may use a timer to measure falling edge to rising edge pulse-widths at the Single Wire.

The Receiver Thresholds can also be referred to as Receiver Sample Windows.

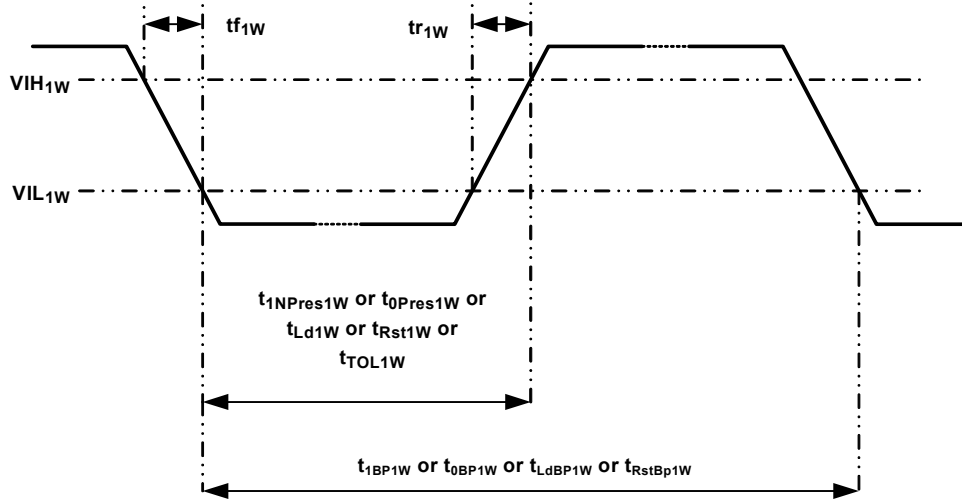

Figure 128. Timing of Symbols Driven by Master

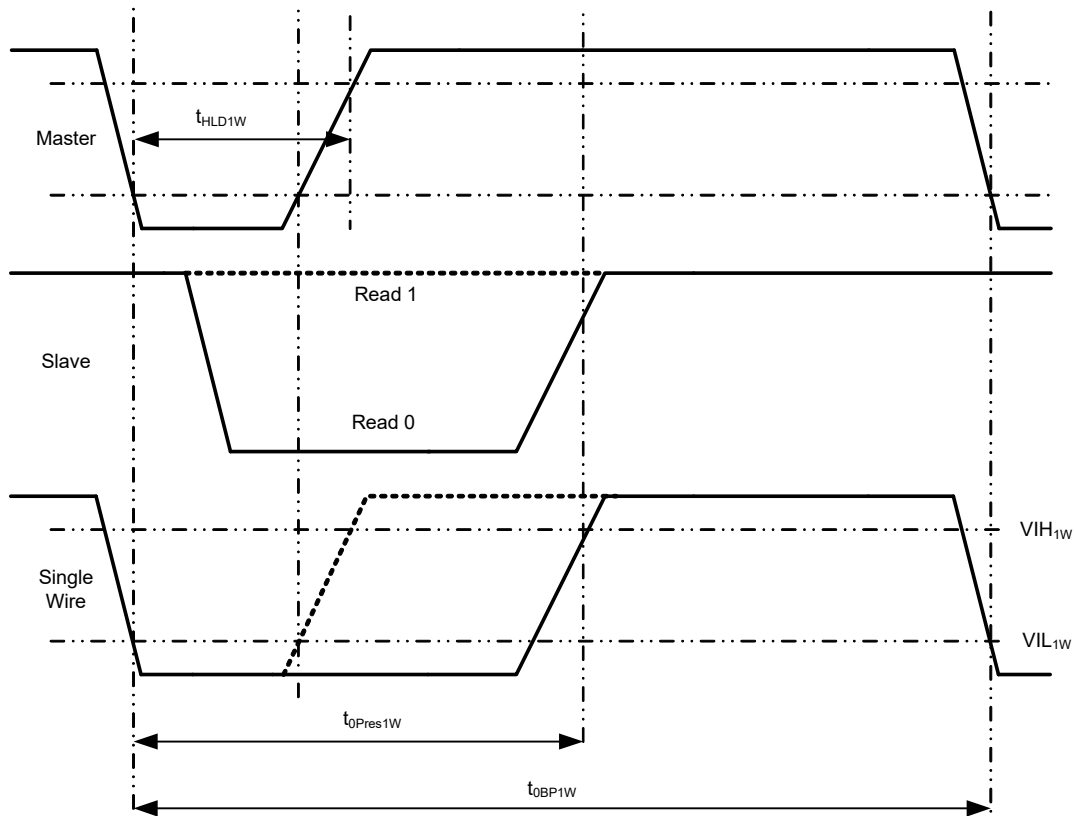

Figure 129. Master/Slave Symbol Timing

The timing of symbols partially driven by the master and partially driven by the slave are shown in [Figure 129](#). The top waveform is the output of the master, the center waveform is the output of the slave, and the bottom waveform is the result that appears on the Single Wire line. In cases in which no slave response occurs, it remains high impedance.

The master or the slave output is high impedance when not being driven Low.

The symbol position within the communication sequence relative to a preceding R/W bit is used to differentiate between symbols that otherwise share timing specifications. That is, between a “1” and “Not Present”, and between a “0” and “Present”.



## 9. Reduced Cell Count

The ISL94216 is designed to monitor between 4 and 16 cells. When using less than 16 cells, it is important that each used cell has a normal input circuit connection to the top and bottom monitoring inputs for that cell. The simplest way to use the ISL94216 with any number of cells is to always use the full input circuit arrangement for all VCn inputs, and short together the unused inputs at the battery terminal. In this way, each cell input sees a normal source impedance regardless of whether it is monitoring a cell.

The cell balancing components associated with unconnected cell inputs are not required and can be removed. Unused cell balance outputs should be tied to the cell voltage monitoring pin below it. For example, tie CB9 to VC8 in a 15-cell application.

The input circuit component count can be reduced in cases in which fewer than 14 cells are being monitored. It is important that cell inputs that are being used are not connected to other unused cell inputs, as this affects measurement accuracy.

See [Figure 130](#) and the following table for connections with cell counts less than 16.

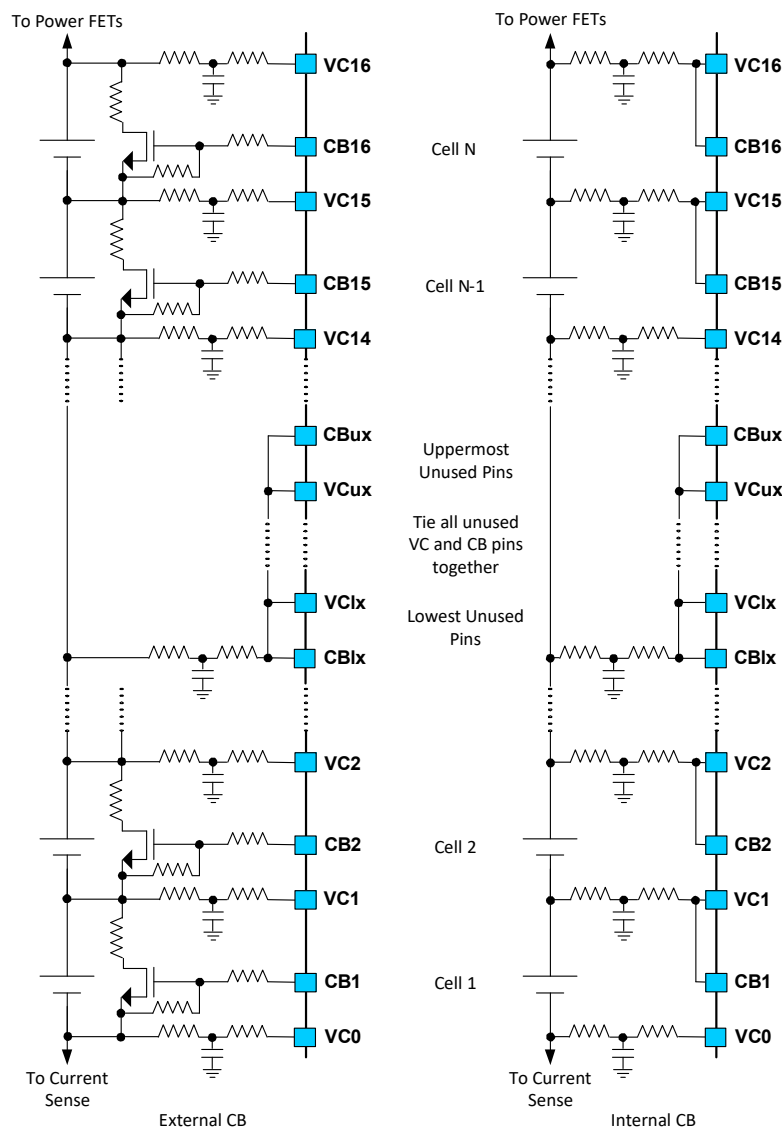

Figure 130. 4 to 14 Cell Count Example

Pin	Pos/Neg Cell Connection Versus Cell Count												
VC16	16	15	14	13	12	11	10	9	8	7	6	5	4
CB16													
VC15	15/16	14/15	13/14	12/13	11/12	10/11	9/10	8/9	7/8	6/7	5/6	4/5	3/4
CB15													
VC14	14/15	13/14	12/13	11/12	10/11	9/10	8/9	7/8	6/7	5/6	4/5	3/4	2/3
CB14												3/4	2/3
VC13	13/14	12/13	11/12	10/11	9/10	8/9	7/8	6/7	5/6	4/5	3/4	3/4	2/3
CB13										4/5	3/4	3/4	2/3
VC12	12/13	11/12	10/11	9/10	8/9	7/8	6/7	5/6	4/5	4/5	3/4	3/4	2/3
CB12								5/6	4/5	4/5	3/4	3/4	2/3
VC11	11/12	10/11	9/10	8/9	7/8	6/7	5/6	5/6	4/5	4/5	3/4	3/4	2/3
CB11						6/7	5/6	5/6	4/5	4/5	3/4	3/4	2/3
VC10	10/11	9/10	8/9	7/8	6/7	6/7	5/6	5/6	4/5	4/5	3/4	3/4	2/3
CB10				7/8	6/7	6/7	5/6	5/6	4/5	4/5	3/4	3/4	2/3
VC9	9/10	8/9	7/8	7/8	6/7	6/7	5/6	5/6	4/5	4/5	3/4	3/4	2/3
CB9		8/9	7/8	7/8	6/7	6/7	5/6	5/6	4/5	4/5	3/4	3/4	2/3
VC8	8/9	8/9	7/8	7/8	6/7	6/7	5/6	5/6	4/5	4/5	3/4	3/4	2/3
CB8			7/8	7/8	6/7	6/7	5/6	5/6	4/5	4/5	3/4	3/4	2/3
VC7	7/8	7/8	7/8	7/8	6/7	6/7	5/6	5/6	4/5	4/5	3/4	3/4	2/3
CB7					6/7	6/7	5/6	5/6	4/5	4/5	3/4	3/4	2/3
VC6	6/7	6/7	6/7	6/7	6/7	6/7	5/6	5/6	4/5	4/5	3/4	3/4	2/3
CB6							5/6	5/6	4/5	4/5	3/4	3/4	2/3
VC5	5/6	5/6	5/6	5/6	5/6	5/6	5/6	5/6	4/5	4/5	3/4	3/4	2/3
CB5									4/5	4/5	3/4	3/4	2/3
VC4	4/5	4/5	4/5	4/5	4/5	4/5	4/5	4/5	4/5	4/5	3/4	3/4	2/3
CB4											3/4	3/4	2/3
VC3	3/4	3/4	3/4	3/4	3/4	3/4	3/4	3/4	3/4	3/4	3/4	3/4	2/3
CB3													2/3
VC2	2/3	2/3	2/3	2/3	2/3	2/3	2/3	2/3	2/3	2/3	2/3	2/3	2/3
CB2													
VC1	1/2	1/2	1/2	1/2	1/2	1/2	1/2	1/2	1/2	1/2	1/2	1/2	1/2
CB1													
VC0	1/CSP	1/CSP	1/CSP	1/CSP	1/CSP	1/CSP	1/CSP	1/CSP	1/CSP	1/CSP	1/CSP	1/CSP	1/CSP
Note	Tie these pins together then connect to cells through a single shared "T" network.												

Figure 131. Cell Count Matrix

## 10. Revision History

Rev.	Date	Description
3.03	Jun 15, 2023	Updated the typical value for the Internal Temperature Sensor Resolution spec from 0.8 to 0.85 and added the test condition. Updated cross-reference links throughout the document. Updated Tables 33, 40, 41, 56, 57, and 63.
3.02	May 18, 2023	Updated cross-reference link in the 0x63.7 VCCF section.
3.01	Feb 3, 2022	Updated Ordering Information table formatting. Updated the default value in Table 54. Updated the Manual Cell Balancing section.
3.00	Sep 1, 2021	Page 12, change "Discharge Short-Circuit Hysteresis" typical value from 20mV to 40mV. Page 35, row 0A, <ul style="list-style-type: none"> <li>Changed -20.083mV to -40.167mV</li> <li>Changed -321.33mV to -642.67mV</li> <li>Changed -40.167mV to -80.3mV</li> </ul> Page 47, Table 17, <ul style="list-style-type: none"> <li>Changed both instances of -20.083mV to -40.167mV</li> <li>Changed -40.167mV to -80.33mV</li> <li>Second sentence after table, change from "-40.167mV to -321.33mV" to "-80.33mV to -642mV"</li> </ul> Page 48, <ul style="list-style-type: none"> <li>Deleted the second and third sentence in the first paragraph after Table 19</li> <li>Deleted "For non-zero delay settings," from the beginning of the second paragraph then combined these two paragraph remnants.</li> </ul> Page 77 section 4.13.8.2 <ul style="list-style-type: none"> <li>Deleted "in IDLE mode following a manual CB or"</li> </ul> Page 110 <ul style="list-style-type: none"> <li>Replaced "CELLCON AND {DVCF OR (NOT[DCHRWUV] AND UVF) OR (NOT[CHRWUV] AND OVFF)}" with "CELLCON AND {DVCF OR (NOT[CHRWUV] AND UVF) OR NOT[DCHRWUV] AND OVFF}"</li> </ul> Page 115 near end of section 6.4.2 <ul style="list-style-type: none"> <li>Replaced "master should put the ISL94216 in IDLE mode by setting bits "0x2E.7:6 System Mode" to "00" with "master should put the ISL94216 in SCAN mode by setting bits 0x2E.7:6 System Mode to 01"</li> </ul> Page 115 section 6.4.2.1 <ul style="list-style-type: none"> <li>Replaced "With the ISL94216 in IDLE mode," with "With the ISL94216 in SCAN mode (Scan Select must be set to 1 for single scan),"</li> </ul>
2.00	Mar 4, 2021	Page 10, added VCPMP to the VBAT1, VBAT2 line. Page 11, changed the LDMON maximum value from 55V to VBAT2. Page 12, changed "Discharge Short-Circuit Hysteresis" typical value from "40" mV to "20" mV. Page 35, row 0A, <ul style="list-style-type: none"> <li>changed 40.167mV to -20.083mV</li> <li>changed -642.67mV to -321.33mV</li> <li>changed -80.3mV to -40.167mV</li> </ul> Page 47, Table 17, <ul style="list-style-type: none"> <li>Changed both -40.17mV to -20.083mV</li> <li>Changed -80.33mV to -40.167mV</li> <li>Second sentence after table, change from "-80.33mV to -642mV" to "-40.167mV to -321.33mV (Typ)"</li> </ul> Page 48, updated 0x0C DSC Delay section by adding paragraphs below Table 19. Page 56, second to last paragraph, last sentence, change "0x1B" to "0x3E" Page 90, first paragraph: <ul style="list-style-type: none"> <li>Replaced "limited to" with "approximately"</li> <li>Deleted "(0x0A DSC Threshold)"</li> <li>Replace "short-circuit and about -350mV ("0x0B DOC Threshold") for a discharge overcurrent" with "current".</li> <li>Deleted "(0x0F COC Threshold") for a charge overcurrent"</li> <li>Added the following sentence to the end of the paragraph "See "0x0A DSC Threshold", "0x0B DOC Threshold", and "0x0F COC Threshold" for current threshold settings."</li> </ul> Page 97 and 98 corrected typo changed cap value from 0.1uF to 1.0uF.
1.00	Jun 17, 2020	Initial release

# 11. Package Outline Drawing

For the most recent package outline drawing, see [L64.9x9B](#).

L64.9x9B  
 64 Lead Quad Flat No-Lead Plastic Package  
 Rev 1, 5/17

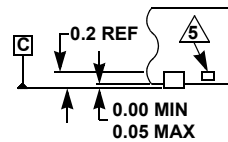
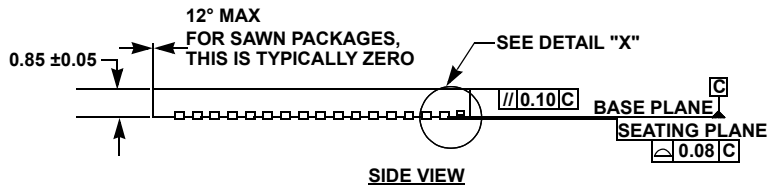
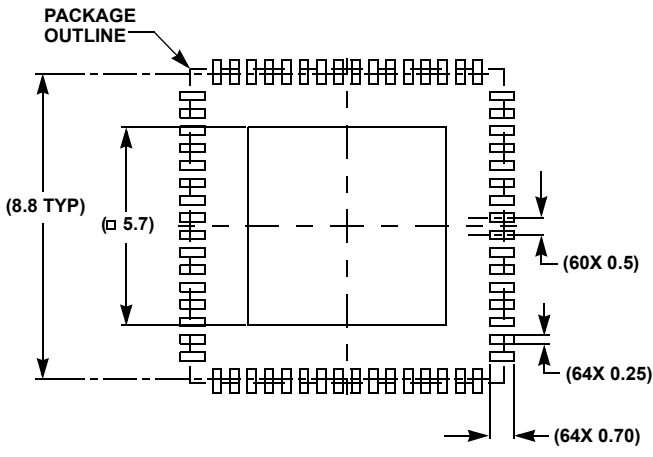
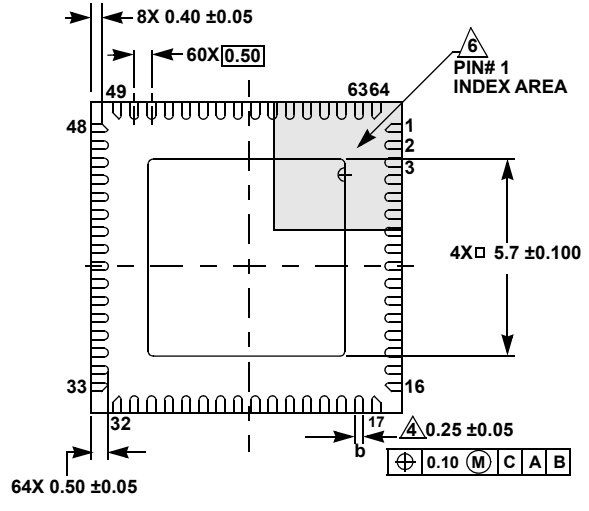
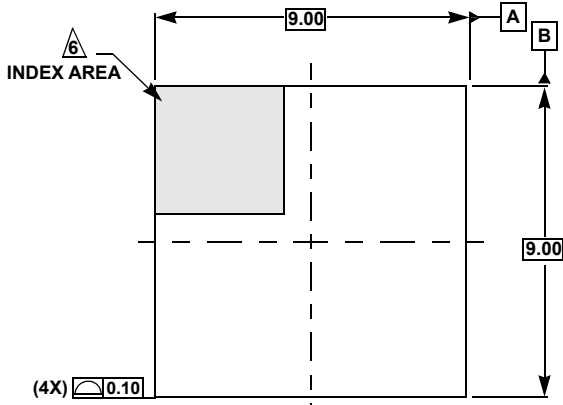

**NOTES:**

1. Dimensions are in millimeters.  
 Dimensions in ( ) for Reference Only.
2. Dimensioning and tolerancing conform to ASME Y14.5m-1994.
3. Unless otherwise specified, tolerance: Decimal ±0.05
4. Dimension b applies to the metallized terminal and is measured between 0.20mm and 0.30mm from the terminal tip.
5. Tiebar shown (if present) is a non-functional feature.
6. The configuration of the pin #1 identifier is optional, but must be located within the zone indicated. The pin #1 identifier may be either a mold or mark feature.

## IMPORTANT NOTICE AND DISCLAIMER

RENESAS ELECTRONICS CORPORATION AND ITS SUBSIDIARIES (“RENESAS”) PROVIDES TECHNICAL SPECIFICATIONS AND RELIABILITY DATA (INCLUDING DATASHEETS), DESIGN RESOURCES (INCLUDING REFERENCE DESIGNS), APPLICATION OR OTHER DESIGN ADVICE, WEB TOOLS, SAFETY INFORMATION, AND OTHER RESOURCES “AS IS” AND WITH ALL FAULTS, AND DISCLAIMS ALL WARRANTIES, EXPRESS OR IMPLIED, INCLUDING, WITHOUT LIMITATION, ANY IMPLIED WARRANTIES OF MERCHANTABILITY, FITNESS FOR A PARTICULAR PURPOSE, OR NON-INFRINGEMENT OF THIRD PARTY INTELLECTUAL PROPERTY RIGHTS.

These resources are intended for developers skilled in the art designing with Renesas products. You are solely responsible for (1) selecting the appropriate products for your application, (2) designing, validating, and testing your application, and (3) ensuring your application meets applicable standards, and any other safety, security, or other requirements. These resources are subject to change without notice. Renesas grants you permission to use these resources only for development of an application that uses Renesas products. Other reproduction or use of these resources is strictly prohibited. No license is granted to any other Renesas intellectual property or to any third party intellectual property. Renesas disclaims responsibility for, and you will fully indemnify Renesas and its representatives against, any claims, damages, costs, losses, or liabilities arising out of your use of these resources. Renesas' products are provided only subject to Renesas' Terms and Conditions of Sale or other applicable terms agreed to in writing. No use of any Renesas resources expands or otherwise alters any applicable warranties or warranty disclaimers for these products.

(Disclaimer Rev.1.0 Mar 2020)

### Corporate Headquarters

TOYOSU FORESIA, 3-2-24 Toyosu,  
Koto-ku, Tokyo 135-0061, Japan  
[www.renesas.com](http://www.renesas.com)

### Contact Information

For further information on a product, technology, the most up-to-date version of a document, or your nearest sales office, please visit:  
[www.renesas.com/contact/](http://www.renesas.com/contact/)

### Trademarks

Renesas and the Renesas logo are trademarks of Renesas Electronics Corporation. All trademarks and registered trademarks are the property of their respective owners.