

RAA211803, RAA211805

80V, 300mA, 5.5µA I_Q DC/DC Step-Down Regulator

The RAA211803 and RAA211805 are easy-to-use, ultra-low quiescent current (I_Q) buck regulators with a wide input voltage range of 7V to 80V and up to 300mA output current. RAA211803 has a fixed output voltage of 3.3V, and the RAA211805 output voltage is 5V.

The devices offer comprehensive protections, including V_{IN} UVLO, V_{OUT} OVP, overcurrent, and over-temperature protections.

The devices are offered in a TSOT23-5 package.

Applications

- General purpose or LDO replacement
- Industrial power supplies
- Embedded systems and I/O supplies
- E-Bikes, Power Tools
- Home/Industrial Automation

Features

- 7V to 80V input supply range
- Up to 300mA output current
- I_Q = 5.5µA at 80V, at no load conditions, switching
- I_Q = 4.5µA at 80V at no load and no switching conditions
- RAA211803 is fixed 3.3V V_{OUT}, RAA211805 is fixed 5V V_{OUT}
- Minimum on-time of 75ns
- Variable frequency operation, frequency programmed by external inductor (10µH to 33µH)
- Pre-bias, monotonic, and smooth start-up
- Protections: Overcurrent (OC) Limit, input Undervoltage Lockout (UVLO), Over-Temperature Protection (OTP), output Overvoltage Protection (OVP)
- Accurate EN threshold
- Package: TSOT23-5 (2.9mm×1.63mm)

Programmable Features

- Inductor: Change switching frequency
- Enable: Turn on/off with external logic or connect EN to V_{IN}

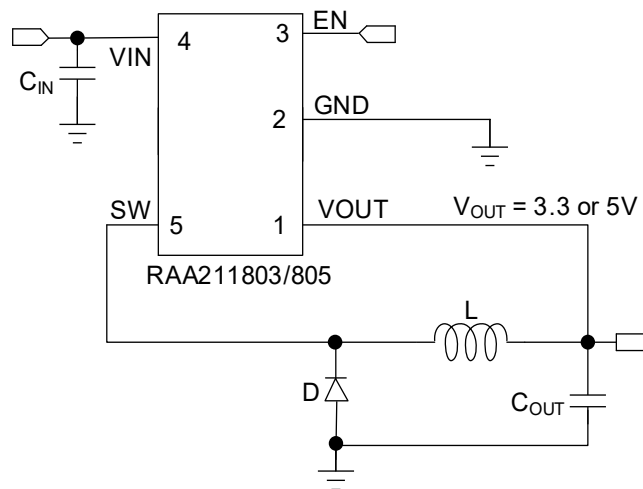

Figure 1. Typical Application Circuit

Contents

1. Overview	3
1.1 Block Diagram	3
1.2 Typical Applications	4
2. Pin Information	6
2.1 Pin Assignments	6
2.2 Pin Descriptions	6
3. Specifications	7
3.1 Absolute Maximum Ratings	7
3.2 Recommended Operating Conditions	7
3.3 Thermal Specifications	7
3.4 Electrical Specifications	8
4. Typical Performance Graphs	9
5. Functional Description	14
5.1 Peak Current and Propagation Delay	14
5.2 Soft-Start	15
5.3 Undervoltage Lockout	16
5.4 Enable Control	17
5.5 Overcurrent Protection (OCP)	18
5.6 Short Circuit	18
5.7 V_{OUT} Overvoltage Protection (OVP)	18
5.8 Pre-Biased Output Voltage	18
5.9 Over-Temperature Protection (OTP)	18
5.10 Switching Frequency	19
5.11 Fault Summary	20
6. Component Selection	20
6.1 Input Capacitor	20
6.2 Output Capacitor	21
6.3 Inductor	21
6.4 Diode	21
7. Layout Guidelines	22
8. Package Outline Drawing	23
9. Ordering Information	24
10. Revision History	24

1. Overview

1.1 Block Diagram

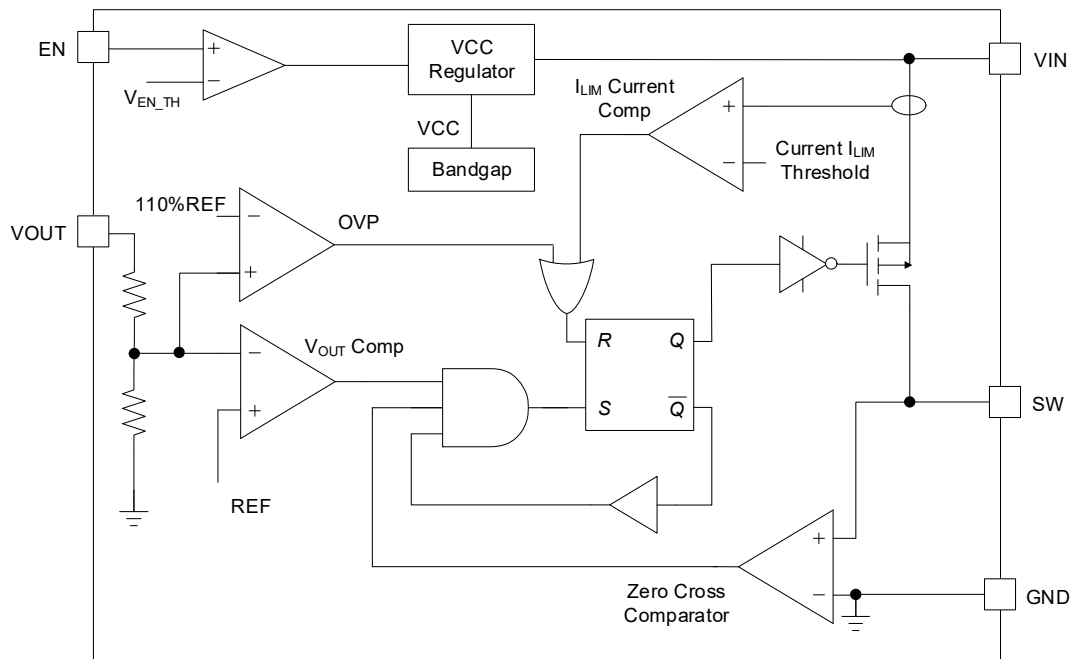

Figure 2. Block Diagram

1.2 Typical Applications

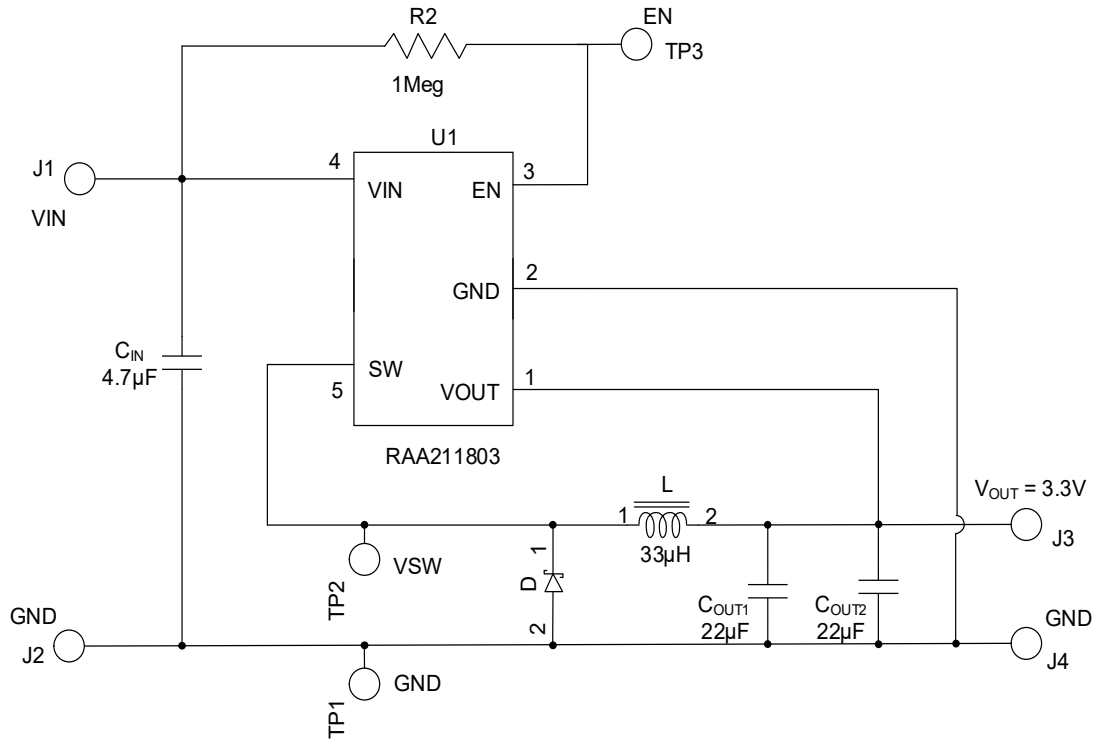

Figure 3. Typical Application Circuit (RAA211803)

Table 1. Typical BOM for RAA211803

Reference Designator	Description	Manufacturer	Manufacturer Part Number
L	COIL-PWR Inductor, SMD, 5mm, 33µH, 20%, 1.4A, 188mΩ DCR, WW, ROHS	Wurth	74404054330
CIN	Multilayer Cap, SMD, 1206, 4.7µF, 10%, 100V	Murata	GRM31CC72A475KE11L
R	Thick Film Chip Resistor, SMD, 0603, 1M, 1%, 1/10W	Generic	Various
D	0.5A 100V Low Vf Schottky Barrier Rectifier, SOD323	Panjit	BAS100CS_R1_00001
COUT1	Multilayer Cap, SMD, 0603, 22µF, 20%, 10V	Generic	Various
COUT2	Multilayer Cap, SMD, 0603, 22µF, 20%, 10V	Generic	Various

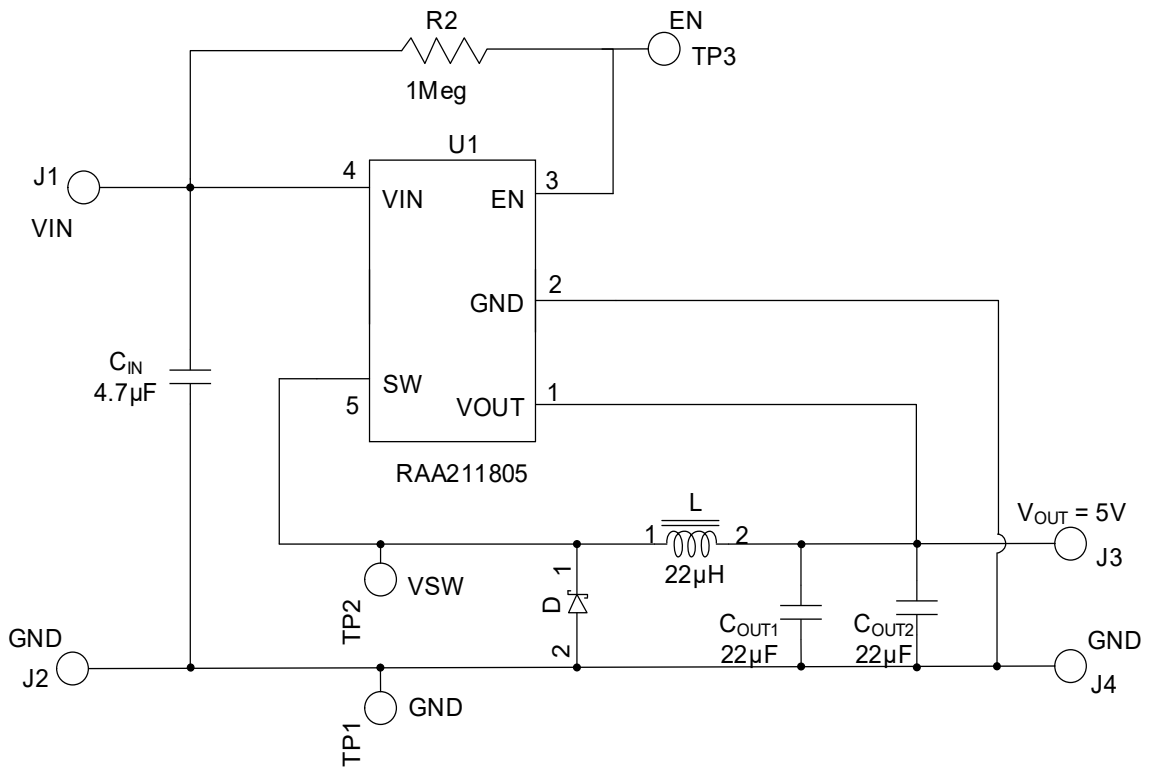

Figure 4. Typical Application Circuit (RAA211805)

Table 2. Typical BOM for RAA211805

Reference Designator	Description	Manufacturer	Manufacturer Part Number
L	COIL-PWR Inductor, SMD, 5mm, 22µH, 20%, 1.35A, 225mΩ DCR, WW, ROHS	Würth	74404052220
CIN	Multilayer Cap, SMD, 1206, 4.7µF, 10%, 100V	Murata	GRM31CC72A475KE11L
R	Thick Film Chip Resistor, SMD, 0603, 1M, 1%, 1/10W	Generic	Various
D	0.5A 100V Low Vf Schottky Barrier Rectifier, SOD323	Panjit	BAS100CS_R1_00001
COUT1	Multilayer Cap, SMD, 0805, 22µF, 20%, 16V	Generic	Various
COUT2	Multilayer Cap, SMD, 0805, 22µF, 20%, 16V	Generic	Various

2. Pin Information

2.1 Pin Assignments

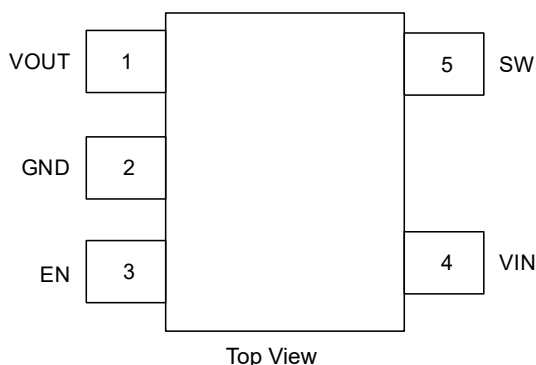

2.2 Pin Descriptions

Pin Number	Pin Name	Description
1	VOUT	Connect this pin to the output voltage of the regulator. This pin is also the bias supply for the IC after the device starts up and is in regulation.
2	GND	Ground connection pin.
3	EN	The enable pin: It is high voltage tolerant; therefore, it can be directly connected to VIN or a logic voltage for enable and disable. Do not leave this pin floating.
4	VIN	Voltage input for the IC. The VIN pin is connected to the integrated MOSFET source and to a suitable voltage source within the IC operation range to this pin.
5	SW	Switch node pin. This pin is the phase node of the regulator and is connected to the drain of the integrated MOSFET. Connect this pin to the inductor and diode.

3. Specifications

3.1 Absolute Maximum Ratings

Caution: Do not operate at or near the maximum ratings listed for extended periods of time. Exposure to such conditions can adversely impact product reliability and result in failures not covered by warranty.

Parameter	Minimum	Maximum	Unit
V _{IN}	-0.3	84	V
EN	-0.3	V _{IN} + 0.3	V
SW	-0.3	V _{IN} + 0.3	V
V _{OUT}	-0.3	7	V
SW, 20ns Transient	-6	V _{IN} + 0.3	V
Maximum Operating Junction Temperature	-40	150	°C
Maximum Storage Temperature Range	-65	150	°C
Human Body Model (Tested per JS-001-2017)	-	2	kV
Charged Device Model (Tested per JS-002-2018)	-	1	kV
Latch-Up (Tested per JESD78E; Class 2, Level A)	-	100	mA

3.2 Recommended Operating Conditions

Parameter	Minimum	Maximum	Unit
Input Voltage, V _{IN}	7	80	V
Output Current, I _{OUT}	0	0.3	A
Junction Temperature, T _J	-40	+125	°C

3.3 Thermal Specifications

Parameter	Package	Symbol	Conditions	Typical Value	Unit
Thermal Resistance	TSOT23-5	$\theta_{JA}^{[1]}$	Junction to ambient	85	°C/W
		$\theta_{JA}^{[2]}$	Junction to ambient	155	°C/W
		$\theta_{JC}^{[3]}$	Junction to case	58	°C/W

- $\theta_{JA}^{[1]}$ is measured in free air with the component mounted on RTKA211803DE0000BU/RTKA211805DE0000BU evaluation board.
- $\theta_{JA}^{[2]}$ is measured in free air with the component mounted on a high-effective thermal conductivity test board. See [TB379](#).
- For $\theta_{JC}^{[3]}$, the case temperature location is the center of the package top surface.

3.4 Electrical Specifications

$T_J = -40^{\circ}\text{C}$ to $+125^{\circ}\text{C}$, $V_{IN} = 7\text{V}$ to 80V , unless otherwise noted. Typical values are at $T_A = +25^{\circ}\text{C}$. **Boldface limits apply across the junction temperature range, -40°C to $+125^{\circ}\text{C}$.**

Parameter	Symbol	Test Conditions	Min ^[1]	Typ	Max ^[1]	Unit
Supply Voltage						
V_{IN} Voltage Range	V_{IN}	-	7	18	80	V
V_{IN} Quiescent Current	I_Q	EN = $V_{IN} = 80\text{V}$, $V_{OUT} = 3.3\text{V}$ or 5V , no load operation, switching	-	5.5	-	μA
		EN = $V_{IN} = 80\text{V}$, $V_{OUT} > 3.3\text{V}$ or 5V , no load, no switching	-	4.5	-	μA
Shutdown Current (Typ/Max)	I_{SH}	EN = 0V , $V_{IN} = 24$, no switching	-	0.3	2	μA
V_{IN} Undervoltage Lockout	-	V_{IN} rising	6	6.5	7	V
V_{IN} Undervoltage Hysteresis	-		-	550	-	mV
Output Voltage						
V_{OUT} Valley Comparator Threshold	V_{OUT}	RAA211803, $V_{IN} = 12\text{V}$, no load	3.18	3.3	3.42	V
		RAA211805, $V_{IN} = 12\text{V}$, no load	4.75	4.95	5.15	V
Overvoltage Protection	OVP	RAA211803	-	3.63	-	V
		RAA211805	-	5.5	-	V
Enable Voltage						
EN High Level Input Voltage	V_{ENH}	-	2.44	2.55	2.7	V
EN Hysteresis	-	-	-	110	-	mV
EN Leakage Current	-	EN = $V_{IN} = 80\text{V}$	-	0	-	μA
Timer Control						
Minimum On-Time	t_{ON_MIN}	$V_{IN} = 20\text{V}$	-	75	-	ns
Internal Integrated MOSFETs						
On Resistance	$r_{DS(ON)_H}$	$V_{IN} = 12\text{V}$	-	2.9	-	Ω
Current Limit and Protection						
Current Limit	I_{LIM}	$V_{IN} = 12\text{V}$	-	0.75	-	A
Current Limit Prop Delay	-	-	-	50	-	ns
Thermal Shutdown	TSD	-	-	160	-	$^{\circ}\text{C}$
Thermal Hysteresis	ΔTSD	-	-	20	-	$^{\circ}\text{C}$

- Parameters with MIN and/or MAX limits are 100% tested at $+25^{\circ}\text{C}$, unless otherwise specified. Temperature limits established by characterization and are not production tested.

4. Typical Performance Graphs

$V_{IN} = 24V$, $V_{OUT} = 3.3$ or $5V$, $I_{OUT} = 300mA$, $L = 22\mu H$ (RAA211803), $L = 33\mu H$ (RAA211805), $C_{OUT} = 2 \times 22\mu F$, $T_A = +25^\circ C$, unless otherwise stated.

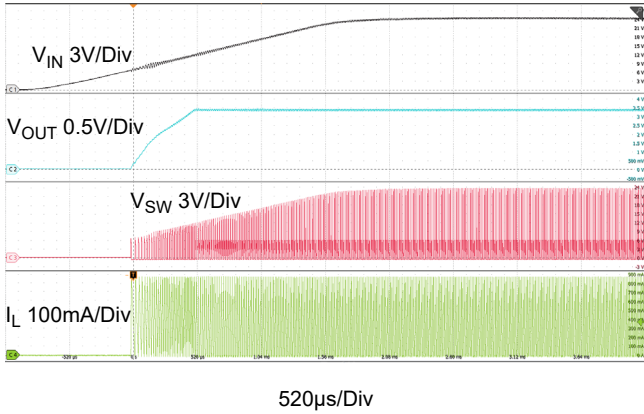

Figure 5. Startup through VIN: RAA211803

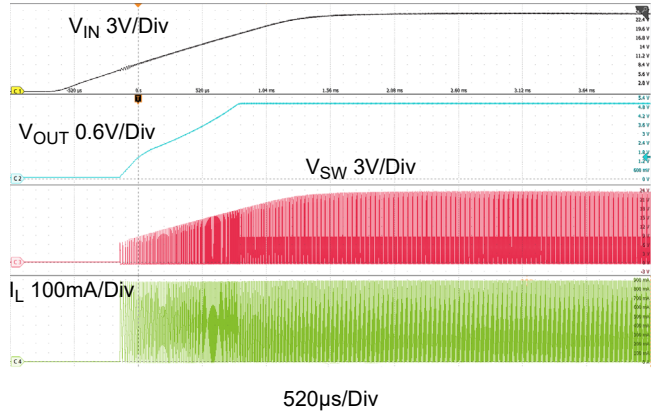

Figure 6. Startup through VIN: RAA211805

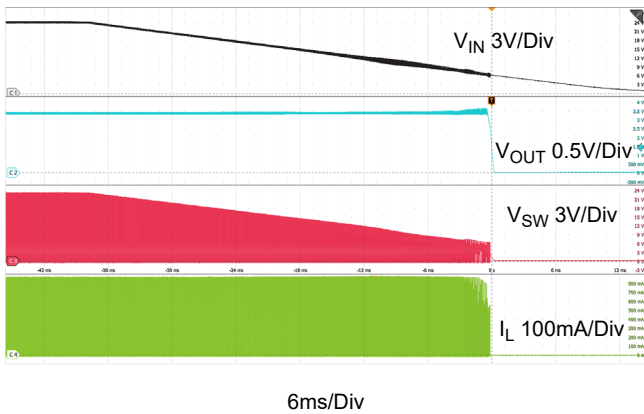

Figure 7. Shutdown through VIN: RAA211803

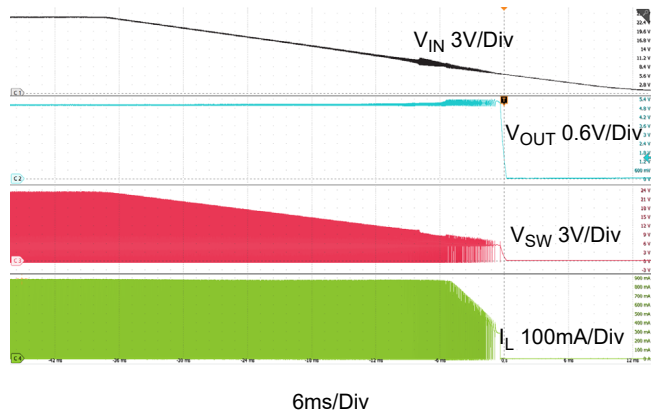

Figure 8. Shutdown through VIN: RAA211805

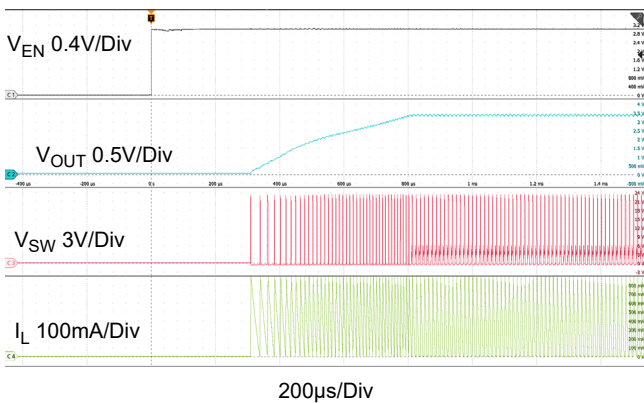

Figure 9. Startup through EN: RAA211803

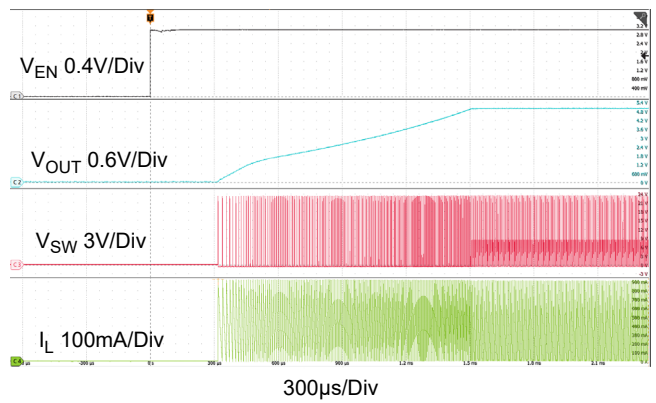

Figure 10. Startup through EN: RAA211805

$V_{IN} = 24V$, $V_{OUT} = 3.3$ or $5V$, $I_{OUT} = 300mA$, $L = 22\mu H$ (RAA211803), $L = 33\mu H$ (RAA211805), $C_{OUT} = 2 \times 22\mu F$, $T_A = +25^\circ C$, unless otherwise stated. (Cont.)

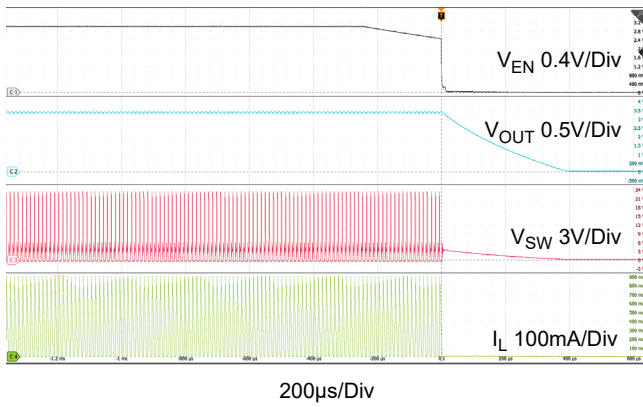

Figure 11. Shutdown through EN: RAA211803

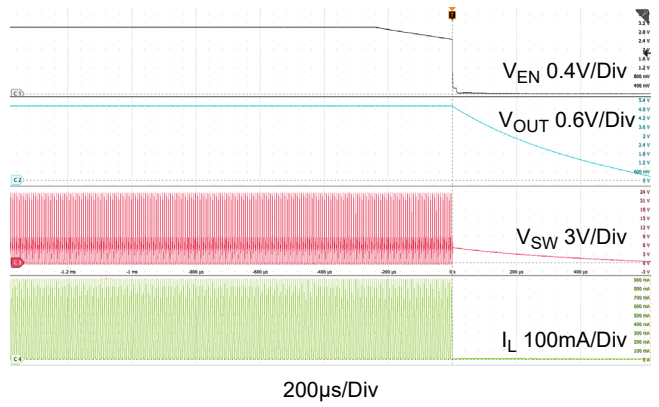

Figure 12. Shutdown through EN: RAA211805

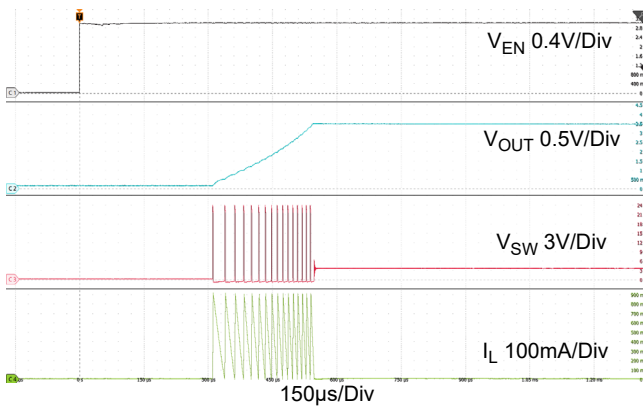

Figure 13. Startup through EN (No Load): RAA211803

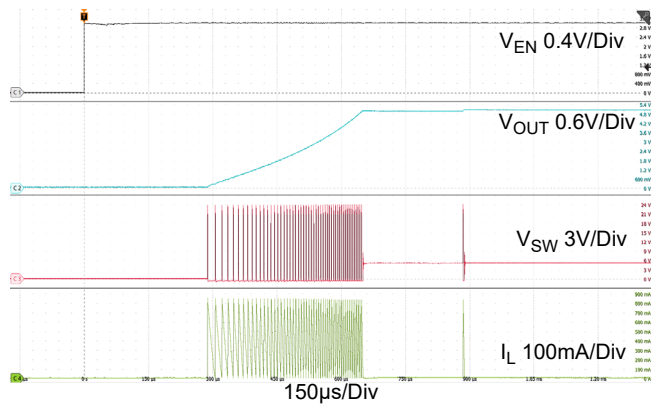

Figure 14. Shutdown through EN (No Load): RAA211805

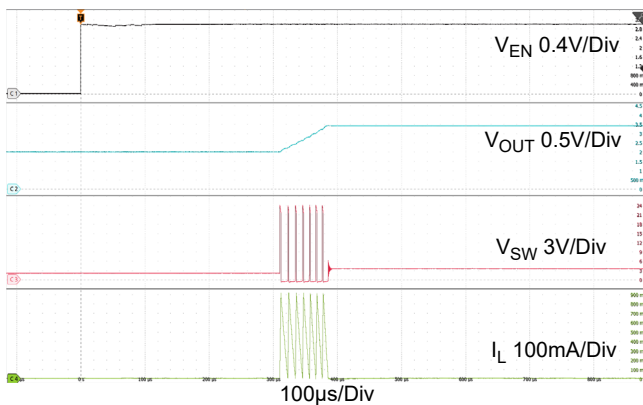

Figure 15. Startup through EN with Pre-biased (2V) Output Voltage (No Load): RAA211803

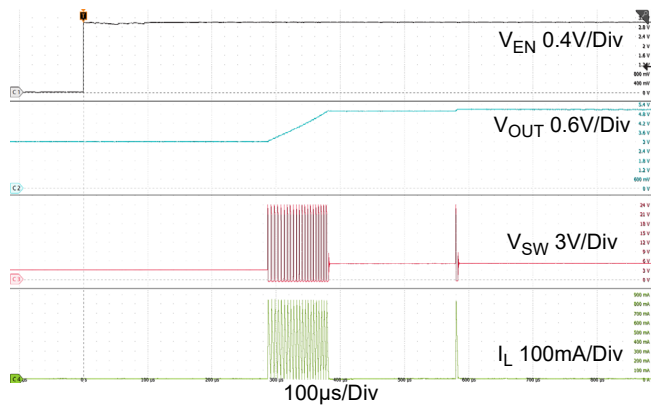

Figure 16. Startup through EN with Pre-biased (3V) Output Voltage (No Load): RAA211805

$V_{IN} = 24V$, $V_{OUT} = 3.3$ or $5V$, $I_{OUT} = 300mA$, $L = 22\mu H$ (RAA211803), $L = 33\mu H$ (RAA211805), $C_{OUT} = 2 \times 22\mu F$, $T_A = +25^\circ C$, unless otherwise stated. (Cont.)

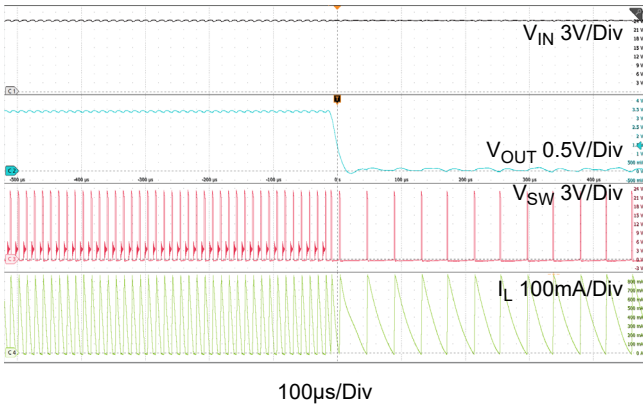

Figure 17. Short-Circuit: RAA211803

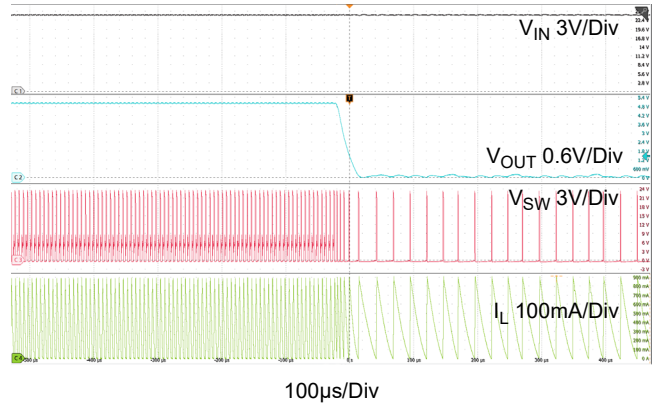

Figure 18. Short-Circuit: RAA211805

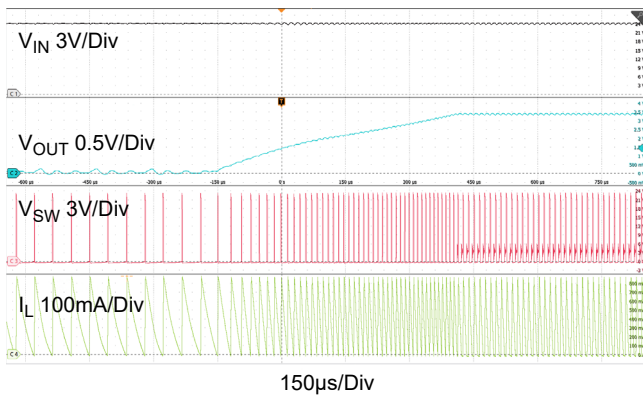

Figure 19. Recovery from Short-Circuit and startup to Full Load: RAA211803

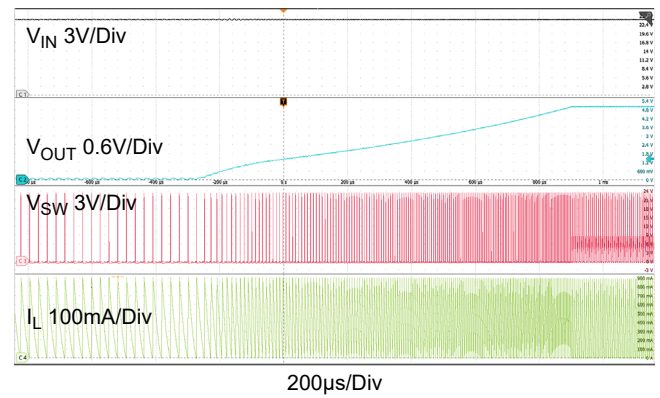

Figure 20. Recovery from Short-Circuit and startup to Full Load: RAA211805

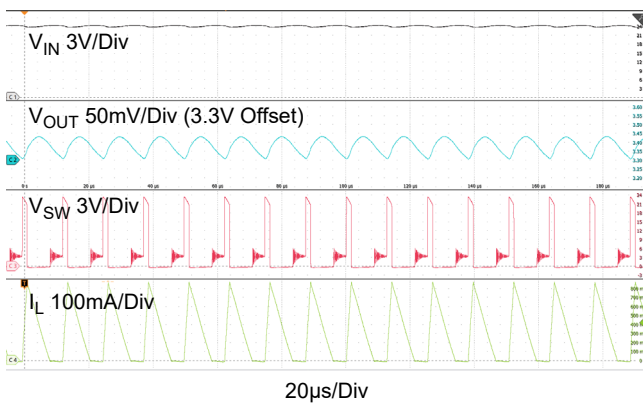

Figure 21. Typical Operation (Full Load): RAA211803

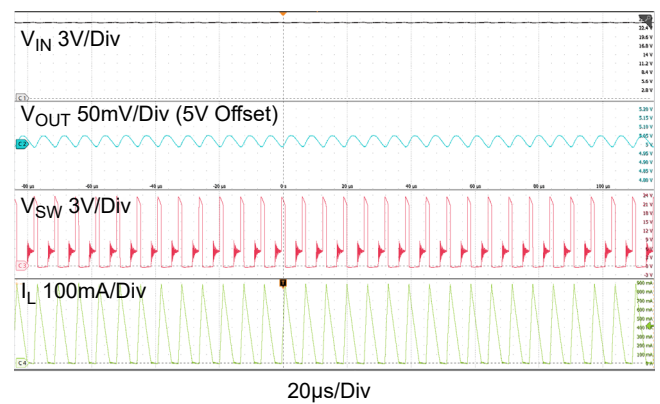

Figure 22. Typical Operation (Full Load): RAA211805

$V_{IN} = 24V$, $V_{OUT} = 3.3$ or $5V$, $I_{OUT} = 300mA$, $L = 22\mu H$ (RAA211803), $L = 33\mu H$ (RAA211805), $C_{OUT} = 2 \times 22\mu F$, $T_A = +25^\circ C$, unless otherwise stated. (Cont.)

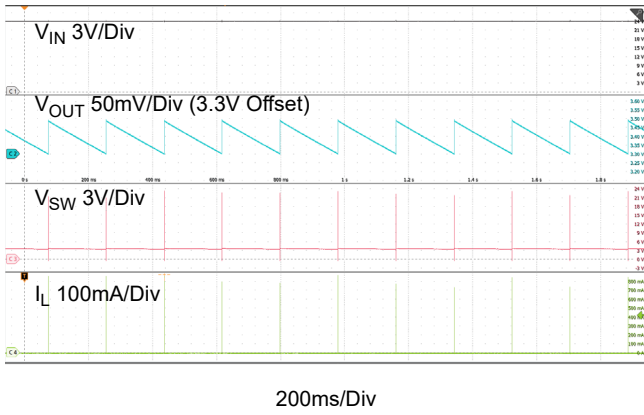

Figure 23. Typical Operation (No Load): RAA211803

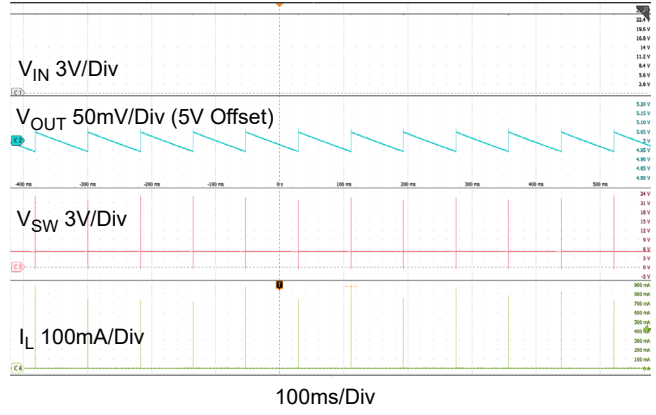

Figure 24. Typical Operation (No Load): RAA211805

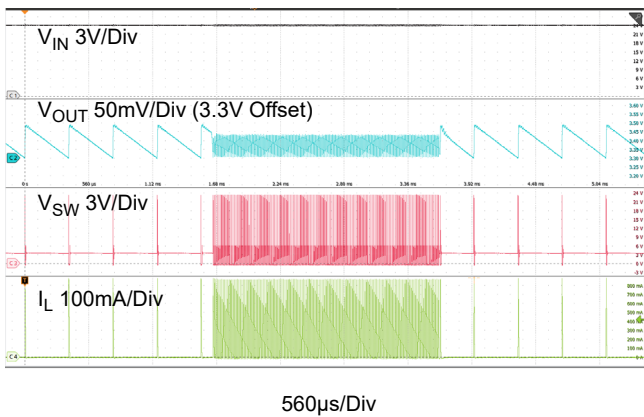

Figure 25. Load Transient (10mA to 300mA): RAA211803

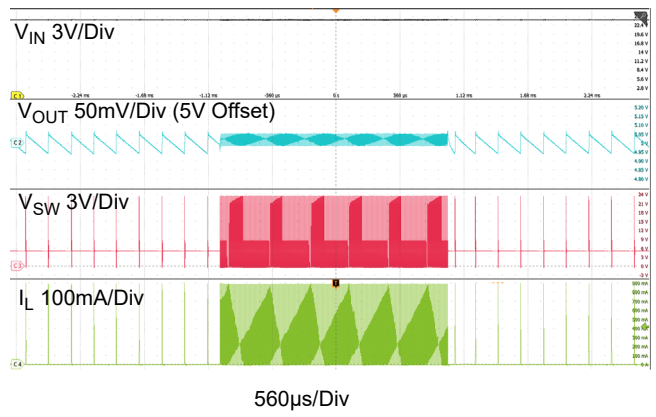

Figure 26. Load Transient (10mA to 300mA): RAA211805

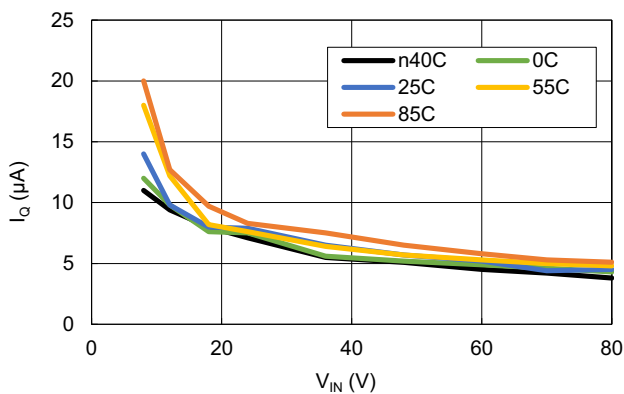

Figure 27. I_Q vs V_{IN} (In Regulation, No Load): RAA211803

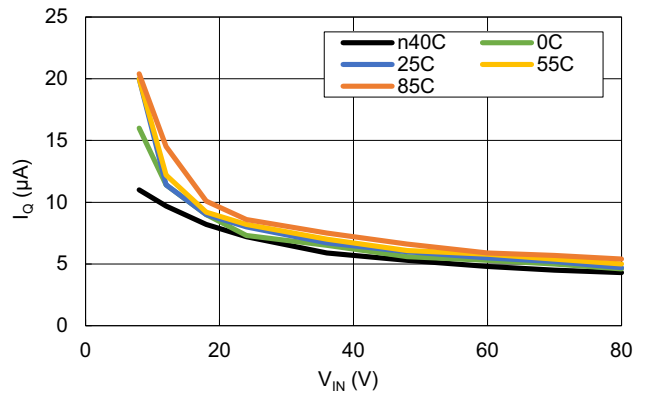

Figure 28. I_Q vs V_{IN} (In Regulation, No Load): RAA211805

$V_{IN} = 24V$, $V_{OUT} = 3.3$ or $5V$, $I_{OUT} = 300mA$, $L = 22\mu H$ (RAA211803), $L = 33\mu H$ (RAA211805), $C_{OUT} = 2 \times 22\mu F$, $T_A = +25^\circ C$, unless otherwise stated. (Cont.)

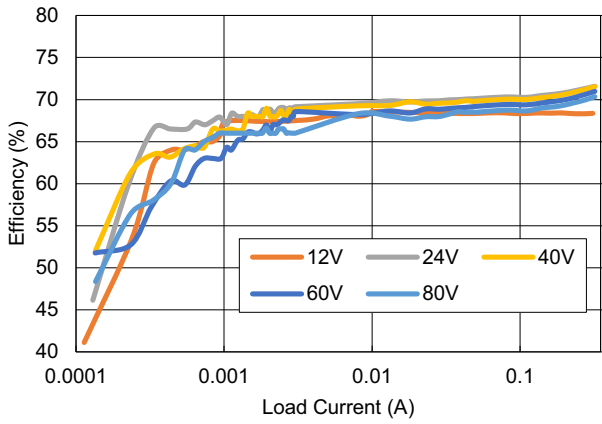

Figure 29. Efficiency: RAA211803

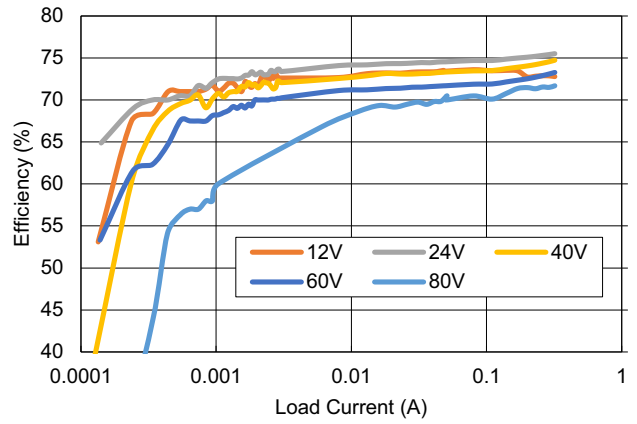

Figure 30. Efficiency: RAA211805

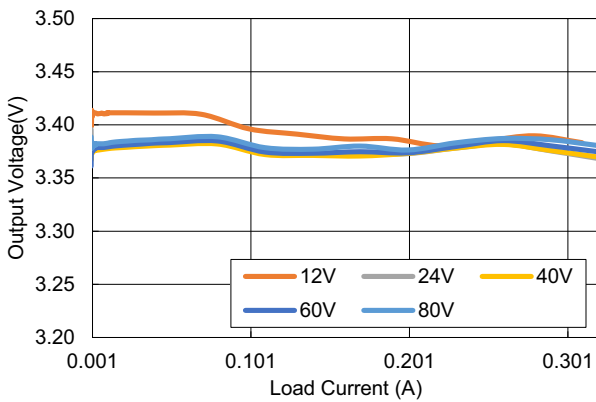

Figure 31. Load Regulation: RAA211803

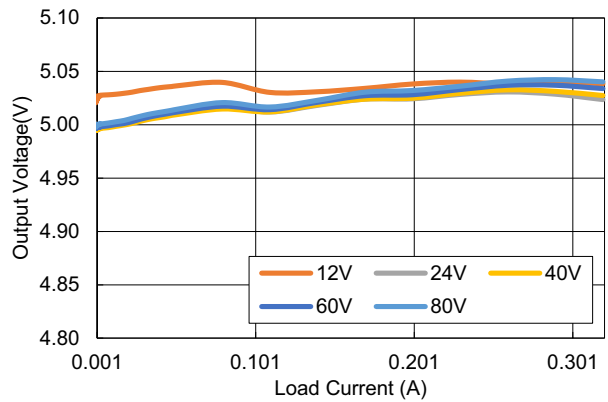

Figure 32. Load Regulation: RAA211805

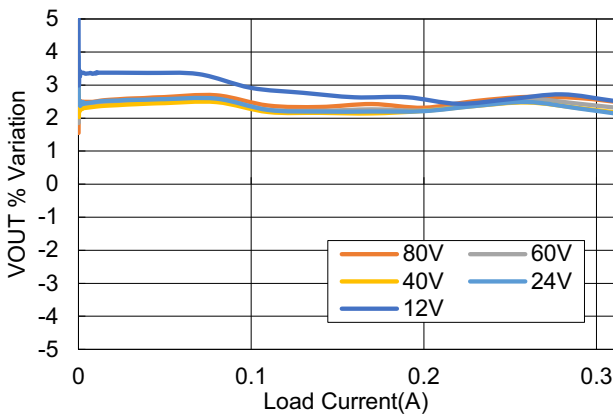

Figure 33. V_{OUT} Variation: RAA211803

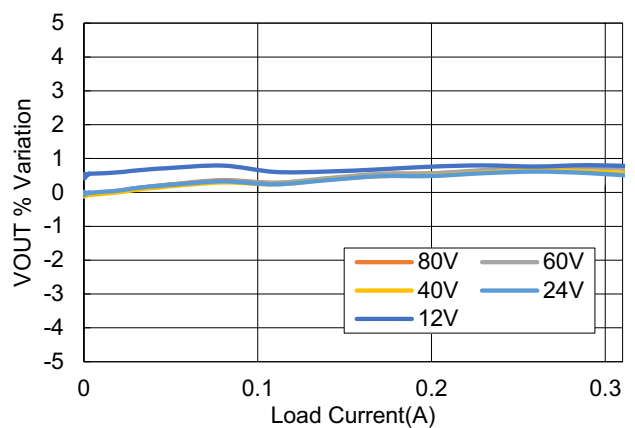

Figure 34. V_{OUT} Variation: RAA211805

5. Functional Description

The RAA211803 and RAA211805 are each an easy-to-use 300mA low I_Q step-down regulator with a wide input voltage range of 7V to 80V across the -40°C to 125°C junction temperature range.

The regulators start switching when the input and enable voltage reaches their thresholds. They use a fixed current reference to turn the MOSFET off and an output voltage valley threshold to turn the MOSFET back on. The following describes the operation of the regulators.

The output voltage is sensed on the VOUT pin through internal feedback resistors and is compared with the internal reference of 1.2V to produce the control signal, which decides when to turn on the MOSFET. The MOSFET is switched on when the following conditions are met:

- The inductor current hits zero
- The output voltage drops below a fixed V_{OUT} threshold

When the MOSFET is on, the inductor current rises linearly depending on the inductor and input voltage values. The MOSFET is switched off when the inductor current reaches the fixed I_{LIM} current threshold of 750mA (typical). Therefore, the regulators always operate in discontinuous current mode and need V_{OUT} ripple for the control scheme to function.

The switching frequency can be programmed by changing the inductor value. The operating frequency depends on the inductor, the input voltage, and the load current (see [Figure 45](#) to [Figure 50](#)). As the peak current is fixed for a particular input voltage, the switching frequency is tied to the load. The charge (or current) in each switching cycle is fixed. Therefore, an increase in the load current is met by an increase in the switching frequency.

The no-load switching quiescent current at input 80V is 5.5µA.

5.1 Peak Current and Propagation Delay

The regulators control the inductor peak current at 750mA (typical). However, because of the current sensor propagation delay, the peak current tends to be higher than 750mA. The propagation delay is typically 50ns.

Use [Equation 1](#) to approximately calculate the actual inductor peak current.

$$(EQ. 1) \quad I_{peak} = 0.750 + 50 \times 10^{-9} \times \frac{(V_{IN} - V_{OUT})}{L}$$

In addition, the regulator has a minimum MOSFET turn-on time. Therefore, choosing too small of an inductance value may result in a peak current higher than predicted by [Equation 1](#). Renesas recommends a minimum inductance of 10µH or higher. [Figure 35](#) and [Figure 36](#) show the peak inductor current versus input voltage graphs for a few recommended inductors.

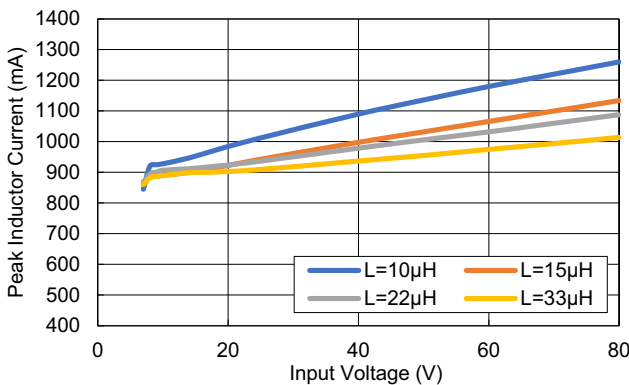

Figure 35. Peak Inductor Current: RAA211803

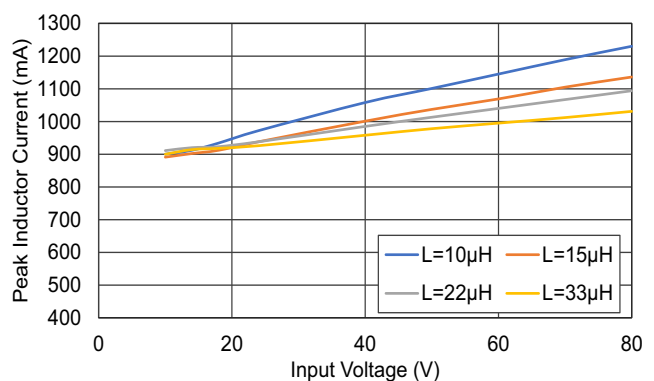

Figure 36. Peak Inductor Current: RAA211805

5.2 Soft-Start

The RAA211803 and RAA211805 are naturally current-limited and automatically provide a smoothly rising V_{OUT} voltage on power-up. Because the total output load of the device is limited, a startup with a heavy load generates a longer V_{OUT} ramp, and a startup with no load generates a faster ramp.

Soft-start time is approximately defined by Equation 2.

$$(EQ. 2) \quad \text{Soft-Start Time} = V_{OUT} \times \left[\frac{C_{OUT}}{\left(\frac{I_{peak}}{2}\right) - I_{LOAD}} \right]$$

The approximate soft-start time based on the evaluation boards (RTKA211803DE00BU and RTKA211805DE00BU) is given in Table 3, Table 4, and Figure 37 to Figure 42.

Table 3. Approximate Soft-Start Times (RAA211803)

Inductor (μH)	Soft-Start Time (No Load) ^[1] (μs)	Soft-Start Time (Full Load) ^[1] (μs)
33	265	440
22	260	430
15	250	400
10	230	350

1. Test conditions: V_{IN} = 24V, C_{OUT} = 2x22μF (PN:GRM187R61A226ME15), L = 33μH (PN:74404054330), Power supply: Chroma-632012P-100-50, Load: Resistive Load equivalent to full load at nominal V_{OUT}, measured through 0 to 100% of nominal V_{OUT}

Table 4. Approximate Soft-Start Times (RAA211805)

Inductor (μH)	Soft-Start Time (No Load) ^[1] (μs)	Soft-Start Time (Full Load) ^[1] (μs)
33	360	550
22	360	590
15	340	540
10	355	540

1. Test conditions: V_{IN} = 24V, C_{OUT} = 2x22μF (PN:GRM219R61C226ME15), L = 22μH (PN:74404052220), Power supply: Chroma-632012P-100-50, Load: Resistive Load equivalent to full load at nominal V_{OUT}, measured through 0 to 100% of nominal V_{OUT}

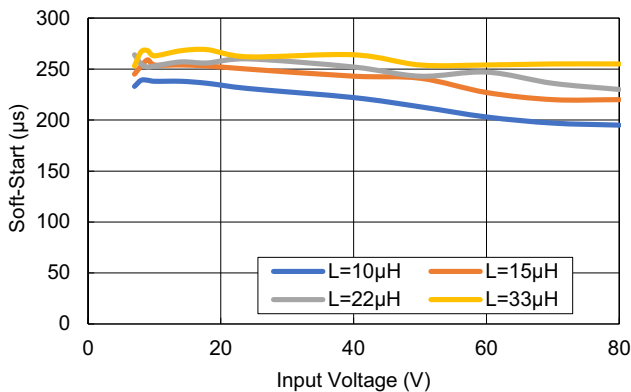

Figure 37. Soft-Start (No Load): RAA211803

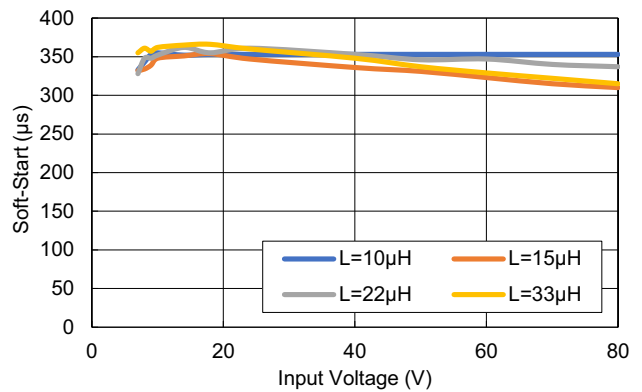

Figure 38. Soft-Start (No Load): RAA211805

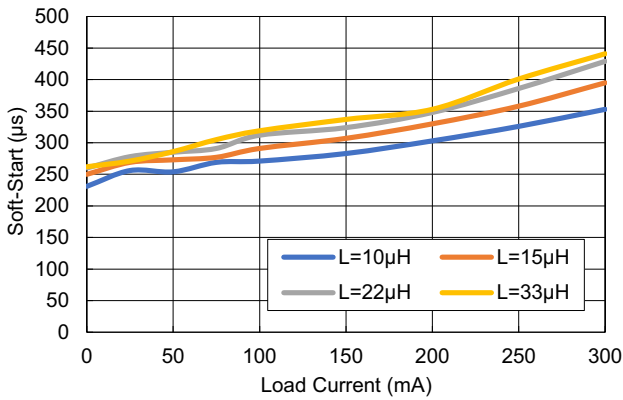

Figure 39. Soft-Start ($V_{IN} = 24V$): RAA211803

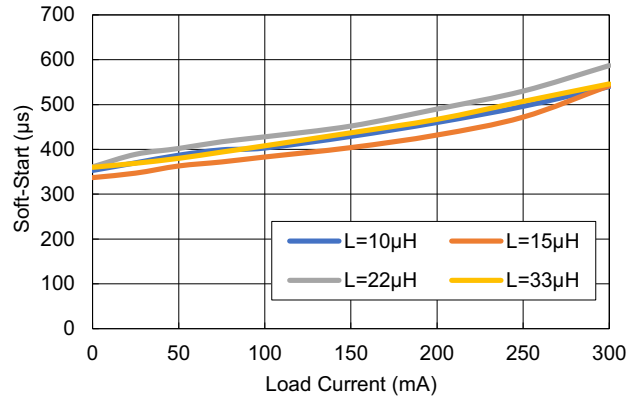

Figure 40. Soft-Start ($V_{IN} = 24V$): RAA211805

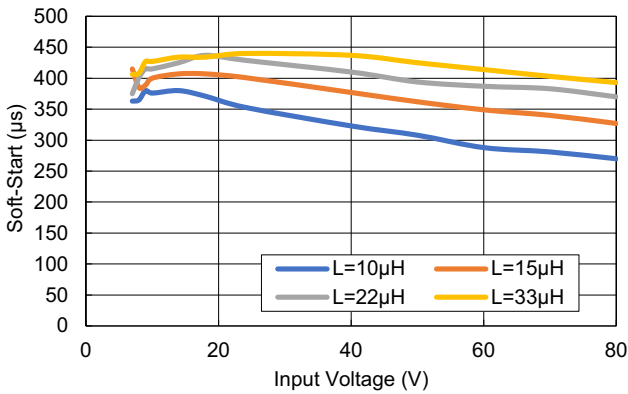

Figure 41. Soft-Start (Resistive Full Load): RAA211803

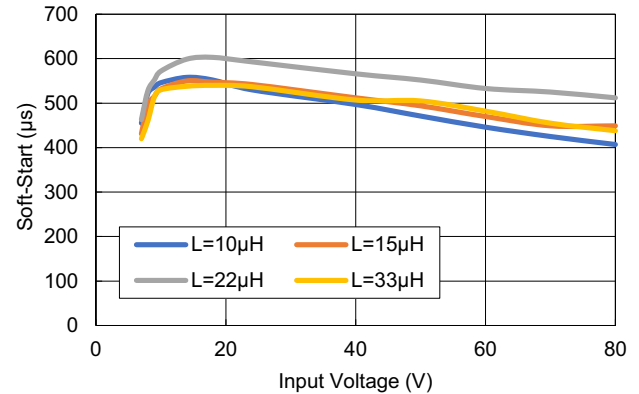

Figure 42. Soft-Start (Resistive Full Load): RAA211805

5.3 Undervoltage Lockout

The devices have an Undervoltage Lockout (UVLO) on the VIN pin. It prevents the regulators from starting until the input voltage exceeds 6.5V (typical). The UVLO threshold has approximately 550mV of hysteresis. Therefore, the device continues to operate when the VIN decreases until it drops below 5.95V (typical). Hysteresis prevents the part from turning off during power-up if the VIN is non-monotonic. Renesas recommends making the current path length from the VIN power supply or the upstream input power supply to the IC as small as possible to prevent jittering during VIN turn-off and turn-on.

5.4 Enable Control

The devices have an enable pin that turns them on when pulled high. When EN is low, the ICs shut down (see [Figure 9](#) and [Figure 12](#)). They have an EN rising threshold voltage of 2.55V (typical). EN threshold hysteresis is 110mV (typical).

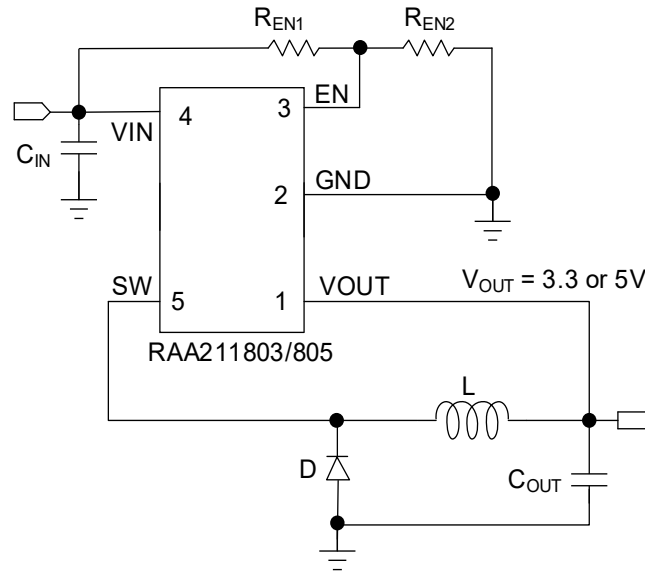

Figure 43. Typical Application Circuit Diagram with V_{IN} UVLO Programming by ENABLE

The EN pin can be tied directly to VIN for always-on operation. The devices have an accurate Enable threshold that allows you to program the V_{IN} UVLO threshold by connecting V_{IN} to EN using a resistor divider. The UVLO can be set with the resistor divider based on [Equation 3](#), where V_{INR} is the rising threshold of V_{IN} UVLO (see [Figure 43](#)).

$$(EQ. 3) \quad \frac{R_{EN1}}{R_{EN2}} = \left(\frac{V_{INR} - 2.55}{2.55} \right)$$

Calculate the resulting input voltage for the part to be turned off using [Equation 4](#):

$$(EQ. 4) \quad V_{INF} = 2.44 \times \frac{R_{EN1} + R_{EN2}}{R_{EN2}}$$

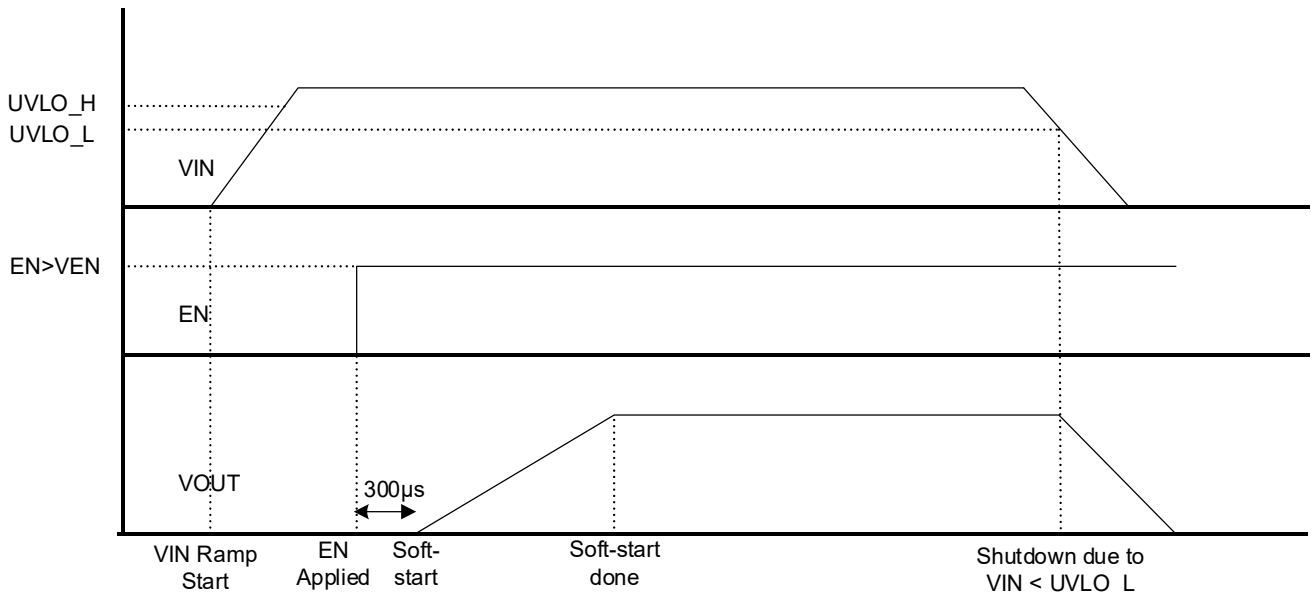

Figure 44. Timing Diagram with EN Turn-On and VIN UVLO Turn-Off

5.5 Overcurrent Protection (OCP)

RAA211803 and RAA211805 have built-in peak current protection with control. The MOSFET current is constantly monitored to turn off the MOSFET at 750mA (typical) peak current.

5.6 Short Circuit

The devices operate on boundary current mode during a short-circuit condition. The regulator still switches based on the control previously described. The output current during a short-circuit condition is given by Equation 5, and shown in Figure 17 to Figure 20:

$$(EQ. 5) \quad I_{OUT} = \frac{I_{peak}}{2}$$

5.7 V_{OUT} Overvoltage Protection (OVP)

RAA211803 and RAA211805 have an output overvoltage protection. The internal overvoltage comparator compares the FB pin with 110% of the reference voltage (see Figure 2). When this voltage exceeds 110% of the nominal, the regulator turns off the MOSFET. The MOSFET turns back on when the V_{OUT} voltage goes below the V_{OUT} valley threshold defined by the controller.

5.8 Pre-Biased Output Voltage

The part functions per the control scheme highlighted in the block diagram with an existing output voltage on the output pin. Figure 15 and Figure 16 show the start-up signals when the controller is enabled with pre-existing output voltage. The start-up is smooth, monotonic, and free from any glitches.

The part shuts off when the biased output voltage is above the valley threshold of the V_{OUT} comparator, and no switching signal is given to the FET. This feature is useful in systems with paralleled power supplies for redundancy (to maintain high reliability) without the addition of any additional circuitry. This feature can be used as a power-saving feature, as the typical I_Q of the part is 4.5µA at no load and no switching conditions.

5.9 Over-Temperature Protection (OTP)

Over-temperature protection (OTP) limits the maximum junction temperature in the devices. This protection limits total power dissipation by shutting off the regulator when the junction temperature of the ICs exceeds 160°C

(typical). There is a 20°C hysteresis for OTP. After the junction temperature drops below 140°C, the devices resume operation by stepping through soft-start.

5.10 Switching Frequency

The regulator is a variable frequency converter, and the switching frequency varies proportionally to the load. The maximum switching frequency is dependent on inductance and peak current.

Choose 33µH for a maximum frequency of approximately 170 kHz (RAA211803), and choose 22µH for a maximum frequency of 230 kHz (RAA211805). The bench data based on our evaluation boards RTKA211803DE0000BU and RTKA211805DE0000BU is shown in Figure 45 and Figure 50.

The switching frequency can be approximately given by Equation 6.

$$(EQ. 6) \quad \text{Switching Frequency} = \frac{2 \times I_{LOAD}}{L \times I_{peak} \times I_{peak} \times \left(\frac{1}{V_{IN} - V_{OUT}} + \frac{1}{V_{OUT}} \right) \times \text{Efficiency}}$$

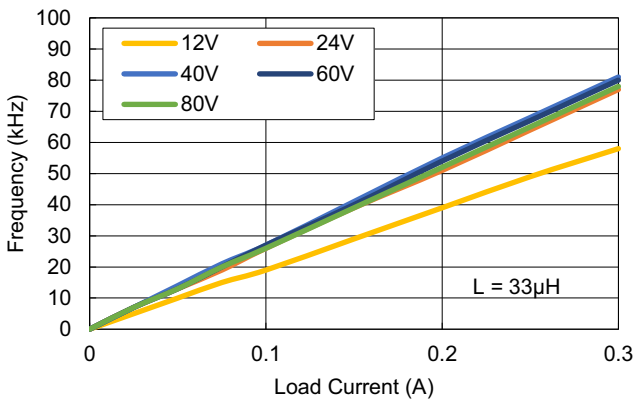

Figure 45. Switching Frequency vs Load Current RAA211803

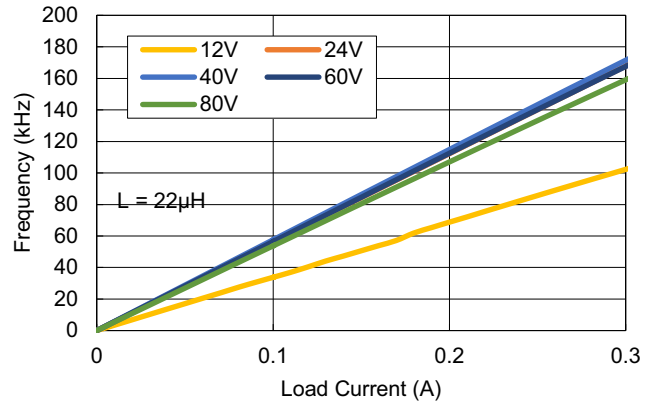

Figure 46. Switching Frequency vs Load Current RAA211805

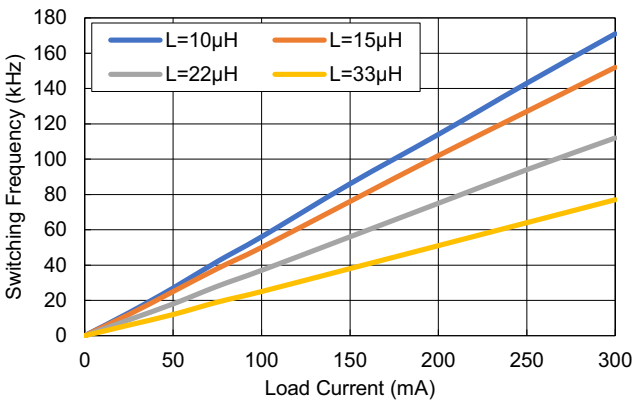

Figure 47. Switching Frequency vs Load Current VIN = 24V: RAA211803

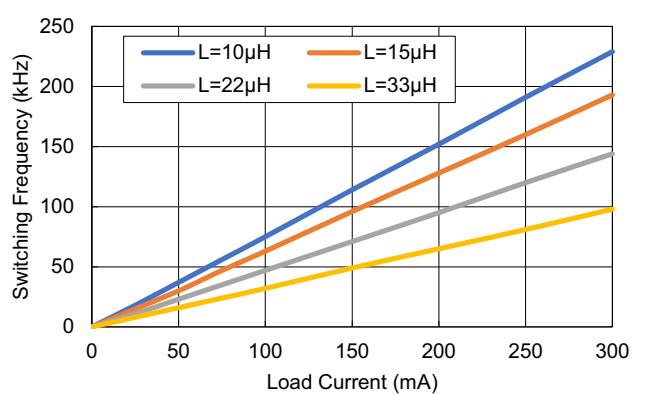

Figure 48. Switching Frequency vs Load Current VIN = 24V: RAA211805

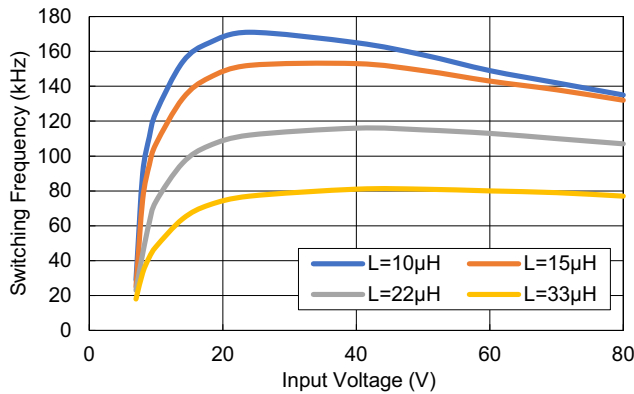

Figure 49. Switching Frequency vs Input Voltage
Full Load (300mA): RAA211803

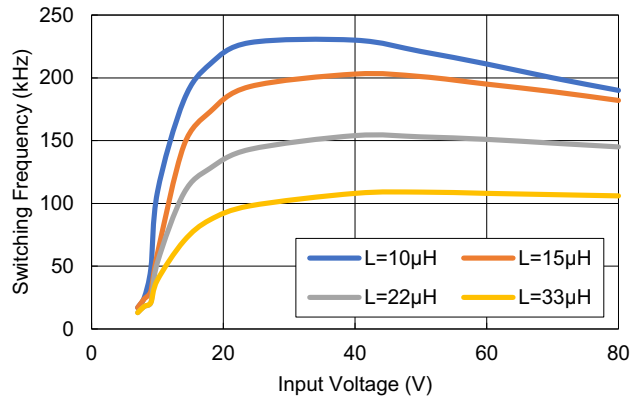

Figure 50. Switching Frequency vs Input Voltage
Full Load (300mA): RAA211805

5.11 Fault Summary

Top Level faults (VIN UVLO, OTP) stop VOUT and enter the power-on reset (POR) state until the fault is relieved; next, the chip starts normally according to the EN state.

Fault	Detection Delay	Design Implementation
V _{IN} UVLO	2µs	Power-On Reset (POR), chip restarts from initial reset state when UVLO is satisfied.
OT_shutdown	Immediate	Device shutdown and recovery after OT hysteresis is met, internal circuit monitor OT hysteresis.
Current Limit	Immediate	When the high-side MOSFET reaches current limit, the MOSFET turns off.
V _{OUT} Short	Immediate	Device operates in current limit mode.
V _{OUT} OVP	Immediate	When V _{OUT} reached the OVP limit, the MOSFET turns off.

6. Component Selection

6.1 Input Capacitor

The input capacitor in a buck converter maintains the input voltage by suppressing the voltage ripple induced by discontinuous switching current.

Renesas recommends using low ESR/low ESL ceramic capacitors across the input of the regulator. When selecting ceramic capacitors for power supply applications, it is important to consider that the effective capacitance reduces with DC bias voltage across it. Therefore, consult the capacitor datasheet to understand the impact of this effect. Renesas also recommends using X5R/X7R dielectric ceramic capacitors because of their small temperature coefficient. In addition, as RAA211803/805 are low quiescent current regulators, picking an input capacitor with a minimum voltage rating of 100V with a low leakage current is advised.

Choose an input capacitor of a minimum of 4.7µF. If the input to the regulator is fed through a high-impedance path, Renesas recommends adding an electrolytic capacitor and a ceramic capacitor to dampen the input voltage oscillation effects.

6.2 Output Capacitor

Output capacitor selection impacts the steady state and transient performance of the buck converter. Factors such as output ripple voltage, output voltage excursion during transients, and output voltage regulation should be considered when selecting the output capacitor. Renesas recommends using low ESR/low ESL X5R/X7R dielectric ceramic for the output capacitor with a minimum voltage rating of 10V for RAA211803 and 16V for RAA211805. It is important to consider that the effective capacitance reduces with DC bias voltage across it. Therefore, consult the capacitor datasheet to understand the impact of this effect. Use [Equation 7](#) to approximate the output voltage ripple, where I_{PEAK} is the peak inductor current from [Equation 1](#).

$$(EQ. 7) \quad V_{RIPPLE(C)} = \frac{L(I_{PEAK} - I_{OUT})^2}{2C_{OUT}V_{OUT}} \left(\frac{V_{IN}}{V_{IN} - V_{OUT}} \right)$$

Use [Equation 7](#) for initial capacitor selection. Select the final value based on testing a prototype board, capacitor DC bias derating, and capacitor ESR.

Output capacitance determines the output voltage ripple and V_{OUT} regulation for RAA211803 and RAA211805. Choose a minimum of 22 μ F for the smallest area or a larger output capacitor to reduce ripple and provide tighter voltage regulation (see [Figure 31](#) to [Figure 32](#)).

6.3 Inductor

Select an inductor with the lowest possible DC resistance (DCR) to minimize power losses. The continuous current rating of the inductor should be high enough to accommodate the DC load current and AC ripple current with an additional margin for overload conditions. The saturation current rating should be more than the peak inductor current. The factory recommends a minimum inductance of 10 μ H or higher with a minimum saturation current of 1A. See [Figure 35](#) and [Figure 36](#) for inductor peak current values with different inductances.

6.4 Diode

The devices require a freewheeling diode for the inductor current to flow when the internal high-side MOSFET turns off. Select a diode with a reverse voltage rating at least 20% higher than the maximum input voltage. The continuous current rating of the diode should be greater than the highest output current. Select a diode with low forward voltage drop and fast reverse recovery time for better efficiency. For operation at high temperatures, Renesas recommends using a high-quality Schottky, as diode leakage increases the current consumption of the application. Renesas recommends a minimum reverse breakdown voltage of 100V, a continuous current rating of 0.5A, and a peak current rating of 1A.

7. Layout Guidelines

The printed circuit board (PCB) layout is critical for properly operating the RAA211803 and RAA211805. The following guidelines are recommended to achieve good performance.

- Use multilayer PCB structure to achieve optimized performance. The evaluation boards RTKA211803DE0000BU and RTKA211805DE0000BU use a 2-layer PCB with 1oz copper and the bottom layer as ground.
- Place the input capacitor as close as possible to the IC. The input capacitor is the most important component for any step-down converter and should be placed first in the layout.
- The copper area of the SW node should not be more than needed. Place the inductor close to the regulator.
- Place an output capacitor close to the inductor.
- Place and route the power component to keep the power loop area minimum and short as possible.
- Keep all the power components on the same side of the PCB.
- Include thermal vias, as necessary, to improve heat dissipation.

The recommended PCB board layout example is shown in [Figure 51](#) and [Figure 52](#).

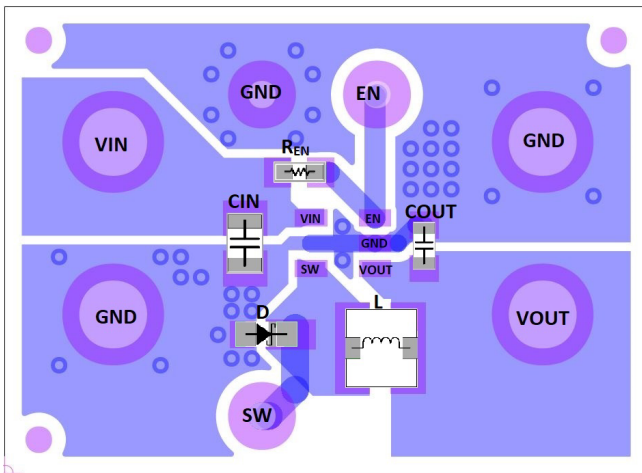

Figure 51. Layout (Top Layer)

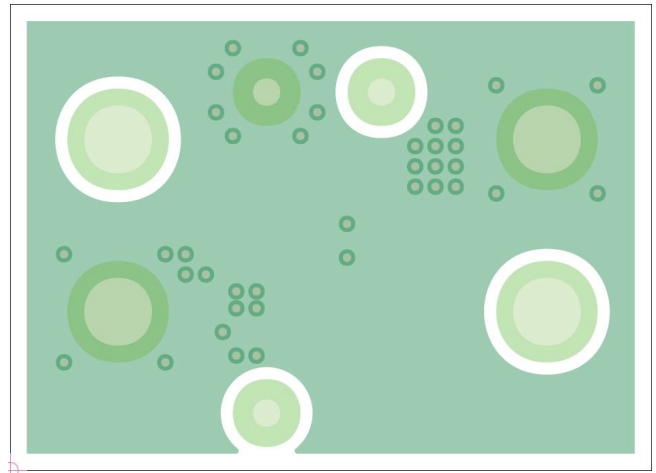

Figure 52. Layout (Bottom Layer)

8. Package Outline Drawing

For the most recent package outline drawing, see [P5.064B](#).

P5.064B

5 Lead Thin Small Outline Transistor (TSOT) Plastic Package

Rev 3, 2/2022

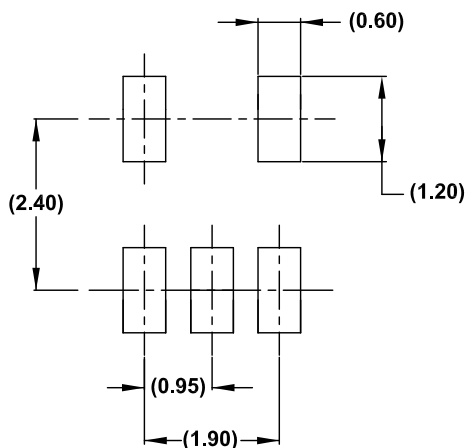
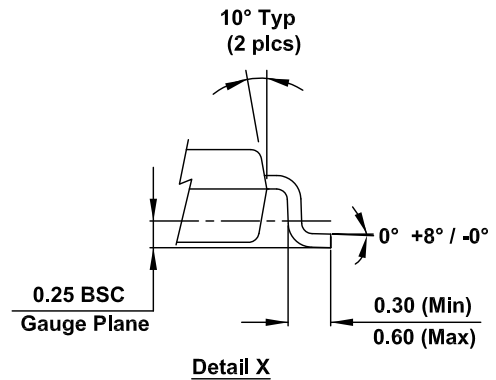
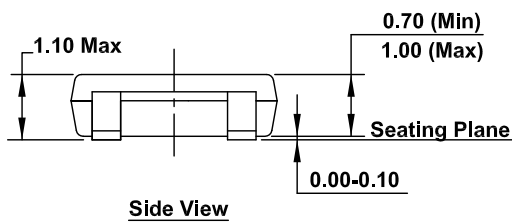
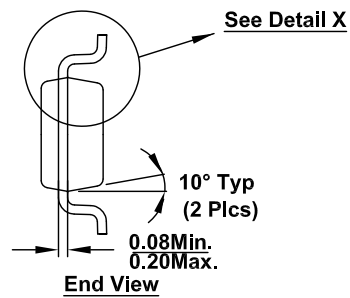
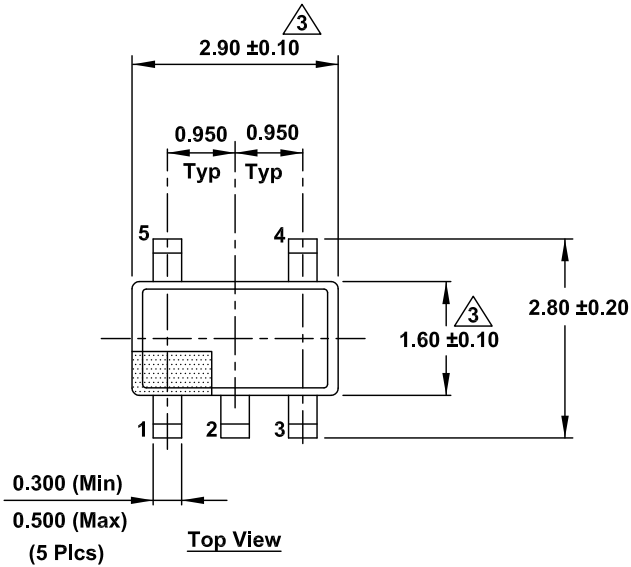

NOTE:

1. Dimensioning and tolerancing conform to ASME Y14.5m-1994.
2. Die is facing up for mold. Die is facing down for trim/form, that is reverse trim/form.
3. Dimensions are exclusive of mold flash and gate burr.
4. The footlength measuring is based on the gauge plane method.
5. All specifications comply to JEDEC Spec MO193 Issue C.

9. Ordering Information

Part Number ^{[1][2]}	Part Marking ^[3]	Package Description ^[4] (RoHS Compliant)	Pkg. Dwg #	Carrier Type ^[5]	Temp. Range
RAA2118034GP3#JA0	803	TSOT-23	P5.064B	Reel, 3k	-40 to +125°C
RAA2118054GP3#JA0	805				
RTKA211803DE0000BU	RAA211803 Evaluation Board				
RTKA211805DE0000BU	RAA211805 Evaluation Board				

1. These Pb-free plastic packaged products employ special Pb-free material sets; molding compounds/die attach materials and NiPdAu plate - e4 termination finish, which is RoHS compliant and compatible with both SnPb and Pb-free soldering operations. Pb-free products are MSL classified at Pb-free peak reflow temperatures that meet or exceed the Pb-free requirements of IPC/JEDEC J-STD-020.
2. For Moisture Sensitivity Level (MSL), see the [RAA211803](#), [RAA211805](#) product pages. For more information about MSL, see [TB363](#).
3. The part marking is located on the bottom of the part.
4. For the Pb-Free Reflow Profile, see [TB493](#).
5. See [TB347](#) for details about reel specifications.

10. Revision History

Revision	Date	Description
1.00	Oct 2, 2023	Initial release

IMPORTANT NOTICE AND DISCLAIMER

RENESAS ELECTRONICS CORPORATION AND ITS SUBSIDIARIES (“RENESAS”) PROVIDES TECHNICAL SPECIFICATIONS AND RELIABILITY DATA (INCLUDING DATASHEETS), DESIGN RESOURCES (INCLUDING REFERENCE DESIGNS), APPLICATION OR OTHER DESIGN ADVICE, WEB TOOLS, SAFETY INFORMATION, AND OTHER RESOURCES “AS IS” AND WITH ALL FAULTS, AND DISCLAIMS ALL WARRANTIES, EXPRESS OR IMPLIED, INCLUDING, WITHOUT LIMITATION, ANY IMPLIED WARRANTIES OF MERCHANTABILITY, FITNESS FOR A PARTICULAR PURPOSE, OR NON-INFRINGEMENT OF THIRD PARTY INTELLECTUAL PROPERTY RIGHTS.

These resources are intended for developers skilled in the art designing with Renesas products. You are solely responsible for (1) selecting the appropriate products for your application, (2) designing, validating, and testing your application, and (3) ensuring your application meets applicable standards, and any other safety, security, or other requirements. These resources are subject to change without notice. Renesas grants you permission to use these resources only for development of an application that uses Renesas products. Other reproduction or use of these resources is strictly prohibited. No license is granted to any other Renesas intellectual property or to any third party intellectual property. Renesas disclaims responsibility for, and you will fully indemnify Renesas and its representatives against, any claims, damages, costs, losses, or liabilities arising out of your use of these resources. Renesas' products are provided only subject to Renesas' Terms and Conditions of Sale or other applicable terms agreed to in writing. No use of any Renesas resources expands or otherwise alters any applicable warranties or warranty disclaimers for these products.

(Disclaimer Rev.1.0 Mar 2020)

Corporate Headquarters

TOYOSU FORESIA, 3-2-24 Toyosu,
Koto-ku, Tokyo 135-0061, Japan
www.renesas.com

Contact Information

For further information on a product, technology, the most up-to-date version of a document, or your nearest sales office, please visit:
www.renesas.com/contact/

Trademarks

Renesas and the Renesas logo are trademarks of Renesas Electronics Corporation. All trademarks and registered trademarks are the property of their respective owners.