

RC18016

JESD204B/C Compliant Fanout Buffers and Dividers

Description

The RC18016 is a fully integrated clock and SYSREF signal fanout buffer for JESD204B/C applications.

The device provides a high-performance clock and converter synchronization solution for wireless base station radio equipment boards with JESD204B/C subclass 0, 1, and 2 compliance. The main function of the device is the distribution and fanout of high-frequency clocks and low-frequency system reference signals generated by a JESB204B clock generator such as the [RC38612](#), extending its fanout capabilities and providing additional phase-delay. The RC18016 is optimized to deliver very low phase noise clocks and precise, phase-adjustable SYSREF synchronization signals.

The RC18016 distributes the input clock (CLK) and JESD204B SYSREF signals (REF) to four fanout channels. Input clock signals can be frequency divided and are fanned-out to multiple clock (QCLK_y) and SYSREF (QREF_r) outputs. Configurable phase-delay circuits are available for both clock and SYSREF signals. The propagation delays in all signal paths are fully deterministic to support fixed phase relationships between clock and SYSREF signals within one device. The device facilitates synchronization between frequency dividers within one device and across multiple devices, removing phase ambiguity introduced in dividers between power and configuration cycles.

Applications

- Wireless infrastructure applications: 4G, 5G, and mmWave
- Frequency divider synchronization across multiple devices
- Ideal clock driver for jitter-sensitive ADC and DAC circuits
- Radar, imaging, instrumentation, and medical

Features

- Distribution, fanout, phase-delay of clock, and SYSREF signals
- Low output noise floor: -163dBc/Hz (245.76MHz)
- Supports clock frequencies up to 3GHz, including clock output frequencies of 983.04MHz, 491.52MHz, 245.76MHz, and 122.88MHz
- Phase alignment mode across multiple buffers with any frequency divider setting
- Configuration through 3-wire SPI interface
- Supply voltage:
 - 3.3V core and signal I/O
 - 1.8V digital control SPI I/O (3.3V-tolerant inputs)
- Reference inputs are fail-safe
- Provides four output channels with a total of 16 differential outputs
- Outputs channels include:
 - Dedicated clock outputs
 - Outputs configurable as SYSREF outputs with individual phase delay stages, or configurable as additional clock outputs
 - Clock outputs are powered-on/enabled at startup
 - QREF_r (SYSREF) outputs disabled at startup
- Each clock channel contains:
 - Frequency Dividers: ÷1, ÷2, ÷3, ÷4, ÷6, ÷8, ÷12, ÷16, ÷24
 - Clock phase delay circuits, delay unit is the clock period; 256 steps
- SYSREF: Configurable precision phase delay circuits: 8 steps of 131ps, 262ps, 393ps, or 524ps
- Flexible differential outputs:
 - LVDS/LVPECL/AC-HCSL
 - Amplitude configurable for LVDS and LVPECL
 - Power-down modes for unused outputs
 - Supports DC and AC coupling
 - QREF_r (SYSREF) output pre-bias feature to prevent glitches when turning output on or off
- Package: 64-VFQFPN (9.0 × 9.0 × 0.85 mm)
- Ambient temperature range: -40°C to +105°C (case)

Contents

1.	Block Diagram	3
2.	Pin Information	4
2.1	Pin Assignments	4
2.2	Pin Descriptions	5
3.	Specifications	7
3.1	Absolute Maximum Ratings	7
3.2	Recommended Operating Conditions	7
3.3	Thermal Specifications	7
3.4	Pin Characteristics	8
3.5	DC Characteristics	8
3.6	AC Characteristics	10
3.6.1	Additive Clock Phase Noise Characteristics	12
4.	Principles of Operation	17
4.1	Overview	17
4.2	Signal Flow	17
4.3	Clock Channel Divider	17
4.4	Phase Delay	18
4.4.1	Delay Calibration Block (DCB)	18
4.5	QCLK _y to SYSREF Phase Alignment	20
4.5.1	QCLK _y and QREF _r Phase Alignment Across Multiple Devices	20
4.6	Differential Outputs	22
4.7	Device Startup, Reset, and Synchronization	23
4.7.1	Changing Frequency Dividers and Phase Delay Values	24
4.8	SPI Interface	25
5.	Application Information	28
5.1	Fail-safe Inputs	28
5.2	Input Interface Circuits	28
5.3	Termination for QCLK _y , QREF _r LVDS Outputs	28
5.4	AC Termination for QCLK _y , QREF _r LVDS Outputs	29
5.5	Termination for QCLK _y , QREF _r LVPECL Outputs	30
5.6	Termination for QCLK _y , QREF _r AC-HCSL Outputs	30
5.7	AC Termination for QCLK _y , QREF _r AC-HCSL Outputs	30
5.8	Package Exposed Pad Thermal Release Path	31
5.8.1	Case Temperature Considerations	31
5.8.2	Example Calculation for Junction Temperature	32
6.	Registers	33
6.1	Register Descriptions	33
6.2	Channel and Clock Output Registers	35
6.3	QREF _r Output State Registers	37
6.4	SYSREF, DCB, and Phase Alignment Control Registers	39
6.5	General Control Registers	40
7.	Package Outline Drawings	41
8.	Marking Diagram	41
9.	Ordering Information	42
10.	Glossary	42
11.	Revision History	42

1. Block Diagram

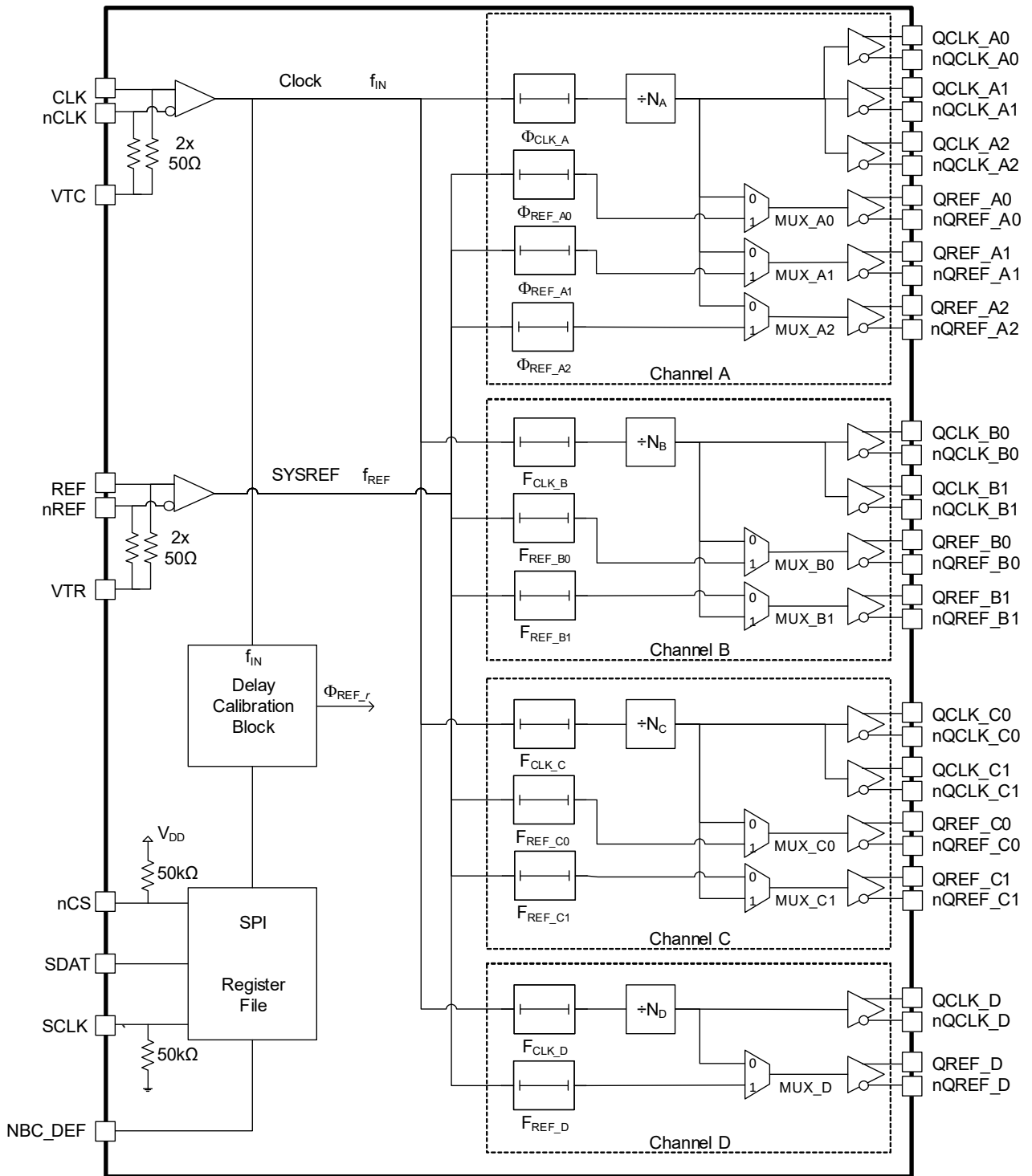

Figure 1. Block Diagram

2. Pin Information

2.1 Pin Assignments

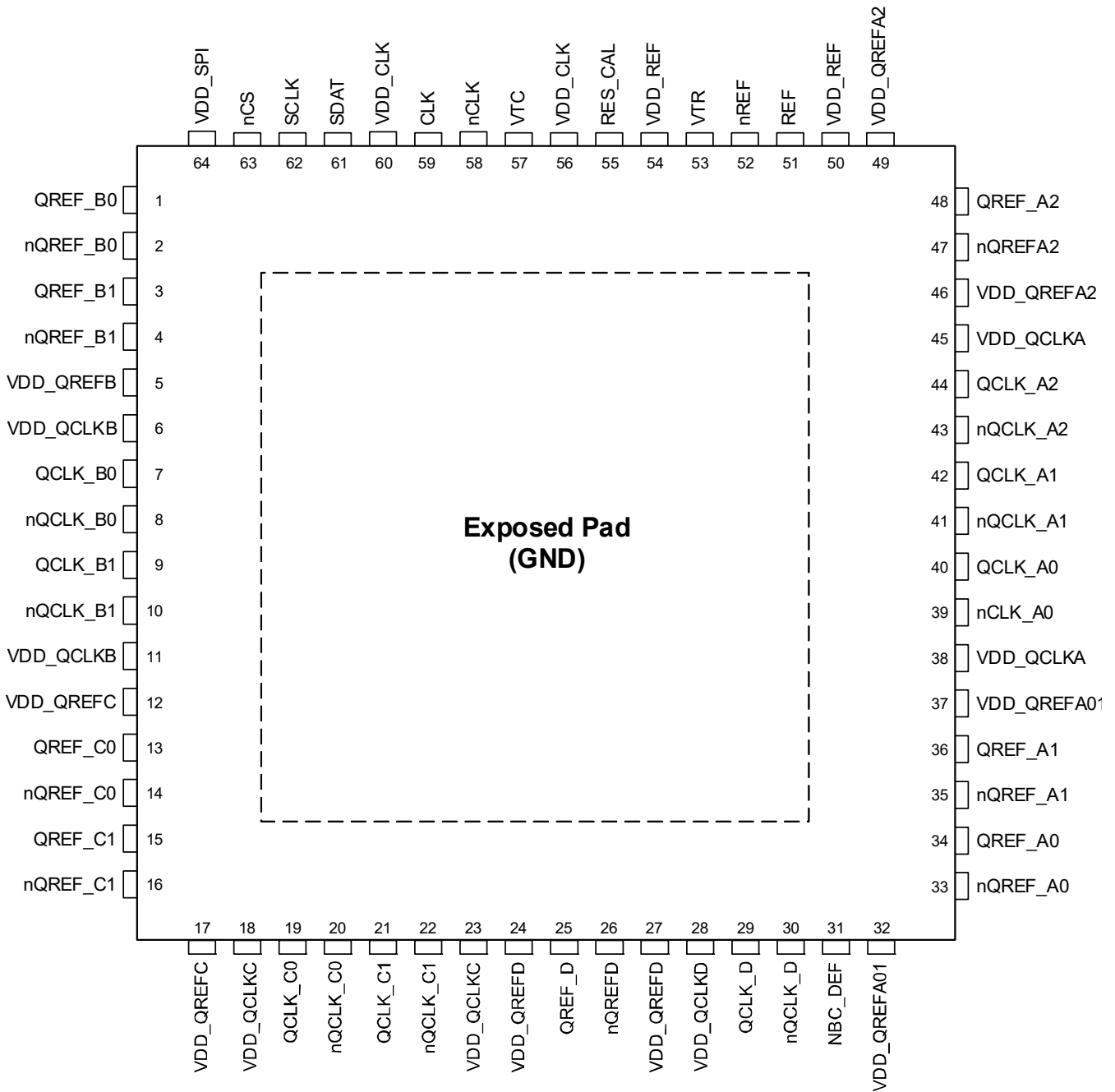

Figure 2. Pin Assignments, 64-VFQFPN Package (Top View)

2.2 Pin Descriptions

Table 1. Pin Descriptions

Pin Number	Pin Name	Type ¹⁾	Description
1, 2	QREF_B0, nQREF_B0	Output	Differential SYSREF/clock output QREF_B0. LVDS style for SYSREF operation, configurable LVPECL/LVDS/AC-HCSL style and amplitude for clock operation.
3, 4	QREF_B1, nQREF_B1	Output	Differential SYSREF/clock output QREF_B1. LVDS style for SYSREF operation, configurable LVPECL/LVDS/AC-HCSL style and amplitude for clock operation.
5	V _{DD_QREFB}	Power	Positive supply voltage (3.3V) for the QREF_B[1:0] outputs.
6	V _{DD_QCLKB}	Power	Positive supply voltage (3.3V) for the QCLK_B[1:0] outputs.
7, 8	QCLK_B0, nQCLK_B0	Output	Differential clock output QCLK_B0. Configurable LVPECL/LVDS/AC-HCSL style and amplitude.
9, 10	QCLK_B1, nQCLK_B1	Output	Differential clock output QCLK_B1. Configurable LVPECL/LVDS/AC-HCSL style and amplitude.
11	V _{DD_QCLKB}	Power	Positive supply voltage (3.3V) for the QCLK_B[1:0] outputs.
12	V _{DD_QREFC}	Power	Positive supply voltage (3.3V) for the QREF_C[1:0] outputs.
13, 14	QREF_C0, nQREF_C0	Output	Differential SYSREF/clock output QREF_C0. LVDS style for SYSREF operation, configurable LVPECL/LVDS/AC-HCSL style and amplitude for clock operation.
15, 16	QREF_C1, nQREF_C1	Output	Differential SYSREF/clock output QREF_C1. LVDS style for SYSREF operation, configurable LVPECL/LVDS/AC-HCSL style and amplitude for clock operation.
17	V _{DD_QREFC}	Power	Positive supply voltage (3.3V) for the QREF_C[1:0] outputs.
18	V _{DD_QCLKC}	Power	Positive supply voltage (3.3V) for the QCLK_C[1:0] outputs.
19, 20	QCLK_C0, nQCLK_C0	Output	Differential clock output QCLK_C0. Configurable LVPECL/LVDS/AC-HCSL style and amplitude.
21, 22	QCLK_C1, nQCLK_C1	Output	Differential clock output QCLK_C1. Configurable LVPECL/LVDS/AC-HCSL style and amplitude.
23	V _{DD_QCLKC}	Power	Positive supply voltage (3.3V) for the QCLK_C[1:0] outputs.
24	V _{DD_QREFD}	Power	Positive supply voltage (3.3V) for the QREF_D outputs.
25, 26	QREF_D, nQREF_D	Output	Differential SYSREF/clock output QREF_D. LVDS style for SYSREF operation, configurable LVPECL/LVDS/AC-HCSL style and amplitude for clock operation.
27	V _{DD_QREFD}	Power	Positive supply voltage (3.3V) for the QREF_D outputs.
28	V _{DD_QCLKD}	Power	Positive supply voltage (3.3V) for the QCLK_D outputs.
29, 30	QCLK_D, nQCLK_D	Output	Differential clock output QCLK_D. Configurable LVPECL/LVDS/AC-HCSL style and amplitude.
31	NBC_DEF	Input (PU)	Sets the default (power-up) value of the least significant bit of the NB and NC frequency dividers. Fail-safe input.
32	V _{DD_QREFA01}	Power	Positive supply voltage (3.3V) for the QREF_A[1:0] outputs.
33, 34	nQREF_A0, QREF_A0	Output	Differential SYSREF/clock output QREF_A0. LVDS style for SYSREF operation, configurable LVPECL/LVDS/AC-HCSL style and amplitude for clock operation.
35, 36	nQREF_A1, QREF_A1	Output	Differential SYSREF/clock output QREF_A1. LVDS style for SYSREF operation, configurable LVPECL/LVDS/AC-HCSL style and amplitude for clock operation.
37	V _{DD_QREFA01}	Power	Positive supply voltage (3.3V) for the QREF_A[1:0] outputs.
38	V _{DD_QCLKA}	Power	Positive supply voltage (3.3V) for the QCLK_A[2:0] outputs.
39, 40	nQCLK_A0, QCLK_A0	Output	Differential clock output QCLK_A0. Configurable LVPECL/LVDS/AC-HCSL style and amplitude.
41, 42	nQCLK_A1, QCLK_A1	Output	Differential clock output QCLK_A1. Configurable LVPECL/LVDS/AC-HCSL style and amplitude.
43, 44	nQCLK_A2, QCLK_A2	Output	Differential clock output QCLK_A2. Configurable LVPECL/LVDS/AC-HCSL style and amplitude.
45	V _{DD_QCLKA}	Power	Positive supply voltage (3.3V) for the QCLK_A[2:0] outputs.
46	V _{DD_QREFA2}	Power	Positive supply voltage (3.3V) for the QREF_A2 output.

Table 1. Pin Descriptions (Cont.)

Pin Number	Pin Name	Type ¹⁾	Description
47, 48	nQREF_A2, QREF_A2	Output	Differential SYSREF/clock output QREF_A2. LVDS style for SYSREF operation, configurable LVPECL/LVDS/AC-HCSL style and amplitude for clock operation.
49	V _{DD_QREFA2}	Power	Positive supply voltage (3.3V) for the QREF_A2 output.
50	V _{DD_REF}	Power	Positive supply voltage (3.3V) for the differential SYSREF input REF, nREF.
51, 52	REF, nREF	Input	SYSREF inverting and non-inverting differential input. Compatible with LVPECL and LVDS signals. REF and nREF are internally 50Ω terminated to the VTR pin. Fail-safe input.
53	VTR	-	Internal termination for the differential clock input REF, nREF. Both REF and nREF inputs are internally terminated 50Ω to this pin. See input termination information in Application Information . Fail-safe input.
54	V _{DD_REF}	Power	Positive supply voltage (3.3V) for the differential SYSREF input REF, nREF
55	RES_CAL	Analog	Connect a 2.8 kΩ (1%) resistor to GND for output current calibration.
56	V _{DD_CLK}	Power	Positive supply voltage (3.3V) for the differential device clock input CLK, nCLK.
57	VTC	-	Internal termination for the differential clock input CLK, nCLK. Both CLK and nCLK inputs are internally 50Ω terminated to the VTR pin. See input termination information in Application Information . Fail-safe input.
58, 59	nCLK, CLK	Input	Device clock inverting and non-inverting differential clock input. Compatible with LVPECL and LVDS signals. CLK and nCLK are internally terminated to VTC through 50Ω. Fail-safe input.
60	V _{DD_CLK}	Power	Positive supply voltage (3.3V) for the differential device clock input CLK, nCLK.
61	SDAT	Input/ Output	Serial Control Port SPI Mode Data Input and Output. 1.8V LVCMOS/LVTTL interface levels. 3.3V tolerant when input.
62	SCLK	Input (PD)	Serial Control Port SPI Mode Clock Input. 1.8V LVCMOS/LVTTL interface levels. 3.3V-tolerant when input.
63	nCS	Input (PU)	Serial Control Port SPI Chip Select Input. 1.8V LVCMOS/LVTTL interface levels and 3.3V tolerant.
64	V _{DD_SPI}	Power	Positive supply voltage (3.3V) for the SPI interface.
Exposed Pad (EP)	GND	Power	Ground supply voltage (GND) and ground return path. Connect to board GND (0V).

1. Internal pull-up (PU) and pull-down (PD) resistors are indicated in parentheses. See [Table 5](#) for values.

3. Specifications

3.1 Absolute Maximum Ratings

Caution: Do not operate at or near the maximum ratings listed for extended periods of time. Exposure to such conditions can adversely impact product reliability and result in failures not covered by warranty.

Table 2. Absolute Maximum Ratings

Item	Minimum	Maximum	Unit
Supply Voltage, V_{DD_V}	-	3.6	V
Inputs	-0.5 to V_{DD_V}	$V_{DD_V} + 0.5$	V
Outputs, V_O (LVCMOS)	-0.5 to V_{DD_V}	$V_{DD_V} + 0.5$	V
Outputs, I_O (LVPECL) Continuous Current Surge Current	- -	50 100	mA
Outputs, I_O (LVDS) Continuous Current Surge Current	- -	50 100	mA
Outputs, I_O (AC-HCSL) Continuous Current Surge Current	- -	50 100	mA
Input Termination Current, I_{VT}	-35	35	mA
Junction Temperature, T_J	-	150	°C
Storage Temperature, T_{STG}	-65	150	°C
ESD – Human Body Model [1]	-	2000	V
ESD – Charged Device Model [1]	-	500	V

1. According to JEDEC JS-001-2012/JESD22-C101.

3.2 Recommended Operating Conditions

Table 3. Recommended Operating Conditions

Item	Minimum	Maximum	Unit
Supply Voltage, V_{DD_V}	-	3.3	V
Operating Junction Temperature, T_J [1]	-	125	°C
Board Temperature, T_B	-	105	°C

1. 125°C/10year lifetime is based on the evaluation of intrinsic wafer process technology reliability metrics. The limiting wafer level reliability factor for this technology with respect to high temperature operation is electro-migration. The device is verified to the maximum operating junction temperature through simulation.

3.3 Thermal Specifications

Table 4. Thermal Resistance for 64-VFQFPN Package [1]

Symbol	Thermal Parameter	Condition	Value	Unit
Θ_{JA}	Junction to ambient	0 m/s air flow	22.76	°C/W
		1 m/s air flow	19.25	°C/W
		2 m/s air flow	17.70	°C/W
		3 m/s air flow	16.87	°C/W
		4 m/s air flow	16.37	°C/W
		5 m/s air flow	16.03	°C/W

Table 4. Thermal Resistance for 64-VFQFPN Package [1] (Cont.)

Symbol	Thermal Parameter	Condition	Value	Unit
θ_{JC}	Junction to case	-	14.33	°C/W
θ_{JB}	Junction to board	-	1.1	°C/W

1. Standard JEDEC 2S2P multilayer PCB.

3.4 Pin Characteristics

Table 5. Pin Characteristics, $V_{DD_V} = 3.3V \pm 5\%$, $T_A = -40^\circ C$ to $+105^\circ C$

Symbol	Parameter	Test Conditions	Minimum	Typical	Maximum	Unit
C_{IN}	Input Capacitance	-	-	2	4	pF
R_{PD}	Input Pull-Down Resistor	SCLK	-	51	-	kΩ
R_{PU}	Input Pull-Up Resistor	nCS	-	51	-	kΩ
R_{OUT}	LVC MOS Output Impedance	SDAT (when output)	-	25	-	Ω

3.5 DC Characteristics

Table 6. Power Supply DC Characteristics, $V_{DD_V} = 3.3V \pm 5\%$, $T_A = -40^\circ C$ to $+105^\circ C$ [1]

Symbol	Parameter	Test Conditions	Minimum	Typical	Maximum	Unit
V_{DD_V}	Core Supply Voltage	-	3.135	3.3	3.465	V
I_{DD} (Total)	Power Supply Current	QCLK_y and QREF_r set to LVDS, 750mV amplitude, terminated 100Ω, Nx dividers set to +1	-	820	960	mA

1. Electrical parameters are confirmed over the specified ambient operating temperature range, which is established when the device is mounted in a test socket with maintained transverse airflow greater than 500 lpm. The device will meet specifications after thermal equilibrium has been reached under these conditions.

Table 7. Typical Power Supply Current Characteristics, $V_{DD_V} = 3.3V$, $T_A = 25^\circ C$ [1][2]

Symbol	Supply Pin Current		Test Case							Unit
			1	2	3	4	5	6	7	
-	QCLK_y	Style	LVPECL	LVPECL	LVDS	AC-HCSL	LVDS	LVDS	LVDS	-
		State	On	On	On	On	On	On	On	-
		Amplitude	350	750	350	500	350	750	750	mV
-	QREF_r	Style	LVDS	LVDS	LVDS	LVDS	LVDS	LVDS	LVDS	-
		State	Off	Off	Off	Off	On	On	On	-
		Amplitude	-	-	-	-	350	350	750	mV
I_{DD_SRC}	Current through the V_{DD_SPI} , V_{DD_REF} , V_{DD_CLK} pins		137	137	190	191	192	190	189	mA
I_{DD_CLKA}	Current through the V_{DD_QCLKA} pins		35	42	84	144	84	109	109	mA
I_{DD_CLKBCD}	Current through the V_{DD_QCLKB} , V_{DD_QCLKC} , V_{DD_QCLKD} pins		103	115	114	276	176	216	214	mA
I_{DD_REFA}	Current through the $V_{DD_QREFA01}$, V_{DD_QREFA2} pins		4	4	9	9	72	67	98	mA
I_{DD_REFBCD}	Current through the V_{DD_QREFB} , V_{DD_QREFC} , V_{DD_QREFD} pins		7	7	15	15	120	111	164	mA

1. f_{IN} (input) = 491.52MHz, $f_{SYSREF} = 7.68MHz$, $NA = 0x0000$ (≠1), $NB = 0x0011$ (≠4).
 2. QCLK_y and QREF_r outputs unloaded.

Table 8. LVCMOS DC Characteristics, $V_{DD_V} = 3.3V \pm 5\%$, $T_A = -40^\circ C$ to $+105^\circ C$ [1]

Symbol	Parameter		Test Conditions	Minimum	Typical	Maximum	Unit
V_{IH}	Input High Voltage	NBC_DEF	-	2.0	-	V_{DD_V}	V
V_{IL}	Input Low Voltage		-	-0.3	-	0.8	V
I_{IH}	Input High Current	NBC_DEF	$V_{DD_V} = 3.3V, V_{IN} = 3.3V$	-	-	5	μA
I_{IL}	Input Low Current		$V_{DD_V} = 3.3V, V_{IN} = 0V$	-150	-	-	μA

1. Electrical parameters are confirmed over the specified ambient operating temperature range, which is established when the device is mounted in a test socket with maintained transverse airflow greater than 500 lfm. The device will meet specifications after thermal equilibrium has been reached under these conditions.

Table 9. LVCMOS (JESD8-7A, 1.8V) DC Characteristics, $V_{DD_V} = 3.3V \pm 5\%$, $T_A = -40^\circ C$ to $+105^\circ C$ [1][2]

Symbol	Parameter		Test Conditions	Minimum	Typical	Maximum	Unit
V_{T+}	Positive-going input threshold voltage	SCLK, nCS, SDAT	-	0.660	-	1.365	V
V_{T-}	Negative-going input threshold voltage		-	0.495	-	1.170	V
V_H	Hysteresis Voltage		$V_{T+} - V_{T-}$	0.165	-	0.780	V
I_{IH}	Input High Current		$V_{DD_V} = 3.3V, V_{IN} = 1.8V$	-	-	150	μA
I_{IL}	Input Low Current		$V_{DD_V} = 3.465V, V_{IN} = 0V$	-150	-	-	μA
V_{OH}	Output High Voltage	SDAT (when output)	$I_{OH} = -4mA$	1.4	-	-	V
V_{OL}	Output Low Voltage		$I_{OL} = 4mA$	-	-	0.45	V

1. Electrical parameters are confirmed over the specified ambient operating temperature range, which is established when the device is mounted in a test socket with maintained transverse airflow greater than 500 lfm. The device will meet specifications after thermal equilibrium has been reached under these conditions.
2. Table is valid for the SPI interface pins nCS, SCLK and SDAT. SPI inputs have hysteresis.

Table 10. Differential Input DC Characteristics, $V_{DD_V} = 3.3V \pm 5\%$, $T_A = -40^\circ C$ to $+105^\circ C$ [1]

Symbol	Parameter		Test Conditions	Minimum	Typical	Maximum	Unit
R_{IN}	Input Resistance	CLK, nCLK REF, nREF	-	43.5	50	56.5	Ω
R_{IN_DIFF}	Differential Input Resistance	CLK, nCLK REF, nREF	-	87	100	113	Ω

1. Electrical parameters are confirmed over the specified ambient operating temperature range, which is established when the device is mounted in a test socket with maintained transverse airflow greater than 500 lfm. The device will meet specifications after thermal equilibrium has been reached under these conditions.

Table 11. LVPECL DC Characteristics $V_{DD_V} = 3.3V \pm 5\%$, $T_A = -40^\circ C$ to $+105^\circ C$ [1]

Symbol	Parameter	Test Conditions	Minimum	Typical	Maximum	Unit
V_{OH}	Output High Voltage [2]	Any Amplitude Setting	$V_{DD_V} - 1.20$	$V_{DD_V} - 0.90$	$V_{DD_V} - 0.60$	V
V_{OL}	Output Low Voltage [2]	350mV Amplitude Setting	$V_{DD_V} - 1.40$	$V_{DD_V} - 1.24$	$V_{DD_V} - 1.05$	V
		750mV Amplitude Setting	$V_{DD_V} - 1.90$	$V_{DD_V} - 1.71$	$V_{DD_V} - 1.60$	V
		1000mV Amplitude Setting	$V_{DD_V} - 2.20$	$V_{DD_V} - 1.98$	$V_{DD_V} - 1.80$	V

1. Electrical parameters are confirmed over the specified ambient operating temperature range, which is established when the device is mounted in a test socket with maintained transverse airflow greater than 500 lfm. The device will meet specifications after thermal equilibrium has been reached under these conditions.
2. Outputs terminated with 50Ω to $V_T = V_{DD_V} - 1.6V$ (350mV amplitude setting), $V_{DD_V} - 2.0V$ (750mV amplitude setting), $V_{DD_V} - 2.25V$ (1000mV amplitude setting)

Table 12. LVDS DC Characteristics $V_{DD_V} = 3.3V \pm 5\%$, $T_A = -40^\circ C$ to $+105^\circ C$ [1][2]

Symbol	Parameter	Test Conditions	Minimum	Typical	Maximum	Unit
V_{OS}	Offset Voltage [3]	350mV Amplitude Setting	1.20	1.25	1.30	V
		750mV Amplitude Setting	1.25	1.30	1.35	V
ΔV_{OS}	V_{OS} Magnitude Change	-	-	-	50	mV

1. Electrical parameters are confirmed over the specified ambient operating temperature range, which is established when the device is mounted in a test socket with maintained transverse airflow greater than 500 lfm. The device will meet specifications after thermal equilibrium has been reached under these conditions.
2. Outputs are terminated 100Ω.
3. V_{OS} changes with V_{DD_V} .

Table 13. AC-HCSL DC Characteristics $V_{DD_V} = 3.3V \pm 5\%$, $T_A = -40^\circ C$ to $+105^\circ C$ [1][2]

Symbol	Parameter	Test Conditions	Minimum	Typical	Maximum	Unit
V_{OS}	Offset Voltage	-	0.60	0.76	0.92	V

1. Electrical parameters are confirmed over the specified ambient operating temperature range, which is established when the device is mounted in a test socket with maintained transverse airflow greater than 500 lfm. The device will meet specifications after thermal equilibrium has been reached under these conditions.
2. Outputs are terminated 50Ω to ground.

3.6 AC Characteristics

Table 14. AC Characteristics, $V_{DD_V} = 3.3V \pm 5\%$, $T_A = -40^\circ C$ to $+105^\circ C$ [1]

Symbol	Parameter	Test Conditions	Minimum	Typical	Maximum	Unit	
f_{IN}	Input Frequency [2]	CLK, nCLK	Single device	0	983.04	3000	MHz
			Phase alignment between multiple devices	>0	-	1000	MHz
f_{REF}	Input Frequency	REF, nREF	SYSREF operation	0	-	100	MHz
			During multi-device phase alignment [3] N_ALIGN = +24 N_ALIGN = +48	>0 >0	-	$f_{IN} \pm 48$ $f_{IN} \pm 96$	MHz
V_{IN}	Input Voltage Amplitude[4]	CLK, nCLK REF, nREF	-	0.15	-	1.2	V
V_{DIFF_IN}	Differential Input Voltage Amplitude [4][5]	CLK, nCLK REF, nREF	-	0.3	-	2.4	V
V_{CMR}	Common Mode Input Voltage	-	1		$V_{DD_V} - (V_{IN} / 2)$	V	
f_{OUT}	Output Frequency		QCLK_y, QREF_r (Clock), N = +1 to +24	0	983.04	3000 ±N	MHz
			QREF_r (SYSREF)	0		100	MHz
odc	Output Duty Cycle [6]		QCLK_y, QREF_r (Clock), $f_{IN} \leq 2500MHz$	45	50	55	%
			QCLK_y, QREF_r (Clock), $2500MHz < f_{IN} \leq 3000MHz$	42	50	58	%
			QREF_r (SYSREF at 7.68MHz)	45	50	55	%

Table 14. AC Characteristics, $V_{DD_V} = 3.3V \pm 5\%$, $T_A = -40^{\circ}C$ to $+105^{\circ}C$ [1] (Cont.)

Symbol	Parameter	Test Conditions	Minimum	Typical	Maximum	Unit
t_R / t_F	Output Rise/Fall Time	QCLK_y, QREF_r (LVPECL), 20% to 80%	-	-	250	ps
		QCLK_y, QREF_r (LVDS), 20% to 80%	-	-	250	ps
		QCLK_y, QREF_r (AC-HCSL), 20% to 80%			250	ps
		QREF_r (SYSREF, LVDS), 20% to 80%	-	-	250	ps
$V_{O(PP)}$ [7]	LVPECL Output Voltage Swing, Peak-to-Peak, 491.52MHz	350mV Amplitude Setting	250	350	450	mV
		750mV Amplitude Setting	650	750	850	mV
		1000mV Amplitude Setting	900	1000	1100	mV
	LVPECL Differential Output Voltage Swing, Peak-to-peak, 491.52MHz	350mV Amplitude Setting	500	700	900	mV
		750mV Amplitude Setting	1300	1500	1700	mV
		1000mV Amplitude Setting	1800	2000	2200	mV
$V_{O(PP)}$ [8]	LVDS Output Voltage Swing, Peak-to-Peak, 491.52MHz	350mV Amplitude Setting	250	350	450	mV
		750mV Amplitude Setting	600	750	900	mV
	LVDS Differential Output Voltage Swing, Peak-to-Peak, 491.52MHz	350mV Amplitude Setting	500	700	900	mV
		750mV Amplitude Setting	1200	1500	1800	mV
$V_{O(PP)}$	AC-HCSL Differential Output Voltage Swing, Peak-to-Peak, 491.52MHz	-	430	480	550	mV
$t_{sk(o)}$	Output Skew [9][10], All delays set to 0	QCLK_y (same N divider) [11]	-	-	100	ps
		QCLK_y (any N divider, incident rising edge)	-	-	100	ps
		QREF_r (Clock)	-	-	100	ps
		QREF_r (SYSREF)	-	-	100	ps
		QCLK_y to QREF_r (QREF_r as clock output) [11]	-	-	200	ps
$t_{sk(pp)}$	Part-to-Part Skew All delays set to 0	CLK to any QCLK_y [11]	-	-	375	ps
		REF to any QREF_r	-	-	375	ps
t_{PD}	Propagation Delay [11] All Delay Circuits set to 0	CLK to QCLK_y [11]	250	-	750	ps
		REF to QREF_r ($\Phi_{REF_y} = 0$)	600	800	1000	ps
Δt_{PD}	Propagation Delay Variation between the Clock Input and any QCLK_y Output	CLK to QCLK_y [11]	-100	-	+100	ps
t_S	Setup Time [12]	REF to CLK (rising)	-	-	250	ps
t_H	Hold Time	CLK (rising) to REF	-	-	250	ps
-	Output Isolation between any QCLK_y-QCLK_y and QREF_r-QREF_r outputs	$f_{QCLK_y} = 983.04MHz$ [13]	60	-	-	dB
		$f_{QCLK_y} = 491.52MHz$ [13]	65	-	-	dB
		$f_{QCLK_y} = 245.76MHz$ [13]	70	-	-	dB
-	Output Isolation between any QREF_r/QCLK_y outputs	$f_{QCLK_y} = 983.04MHz, 491.52MHz, 245.76MHz; f_{QREF_r} = 7.68MHz$	50	-	-	dB

1. Electrical parameters are confirmed over the specified ambient operating temperature range, which is established when the device is mounted in a test socket with maintained transverse airflow greater than 500 lpm. The device will meet specifications after thermal equilibrium has been reached under these conditions.
2. The CLK, nCLK input supports 0Hz if the applied static signal has a minimum amplitude as specified by V_{IN} , V_{DIFF_IN} .
3. Only applicable to a multi-device phase alignment procedure as a max frequency for applying multiple edges to the REF input. This specification is not applicable if a single REF edge is used for multi-device phase alignment.
4. V_{IL} should not be less than -0.3V and V_{IH} should not be greater than V_{DD_V} .
5. Common Mode Input Voltage is defined as the cross-point voltage.

6. Input = 50% duty cycle.
7. LVPECL outputs terminated with 50Ω to $V_T = V_{DD_V} - 1.6V$ (350mV amplitude setting), $V_{DD_V} - 2.0V$ (750mV amplitude setting), $V_{DD_V} - 2.25V$ (1000mV amplitude setting).
8. LVDS outputs terminated 100Ω across Q, nQ.
9. This parameter is defined in accordance with JEDEC standard 65.
10. Defined as skew between outputs at the same supply voltage and with equal load conditions. Measured at the differential cross points.
11. All frequency dividers N are in $\pm 1, \pm 2, \pm 4$ or ± 8 ; output amplitude setting 750mV.
12. Failure to meet CLK/REF setup and hold time can result in a failure to align output phases across multiple devices.
13. Output amplitudes set to 350mV or 750mV.

Table 15. DCB and Phase Delay Characteristics, $V_{DD_V} = 3.3V \pm 5\%$, $T_A = -40^\circ C$ to $+105^\circ C$ [1]

Symbol	Parameter	Test Conditions	Minimum	Typical	Maximum	Unit	
f_{DCO}	DCO Lock Range	-	963.04	983.04	1003.04	MHz	
T_{DCB}	Φ_{REF_r} Delay Unit Range	$f_{DCO} = 983.04MHz$	DLC = 1 (DLC[1:0] = 00)	115	131	150	ps
			DLC = 2 (DLC[1:0] = 01)	230	262	300	ps
			DLC = 3 (DLC[1:0] = 10)	345	393	450	ps
			DLC = 4 (DLC[1:0] = 11)	460	524	600	ps
		$f_{DCO} = 963.04MHz$ (min DCO frequency)	DLC = 1 (DLC[1:0] = 00)	113	134	152	ps
			DLC = 2 (DLC[1:0] = 01)	226	268	304	ps
			DLC = 3 (DLC[1:0] = 10)	339	402	456	ps
			DLC = 4 (DLC[1:0] = 11)	452	536	608	ps
		$f_{DCO} = 1003.04MHz$ (max DCO frequency)	DLC = 1 (DLC[1:0] = 00)	112	128	142	ps
			DLC = 2 (DLC[1:0] = 01)	224	256	284	ps
			DLC = 3 (DLC[1:0] = 10)	336	384	426	ps
			DLC = 4 (DLC[1:0] = 11)	448	512	568	ps
T_{IN} [2]	Φ_{CLK_x} Delay Unit	$f_{IN} = 983.04MHz$	-	1017	-	ps	
f_1, f_2	DCO Phase Detector Frequency	-	-	-	200	MHz	
Δt_D	Delay unit variation	Φ_{REF_r} delay unit variation (deviation from nominal, DLC[1:0] = 00)	-	-30	0	+30	ps
		Φ_{CLK_y} delay unit variation (deviation from nominal)	-	-20	0	+20	ps

1. Electrical parameters are confirmed over the specified ambient operating temperature range, which is established when the device is mounted in a test socket with maintained transverse airflow greater than 500 lpm. The device will meet specifications after thermal equilibrium has been reached under these conditions.
2. Φ_{CLK_x} clock channel delay unit is equal to $1 \div f_{IN}$.

3.6.1 Additive Clock Phase Noise Characteristics

The RC18016 is a buffer device; it does not filter the phase noise on the input clock source. Phase noise caused by noise sources within the device can add to the input signal noise, resulting in an increased noise on the outputs (additive phase noise). Phase noise from within the part is not correlated with the noise on the input; therefore, the root-sum-square method must be used to calculate the output phase noise: $\Phi_{OUT}^2 = \Phi_{IN}^2 + \Phi_{DEVICE}^2$. As a consequence, at frequency offsets where the input phase noise Φ_{IN} is higher than internal noise sources, the effect of additive phase noise is not measurable.

Simulations of the device phase noise performance are done with an ideal input source; however, simulation models may not account for all possible internal noise sources. Table 16 shows the simulation results for the RC18016 buffers with an ideal input source. Table 17 shows output phase noise measured with a low-noise input source, with one column for the measured data and a second column which de-rates the measured data by a

factor to model the process variation. Figure 4, Figure 5, and Figure 6 show that the input phase noise is the dominating factor in the measured data up to an offset of 100kHz. Above 100kHz, the noise floor of the device dominates the characteristics.

Table 16. Additive Clock Phase Noise Characteristics (Simulation [1]), $V_{DD_V} = 3.3V \pm 5%$ [2]

Symbol	Parameter	Test Conditions	25°C	85°C, Worst Case	Unit	
$\Phi_N(1k)$	QCLK_y Phase Noise	245.76MHz	1kHz offset from Carrier	-146.2	-145.5	dBc/Hz
$\Phi_N(10k)$			10kHz offset from Carrier	-156.6	-155.3	dBc/Hz
$\Phi_N(100k)$			100kHz offset from Carrier	-161.9	-159.6	dBc/Hz
$\Phi_N(1M)$			1MHz offset from Carrier	-162.4	-160.5	dBc/Hz
$\Phi_N(10M)$			10MHz offset from Carrier and Noise Floor	-162.4	-160.5	dBc/Hz
$\Phi_N(1k)$		491.52MHz	1kHz offset from Carrier	-141.6	-141.6	dBc/Hz
$\Phi_N(10k)$			10kHz offset from Carrier	-152.7	-151.6	dBc/Hz
$\Phi_N(100k)$			100kHz offset from Carrier	-159.2	-157.0	dBc/Hz
$\Phi_N(1M)$			1MHz offset from Carrier	-159.8	-158.1	dBc/Hz
$\Phi_N(10M)$			10MHz offset from Carrier and Noise Floor	-159.9	-158.2	dBc/Hz
$\Phi_N(1k)$		983.04MHz	1kHz offset from Carrier	-134.5	-132.0	dBc/Hz
$\Phi_N(10k)$			10kHz offset from Carrier	-141.4	-141.8	dBc/Hz
$\Phi_N(100k)$			100kHz offset from Carrier	-155.8	-152.6	dBc/Hz
$\Phi_N(1M)$			1MHz offset from Carrier	-157.2	-155.3	dBc/Hz
$\Phi_N(10M)$			10MHz offset from Carrier and Noise Floor	-157.2	-155.8	dBc/Hz

1. Ideal input signal: rectangular clock signal with a slew rate of 5V/ns and without phase noise.
2. Phase noise and spurious specifications apply for device operation with QREF_r outputs inactive (no SYSREF pulses generated). Phase noise specifications are applicable for all outputs active, Nx not equal, process and voltage variations included.

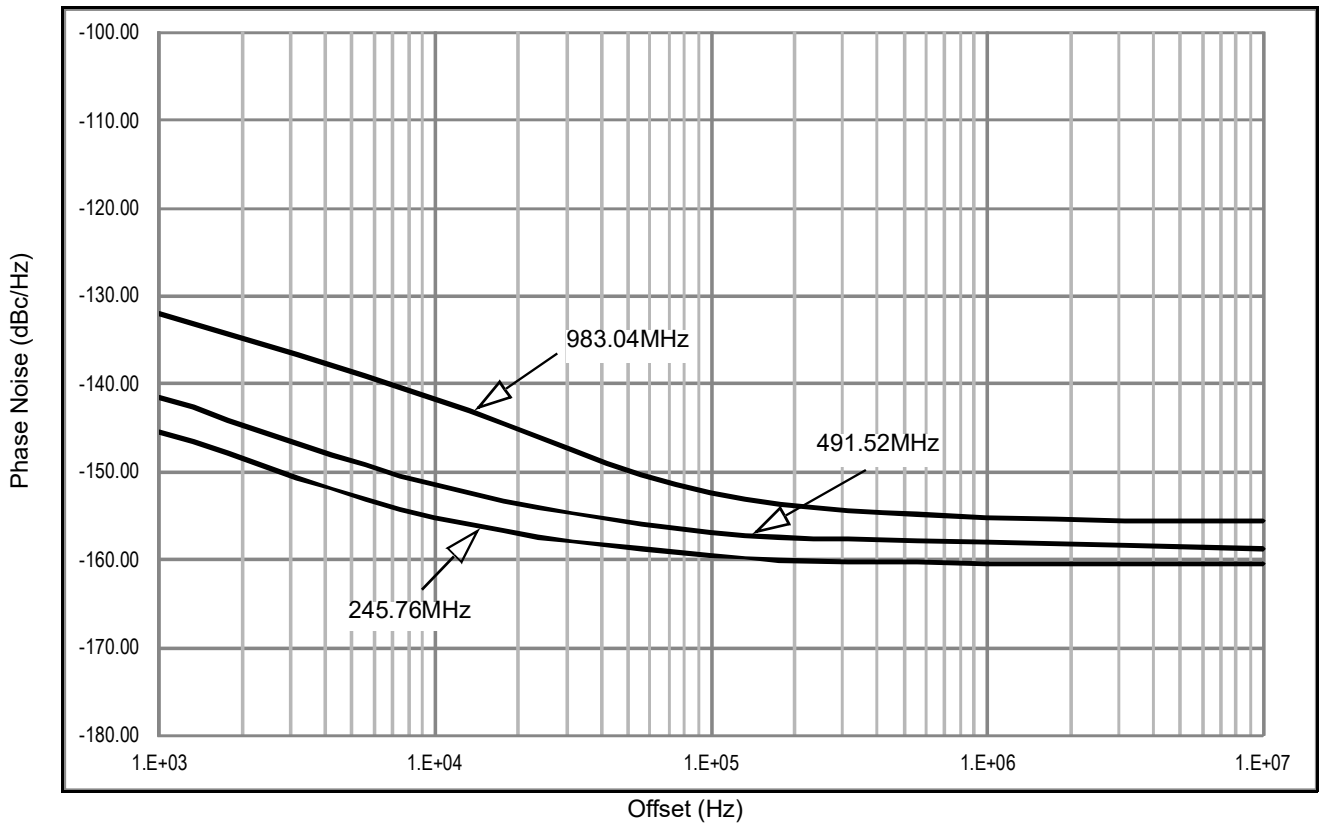

Figure 3. Additive Clock Phase Noise Characteristics (85°C, Worst Case Simulation Model)

Table 17. Additive Clock Phase Noise Characteristics (Measured), $V_{DD_V} = 3.3V \pm 5\%$, $T_A = -40^\circ C$ to $+105^\circ C$ [1][2]

Symbol	Parameter	Test Conditions	Measured [3]	De-Rated [4]	Unit	
$\Phi_N(1k)$	QCLK_y Phase Noise	245.76MHz	1kHz offset from Carrier	-141.4	-137.2	dBc/Hz
$\Phi_N(10k)$			10kHz offset from Carrier	-151.7	-149.5	dBc/Hz
$\Phi_N(100k)$			100kHz offset from Carrier	-157.8	-155.5	dBc/Hz
$\Phi_N(1M)$			1MHz offset from Carrier	-158.6	-156.2	dBc/Hz
$\Phi_N(10M)$			10MHz offset from Carrier and Noise Floor	-158.8	-156.3	dBc/Hz
$\Phi_N(1k)$		491.52MHz	1kHz offset from Carrier	-135.3	-128.4	dBc/Hz
$\Phi_N(10k)$			10kHz offset from Carrier	-145.8	-140.5	dBc/Hz
$\Phi_N(100k)$			100kHz offset from Carrier	-154.2	-149.5	dBc/Hz
$\Phi_N(1M)$			1MHz offset from Carrier	-157.2	-155.4	dBc/Hz
$\Phi_N(10M)$			10MHz offset from Carrier and Noise Floor	-157.6	-156.3	dBc/Hz
$\Phi_N(1k)$		983.04MHz	1kHz offset from Carrier	-131.3	-125.7	dBc/Hz
$\Phi_N(10k)$			10kHz offset from Carrier	-141.2	-138.5	dBc/Hz
$\Phi_N(100k)$			100kHz offset from Carrier	-149.6	-146.5	dBc/Hz
$\Phi_N(1M)$			1MHz offset from Carrier	-154.5	-152.2	dBc/Hz
$\Phi_N(10M)$			10MHz offset from Carrier and Noise Floor	-155.3	-152.5	dBc/Hz
$t_{jit}(\emptyset)$	Clock RMS Phase Jitter (Random)	Integration Range: 1kHz – 61.44MHz	-	100	fs	
		Integration Range: 12kHz – 20MHz	-	100	fs	

- Phase noise and spurious specifications apply for device operation with QREF_r outputs inactive (no SYSREF pulses generated). Phase noise specifications are applicable for all outputs active, Nx not equal.
- Electrical parameters are guaranteed over the specified ambient operating temperature range, which is established when the device is mounted in a test socket with maintained transverse airflow greater than 500 lfm. The device will meet specifications after thermal equilibrium has been reached under these conditions.
- Measured results at the maximum temperature of 85°C using an input source with a phase noise characteristics of:
 - 245.76MHz: -143.7dBc/Hz (1kHz offset), -152.5dBc/Hz (10kHz), -160.8dBc/Hz (100kHz), -172.6dBc/Hz (1MHz), -179.5dBc/Hz (10MHz).
 - 491.52MHz: -137.7dBc/Hz (1kHz offset), -147.4dBc/Hz (10kHz), -156.1dBc/Hz (100kHz), -167.6dBc/Hz (1MHz), -170.1dBc/Hz (10MHz).
 - 983.04MHz: -132.5dBc/Hz (1kHz offset), -141.4dBc/Hz (10kHz), -149.9dBc/Hz (100kHz), -161.4dBc/Hz (1MHz), -164.2dBc/Hz (10MHz).
- De-rating factor applied to the characterized data at 85°C to account for worst-case process variation.

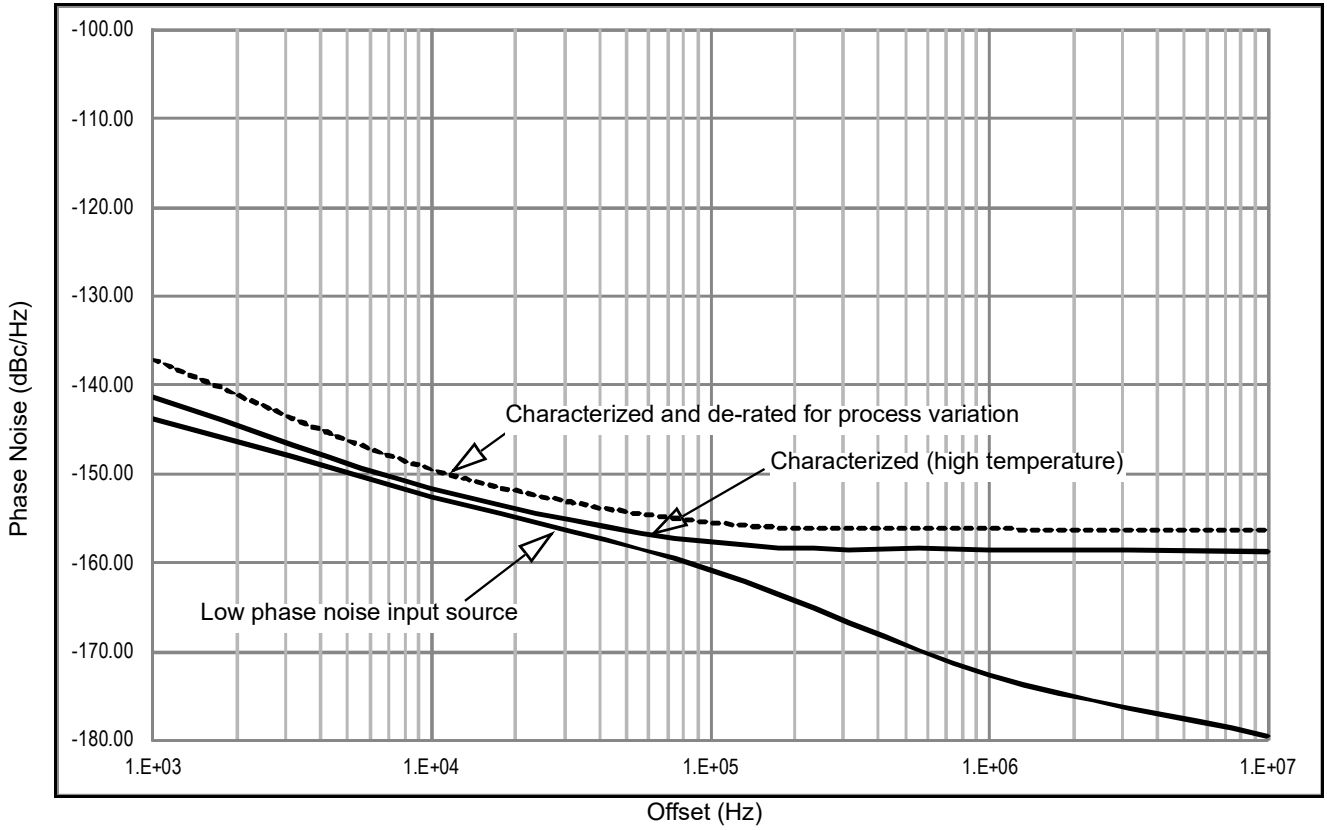

Figure 4. Additive Clock Phase Noise Characteristics (Measured), $f_{OUT} = 245.76\text{MHz}$

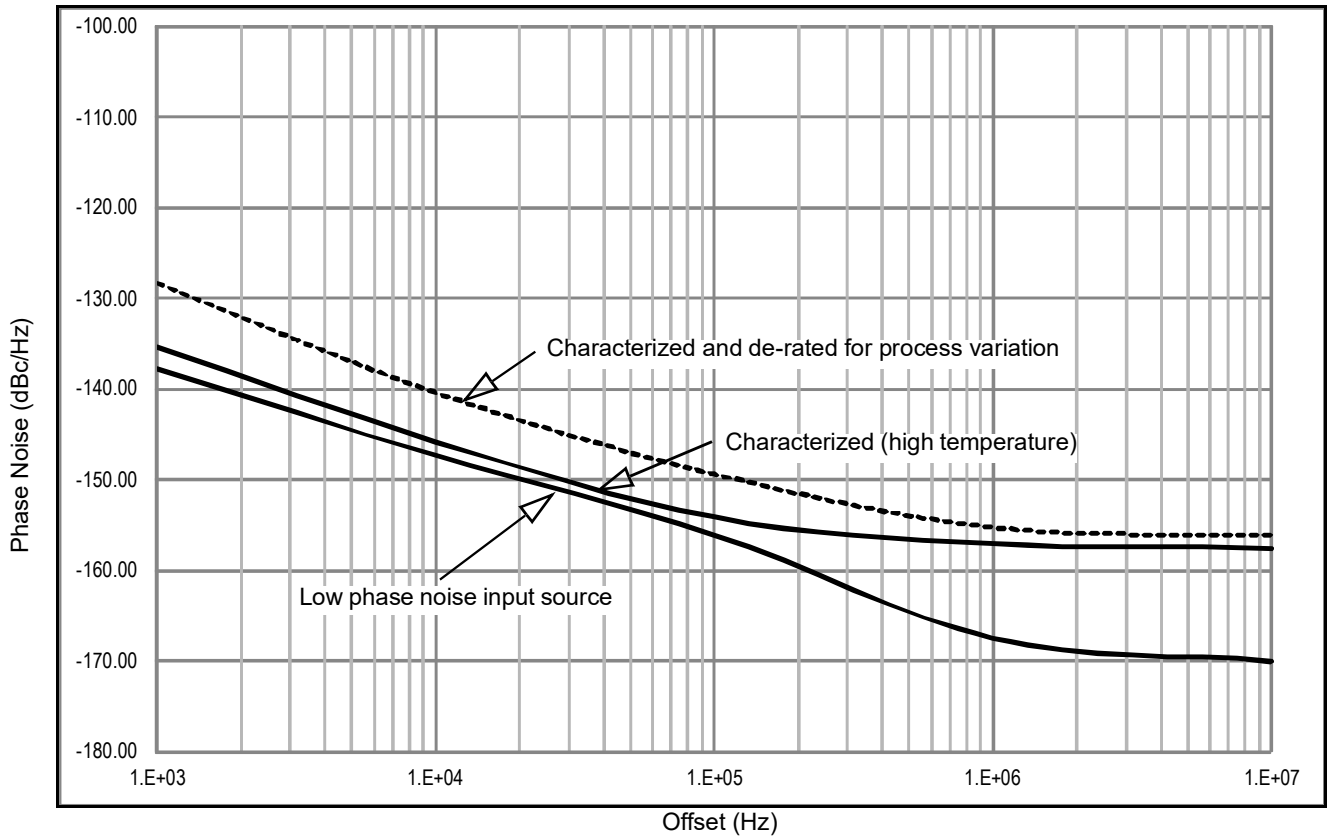

Figure 5. Additive Clock Phase Noise Characteristics (Measured), $f_{OUT} = 491.52\text{MHz}$

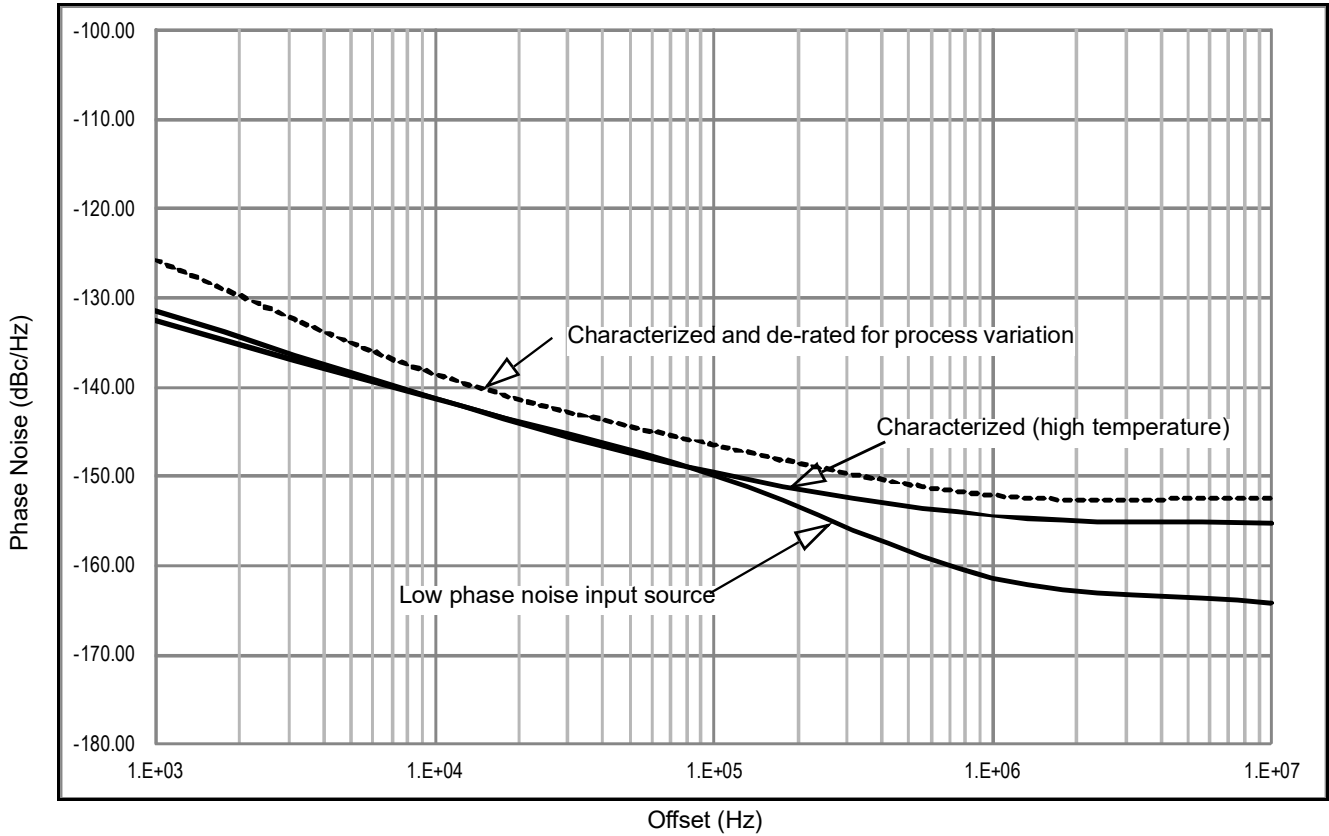

Figure 6. Additive Clock Phase Noise Characteristics (Measured), $f_{OUT} = 983.04\text{MHz}$

Table 18. SYSREF Phase Noise Characteristics (Measured)

Symbol	Parameter	Test Conditions	Typical	Units	
$\Phi_N(1\text{k})$	QREF_r Phase Noise	15.36MHz [1]	1kHz offset from Carrier	-146	dBc/Hz
$\Phi_N(10\text{k})$			10kHz offset from Carrier	-152.5	dBc/Hz
$\Phi_N(100\text{k})$			100kHz offset from Carrier	-156	dBc/Hz
$\Phi_N(1\text{M})$			1MHz offset from Carrier	-156	dBc/Hz
$\Phi_N(1\text{k})$		30.72MHz [1]	1kHz offset from Carrier	-147.5	dBc/Hz
$\Phi_N(10\text{k})$			10kHz offset from Carrier	-153.5	dBc/Hz
$\Phi_N(100\text{k})$			100kHz offset from Carrier	-155.5	dBc/Hz
$\Phi_N(1\text{M})$			1MHz offset from Carrier	-155.5	dBc/Hz

1. Measured results with $\text{DLC}[1:0] = 00$ and $\text{QREF}_r = 3$.

4. Principles of Operation

4.1 Overview

The RC18016 is a JESD204B/C fanout buffer with configurable phase delay. The device supports the division, phase-delay, and distribution of high-frequency clocks (input: CLK, nCLK), and the fanout and phase-delay of low-frequency synchronization (SYSREF) signals (input: REF/nREF). Clock and SYSREF signal paths are independent and are organized in channels, with each channel consisting of several clock and SYSREF outputs. Outputs are configurable with support for LVPECL, LVDS, and AC-HCSL. Individual channels and unused circuit blocks support a powered-down state for reduced power consumption operation. The register map, accessible through a SPI interface with read-back capability, controls the main device settings.

4.2 Signal Flow

The RC18016 offers four channels with the names A, B, C, and D. Each channel supports individual frequency-division, phase-delay and fan-out functions of the input clock to a total of eight QCLK_y clock outputs; each channel also distributes the SYSREF input signal to multiple QREF_r outputs with individual per-output phase delay capability.

The central clock distribution ensures low skew clock outputs within each channel; outputs are synchronous across channels (independent on the divider setting) on the incident rising clock edge for all outputs with equal phase delay settings.

SYSREF output are synchronous with each other for equal phase-delay settings. QCLK_y and QREF_r outputs will be phase-locked to each other if the CLK and REF inputs are phase-locked. The phase-delay capability in each signal path can be used to establish repeatable and deterministic clock to SYSREF phase relationships at the outputs.

The CLK and QREF signal paths are optimized for channel isolation allowing high-speed clocks of 983.04MHz, 1474.56MHz, or 1966.08MHz (up to 3GHz), and lower-speed SYSREF signals at, e.g., 7.68MHz or 9.6MHz, with a minimum of signal crosstalk and spurious signals.

4.3 Clock Channel Divider

Each of the independent frequency dividers N_{A-D} can be individually set to the divider values $\div 1$, $\div 2$, $\div 3$, $\div 4$, $\div 6$, $\div 8$, $\div 12$, $\div 16$, and $\div 24$. The dividers are synchronous and have an equal propagation delay on the incident edge (for the supported frequency divider settings, see [Table 19](#)). The default (power-up) divider value for channel A and D is $\div 1$, the default divider value for channel B and C are set by the state of pin 31 (NBC_DEF). See [Table 20](#).

Table 19. N_{A-D} Frequency Divider Settings

N_{A-D}	Clock Divider
0000	$\div 1$ Divider bypass and powered down
0001	$\div 2$
0010	$\div 3$
0011	$\div 4$
0100	$\div 6$
0101	$\div 8$
0110	$\div 12$
0111	$\div 16$
1000	$\div 24$

Table 20. Frequency Divider Default Settings

Divider	Default Clock Divider	
	NBC_DEF = 0	NBC_DEF = 1 [1]
N _A , N _D	÷1	
N _B , N _C	÷3	÷4

1. NBC_DEF can be left open (reads logic 1).

4.4 Phase Delay

Output phase delay is independently supported on each clock channel and each SYSREF output. The delay unit of the clock channel phase-delay circuits Φ_{CLK_x} is a function of the frequency f_{IN} applied to CLK input: $1 \div f_{IN}$.

The delay unit of the SYSREF phase-delay circuits Φ_{REF_r} is a function of an internal oscillator frequency f_{DCO} and the DLC multiplier setting. The oscillator is fully self-contained and located in delay calibration block (DCB). At startup, this oscillator is calibrated with the input frequency f_{IN} as reference. After the calibration, the oscillator is turned-off to save power and to eliminate noise. See Table 21 for details on the delay unit, number of available steps and the delay range.

Table 21. Delay Circuit Characteristics

Delay Circuit	Unit	Steps	Range
Clock channel Φ_{CLK_x}	$1 \div f_{IN}$ 1.017ns at $f_{IN} = 983.04\text{MHz}$	256	$256 \div f_{IN}$ [1] 0 to 259.3ns at $f_{IN} = 983.04\text{MHz}$
SYSREF Φ_{REF_r}	T_{DCB} [2] DLC = 0: 131ps DLC = 1: 262ps DLC = 2: 393ps DLC = 3: 524ps	8	$0 \dots 7 * T_{DCB}$ [3] DLC = 0: 0 to 0.917ns DLC = 1: 0 to 1.834ns DLC = 2: 0 to 2.751ns DLC = 3: 0 to 3.668ns

1. At $f_{IN} = 983.04\text{MHz}$, the clock channel delay range is equal to 260.416ns and encompasses 32 periods of a 122.88MHz clock signal.

2. $T_{DCB} \sim \text{DLC} \div (8 \cdot f_{DCO})$. $f_{DCO} = 983.04\text{MHz}$. DLC = 1, 2, 3 or 4.

3. SYSREF phase delay supports ≥ 8 delay stops within one input reference period for $f_{IN} = 254.76\text{MHz}$ to $f_{IN} = 983.04\text{MHz}$.

4.4.1 Delay Calibration Block (DCB)

The DCB sets the SYSREF delay unit by providing a reference signal to the QREF_r delay circuits. Figure 7 shows the functional diagram. The DCB requires configuration and calibration. Verification of the calibration is optional.

Description: The DCB consists of an internal DCO running at $f_{DCO} = 983.04 \pm 20\text{MHz}$, three frequency dividers P_{DCB} , M_{DCB} and N_{DCB} and a digital hold circuit. The DCB input frequency is the device input frequency f_{IN} at the differential CLK, nCLK input. The input frequency acts as a reference to lock the oscillator to a stable and known frequency.

The output of the DCB is the effective delay unit T_{DCB} which is approximately one eighth of the oscillator period multiplied by the DLC multiplier. The DLC multiplier extends the delay unit by a factor of 1, 2, 3 or 4. For instance, at a DCO frequency of 983.04MHz, DLC = 1 sets the SYSREF delay unit to 131ps; DLC = 2 sets the delay unit to 262ps, etc.

Configuration: Select a desired delay unit and corresponding DLC multiplier from Table 22. DLC[1:0] also sets the N_{DCB} divider. Then, find a P_{DCB} and M_{DCB} divider configuration to locate the oscillator frequency into the range of $f_{DCO} = 983.04\text{MHz}$ according to the formula in Figure 7. The DCO lock condition is $f_1 = f_2$ while both f_1 and f_2 must be lower than 200MHz. For instance, if $f_{IN} = 245.76\text{MHz}$ and the smallest possible SYSREF delay unit is desired, set DLC = 1 (DLC[1:0] = 00; also sets $N_{DCB} = \div 1$). Then, set $P_{DCB} = \div 24$ and $M_{DCB} = \div 96$. As a result,

$f_1 = f_2 = 10.24\text{MHz}$, $f_{\text{DCO}} = 983.04\text{MHz}$. This example configuration results in a delay unit of measured: 131ps. Table 23 shows more configuration examples.

Calibration: Calibration requires a valid DCB configuration with the DCO locking to an input frequency. Setting DCB_CAL = 1 starts an automatic calibration. At the end, the DCB_CAL bit will clear, the delay unit value is stored digitally and the DCO, P_{DCB} , M_{DCB} and N_{DCB} frequency dividers turn off. The QREF_r delay circuits now use the stored constant delay unit. The delay unit remains digitally stored until the next power cycle. The DCB calibration must run once as part of the device startup procedure and must be re-run after each input frequency or DCB configuration change.

Verification: Verify a successful calibration by reading the DAC_CODE value. $0 < \text{DAC_CODE} < 32767$ indicates a successful calibration. If $\text{DAC_CODE} = 0$ or $\text{DAC_CODE} = 32767$, the DCB calibration should be re-run with an alternative P_{DCB} , M_{DCB} setting while maintaining the desired $M_{\text{DCB}} \cdot N_{\text{DCB}}/P_{\text{DCB}}$ ratio for locking the DCO to the input frequency.

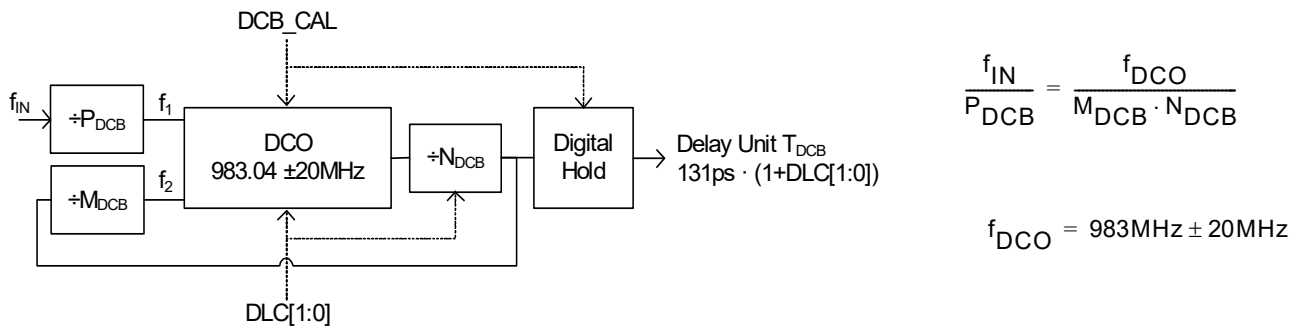

Figure 7. DCB Functional Diagram

Table 22. DCB Delay Unit at $f_{\text{DCO}} = 983.04\text{MHz}$

T_{DCB} Delay Unit (ps)	DLC		N_{DCB}
	DLC[1:0] Setting	Numeric Value	
131	00	1	1
262	01	2	2
393	10	3	3
524	11	4	4

Table 23. DCB Divider Configuration Examples [1]

f_{IN} (MHz)	T_{DCB} Delay Unit in ps	DLC	P_{DCB}	M_{DCB}
245.76	131	1	24	96
	262	2	24	48
	393	3	24	32
	524	4	24	24
491.52	131	1	48	96
	262	2	48	48
	393	3	48	32
	524	4	48	24
983.04	131	1	96	96
	262	2	96	48
	393	3	96	32
	524	4	96	24

1. $f_{\text{DCO}} = 983.04\text{MHz}$.

4.5 QCLK_y to SYSREF Phase Alignment

Single Device: To achieve an output phase alignment between the QCLK_y clock and the QREF_r SYSREF outputs, the CLK and REF input signals must be phase aligned or have a known, deterministic phase relationship. Figure 8 shows an example output phase alignment for aligned clock and SYREF inputs. The closest (smallest phase error) output alignment is achieved by setting the clock phase delay register Φ_{QCLK_y} to 0x00 (clock) and the SYSREF phase delay register Φ_{QREF_r} to 0x04. With a SYSREF phase delay setting of 0x03 or less, the QREF_r output phase is in advance of the QCLK_y phase, which is applicable in JESD204B/C application. Phase delay settings and propagation delays are independent on the clock and SYSREF frequencies. Table 24 shows recommended phase delay setting several device configurations.

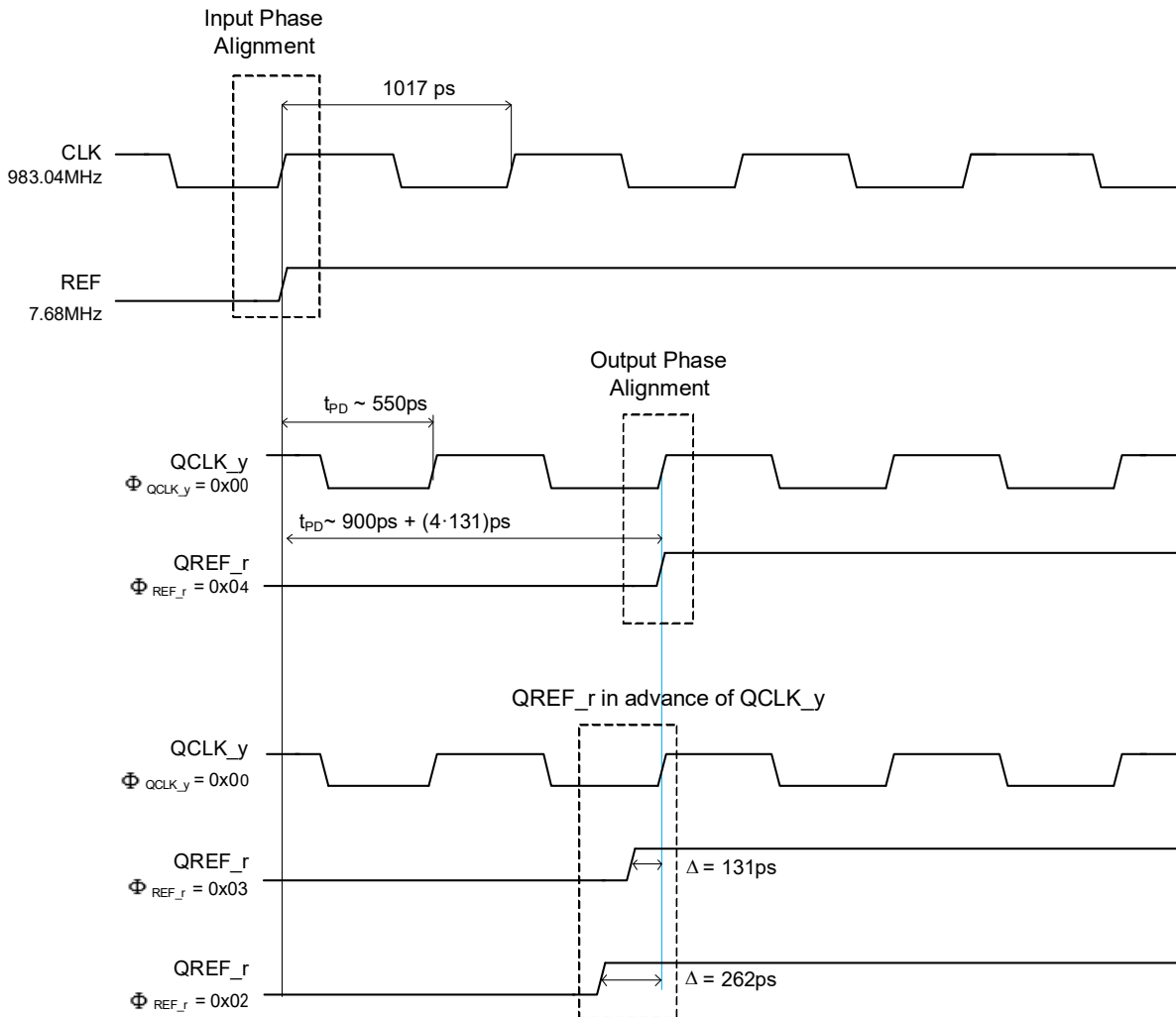

Figure 8. QCLK_y to QREF Phase Alignment

Table 24. Recommended Delay Settings for Closest Clock-SYSREF Output Phase Alignment [1]

Divider Configuration	Φ_{CLK_y}	Φ_{REF_r}
N = ÷1	0x00	0x04

1. QCLK_y and QREF outputs are aligned on the incident edge.

4.5.1 QCLK_y and QREF_r Phase Alignment Across Multiple Devices

The device architecture supports phase aligned QCLK_y and QREF_r output signals across multiple devices. For applications that use the frequency dividers of ÷2, ÷3, ÷4, ÷6, ÷8, ÷12, ÷16, or ÷24, or any combination of these

dividers, all devices participating in the output phase alignment must go through a specific alignment procedure at device startup.

Pre-conditions

- Each RC18016 must be driven by a clock device that keeps clock and SYSREF signals aligned at the CLK and REF inputs (see setup and hold time specification).
- The frequency on the REF input must be smaller than any QCLK_y output frequency.
- A valid input frequency must be applied to the CLK input (e.g., 491.52MHz).

Alignment Method

- Phase alignment is achieved by driving the REF inputs with a rising edge signal at the same time with respect to the CLK input signal.
- During the alignment process, the output period of the divided clock signal (on QCLK_y outputs) will have longer periods until output alignment is achieved.
 - **Example:** Input CLK frequency is 491.52MHz, output divider is ÷4, output frequency is 122.88MHz. During the alignment procedure started by REF, the QCLK_y output period changes from 8.138ns to 10.172ns for multiple cycles. The device facilitates the period of the input signal (2.034ns) to “stretch” the output period: 8.138ns + 2.034ns = 10.172ns.

Alignment Procedure

1. Set the MD_ALIGN_Φ bit to enable the alignment procedure.
 - Wait for ≥ 5µs before applying a signal to the REF input.
2. Apply an alignment signal (rising edge) to the REF input.
 - Place the rising edge REF signal before the rising edge of the CLK signal that is shared between all participating buffers.
 - REF to CLK setup and hold time specification must be met.
 - A single REF rising edge is sufficient for starting the alignment.
3. Output behavior during alignment:
 - QCLK_y outputs in ÷1 divider mode work normally as expected without cycle slips or period increases.
 - QCLK_y outputs in ÷2, ÷3, ÷4, ÷6, ÷8, ÷12, ÷16 or ÷24 divider mode expose longer periods as described above.
 - REF outputs always buffer out the REF input signal (when QREF_r outputs are powered on and are enabled).

Result

- The procedure aligns the output phases (rising incident edge) of all QCLK_y output signals across participating buffers. This includes the output phases of the frequency-divided clock signals and the outputs divided by 1.
- The input to output delay is the same across all participating buffer devices (measured on the incident edge).
- The alignment procedure has a maximum duration of 48x (1 ÷ f_{IN}).
- After alignment is achieved, the device auto-clears the MD_ALIGN_Φ register bit.

The alignment procedure can be repeated at any time after setting the MD_ALIGN_Φ bit.

Table 25. MD_ALIGN_Φ Multi-Device Phase Alignment Function Table

MD_ALIGN_Φ	Operation	Comment
0 (default)	Multi-buffer phase alignment is disabled.	SYSREF signals at the REF input are buffered out to the SYSREF outputs when output buffers are enabled.
1	A rising edge at the REF input will start an output phase alignment procedure.	Requires a valid clock signal at the CLK input. REF to CLK setup and hold time specifications have to be met. This bit auto-clears after alignment is achieved.

4.6 Differential Outputs

Table 26. Output Features

Output	Type	Amplitude [1]	Disable	Power Down	DC Bias	Termination
QCLK_y [2], QREF_r [3] (Clock)	LVPECL	350–1000mV 3 steps	Yes	Yes	-	50Ω to V _T [4]
	LVDS	350, 750mV 2 steps			100Ω differential [5][6]	
	AC-HCSL [7]	500mV			Yes	50Ω to ground
QREF_r (SYSREF)	LVPECL	350–1000mV 3 steps	Yes	Yes	-	50Ω to V _T [4]
	LVDS	350, 750mV 2 steps			Yes [8]	100Ω differential [5][6]
	AC-HCSL [7]	500mV			Yes	50Ω to ground

- Amplitudes are measured single-ended. Differential amplitudes supported are 700mV, 1500mV and 2000mV.
- y = A0, A1, A2, B0, B1, C0, C1, D.
- r = A0, A1, A2, B0, B1, C0, C1, D.
- V_T = V_{DD_V} - 1.6V (350mV amplitude setting), V_{DD_V} - 2.0V (750mV amplitude setting), V_{DD_V} - 2.25V (1000mV amplitude setting).
- AC coupling and DC coupling supported.
- See [Application Information](#) for output termination information.
- AC-HCSL refers to an output type with voltage levels below 1.2V and AC characteristics similar to HCSL.
- In JESD204B/C applications, it is recommended to use QREF_r (SYSREF) outputs configured to LVDS and 350mV amplitude. AC-coupling and DC-coupling is supported.

Table 27. Individual Clock Output (QCLK_y) Settings [1]

PD	HSTL	STYLE	EN	A[1:0]	Output Power	Termination [2]	State	Amplitude (mV)
1	X	X	X	X	Off	100Ω differential (LVDS) or no termination	Off	X
0	0	0	0	XX	On	100Ω differential (LVDS)	Disable [3]	X
			1	00			Enable	350
					01			750
0	0	1	1	0	XX	50Ω to V _T (LVPECL)	Disable	X
				00	Enable		350	
							750	
							1000	
10	1000							
11	1000							
0	1	1	0	X	On	50Ω to ground (AC-HCSL)	Disable	X
			1	Enable			500	

- Applicable to clock outputs: QCLK_y and QREF_r outputs in clock mode (MUX_r = 0).
- See [Application Information](#) for output termination information.
- Differential output is disabled in static low state: QCLK_y = L, nQCLK_y = H.

Table 28. Individual SYSREF Output (QREF_r) Settings [1]

PD	HSTL	STYLE	EN	A[1:0]	BIAS_TYPE	Output Power	Termination [2]	State	Amplitude (mV)
1	X	X	X	X	X	Off	100Ω differential or no termination	Off	X
0	0	0	0	XX	0	On	100Ω differential (LVDS)	Disable [3]	X
			1	00	0			Enabled	350
				01	0			See Table 29	750
					1			Enabled	
0	0	1	0	XX	0	On	50Ω to V _T (LVPECL)	Disable	X
			1	00				Enable	350
				01					750
				10					1000
				11					1000
0	1	1	0	X	0	On	50Ω to ground (AC-HCSL)	Disable	X
			1	Enable				500	

1. Applicable QREF_r outputs when configured as SYSREF output (MUX_r = 1).
2. See Application Information for output termination information.
3. Differential output is disabled in static low state: QCLK_y = L, nQCLK_y = H.

Table 29. QREF_r Setting for JESD204B/C Applications

BIAS_TYPE	BIAS_r	QREF_r Outputs (LVDS)			Application
		Initial	Active Rising Edge on the REF Input	SYSREF Completed	
0	0	Static low [1]	Start switching for the number of received SYSREF pulses	Released to static low [1]	QREF_r DC coupled
	1	Static low [1]			
1	0	Static LVDS crosspoint level [2][3]	Start switching for the number of received SYSREF pulses	Released to static low [1] or static high [4], matching the final state of the REF input	QREF_r AC coupled
	1	Static LVDS crosspoint level [2][3]			

1. QREF_r = L, nQREF_r = H.
2. QREF_r = nQREF_r = VOS.
3. This is the state after setting the PD_S bit to 1 and then setting it to 0 as described in step 3 of Device Startup, Reset, and Synchronization.
4. QREF_r = H, nQREF_r = L.

4.7 Device Startup, Reset, and Synchronization

At startup, an internal POR (power-on reset) resets the RC18016 and sets all register bits to its default value. The default divider value of the NB and NC frequency dividers are set by the state of the NBC_DEF pin. After internal POR, the device will initialize internal circuits and for 2ms before it accepts an external clock signal at the CLK input (the CLK input is internally turned off during that time).

In the default configuration the QCLK_y outputs are enabled, QREF outputs are disabled at startup. Recommended configuration sequence (in order):

1. (Optional) Set the value of the CPOL register bit to define the SPI read mode so that SPI settings can be validated by subsequent SPI read accesses.
2. Verify the completion of internal power-up by reading the ST_READY status bit in register 0x6E, bit D1. ST_READY is set to 1 by the device at the end of the internal power-up procedure. Continue the device startup once ST_READY is set to 1.

3. Configure the channel circuits and the outputs to the desired values and configure the DCB:
 - For synchronization between multiple devices (see [QCLK_y and QREF_r Phase Alignment Across Multiple Devices](#)). Write a 1 to MD_ALIGN_Φ to start the multi-buffer phase alignment process. This will cause the st_any_ALIGN status bit to be set to 1, then the MD_ALIGN_Φ bit will automatically clear. The st_any_ALIGN status bit can be used to monitor the multi-buffer alignment process. When st_any_ALIGN reports 1, the device is either waiting for a rising edge on REF, or the alignment is in progress. When st_any_ALIGN reports 0, the alignment is complete. The multi-device alignment requires a valid clock signal to be applied to the CLK input.
 - Output source MUX_r, output divider N_{A-D}, clock delay Φ_{A-D}; MUX-output style, amplitude and power down mode for QCLK_y and QREF_r outputs
 - (Optional) In preparation for JESD204B/C SYSREF operation, configure the global BIAS_TYPE bit and the BIAS_r bit for each QREF_r. Further, for AC coupling applications (BIAS_TYPE = 1) after setting BIAS_TYPE to 1, set the PD_S bit to 1 and then set it to 0; this will set QREF_r and nQREF_r to the LVDS crosspoint level (VOS). If SYSREF generation is started and halted, then repeat the process of setting the PD_S bit to 1 and then setting it to 0; this will set QREF_r and nQREF_r to the LVDS crosspoint level (VOS).
 - Phase delay for Φ_{REF_r} values for the QREF_r outputs.
 - Setup the DCB settings DLC, P_{DCB} and M_{DCB} as described in the paragraph “Configuration”, see [Delay Calibration Block \(DCB\)](#)
4. If not already applied: apply a valid input frequency to CLK. Set the PB_CAL bit and the DCB_CAL bit to start the calibration of the precision bias current circuit and the DCB calibration. Both bits will auto-clear. See paragraph “Configuration” in [Delay Calibration Block \(DCB\)](#).
 - (Optional): verify the success of the DCB calibration by reading the DAC_CODE value. See paragraph “Verification” in [Delay Calibration Block \(DCB\)](#)
5. (Only for using the clock delay circuits): Set the initialization bit INIT_CLK to initiate the ΦCLK_x delay circuits. The INIT_CLK bit will self-clear. During this initialization step, all QCLK_y and QREF_r outputs are reset to the logic low state.
6. Enable or disable outputs as desired by accessing the output-enable registers 0x74 and 0x76.
7. At this point, the configuration of the registers should be completed and the SPI transfer ended. Set nCS to high level.

Registers in the address range 0x78 to 0xFF should not be used. Do not write into any registers in the 0x78 to 0xFF range.

4.7.1 Changing Frequency Dividers and Phase Delay Values

Clock Frequency Divider and Delay

The following procedure must be applied for a change of a clock divider and phase delay value N_{A-D}, and Φ_{CLKA-D}:

1. (Optional) Set the value of the CPOL register to define the SPI read mode so that SPI settings can be validated by subsequent SPI read accesses.
2. (Optional) Disable outputs that will experience a frequency divider or delay value change.
3. Configure the N_{A-D} dividers and the delay circuits Φ_{CLKA-D} to the desired new values.
4. Set the initialization bit INIT_CLK. This will initiate all divider and delay circuits, and synchronize them to each other. The INIT_CLK bit will self-clear. During this initialization step, all QCLK_y and QREF_r outputs are reset to the logic low state.
5. (Optional) Enable the outputs whose frequency divider was changed.

SYSREF Delay

The following procedure must be applied for a change of any SYSREF phase delay value Φ_{REF_r} :

1. (Optional) Set the value of the CPOL register to define the SPI read mode so that SPI settings can be validated by subsequent SPI read accesses.
2. Configure any delay circuits Φ_{REF_r} to their desired new values. During configuration of Φ_{REF_r} outputs are not stopped or interrupted.

4.8 SPI Interface

The RC18016 has a 3-wire serial control port capable of responding as a slave in an SPI configuration to allow read and write access to any of the internal registers for device programming or read back. The SPI interface consists of the SCLK (clock), SDAT (serial data input and output), and nCS (chip select) pins. A data transfer consists of any integer multiple of 8 bits and is always initiated by the SPI master on the bus. Internal register data is organized in SPI bytes of 8 bits each. If nCS is at logic high, the SDAT data I/O is in high-impedance state and the SPI interface of the RC18016 is disabled. In a write operation, data on SDAT will be clocked in on the rising edge of SCLK. In a read operation, data on SDAT will be clocked out on the falling or rising edge of SCLK depending on the CPOL setting (CPOL = 0: output data changes on the falling edge, CPOL = 1: output data changes on the rising edge).

Starting a data transfer: Requires nCS to set and hold at logic low level during the entire transfer. Setting nCS = 0 will enable the SPI interface with SDAT in data input mode. The master must initiate the first 8-bit transfer. The first bit presented to the slave is the direction bit R/nW (1 = Read, 0 = Write) and the following seven bits are the address bits A[0:6] pointing to an internal register in the address space 0 to 127. Data is presented with the LSB (least significant bit) first.

Read operation: Read from an internal register. A read operation starts with an 8-bit transfer from the master to the slave. SDAT is clocked on the rising edge of SCLK. The first bit is the direction bit R/nW which must be to 1 to indicate a read transfer, followed by 7 address bits A[0:6]. After the first 8 bits are clocked into SDAT, the SDAT I/O changes to output: the register content addressed by A[0:6] is loaded into the shift register and the next 8 SCLK falling clock cycles (if CPOL = 0) will then present the loaded register data on the SDAT output and transfer these to the master. Transfers must be completed by de-asserting nCS after any multiple 8 SCLK cycles. If nCS is de-asserted at any other number of SCLKs, the SPI behavior is undefined. SPI byte (8 bit) and back-to-back read transfers of multiple registers are supported with an address auto-increment. During multiple transfers, nCS must stay at logic low level and SDAT will present multiple registers (A), (A+1), (A+2), etc. with each 8 SCLK cycles. During SPI Read operations, the user may continue to hold nCS low and provide further bytes in a single block read.

Write operation: Write to an RC18016 register. During a write transfer, a SPI master transfers one or more bytes of data into the internal registers of the RC18016. A write transfer starts by asserting nCS to low logic level. The first bit presented by the master must set the direction bit R/nW to 0 (Write) and the 7 address bits A[0:6] must contain the 7-bit register address. Bits D0 to D7 contain 8-bit of payload data, which is written into the register addressed by A[0:6] at the end of a 8-bit write transfer. Multiple, subsequent register transfers from the master to the slave are supported by holding nCS asserted at logic low level during write transfers. The 7-bit register address will auto-increment. Transfers must be completed by de-asserting nCS after any multiple 8 SCLK cycles. If nCS is de-asserted at any other number of SCLKs, the SPI behavior is undefined.

End of transfer: After de-asserting nCS, the SPI bus is available to transfers to other slaves on the SPI bus. See also the READ diagram (Figure 9) and WRITE diagram (Figure 10) displaying the transfer of two bytes of data from and into registers.

Registers 0x78 to 0xFF: Registers in the address range 0x78 to 0xFF should not be used. Do not write into any registers in this range.

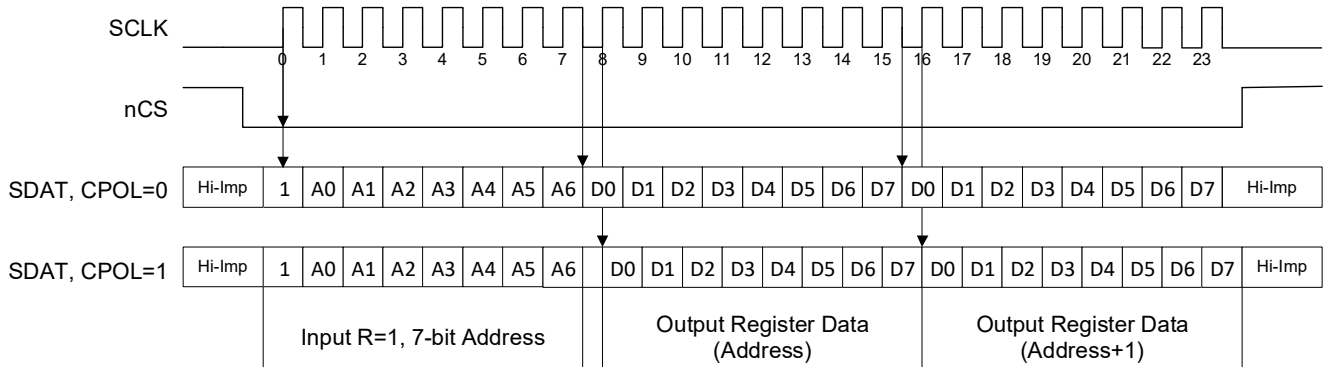

Figure 9. Logic Diagram: READ Data from RC18016 Registers for CPOL = 0 and CPOL = 1

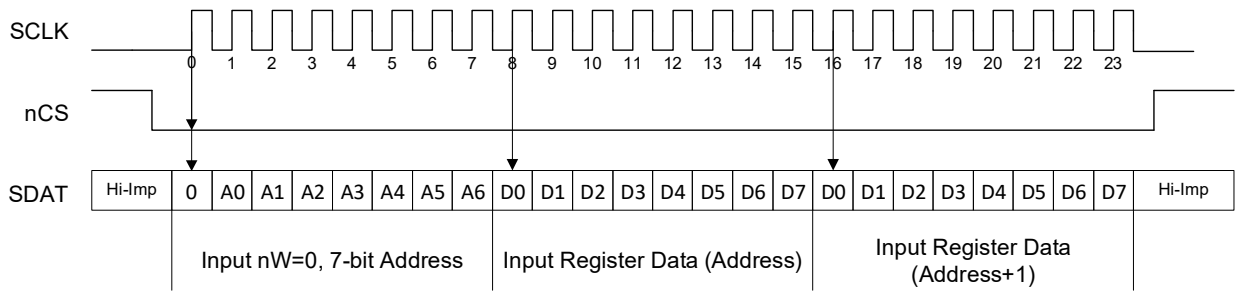

Figure 10. Logic Diagram WRITE Data into RC18016 Registers

Table 30. SPI Read / Write Cycle Timing Parameters

Symbol	Parameter	Test Condition	Minimum	Maximum	Unit
f_{SCLK}	SCLK frequency	-	-	20	MHz
t_{S1}	Setup time, nCS (falling) to SCLK (rising)	-	5	-	ns
t_{S2}	Setup time, SDAT (input) to SCLK (rising)	-	5	-	ns
t_{S3}	Setup time, nCS (rising) to SCLK (rising)	-	5	-	ns
t_{H1}	Hold time, SCLK (rising) to SDAT (input)	-	5	-	ns
t_{H2}	Hold time, SCLK (falling) to nCS (rising)	-	5	-	ns
t_{PD1F}	Propagation delay, SCLK (falling) to SDAT	CPOL = 0	-	12	ns
t_{PD1R}	Propagation delay, SCLK (rising) to SDAT	CPOL = 1	-	12	ns
t_{PD2}	Propagation delay, nCS to SDAT disable	-	-	12	ns
$t_{R, F}$	Rise, Fall Time, SPI Inputs SCLK, SDAT	-	1	10	ns

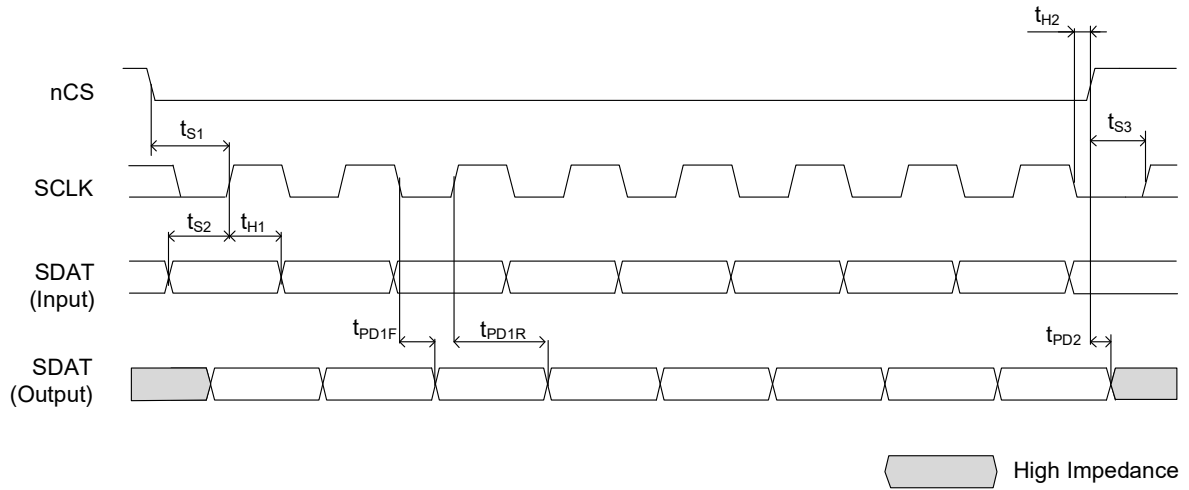

Figure 11. SPI Timing Diagram

5. Application Information

5.1 Fail-safe Inputs

The CLK/nCLK, REF/nREF, VTC, VTR, and NBC_DEF pins are fail-safe, meaning they tolerate being driven when the device is powered down.

5.2 Input Interface Circuits

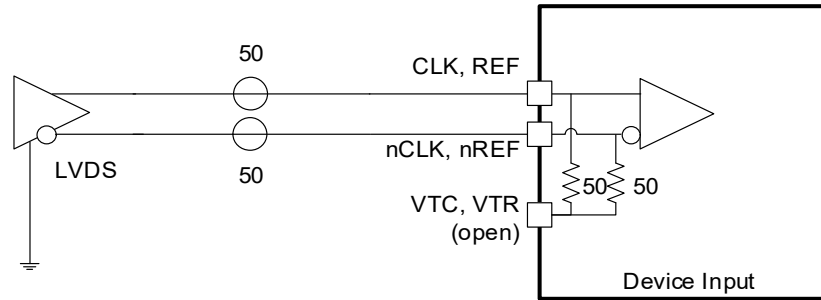

Figure 12. LVDS Output Drives RC18016 Input with Integrated Termination Resistor (DC-Coupled)

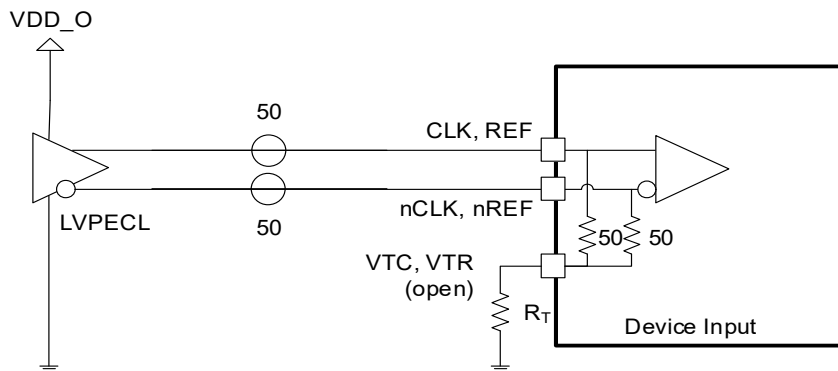

Figure 13. LVPECL Output Drives RC18016 Input with Integrated Termination Resistor (DC-Coupled)

Table 31. Termination Resistors

	V _{DD_O} = 2.5V	V _{DD_O} = 3.3V
R _T	18Ω	50Ω

5.3 Termination for QCLK_y, QREF_r LVDS Outputs

Figure 14 shows an example termination for the QCLK_y, QREF_r LVDS outputs. In this example, the characteristic transmission line impedance is 50Ω. The termination resistor R (100Ω) is matched to the line impedance. The termination resistor must be placed at the line end. No external termination resistor is required if R is an internal part of the receiver circuit. The LVDS termination in Figure 14 is applicable for any output amplitude setting specified in Table 26.

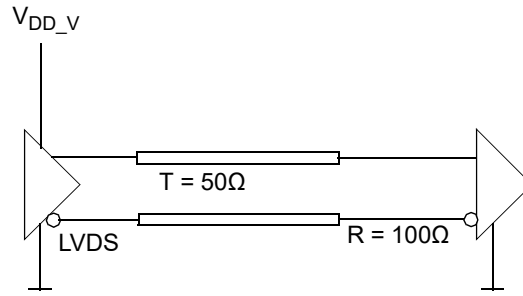

Figure 14. LVDS Output Termination

5.4 AC Termination for QCLK_y, QREF_r LVDS Outputs

Figure 15 and Figure 16 show example AC terminations for the QCLK_y, QREF_r LVDS outputs. In the examples, the characteristic transmission line impedance is 50Ω. In Figure 15, the termination resistor R (100Ω) is placed at the line end. No external termination resistor is required if R is an internal part of the receiver circuit, which is shown in Figure 16. The LVDS terminations in both Figure 15 and Figure 16 are applicable for any output amplitude setting specified in Table 26. The receiver input should be re-biased according to its common mode range specifications.

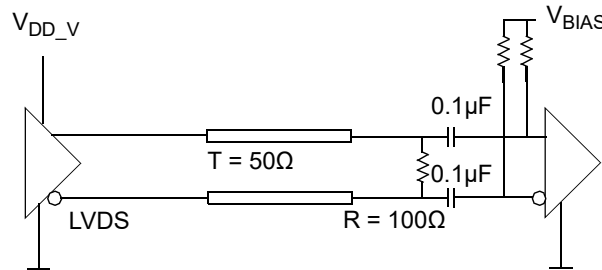

Figure 15. LVDS AC Output Termination – with Rebiased input

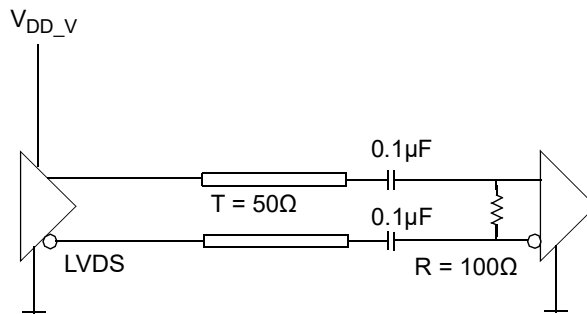

Figure 16. LVDS AC Output Termination

5.5 Termination for QCLK_y, QREF_r LVPECL Outputs

Figure 17 shows an example termination for the QCLK_y, QREF_r LVPECL outputs. In this example, the characteristic transmission line impedance is 50Ω. The R1 (50Ω) and R2 (50Ω) resistors are matched load terminations. The output is terminated to the termination voltage V_T . The V_T must be set according to the output amplitude setting defined in Table 26. The termination resistors must be placed close at the line end.

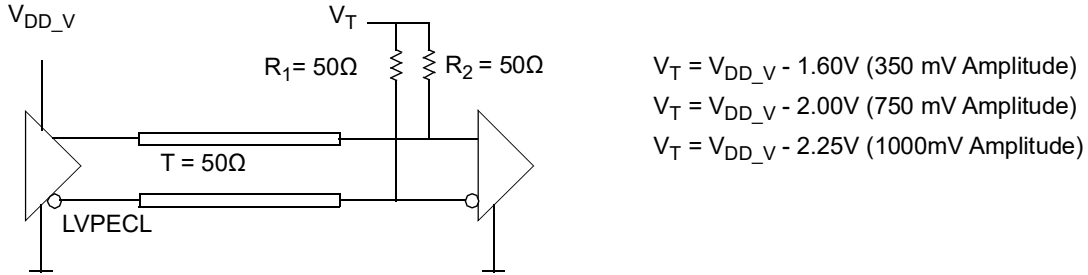

Figure 17. LVPECL Output Termination

5.6 Termination for QCLK_y, QREF_r AC-HCSL Outputs

Figure 18 shows an example termination for the QCLK_y, QREF_r AC-HCSL outputs. In this example, the transmission line is less than 10cm long and the characteristic transmission line impedance is 50Ω. The R1 (50Ω) and R2 (50Ω) resistors are matched load terminations. For transmission lines longer than 10cm, R1 (50Ω) and R2 (50Ω) should be located close to the driver.

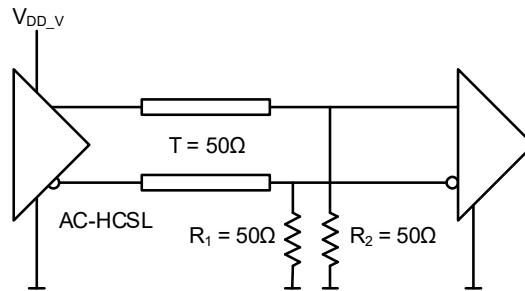

Figure 18. AC-HCSL Output Termination

5.7 AC Termination for QCLK_y, QREF_r AC-HCSL Outputs

Figure 19 shows an example AC termination for the QCLK_y, QREF_r AC-HCSL outputs. In this example, the transmission line is less than 10cm long and the characteristic transmission line impedance is 50Ω. The R1 (50Ω) and R2 (50Ω) resistors are matched load terminations. For transmission lines longer than 10cm, R1 (50Ω) and R2 (50Ω) should be located close to the driver. The receiver input should be re-biased according to its common mode range specifications.

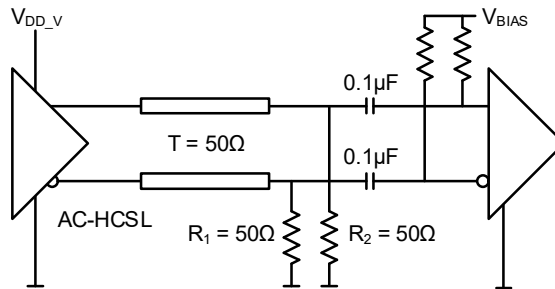

Figure 19. AC-HCSL Output Termination

5.8 Package Exposed Pad Thermal Release Path

In order to maximize both the removal of heat from the package and the electrical performance, a land pattern must be incorporated on the Printed Circuit Board (PCB) within the footprint of the package corresponding to the exposed metal pad or exposed heat slug on the package, as shown in Figure 20. The solderable area on the PCB, as defined by the solder mask, should be at least the same size/shape as the exposed pad/slug area on the package to maximize the thermal/electrical performance. Sufficient clearance should be designed on the PCB between the outer edges of the land pattern and the inner edges of pad pattern for the leads to avoid any shorts.

While the land pattern on the PCB provides a means of heat transfer and electrical grounding from the package to the board through a solder joint, thermal vias are necessary to effectively conduct from the surface of the PCB to the ground plane(s). The land pattern must be connected to ground through these vias. The vias act as “heat pipes”. The number of vias (i.e. “heat pipes”) are application specific and dependent upon the package power dissipation as well as electrical conductivity requirements. Thus, thermal and electrical analysis and/or testing are recommended to determine the minimum number needed. Maximum thermal and electrical performance is achieved when an array of vias is incorporated in the land pattern. It is recommended to use as many vias connected to ground as possible. It is also recommended that the via diameter should be 12 to 13 mils (0.30 to 0.33mm) with 1oz copper via barrel plating. This is desirable to avoid any solder wicking inside the via during the soldering process which may result in voids in solder between the exposed pad/slug and the thermal land. Precautions should be taken to eliminate any solder voids between the exposed heat slug and the land pattern.

Note: These recommendations are to be used as a guideline only. For further information, refer to the Application Note on the Surface Mount Assembly of Amkor’s Thermally/Electrically Enhance Lead-frame Base Package, Amkor Technology.

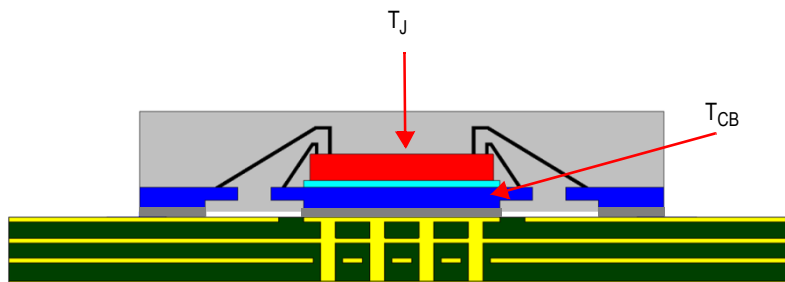

Figure 20. Assembly for Exposed Pad Thermal Release Path – Side View (Drawing not to Scale)

5.8.1 Case Temperature Considerations

The device supports applications in a natural convection environment that does not have any thermal conductivity through ambient air. The printed circuit board (PCB) is typically in a sealed enclosure without any natural or forced air flow and is kept at or below a specific temperature. The device package design incorporates an exposed pad (ePad) with enhanced thermal parameters which is soldered to the PCB where most of the heat escapes from the bottom exposed pad. For this type of application, it is recommended to use the junction-to-board thermal characterization parameter Ψ_{JB} (Psi-JB) to calculate the junction temperature (T_J) and ensure it does not exceed the maximum allowed operating junction temperature listed in [Absolute Maximum Ratings](#).

The junction-to-board thermal characterization parameter, Ψ_{JB} , is calculated using the following equation:

$T_J = T_{CB} + \Psi_{JB} \times P_D$, where:

T_J = Junction temperature at steady state condition in (°C).

T_{CB} = Case temperature (Bottom) at steady state condition in (°C).

Ψ_{JB} = Thermal characterization parameter to report the difference between junction temperature and the temperature of the board measured at the top surface of the board.

P_D = Power dissipation (W) in desired operating configuration.

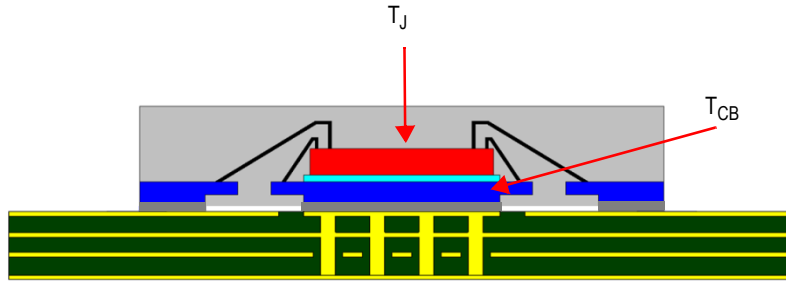

The ePad provides a low thermal resistance path for heat transfer to the PCB and represents the key pathway to transfer heat away from the IC to the PCB. It is critical that the connection of the exposed pad to the PCB is properly constructed to maintain the desired IC case temperature (T_{CB}). A good connection ensures that temperature at the exposed pad (T_{CB}) and the board temperature (T_B) are relatively the same. An improper connection can lead to increased junction temperature, increased power consumption and decreased electrical performance. In addition, there could be long-term reliability issues and increased failure rate.

5.8.2 Example Calculation for Junction Temperature

The following table is an example calculation for Junction Temperature (T_J): $T_J = T_{CB} + \Psi_{JB} \times P_D$.

Table 32. Thermal Resistance for 64-VFQFPN Package [1]

Package Type	64-VFQFPN
Body size (mm)	9.0 × 9.0 × 0.85 mm
ePad size (mm)	6.00 × 6.00 mm
Thermal Via	8 × 8 Matrix
Ψ_{JB}	1.1 C/W
T_{CB}	105°C
P_D	2.76W [2]

1. Standard JEDEC 2S2P multilayer PCB.
2. See [Table 7](#), test case 7.

For the variables above, the junction temperature is $T_J = T_{CB} + \Psi_{JB} \times P_D = 105^\circ\text{C} + 1.1^\circ\text{C/W} \times 2.76\text{W} = 108^\circ\text{C}$. Since this operating junction temperature is below the maximum operating junction temperature of 125°C, there are no long term reliability concerns. In addition, since the junction temperature at which the device was characterized using forced convection is 108.6°C, this device can function without the degradation of the specified AC or DC parameters.

6. Registers

6.1 Register Descriptions

This section contains a list of all addressable registers and a register description, sorted by function, followed for a detailed description of each bit field for each register. Several functional blocks with multiple instances in this device have individual registers controlling their settings, but since the registers have an identical format and bit meaning, they are described only once, but with an additional table to indicate their addresses and default values. All writable register fields will power up with default values as indicated in the factory "Default" column unless altered by values loaded from non-volatile storage during the initialization sequence.

Fixed read-only bits will have defaults as indicated in their specific register descriptions. Read-only status bits will reflect valid status of the conditions they are designed to monitor once the internal power-up reset has been released. Unused registers and bit positions are Reserved. Reserved bit fields will be unaffected by writes and are undefined on reads

Table 33. Configuration Registers

Register Address	Register Description
0x00-0x17	Reserved
0x18-0x1B	SYSREF, DCB and Phase Alignment Control
0x1C	Device ID
0x1D-0x1F	Reserved
0x20	Channel A, Output Divider
0x21	Channel A Delay ϕ CLK_A
0x22	Channel A PD
0x23	Reserved
0x24	Output State QCLK_A0
0x25	Output State QCLK_A1
0x26	Output State QCLK_A2
0x27	Reserved
0x28	ϕ REF_A0 Delay, MUX
0x29	ϕ REF_A1 Delay, MUX
0x2A	ϕ REF_A2 Delay, MUX
0x2B	Reserved
0x2C	Output State QREF_A0
0x2D	Output State QREF_A1
0x2E	Output State QREF_A2
0x2F	Reserved
0x30	Channel B, Output Divider
0x31	Channel B Delay ϕ CLK_B
0x32	Channel B PD
0x33	Reserved
0x34	Output State QCLK_B0
0x35	Output State QCLK_B1
0x36-0x37	Reserved
0x38	ϕ REF_B0 Delay, MUX
0x39	ϕ REF_B1 Delay, MUX
0x3A-0x3B	Reserved
0x3C	Output State QREF_B0

Table 33. Configuration Registers (Cont.)

Register Address	Register Description
0x3D	Output State QREF_B1
0x3E-0x3F	Reserved
0x40	Channel C, Output Divider
0x41	Channel C Delay Φ CLK_C
0x42	Channel C PD
0x43	Reserved
0x44	Output State QCLK_C0
0x45	Output State QCLK_C1
0x46-0x47	Reserved
0x48	Φ REF_C0 Delay, MUX
0x49	Φ REF_C1 Delay, MUX
0x4A-0x4B	Reserved
0x4C	Output State QREF_C0
0x4D	Output State QREF_C1
0x4E-0x4F	Reserved
0x50	Channel D, Output Divider
0x51	Channel D Delay Φ CLK_D
0x52	Channel D PD
0x53	Reserved
0x54	Output State QCLK_D
0x55-0x57	Reserved
0x58	Φ REF_D Delay, MUX
0x59-0x5B	Reserved
0x5C	Output State QREF_D
0x5D-0x6B	Reserved
0x6C-0x73	General Control
0x74	Output State QCLK
0x75	Reserved
0x76	Output State QREF
0x77	Reserved
0x78	Do not use
0x79	Do not use
0x7A	Do not use
0x7B	Do not use
0x7C-0x7D	Do not use
0x7E	Do not use
0x7F	Do not use
0x80-0xFF	Do not use

6.2 Channel and Clock Output Registers

The content of the channel register and clock output registers set the clock divider, output style, amplitude, power down state, enable state and the clock phase delay.

Table 34. Channel and Clock Output Register Bit Field Locations

Bit Field Location								
Register Address	D7	D6	D5	D4	D3	D2	D1	D0
0x20	Reserved	Reserved	Reserved	Reserved	N_A[3:0]			
0x30					N_B[3:0]			
0x40					N_C[3:0]			
0x50					N_D[3:0]			
0x21	ΦCLK_A[7:0]							
0x31	ΦCLK_B[7:0]							
0x41	ΦCLK_C[7:0]							
0x51	ΦCLK_D[7:0]							
0x22	PD_A	Reserved	Reserved	Reserved	Reserved	Reserved	Reserved	Reserved
0x32	PD_B							
0x42	PD_C							
0x52	PD_D							
0x24: QCLK_A0	PD_A0	Reserved	Reserved	STYLE_A0A 1	A_A0A1[1:0]		QCLKA0_A1 _HSTL	Reserved
0x25: QCLK_A1	PD_A1			Reserved	Reserved		Reserved	
0x26: QCLK_A2	PD_A2			STYLE_A2	A_A2[1:0]		QCLKA2_HS TL	
0x34: QCLK_B0	PD_B0	Reserved	Reserved	STYLE_B0B 1	A_B0B1[1:0]		QCLKB0_B1 _HSTL	Reserved
0x35: QCLK_B1	PD_B1			Reserved	Reserved		Reserved	
0x44: QCLK_C0	PD_C0	Reserved	Reserved	STYLE_C0	A_C0[1:0]		QCLK0_HST L	Reserved
0x45: QCLK_C1	PD_C1			STYLE_C1	A_C1[1:0]		QCLK1_HST L	
0x54: QCLK_D	PD_D	Reserved	Reserved	STYLE_D	A_D[1:0]		QCLKD_HS TL	
0x74	EN_QCLK_ A0	EN_QCLK_ A1	EN_QCLK_ A2	EN_QCLK_B 0	EN_QCLK_ B1	EN_QCLK_ C0	EN_QCLK_ C1	EN_QCLK_ D

Table 35. Channel and Clock Output Register Descriptions [1]

Register Description																		
Bit Field Name	Field Type	Default (Binary)	Description															
N_x[3:0]	R/W	N_A = 0000 (÷1) N_B = 001[NBC_DEF] (÷4/÷3) N_C = 001[NBC_DEF] (÷4/÷3) N_D = 0000 (÷1)	Output Frequency Divider N															
			N_x[2:0]	Frequency Divider														
			0000	÷1 (Divider bypassed and powered-down)														
			0001	÷2														
			0010	÷3														
			0011	÷4														
			0100	÷6														
			0101	÷8														
			0110	÷12														
			0111	÷16														
			1000	÷24														
			The default value of the N_B and N_C divider is set by pin 31 (NBC_DEF). See Table 20.															
PD_x	R/W	0 Value: Power up	0 = Channel x is powered up 1 = Channel x is powered down															
PD_y	R/W	0 Value: Power up	<table border="1"> <thead> <tr> <th>HSTL_y</th> <th>PD_y</th> <th>Powered State of QCLK_y</th> </tr> </thead> <tbody> <tr> <td>0</td> <td>0</td> <td>Output QCLK_y is powered up</td> </tr> <tr> <td>0</td> <td>1</td> <td>Output QCLK_y is powered down</td> </tr> <tr> <td>1</td> <td>0</td> <td rowspan="2">Output QCLK_y is powered up</td> </tr> <tr> <td>1</td> <td>1</td> </tr> </tbody> </table>		HSTL_y	PD_y	Powered State of QCLK_y	0	0	Output QCLK_y is powered up	0	1	Output QCLK_y is powered down	1	0	Output QCLK_y is powered up	1	1
HSTL_y	PD_y	Powered State of QCLK_y																
0	0	Output QCLK_y is powered up																
0	1	Output QCLK_y is powered down																
1	0	Output QCLK_y is powered up																
1	1																	
ΦCLK_x[7:0]	R/W	0000 0000 Value: 0ns	CLK_x Phase Delay															
			φCLK_x[7:0]	Phase Delay in units of the input period: φCLK_x[7:0] ÷ f _{IN} (256 steps).														
			0000 0000	0ps														
			0000 0001	1 ÷ f _{IN}														
																
			1111 1111	255 ÷ f _{IN}														
A_y[1:0]	R/W	01 Value: 750mV	QCLK_y Output Amplitude															
			Setting for HSTL = 0, STYLE = 0 (LVDS) Termination: 100Ω across	Setting for HSTL = 0, STYLE = 1 (LVPECL) Termination: 50Ω to V _T														
			A[1:0] = 00: 350mV A[1:0] = 01: 750mV A[1:0] = 10: Reserved A[1:0] = 11: Reserved	A[1:0] = 00: 350mV A[1:0] = 01: 750mV A[1:0] = 10: 1000mV A[1:0] = 11: 1000mV														
			The following control bits combine the A(mplitude) function for multiple outputs: A_A0A1 sets the output amplitude for QCLK_A0 and QCLK_A1 A_B0B1 sets the output amplitude for QCLK_B0 and QCLK_B1															
HSTL_y	R/W	0 Value: AC-HCSL disabled	HSTL_y	STYLE_y	QCLK_y Output Format.													
			0	0	Output(s) is/are LVDS (requires LVDS 100Ω output termination)													
			0	1	Output(s) is/are LVPECL (requires LVPECL 50Ω output termination to the specified recommended termination voltage)													
STYLE_y	R/W	0 Value: LVDS	1	0	Reserved													
			1	1	Output(s) is/are AC-HCSL (requires 50Ω output termination to ground)													
EN_y	-	1 Value: enabled	QCLK_y Output Enable: 0 = QCLK_y Output is disabled at the logic low state 1 = QCLK_y Output is enabled															

1. x = A, B, C, D; y = A0, A1A2, B0, B1, C0, C1, D.

6.3 QREF_r Output State Registers

The content of the QREF_r output registers selects the source signal of the QREF_r outputs, set the phase delay, the style, the amplitude, the power state, the enable state and the output bias.

Table 36. QREF_r Output State Register Bit Field Locations [1]

Bit Field Location								
Register Address	D7	D6	D5	D4	D3	D2	D1	D0
0x28: QREF_A0	Reserved	Reserved	Reserved	MUX_A0	ΦREF_A0[2:0]		Reserved	Reserved
0x29: QREF_A1				MUX_A1	ΦREF_A1[2:0]			
0x2A: QREF_A2				MUX_A2	ΦREF_A2[2:0]			
0x38: QREF_B0	Reserved	Reserved	Reserved	MUX_B0	ΦREF_B0[2:0]		Reserved	Reserved
0x39: QREF_B1				MUX_B1	ΦREF_B1[2:0]			
0x48: QREF_C0	Reserved	Reserved	Reserved	MUX_C0	ΦREF_C0[2:0]		Reserved	Reserved
0x49: QREF_C1				MUX_C1	ΦREF_C1[2:0]			
0x58: QREF_D	Reserved	Reserved	Reserved	MUX_D	ΦREF_D[2:0]		Reserved	Reserved
0x2C: QREF_A0	PD_A0	Reserved	BIAS_A0	STYLE_A0	A_A0[1:0]		QREFA0_HSTL	Reserved
0x2D: QREF_A1	PD_A1		BIAS_A1	STYLE_A1	A_A1[1:0]		QREFA1_HSTL	
0x2E: QREF_A2	PD_A2		BIAS_A2	STYLE_A2	A_A2[1:0]		QREFA2_HSTL	
0x3C: QREF_B0	PD_B0	Reserved	BIAS_B0	STYLE_B0	A_B0[1:0]		QREFB0_HSTL	Reserved
0x3D: QREF_B1	PD_B1		BIAS_B1	STYLE_B1	A_B1[1:0]		QREFB1_HSTL	
0x4C: QREF_C0	PD_C0	Reserved	BIAS_C0	STYLE_C0	A_C0[1:0]		QREFC0_HSTL	Reserved
0x4D: QREF_C1	PD_C1		BIAS_C1	STYLE_C1	A_C1[1:0]		QREFC1_HSTL	
0x5C: QREF_D	PD_D	Reserved	BIAS_D	STYLE_D	A_D[1:0]		QREFD_HSTL	Reserved
0x76	EN_QREF_A0	EN_QREF_A1	EN_QREF_A2	EN_QREF_B0	EN_QREF_B1	EN_QREF_C0	EN_QREF_C1	EN_QREF_D

1. r = A0, A1A2,, B0, B1, C0, C1, D.

Table 37. QREF_r Output State Register Descriptions [1]

Register Description							
Bit Field Name	Field Type	Default (Binary)	Description				
MUX_r	R/W	1 Value: QREF_r = SYSREF	0 = QREF_r output signal source is the channel's clock signal 1 = QREF_r output signal source is the centrally generated SYSREF signal				
ΦREF_r[2:0]	R/W	000 Value: 0ps	SYSREF Phase Delay: QREF_r delay = ΦREF_r[2:0] · T _{DCB} . Delay values for f _{DCO} = 983.04MHz. Delay values are a function of T _{DCB} .				
			ΦREF_r[2:0]	QREF_r delay in ps for a DLC[1:0] setting of:			
				00	01	10	11
			000	0	0	0	0
			001	131	262	393	524
			010	262	524	786	1048
			111	917	1834	2751	3668
BIAS_r	R/W	0	QREF_r Output Bias Voltage: Individual QREF_r output LVDS output bias operation. Not applicable to QREF_r outputs set to LVPECL mode. 0 = Normal operation 1 = Output is biased to the LVDS cross-point voltage if BIAS_TYPE (register 0x19, bit 7) is set to 1.				
			BIAS_TYPE	BIAS_r	QREF_r output operation if set to LVDS.		
			0	0	QREF_r outputs are initially logic low (QREF_r = L, nQREF_r = H) and will start switching on the first rising edge of the REF input. Use in DC-coupled applications.		
			0	1	Disabled with static low/high levels. During a SYSREF event, the output remains at static low levels (QREF_r = L, nQREF_r = H).		
			1 [2]	0	Both QREF_r and nQREF_r outputs are initially set to the LVDS crosspoint level (VOS) and will start switching on the first rising edge of the REF input. Use in AC-coupled applications.		
1 [2]	1	Output is statically set to the LVDS crosspoint voltage. During a SYSREF event, the output remains at the LVDS crosspoint level (VOS).					
A_r[1:0]	R/W	01 Value: 750mV	QREF_r Output Amplitude				
			Setting for STYLE = 0 (LVDS) Termination: 100Ω across				
			Setting for STYLE = 1 (LVPECL) Termination: 50Ω to V _T				
		A[1:0] = 00: 350mV A[1:0] = 01: 750mV A[1:0] = 10: Reserved A[1:0] = 11: Reserved	A[1:0] = 00: 350mV A[1:0] = 01: 750mV A[1:0] = 10: 1000mV A[1:0] = 11: 1000mV				
PD_r	R/W	0 Value: Powered up	QREF_r Output Power Down: 0 = Output is powered up 1 = Output is powered down. STYLE, EN and A[1:0] settings have no effect				
HSTL_r	R/W	0 Value: AC-HCSL disabled	HSTL_r	STYLE_r	QREF_x Output Format.		
			0	0	Output is LVDS (requires LVDS 100Ω output termination)		
			0	1	Output is LVPECL (requires LVPECL 50Ω output termination to the specified recommended termination voltage)		

Table 37. QREF_r Output State Register Descriptions [1] (Cont.)

Register Description					
Bit Field Name	Field Type	Default (Binary)	Description		
STYLE_r	R/W	0 Value: LVDS	1	0	Reserved
			1	1	Output is AC-HCSL (requires 50Ω output termination to ground)
EN_r	R/W	0 Value: Disabled	QREF_r Output Enable: 0 = Output is disabled at the logic low state 1 = Output is enabled		

- r = A0, A1, A2, B0, B1, C0, C1, D. x = A, B, C, D.
- For AC coupling applications (BIAS_TYPE = 1) after setting BIAS_TYPE to 1, set the PD_S bit to 1 and then set it to 0; this will set QREF_r and nQREF_r to the LVDS crosspoint level (VOS). If SYSREF generation is started and halted, then repeat the process of setting the PD_S bit to 1 and then setting it to 0; this will set QREF_r and nQREF_r to the LVDS crosspoint level (VOS).

6.4 SYSREF, DCB, and Phase Alignment Control Registers

Table 38. SYSREF, DCB and Phase Alignment Control Register Bit Field Locations

Bit Field Location								
Register Address	D7	D6	D5	D4	D3	D2	D1	D0
0x18	PD_S	Reserved	Reserved	Reserved	Reserved	Reserved	Reserved	Reserved
0x19	BIAS_TYPE	DLC[1:0]		Reserved	Reserved	Reserved	Reserved	M_DCB[8]
0x1A	M_DCB[7:0]							
0x1B	N_ALIGN	P_DCB[6:0]						

Table 39. SYSREF, DCB, and Phase Alignment Control Register Descriptions

Register Description					
Bit Field Name	Field Type	Default (Binary)	Description		
PD_S	R/W	0 Value: Powered up	SYSREF Global Power-down: 0 = SYSREF functional blocks are powered up 1 = SYSREF functional blocks are powered down		
BIAS_TYPE	R/W	0	SYSREF Output Voltage Bias: Global to all QREF_r outputs bit to control the LVDS output operation. Not applicable to QREF_r outputs set to LVPECL mode.		
			BIAS_TYPE	BIAS_r	QREF_r output operation if set to LVDS.
			0	0	QREF_r outputs are initially logic low (QREF_r = L, nQREF_r = H) and will start switching on the first rising edge of the REF input. Use in DC-coupled applications.
			0	1	Disabled with static low/high levels. During a SYSREF event, the output remains at static low levels (QREF_r = L, nQREF_r = H).
			1 [1]	0	Both QREF_r and nQREF_r outputs are initially set to the LVDS crosspoint level (VOS) and will start switching on the first rising edge of the REF input. Use in AC-coupled applications.
1 [1]	1	Output is statically set to the LVDS crosspoint voltage. During a SYSREF event, the output remains at the LVDS crosspoint level (VOS).			

Table 39. SYSREF, DCB, and Phase Alignment Control Register Descriptions (Cont.)

Register Description				
Bit Field Name	Field Type	Default (Binary)	Description	
DLC[1:0]	R/W	00 Value: 131ps	Delay Unit Multiplier: Effective delay unit for the SYSREF outputs is $(1 + \text{DLC}[1:0]) + (8 \cdot f_{\text{DCO}})$.	
			DLC[1:0]	Effective SYSREF Delay Unit for $f_{\text{DCO}} = 983.04\text{MHz}$
			00	131ps
			01	262ps
			10	393ps
			11	524ps
M_DCB[8:0]	R/W	0 0001 0000 Value: 16	Delay Calibration Block (DCB) DCO feedback divider. Set in conjunction with f_{IN} and P_DCB to achieve a DCO frequency of $983.04 \pm 20\text{MHz}$: $f_{\text{DCO}} = f_{\text{IN}} \cdot P_{\text{DCB}} \cdot M_{\text{DCB}}$.	
N_ALIGN	R/W	0 Value: +24	Frequency divider dividing the input clock signal (f_{IN}) to an internal reference for the multi-device phase alignment engine. Use +48 if any of the output clock divider is $N_x = +16$. The divider setting has an impact on the maximum frequency f_{REF} during multi-device phase alignment (see f_{REF} in AC characteristics table). 0 = +24 1 = +48	
P_DCB[6:0]	R/W	000 1000 Value: 8	Delay Calibration Block (DCB) DCO input divider. Set in conjunction with f_{IN} and M_DCB to achieve DCO frequency of $983.04 \pm 20\text{MHz}$: $f_{\text{DCO}} = f_{\text{IN}} \cdot P_{\text{DCB}} \cdot M_{\text{DCB}}$. DCO phase detector frequency should not exceed 200MHz.	

- For AC coupling applications (BIAS_TYPE = 1) after setting BIAS_TYPE to 1, set the PD_S bit to 1 and then set it to 0; this will set QREF_r and nQREF_r to the LVDS crosspoint level (VOS). If SYSREF generation is started and halted, then repeat the process of setting the PD_S bit to 1 and then setting it to 0; this will set QREF_r and nQREF_r to the LVDS crosspoint level (VOS).

6.5 General Control Registers

Table 40. General Control Register Bit Field Locations

Bit Field Location								
Register Address	D7	D6	D5	D4	D3	D2	D1	D0
0x1C	Reserved	Reserved	Reserved	DEV_ID_RC 18016	Reserved	Reserved	Reserved	Reserved
0x6C	Reserved	DAC_CODE[14:8]						
0x6D	DAC_CODE[7:0]							
0x6E	Reserved	Reserved	st_any_ALIG N	Reserved	Reserved	Reserved	ST_READY	Reserved
0x6F	Reserved	Reserved	PBIAS[5:0]					
0x70	INIT_CLK	Reserved	Reserved	Reserved	Reserved	Reserved	Reserved	Reserved
0x71	DCB_CAL	Reserved	Reserved	Reserved	Reserved	Reserved	Reserved	Reserved
0x72	PB_CAL	Reserved	Reserved	Reserved	Reserved	Reserved	Reserved	Reserved
0x73	MD_ALIGN_Φ	Reserved	Reserved	Reserved	Reserved	Reserved	Reserved	CPOL

Table 41. General Control Register Descriptions

Register Description			
Bit Field Name	Field Type	Default (Binary)	Description
DEV_ID_RC18016 [4]	R only	1	0 = Reserved 1 = RC18016
DAC_CODE[14:0]	R only	X	DAC_CODE is the result of the internal DCB calibration routine. Trigger calibration by setting the DCB_CAL bit.

Table 41. General Control Register Descriptions (Cont.)

Register Description			
Bit Field Name	Field Type	Default (Binary)	Description
st_any_ALIGN	R only	X	Multi-buffer phase alignment status. 0 = Alignment complete 1 = Awaiting a rising edge on REF, or alignment is in progress
ST_READY	R only	X	Internal startup routine completion status. The device is ready for operation when this bit is set to 1. 0 = Incomplete 1 = Completed and device is ready for operation.
PBIAS[5:0]	R only	X	BIAS level.
INIT_CLK	W only Auto-Clear	X	Clock divider and phase clock phase delay initialization. Set INIT_CLK = 1 to initialize N_x divider and Φ CLK_x clock phase delay functions. Required as part of the startup procedure and after each change of a clock divider or clock phase delay value.
PB_CAL	W only Auto-Clear	X	Precision Bias Calibration: Set PB_CAL to 1 starts the auto-calibration of an internal precision bias current source. The bias current is used as reference for outputs configured as LVDS. This bit will auto-clear after the calibration completed. Required to set as part of the startup procedure.
DCB_CAL	W only Auto-Clear	X	DCB Calibration: Setting this bit to 1 will begin the auto-calibration of the DCB. The DCB provides a reference for the SYSREF delay circuits. This bit will auto-clear. This bit should be set as part of the startup procedure. The result of the calibration routine is stored in the DAC_CODE register.
CPOL	R/W	0	SPI Read Operation SCLK Polarity: 0 = Data bits on MISO are output at the falling edge of SCLK edge. 1 = Data bits on MISO are output at the rising edge of SCLK edge.
MD_ALIGN_Φ	R/W Auto-clear	0	Multi-Buffer Phase Alignment Start Writing 1 to this bit will start the multi-buffer phase alignment process and cause the st_any_ALIGN bit to be set to 1. This bit will auto-clear.

7. Package Outline Drawings

The package outline drawings are located at the end of this document and are accessible from the Renesas website. The package information is the most current data available and is subject to change without revision of this document.

8. Marking Diagram

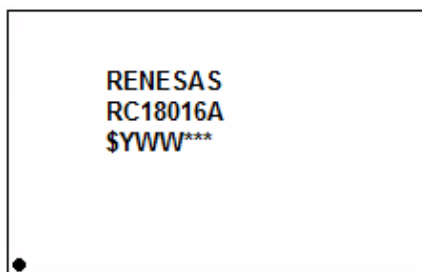

- Line 1 indicates the manufacturer.
- Line 2 indicates the part number.
- Line 3 indicates the following:
 - “Y” is the last digit of the year; “WW” is the work week number when the part was assembled.
 - “\$” denotes the mark code.
 - “***” denotes the last three characters of the assembly lot number.

9. Ordering Information

Part Number	Package Description	Carrier Type	Temperature Range
RC18016AGN1#BB0	9.0 × 9.0 mm, 64-VFQFPN	Tray	-40 to +105°C
RC18016AGN1#HB0		Tape and Reel, Pin 1 Orientation: EIA-481-C	
RC18016AGNC#KB0		Tape and Reel, Pin 1 Orientation: EIA-481-D/E	

Table 42. Pin 1 Orientation in Tape and Reel Packaging

Part Number Suffix	Pin 1 Orientation	Illustration
HB0	Quadrant 1 (EIA-481-C)	
KB0	Quadrant 2 (EIA-481-D/E)	

10. Glossary

Abbreviation	Description
Index <i>x</i>	Denominates a channel, channel frequency divider and the associated configuration bits. Range: A, B, C, D.
Index <i>y</i>	Denominates a QCLK output and associated configuration bits. Range: A0, A1, A2, B0, B1, C0, C1, D.
Index <i>r</i>	Denominates a QREF output and associated configuration bits. Range: A0, A1, A2, B0, B1, C0, C1, D.
V_{DD_V}	Denominates voltage supply pins. Range: V_{DD_QCLKA} , $V_{DD_QREFA01}$, V_{DD_QREFA2} , V_{DD_QCLKB} , V_{DD_QREFB} , V_{DD_QCLKC} , V_{DD_QREFC} , V_{DD_QCLKD} , V_{DD_QREFD} , V_{DD_CLK} , V_{DD_REF} .
[...]	Index brackets describe a group associated with a logical function or a bank of outputs.
{...}	List of discrete values.

11. Revision History

Revision	Date	Description
1.01	Oct 11, 2024	<ul style="list-style-type: none"> Updated item 3 in Device Startup, Reset, and Synchronization. Changed EN_REF_D to EN_QREF_D for register 0x76 in Table 36. Added st_any_ALIGN to Table 40 and Table 41. Updated the description of MD_ALIGN_Φ in Table 41.
1.00	Jul 19, 2024	Initial release.

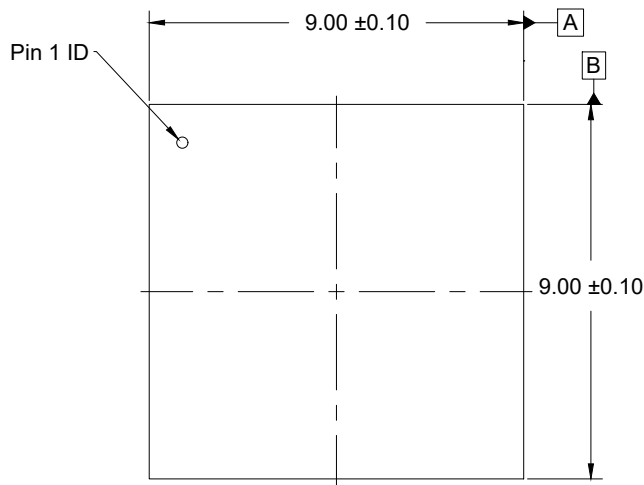

TOP VIEW

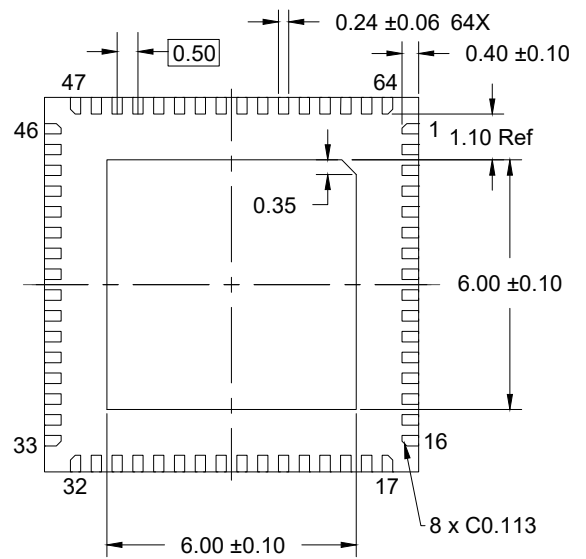

BOTTOM VIEW

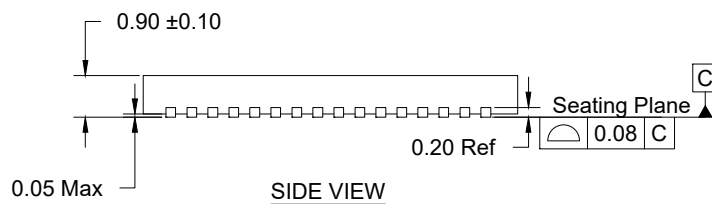

SIDE VIEW

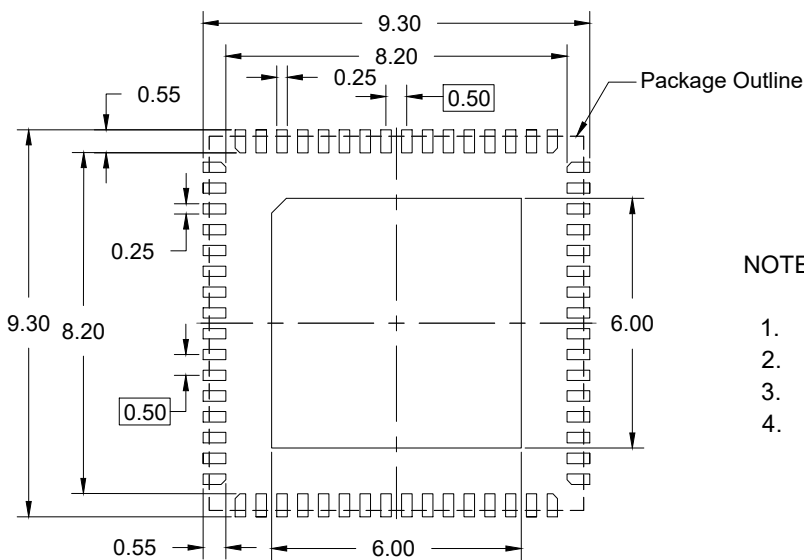

RECOMMENDED LAND PATTERN
(PCB Top View, NSMD Design)

NOTES:

1. JEDEC compatible.
2. All dimensions are in mm and angles are in degrees.
3. Use ± 0.05 mm for the non-toleranced dimensions.
4. Numbers in () are for references only.

IMPORTANT NOTICE AND DISCLAIMER

RENESAS ELECTRONICS CORPORATION AND ITS SUBSIDIARIES (“RENESAS”) PROVIDES TECHNICAL SPECIFICATIONS AND RELIABILITY DATA (INCLUDING DATASHEETS), DESIGN RESOURCES (INCLUDING REFERENCE DESIGNS), APPLICATION OR OTHER DESIGN ADVICE, WEB TOOLS, SAFETY INFORMATION, AND OTHER RESOURCES “AS IS” AND WITH ALL FAULTS, AND DISCLAIMS ALL WARRANTIES, EXPRESS OR IMPLIED, INCLUDING, WITHOUT LIMITATION, ANY IMPLIED WARRANTIES OF MERCHANTABILITY, FITNESS FOR A PARTICULAR PURPOSE, OR NON-INFRINGEMENT OF THIRD-PARTY INTELLECTUAL PROPERTY RIGHTS.

These resources are intended for developers who are designing with Renesas products. You are solely responsible for (1) selecting the appropriate products for your application, (2) designing, validating, and testing your application, and (3) ensuring your application meets applicable standards, and any other safety, security, or other requirements. These resources are subject to change without notice. Renesas grants you permission to use these resources only to develop an application that uses Renesas products. Other reproduction or use of these resources is strictly prohibited. No license is granted to any other Renesas intellectual property or to any third-party intellectual property. Renesas disclaims responsibility for, and you will fully indemnify Renesas and its representatives against, any claims, damages, costs, losses, or liabilities arising from your use of these resources. Renesas' products are provided only subject to Renesas' Terms and Conditions of Sale or other applicable terms agreed to in writing. No use of any Renesas resources expands or otherwise alters any applicable warranties or warranty disclaimers for these products.

(Disclaimer Rev.1.01 Jan 2024)

Corporate Headquarters

TOYOSU FORESIA, 3-2-24 Toyosu,
Koto-ku, Tokyo 135-0061, Japan
www.renesas.com

Trademarks

Renesas and the Renesas logo are trademarks of Renesas Electronics Corporation. All trademarks and registered trademarks are the property of their respective owners.

Contact Information

For further information on a product, technology, the most up-to-date version of a document, or your nearest sales office, please visit www.renesas.com/contact-us/.