

SLG47004

GreenPAK Programmable Mixed-Signal Matrix with In-System Programmability and Advanced Analog Features

General Description

The SLG47004 provides a small, low power component for commonly used analog signal processing and mixed-signal functions. Individual, tunable, analog components used in conjunction with configurable logic provide a way to solve a wide variety of tasks with minimal costs. The user creates their circuit design by programming the multiple time Non-Volatile Memory (NVM) to configure the interconnect logic, the analog and digital macrocell, and the IO Pins of the SLG47004.

Key Features

- Two Programmable Bandwidth Op Amps
 - 3-Op Amp Instrumentation Amplifier Function (including Additional Internal Op Amp)
 - Rail to Rail Input
 - Low Quiescent Current
 - Low Offset Voltage
 - Analog Comparator Mode
 - Optional Vref Voltage Connection for Input Pins
- Two 1024 Position Digital Rheostats
 - User Defined Auto-Trim Option
 - Manual Control Option
 - I²C Control Option
 - Potentiometer Mode
- Two Single-Pole/Single-Throw Analog Switches
 - Voltage or Current Source/Sink Mode
- One Low Offset Chopper Comparator
- Two Low Power General Purpose ACMPs
 - ACMP Sampling Mode
 - Hysteresis with Independently-Selectable Thresholds
- Three Voltage References
 - Two ACMP Vref Output Buffers
 - One High Drive Buffer
- Thirteen Combination Function Macrocells
 - Three Selectable DFF/LATCH or 2-bit LUTs
 - One Selectable Programmable Pattern Generator or 2-bit LUT
 - Seven Selectable DFF/LATCH or 3-bit LUTs
 - One Selectable Pipe Delay or Ripple Counter or 3-bit LUT
- One Selectable DFF/LATCH or 4-bit LUT
- Seven Multi-Function Macrocells
 - Six Selectable DFF/LATCH or 3-bit LUTs + 8-bit Delay/Counters
 - One Selectable DFF/LATCH or 4-bit LUT + 16-bit Delay/Counter
- Serial Communications
 - I²C Protocol Interface
- 2-kbit (256 x 8) I²C-Compatible (2-Wire) Serial EEPROM Emulation with Software Write Protection
- Programmable Delay with Edge Detector Output
- Deglitch Filter or Edge Detector
- Three Oscillators
 - 2.048 kHz Oscillator
 - 2.048 MHz Oscillator
 - 25 MHz Oscillator
- Analog Temperature Sensor
- Power-On Reset
- In-System Programmability
- Multiple Time Programmable Memory
- Wide Range Power Supply
 - 2.5 V (±4 %) to 5 V (±10 %) V_{DD}
- Operating Temperature Range: -40 °C to +85 °C
- RoHS Compliant/Halogen-Free
- Package Available
 - 24-pin STQFN: 3 mm x 3 mm x 0.55 mm, 0.4 mm pitch

Applications

- Adjust Precision Threshold
- Sensor Offset Trimming/Calibration
- Tunable Analog Filters
- Operational Amplifier Adjustable Gain and Offset
- Adjustable Voltage-to-Current Conversions
- Personal Computers and Servers
- PC Peripherals
- Consumer Electronics
- Data Communications Equipment
- Handheld and Portable Electronics
- Smartphones and Fitness Bands
- Notebook and Tablet PCs

Contents

General Description	1
Key Features	1
Applications	1
1 Block Diagram	12
2 Pinout	13
2.1 Pin Configuration - STQFN-24L	13
3 Characteristics	16
3.1 Absolute Maximum Ratings	16
3.2 Electrostatic Discharge Ratings	16
3.3 Recommended Operating Conditions	16
3.4 Electrical Characteristics	17
3.5 I ² C Pins Characteristics	22
3.6 Macrocells Current Consumption	24
3.7 Timing Characteristics	25
3.8 Oscillator Characteristics	27
3.9 ACMP Characteristics	27
3.10 Internal Vref Characteristics	28
3.11 Output Buffers Characteristics	28
3.12 Analog Temperature Sensor Characteristics	30
3.13 Programmable Operational Amplifier Characteristics	31
3.14 100K Digital Rheostat Characteristics	35
3.15 Analog Switches Characteristics	36
4 User Programmability	38
5 IO Pins	39
5.1 GPIO Pins	39
5.2 GPI Pins	39
5.3 Pull-Up/Down Resistors	39
5.4 Fast Pull-Up/Down during Power-Up	39
5.5 I2C Mode IO Structure	40
5.6 Matrix OE IO Structure	41
5.7 GPI Structure	42
5.8 IO Pins Typical Performance	43
6 Connection Matrix	46
6.1 Matrix Input Table	47
6.2 Matrix Output Table	48
6.3 Connection Matrix Virtual Inputs	51
6.4 Connection Matrix Virtual Outputs	52
7 Combination Function Macrocells	53
7.1 2-Bit LUT or D Flip-Flop Macrocells	53
7.2 2-bit LUT or Programmable Pattern Generator	56
7.3 3-Bit LUT or D Flip-Flop with Set/Reset Macrocells	58
7.4 4-Bit LUT or D Flip-Flop with Set/Reset Macrocell	66
7.5 3-Bit LUT or Pipe Delay/Ripple Counter Macrocell	68
8 Multi-Function Macrocells	72
8.1 3-Bit LUT or DFF/Latch with 8-Bit Counter/Delay Macrocells	72
8.2 4-Bit LUT or DFF/Latch with 16-Bit Counter/Delay Macrocell	81
8.3 CNT/DLY/FSM Timing Diagrams	84
8.4 Wake and Sleep Controller	93
9 Analog Comparators	97
9.1 Analog Comparators Overview	97
9.2 Chopper Analog Comparator	99
9.3 ACMP Sampling Mode	101
9.4 ACMP Typical Performance	102
10 Programmable Operational Amplifiers	105
10.1 General Description	105

10.2 Modes of Operation	107
10.3 Op Amps Typical Performance	111
11 Analog Switch Macrocell	157
11.1 Analog Switch General Description	157
11.2 Half Bridge Mode	159
11.3 Analog Switches Typical Performance	160
12 Digital Rheostats and Programmable Trim Block	162
12.1 Potentiometer Mode	165
12.2 Calculating Actual Resistance	165
12.3 Digital Rheostat Value Self-programming into the NVM	166
12.4 Trimming process Using Programmable Trim Block	169
12.5 Using Chopper ACMP	175
13 Programmable Delay/Edge Detector	181
13.1 Programmable Delay Timing Diagram - Edge Detector Output	181
14 Additional Logic Function. Deglitch Filter	182
15 Voltage Reference	183
15.1 Voltage Reference Overview	183
15.2 Vref Selection Table	183
15.3 Vref Block Diagram	185
15.4 Voltage Reference Typical Performance	189
15.5 HD Buffer Typical Performance	192
16 Clocking	196
16.1 OSC General Description	196
16.2 Oscillator0 (2.048 kHz)	197
16.3 Oscillator1 (2.048 MHz)	198
16.4 Oscillator2 (25 MHz)	199
16.5 CNT/DLY Clock Scheme	199
16.6 External Clocking	200
16.7 Oscillators Power-On Delay	201
16.8 Oscillators Accuracy	203
16.9 Oscillators Settling time	205
16.10 Oscillators Current Consumption	207
17 Power-On Reset	212
17.1 General Operation	212
17.2 POR Sequence	213
17.3 Macrocells Output States During POR Sequence	213
18 I²C Serial Communications Macrocell	216
18.1 I ² C Serial Communications Macrocell Overview	216
18.2 I ² C Serial Communications Device Addressing	216
18.3 I ² C Serial General Timing	217
18.4 I ² C Serial Communications Commands	217
18.5 Chip Configuration Data Protection	220
18.6 I ² C Serial Command Register Map	221
18.7 I ² C Additional Options	224
19 Non-Volatile Memory	226
19.1 Serial NVM Write Operations	226
19.2 Serial NVM Read Operations	228
19.3 Serial NVM Erase Operations	228
19.4 Acknowledge Polling	229
19.5 Low power standby mode	229
19.6 Emulated EEPROM Write Protection	229
20 Analog Temperature Sensor	231
21 Register Definitions	234
21.1 Register Map	234
22 Package Top Marking System Definition	293
22.1 STQFN-24L 3 mm x 3 mm x 0.55 mm, 0.4P FCD Package	293
23 Package Information	294

SLG47004

GreenPAK Programmable Mixed-Signal Matrix with In-System Programmability and Advanced Analog Features

23.1 Package outlines FOR STQFN 24L 3 mm x 3 mm x 0.55 mm 0.4P Green Package	294
23.2 STQFN Handling	294
23.3 Soldering Information	294
24 Ordering Information	295
24.1 Tape and Reel Specifications	295
24.2 Carrier Tape Drawing and Dimensions	295
25 Layout Guidelines	297
25.1 STQFN 24L 3 mm x 3 mm x 0.55 mm 0.4P Green Package	297
Glossary	298
Revision History	301

Figures

Figure 1: Block Diagram.....	12
Figure 2: Steps to Create a Custom GreenPAK Device.....	38
Figure 3: IO with I ² C Mode IO Structure Diagram.....	40
Figure 4: Matrix OE IO Structure Diagram.....	41
Figure 5: IO0 GPI Structure Diagram.....	42
Figure 6: Typical High Level Output Current vs. High Level Output Voltage at T = 25 °C.....	43
Figure 7: Typical Low Level Output Current vs. Low Level Output Voltage, 1x Drive at T = 25 °C, Full Range.....	43
Figure 8: Typical Low Level Output Current vs. Low Level Output Voltage, 1x Drive at T = 25 °C.....	44
Figure 9: Typical Low Level Output Current vs. Low Level Output Voltage, 2x Drive at T = 25 °C, Full Range.....	44
Figure 10: Typical Low Level Output Current vs. Low Level Output Voltage, 2x Drive at T = 25 °C.....	45
Figure 11: Connection Matrix.....	46
Figure 12: Connection Matrix Example.....	46
Figure 13: 2-bit LUT0 or DFF0.....	53
Figure 14: 2-bit LUT1 or DFF1.....	54
Figure 15: 2-bit LUT2 or DFF2.....	54
Figure 16: DFF Polarity Operations.....	56
Figure 17: 2-bit LUT3 or PGen.....	57
Figure 18: PGen Timing Diagram.....	57
Figure 19: 3-bit LUT0 or DFF3.....	59
Figure 20: 3-bit LUT1 or DFF4.....	60
Figure 21: 3-bit LUT2 or DFF5.....	60
Figure 22: 3-bit LUT3 or DFF6.....	61
Figure 23: 3-bit LUT4 or DFF7.....	61
Figure 24: 3-bit LUT5 or DFF8.....	62
Figure 25: 3-bit LUT6 or DFF9.....	62
Figure 26: DFF Polarity Operations with nReset.....	65
Figure 27: DFF Polarity Operations with nSet.....	66
Figure 28: 4-bit LUT0 or DFF10.....	67
Figure 29: 3-bit LUT13/Pipe Delay/Ripple Counter.....	69
Figure 30: Example: Ripple Counter Functionality.....	70
Figure 31: Possible Connections Inside Multi-Function Macrocell.....	72
Figure 32: 8-bit Multi-Function Macrocells Block Diagram (3-bit LUT7/DFF11, CNT/DLY1).....	73
Figure 33: 8-bit Multi-Function Macrocells Block Diagram (3-bit LUT8/DFF12, CNT/DLY2).....	74
Figure 34: 8-bit Multi-Function Macrocells Block Diagram (3-bit LUT9/DFF13, CNT/DLY3).....	75
Figure 35: 8-bit Multi-Function Macrocells Block Diagram (3-bit LUT10/DFF14, CNT/DLY4).....	76
Figure 36: 8-bit Multi-Function Macrocells Block Diagram (3-bit LUT11/DFF15, CNT/DLY5).....	77
Figure 37: 8-bit Multi-Function Macrocells Block Diagram (3-bit LUT12/DFF16, CNT/DLY6).....	78
Figure 38: 4-bit LUT1 or CNT/DLY0.....	82
Figure 39: Delay Mode Timing Diagram, Edge Select: Both, Counter Data: 3.....	84
Figure 40: Delay Mode Timing Diagram for Different Edge Select Modes.....	85
Figure 41: Counter Mode Timing Diagram without Two DFFs Synced Up.....	85
Figure 42: Counter Mode Timing Diagram with Two DFFs Synced Up.....	86
Figure 43: One-Shot Function Timing Diagram.....	87
Figure 44: Frequency Detection Mode Timing Diagram.....	88
Figure 45: Edge Detection Mode Timing Diagram.....	89
Figure 46: Delayed Edge Detection Mode Timing Diagram.....	90
Figure 47: CNT/FSM Timing Diagram (Reset Rising Edge Mode, Oscillator is Forced On, UP = 0) for Counter Data = 3.....	90
Figure 48: CNT/FSM Timing Diagram (Set Rising Edge Mode, Oscillator is Forced On, UP = 0) for Counter Data = 3.....	91
Figure 49: CNT/FSM Timing Diagram (Reset Rising Edge Mode, Oscillator is Forced On, UP = 1) for Counter Data = 3.....	91
Figure 50: CNT/FSM Timing Diagram (Set Rising Edge Mode, Oscillator is Forced On, UP = 1) for Counter Data = 3.....	92
Figure 51: Counter Value, Counter Data = 3.....	92
Figure 52: Wake and Sleep Controller.....	93
Figure 53: Wake and Sleep Timing Diagram, Normal Wake Mode, Counter Reset is Used.....	94
Figure 54: Wake and Sleep Timing Diagram, Short Wake Mode, Counter Reset is Used.....	94
Figure 55: Wake and Sleep Timing Diagram, Normal Wake Mode, Counter Set is Used.....	95

**GreenPAK Programmable Mixed-Signal Matrix
with In-System Programmability and Advanced Analog Features**

Figure 56: Wake and Sleep Timing Diagram, Short Wake Mode, Counter Set is Used	95
Figure 57: ACMP0L Block Diagram	98
Figure 58: ACMP1L Block Diagram	99
Figure 59: Chopper ACMP Block Diagram.....	101
Figure 60: Propagation Delay vs. Vref for ACMPx at T = 25 °C, V _{DD} = 2.4 V to 5.5 V, Hysteresis = 0	102
Figure 61: ACMPx Power-On Delay vs. V _{DD} at BG - Forced.....	102
Figure 62: ACMPx Input Offset Voltage vs. Vref at T = -40 °C to 85 °C, V _{DD} = 2.4 V to 5.5 V, Gain = 1	103
Figure 63: Chopper ACMP Input Offset Voltage vs. Vref at T = -40 °C to 85 °C, V _{DD} = 2.4 V to 5.5 V, Gain = 1	103
Figure 64: ACMPx Current Consumption vs. V _{DD}	104
Figure 65: Chopper ACMP Current Consumption vs. V _{DD} (with 2.048 kHz Clock).....	104
Figure 66: Programmable Operational Amplifier OA0, OA1 Internal Circuit	105
Figure 67: Internal Operational Amplifier Circuit	106
Figure 68: Example of Input Offset Voltage Compensation	107
Figure 69: Instrumentation Amplifier Structure.....	108
Figure 70: Instrumentation Operational Amplifier Configuration for Users Trim.....	109
Figure 71: Typical Implementation of Voltage Regulator (A) and Current Sources (B, C).....	110
Figure 72: Constant Current Sink.....	111
Figure 73: Op Ampx Input Offset Voltage vs. T _A at Input CM Voltage = V _{DD} /2, BW = 128 kHz.....	111
Figure 74: Op Ampx Input Offset Voltage vs. T _A at Input CM Voltage = V _{DD} /2, BW = 512 kHz.....	112
Figure 75: Op Ampx Input Offset Voltage vs. T _A at Input CM Voltage = V _{DD} /2, BW = 2 MHz	112
Figure 76: Op Ampx Input Offset Voltage vs. T _A at Input CM Voltage = V _{DD} /2, BW = 8 MHz	113
Figure 77: Internal Op Amp Input Offset Voltage vs. T _A at Input CM Voltage = V _{DD} /2, BW = 128 kHz	113
Figure 78: Internal Op Amp _A at Input CM Voltage = V _{DD} /2, BW = 512 kHz.....	114
Figure 79: Internal Op Amp _A at Input CM Voltage = V _{DD} /2, BW = 2 MHz	114
Figure 80: Internal Op Amp Input Offset Voltage vs. T _A at Input CM Voltage = V _{DD} /2, BW = 8 MHz	115
Figure 81: OpAmp0, 1 Input Offset Voltage vs. Input CM Voltage at T = 25 °C, V _{DDA} = 2.4 V.....	115
Figure 82: OpAmp0, 1 Input Offset Voltage vs. Input CM Voltage at T = 25 °C, V _{DDA} = 5.5 V.....	116
Figure 83: Internal OpAmp Input Offset Voltage vs. Input CM Voltage at T = 25 °C, V _{DDA} = 2.4 V.....	116
Figure 84: Internal OpAmp Input Offset Voltage vs. Input CM Voltage at T = 25 °C, V _{DDA} = 5.5 V.....	117
Figure 85: Quiescent Current vs. Power Supply Voltage for BW = 128 kHz.....	117
Figure 86: Quiescent Current vs. Power Supply Voltage for BW = 512 kHz.....	118
Figure 87: Quiescent Current vs. Power Supply Voltage for BW = 2 MHz	118
Figure 88: Quiescent Current vs. Power Supply Voltage or BW = 8 MHz	119
Figure 89: OA0 Open Loop Gain and Phase vs. Frequency for BW = 128 kHz	119
Figure 90: OA0 Open Loop Gain and Phase vs. Frequency for BW = 512 kHz	120
Figure 91: OA0 Open Loop Gain and Phase vs. Frequency for BW = 2 MHz	120
Figure 92: OA0 Open Loop Gain and Phase vs. Frequency for BW = 8 MHz	121
Figure 93: OA1 Open Loop Gain and Phase vs. Frequency for BW = 128 kHz	121
Figure 94: OA1 Open Loop Gain and Phase vs. Frequency for BW = 512 kHz	122
Figure 95: OA1 Open Loop Gain and Phase vs. Frequency for BW = 2 MHz	122
Figure 96: OA1 Open Loop Gain and Phase vs. Frequency for BW = 8 MHz	123
Figure 97: PSRR vs. Frequency V _{DD} = 2.4 V to 5.5 V	123
Figure 98: 0.1 Hz to 10 Hz Noise, BW = 128 kHz	124
Figure 99: 0.1 Hz to 10 Hz Noise, BW = 512 kHz	124
Figure 100: 0.1 Hz to 10 Hz Noise, BW = 2 MHz.....	125
Figure 101: 0.1 Hz to 10 Hz Noise, BW = 8 MHz.....	125
Figure 102: Channel Separation vs. Frequency.....	126
Figure 103: Op Ampx Noise Voltage Density vs. Frequency.....	126
Figure 104: Slew Rate vs. Ambient Temperature G = 1 V/V; R _L = 50 kΩ for BW = 128 kHz.....	127
Figure 105: Slew Rate vs. Ambient Temperature G = 1 V/V; R _L = 50 kΩ for BW = 512 kHz.....	127
Figure 106: Slew Rate vs. Ambient Temperature G = 1 V/V; R _L = 50 kΩ for BW = 2 MHz	128
Figure 107: Slew Rate vs. Ambient Temperature G = 1 V/V; R _L = 50 kΩ for BW = 8 MHz	128
Figure 108: Small Signal Inverting Step Response G = -1 V/V, R _L = 50 kΩ, C _L = 60 pF, BW = 128 kHz	129
Figure 109: Small Signal Inverting Step Response G = -1 V/V, R _L = 50 kΩ, C _L = 60 pF, BW = 512 kHz	129
Figure 110: Small Signal Inverting Step Response G = -1 V/V, R _L = 50 kΩ, C _L = 60 pF, BW = 2 MHz.....	130
Figure 111: Small Signal Inverting Step Response G = -1 V/V, R _L = 50 kΩ, C _L = 60 pF, BW = 8 MHz.....	130
Figure 112: Small Signal Non-Inverting Step Response G = -1 V/V, R _L = 50 kΩ, C _L = 60 pF, BW = 128 kHz	131

**GreenPAK Programmable Mixed-Signal Matrix
with In-System Programmability and Advanced Analog Features**

Figure 113: Small Signal Non-Inverting Step Response $G = -1$ V/V, $R_L = 50$ k Ω , $C_L = 60$ pF, BW = 512 kHz	131
Figure 114: Small Signal Non-Inverting Step Response $G = -1$ V/V, $R_L = 50$ k Ω , $C_L = 60$ pF, BW = 2 MHz	132
Figure 115: Small Signal Non-Inverting Step Response $G = -1$ V/V, $R_L = 50$ k Ω , $C_L = 60$ pF, BW = 8 MHz	132
Figure 116: Large Signal Inverting Step Response $G = -1$ V/V, $R_L = 50$ k Ω , $C_L = 80$ pF, BW = 128 kHz	133
Figure 117: Large Signal Inverting Step Response $G = -1$ V/V, $R_L = 50$ k Ω , $C_L = 80$ pF, BW = 512kHz	133
Figure 118: Large Signal Inverting Step Response $G = -1$ V/V, $R_L = 50$ k Ω , $C_L = 80$ pF, BW = 2 MHz	134
Figure 119: Large Signal Inverting Step Response $G = -1$ V/V, $R_L = 50$ k Ω , $C_L = 80$ pF, BW = 8 MHz	134
Figure 120: Large Signal Non-Inverting Step Response $G = -1$ V/V, $R_L = 50$ k Ω , $C_L = 60$ pF, BW = 128 kHz	135
Figure 121: Large Signal Non-Inverting Step Response $G = -1$ V/V, $R_L = 50$ k Ω , $C_L = 60$ pF, BW = 512 kHz	135
Figure 122: Large Signal Non-Inverting Step Response $G = -1$ V/V, $R_L = 50$ k Ω , $C_L = 60$ pF, BW = 2 MHz	136
Figure 123: Large Signal Non-Inverting Step Response $G = -1$ V/V, $R_L = 50$ k Ω , $C_L = 60$ pF, BW = 8 MHz	136
Figure 124: Inverting Overload Recovery $G = -1$ V/V, $R_L = 50$ k Ω , $C_L = 60$ pF, BW = 128 kHz	137
Figure 125: Inverting Overload Recovery $G = -1$ V/V, $R_L = 50$ k Ω , $C_L = 60$ pF, BW = 512 kHz	137
Figure 126: Inverting Overload Recovery $G = -1$ V/V, $R_L = 50$ k Ω , $C_L = 60$ pF, BW = 2 MHz	138
Figure 127: Inverting Overload Recovery $G = -1$ V/V, $R_L = 50$ k Ω , $C_L = 60$ pF, BW = 8 MHz	138
Figure 128: Non-Inverting Overload Recovery $G = -1$ V/V, $R_L = 50$ k Ω , $C_L = 60$ pF, BW = 128 kHz	139
Figure 129: Non-Inverting Overload Recovery $G = -1$ V/V, $R_L = 50$ k Ω , $C_L = 60$ pF, BW = 512 kHz	139
Figure 130: Non-Inverting Overload Recovery $G = -1$ V/V, $R_L = 50$ k Ω , $C_L = 60$ pF, BW = 2 MHz	140
Figure 131: Non-Inverting Overload Recovery $G = -1$ V/V, $R_L = 50$ k Ω , $C_L = 60$ pF, BW = 8 MHz	140
Figure 132: Small Signal Overshoot vs. Capacitive Load $V_{DD} = 3.3$ V, $G = 1$ V/V, BW = 128 kHz	141
Figure 133: Small Signal Overshoot vs. Capacitive Load $V_{DD} = 3.3$ V, $G = 1$ V/V, BW = 512 kHz	141
Figure 134: Small Signal Overshoot vs. Capacitive Load $V_{DD} = 3.3$ V, $G = 1$ V/V, BW = 2 MHz	142
Figure 135: Small Signal Overshoot vs. Capacitive Load $V_{DD} = 3.3$ V, $G = 1$ V/V, BW = 8 MHz	142
Figure 136: Output Voltage Low ($V_{OUT} - GND$) vs. Temperature at BW = 128 kHz, $R_{LOAD} = 600$ Ω	143
Figure 137: Output Voltage Low ($V_{OUT} - GND$) vs. Temperature at BW = 128 kHz, $R_{LOAD} = 50$ k Ω	143
Figure 138: Output Voltage High ($V_{DDA} - V_{OUT}$) vs. Temperature at BW = 128 kHz, $R_{LOAD} = 600$ Ω	144
Figure 139: Output Voltage High ($V_{DDA} - V_{OUT}$) vs. Temperature at BW = 128 kHz, $R_{LOAD} = 50$ k Ω	144
Figure 140: Output Voltage Low ($V_{OUT} - GND$) vs. Temperature at BW = 512 kHz, $R_{LOAD} = 600$ Ω	145
Figure 141: Output Voltage Low ($V_{OUT} - GND$) vs. Temperature at BW = 512 kHz, $R_{LOAD} = 50$ k Ω	145
Figure 142: Output Voltage High ($V_{DDA} - V_{OUT}$) vs. Temperature at BW = 512 kHz, $R_{LOAD} = 600$ Ω	146
Figure 143: Output Voltage High ($V_{DDA} - V_{OUT}$) vs. Temperature at BW = 512kHz, $R_{LOAD} = 50$ k Ω	146
Figure 144: Output Voltage Low ($V_{OUT} - GND$) vs. Temperature at BW = 2 MHz, $R_{LOAD} = 600$ Ω	147
Figure 145: Output Voltage Low ($V_{OUT} - GND$) vs. Temperature at BW = 2 MHz, $R_{LOAD} = 50$ k Ω	147
Figure 146: Output Voltage High ($V_{DDA} - V_{OUT}$) vs. Temperature at BW = 2 MHz, $R_{LOAD} = 600$ Ω	148
Figure 147: Output Voltage High ($V_{DDA} - V_{OUT}$) vs. Temperature at BW = 2 MHz, $R_{LOAD} = 50$ k Ω	148
Figure 148: Output Voltage Low ($V_{OUT} - GND$) vs. Temperature at BW = 8MHz, $R_{LOAD} = 600$ Ω	149
Figure 149: Output Voltage Low ($V_{OUT} - GND$) vs. Temperature at BW = 8 MHz, $R_{LOAD} = 50$ k Ω	149
Figure 150: Output Voltage High ($V_{DDA} - V_{OUT}$) vs. Temperature at BW = 8 MHz, $R_{LOAD} = 600$ Ω	150
Figure 151: Output Voltage High ($V_{DDA} - V_{OUT}$) vs. Temperature at BW = 8 MHz, $R_{LOAD} = 50$ k Ω	150
Figure 152: Overload Recovery Time vs. Power Supply Voltage $R_L = 50$ k Ω ; $G = 1$ V/V, Rising	151
Figure 153: Overload Recovery Time vs. Power Supply Voltage $R_L = 50$ k Ω ; $G = 1$ V/V, Falling	151
Figure 154: Output Response to Power Down Signal $G = 1$ V/V; $R_L = 50$ k Ω ; $C_L = 20$ pF; $V_{IN} = V_S/2$, BW = 128 kHz	152
Figure 155: Output Response to Power Down Signal $G = 1$ V/V; $R_L = 50$ k Ω ; $C_L = 20$ pF; $V_{IN} = V_S/2$, BW = 512 kHz	152
Figure 156: Output Response to Power Down Signal $G = 1$ V/V; $R_L = 50$ k Ω ; $C_L = 20$ pF; $V_{IN} = V_S/2$, BW = 2 MHz	153
Figure 157: Output Response to Power Down Signal $G = 1$ V/V; $R_L = 50$ k Ω ; $C_L = 20$ pF; $V_{IN} = V_S/2$, BW = 8 MHz	153
Figure 158: Opampx Turn-On/Off Time vs. V_{DD} at $V_{IN} = V_{DD}/2$, BW = 128 kHz	154
Figure 159: Opampx Turn-On/Off Time vs. V_{DD} at $V_{IN} = V_{DD}/2$, BW = 512 kHz	154
Figure 160: Opampx Turn-On/Off Time vs. V_{DD} at $V_{IN} = V_{DD}/2$, BW = 2 MHz	155
Figure 161: Opampx Turn-On/Off Time vs. V_{DD} at $V_{IN} = V_{DD}/2$, BW = 8 MHz	155
Figure 162: Opamps Quiescent Current Consumption vs. V_{DD}	156
Figure 163: Analog Switch 0 Control Circuit	157
Figure 164: Analog Switch 1 Control Circuit	158
Figure 165: Structure of Half Bridge	159
Figure 166: Typical R_{ON} vs. Input Voltage (V_i) for $V_i = 0$ to V_{DDA} , $I_{LOAD} = 1$ mA, $V_{DDA} = 2.4$ V	160
Figure 167: Typical R_{ON} vs. Input Voltage (V_i) for $V_i = 0$ to V_{DDA} , $I_{LOAD} = 1$ mA, $V_{DDA} = 5.5$ V	160
Figure 168: Turn-On Time vs. V_{DD} at $R_{LOAD} = 100$ Ω to GND, $V_{IN} = V_{DD}/2$	161
Figure 169: Turn-Off Time vs. V_{DD} at $R_{LOAD} = 100$ Ω to GND, $V_{IN} = V_{DD}/2$	161

**GreenPAK Programmable Mixed-Signal Matrix
with In-System Programmability and Advanced Analog Features**

Figure 170: Programmable Trim Blocks and Digital Rheostat's Internal Circuit.....	164
Figure 171: Rheostats in Potentiometer Mode.....	165
Figure 172: Rheostat Tolerance Registers.....	166
Figure 173: Flowchart of "Program" and "Reload" Signals.....	167
Figure 174: Example of Latching and Processing "Program" and "Reload" Signals.....	168
Figure 175: Example of Auto-Trim Process for a Single Rheostat.....	170
Figure 176: Example of Auto-Trim Process with External Clock Signal.....	171
Figure 177: Example of Auto-Trim Process for Two Rheostats.....	172
Figure 178: Example of Auto-Trim Process via I ² C.....	173
Figure 179: Example of Hardware Configuration.....	174
Figure 180: Example of User Specific Trimming Process under I ² C Master Control.....	175
Figure 181: DNL vs. Digital Code, Rheostat Mode (V _{AB} = 1 V) at T = 25 °C.....	176
Figure 182: INL vs. Digital Code, Rheostat Mode (V _{AB} = 1 V) at T = 25 °C.....	176
Figure 183: DNL vs. Digital Code, Potentiometer Mode (V _{AB} = 1 V) at T = 25 °C.....	177
Figure 184: INL vs. Digital Code, Potentiometer Mode (V _{AB} = 1 V) at T = 25 °C.....	177
Figure 185: (ΔR _{AB} /R _{AB})/ΔT _A Rheostat Mode Tempco.....	178
Figure 186: RHx Zero Scale Error vs. Temperature (V _{IN} = 1 V).....	178
Figure 187: Transition Glitch in Worst Case (Code = 511 to Code = 512).....	179
Figure 188: Gain vs. Frequency (Code = 512) at T = 25 °C, V _{DDA} = 5 V.....	179
Figure 189: RHx Settling Time vs. V _{DD} at I _{LOAD} = 1 mA, T = 25 °C.....	180
Figure 190: Programmable Delay.....	181
Figure 191: Edge Detector Output.....	181
Figure 192: Deglitch Filter or Edge Detector.....	182
Figure 193: Generalized Vref Structure.....	185
Figure 194: ACMP0L, ACMP1L Voltage Reference Block Diagram.....	186
Figure 195: HD Buffer and Chopper ACMP Reference Block Diagram.....	187
Figure 196: Operational Amplifiers Voltage Reference Block Diagram.....	188
Figure 197: Typical Load Regulation, Vref = 320 mV, T = -40 °C to +85 °C, Buffer - Enable.....	189
Figure 198: Typical Load Regulation, Vref = 640 mV, T = -40 °C to +85 °C, Buffer - Enable.....	189
Figure 199: Typical Load Regulation, Vref = 1280 mV, T = -40 °C to +85 °C, Buffer - Enable.....	190
Figure 200: Typical Load Regulation, Vref = 2048 mV, T = -40 °C to +85 °C, Buffer - Enable.....	190
Figure 201: Typical Input Offset Voltage vs. Vref at V _{DD} = 2.4 V to 5.5 V, T = 25 °C, Buffer Disabled.....	191
Figure 202: Op Ampx Vref Divider Accuracy at V _{DD} = 3.3 V.....	191
Figure 203: HD Buffer Typical Load Regulation, Vref = 320 mV, T = -40 °C to +85 °C.....	192
Figure 204: HD Buffer Typical Load Regulation, Vref = 640 mV, T = -40 °C to +85 °C.....	192
Figure 205: HD Buffer Typical Load Regulation, Vref = 1280 mV, T = -40 °C to +85 °C.....	193
Figure 206: HD Buffer Typical Load Regulation, Vref = 2048 mV, T = -40 °C to +85 °C.....	193
Figure 207: HD Buffer Typical Line Regulation, I _{LOAD} = 5 mA.....	194
Figure 208: HD Buffer Offset vs. V _{DD}	194
Figure 209: HD Buffer Output Short-Circuit Current vs. V _{DD}	195
Figure 210: Oscillator0 Block Diagram.....	197
Figure 211: Oscillator1 Block Diagram.....	198
Figure 212: Oscillator2 Block Diagram.....	199
Figure 213: Clock Scheme.....	200
Figure 214: Oscillator Startup Diagram.....	201
Figure 215: OSC0 Maximum Power-On Delay vs. V _{DD} at T = 25 °C, OSC0 = 2.048 kHz.....	201
Figure 216: OSC1 Oscillator Maximum Power-On Delay vs. V _{DD} at T = 25 °C, OSC1 = 2.048 MHz.....	202
Figure 217: OSC2 Maximum Power-On Delay vs. V _{DD} at T = 25 °C, OSC2 = 25 MHz.....	202
Figure 218: OSC0 Frequency vs. Temperature, OSC0 = 2.048 kHz.....	203
Figure 219: OSC1 Frequency vs. Temperature, OSC1 = 2.048 MHz.....	203
Figure 220: OSC2 Frequency vs. Temperature, OSC2 = 25 MHz.....	204
Figure 221: Oscillators Total Error vs. Temperature at V _{DD} = 2.4 V to 5.5 V.....	204
Figure 222: Oscillator0 Settling Time, V _{DD} = 3.3 V, T = 25 °C, OSC0 = 2 kHz.....	205
Figure 223: Oscillator1 Settling Time, V _{DD} = 3.3 V, T = 25 °C, OSC1 = 2 MHz.....	205
Figure 224: Oscillator2 Settling Time, V _{DD} = 3.3 V, T = 25 °C, OSC2 = 25 MHz (Normal Start).....	206
Figure 225: Oscillator2 Settling Time, V _{DD} = 3.3 V, T = 25 °C, OSC2 = 25 MHz (Start with Delay).....	206
Figure 226: OSC0 Current Consumption vs. V _{DD} at T = -40 °C to +85 °C (All Pre-Dividers).....	207

**GreenPAK Programmable Mixed-Signal Matrix
with In-System Programmability and Advanced Analog Features**

Figure 227: OSC1 Current Consumption vs. V_{DD} (Pre-Divider = 1).....	208
Figure 228: OSC1 Current Consumption vs. V_{DD} (Pre-Divider = 4).....	209
Figure 229: OSC1 Current Consumption vs. V_{DD} (Pre-Divider = 8).....	209
Figure 230: OSC2 Current Consumption vs. V_{DD} (Pre-Divider = 1).....	210
Figure 231: OSC2 Current Consumption vs. V_{DD} (Pre-Divider = 4).....	210
Figure 232: OSC2 Current Consumption vs. V_{DD} (Pre-Divider = 8).....	211
Figure 233: POR Sequence	213
Figure 234: Internal Macrocell States During POR Sequence.....	214
Figure 235: Power-Down.....	215
Figure 236: Basic Command Structure	216
Figure 237: I ² C General Timing Characteristics.....	217
Figure 238: Byte Write Command, R/W = 0.....	217
Figure 239: Sequential Write Command	218
Figure 240: Current Address Read Command, R/W = 1.....	218
Figure 241: Random Read Command	219
Figure 242: Sequential Read Command.....	219
Figure 243: Reset Command Timing	220
Figure 244: Example of I ² C Byte Write Bit Masking.....	225
Figure 245: Page Write Command.....	227
Figure 246: I ² C Block Addressing	228
Figure 247: Analog Temperature Sensor Structure Diagram.....	232
Figure 248: TS Output vs. Temperature, V_{DD} = 3.3 V	233

Tables

Table 1: Functional Pin Description.....	13
Table 2: Pin Type Definitions	15
Table 3: Absolute Maximum Ratings.....	16
Table 4: Electrostatic Discharge Ratings	16
Table 5: Recommended Operating Conditions	16
Table 6: EC at T = -40 °C to +85 °C, V _{DD} = 2.4 V to 5.5 V Unless Otherwise Noted	17
Table 7: EC of the I ² C Pins for DI at T = -40 °C to +85 °C, V _{DD} = 2.4 V to 5.5 V Unless Otherwise Noted	22
Table 8: EC of the I ² C Pins for DILV at T = -40 °C to +85 °C, V _{DD} = 2.4 V to 5.5 V Unless Otherwise Noted	23
Table 9: I ² C Pins Timing Characteristics at T = -40 °C to +85 °C, V _{DD} = 2.4 V to 5.5 V Unless Otherwise Noted.....	23
Table 10: Typical Current Estimated for Each Macrocell at T = 25 °C.....	24
Table 11: Typical Delay Estimated for Each Macrocell at T = 25 °C.....	25
Table 12: Programmable Delay Expected Typical Delays and Widths at T = 25 °C.....	26
Table 13: Typical Filter Rejection Pulse Width at T = 25 °C	26
Table 14: Typical Counter/Delay Offset Measurements at T = 25 °C	26
Table 15: Oscillators Frequency Limits, V _{DD} = 2.4 V to 5.5 V.....	27
Table 16: Oscillators Power-On Delay at T = 25 °C, OSC Power Setting: "Auto Power-On"	27
Table 17: ACMP Specifications at T = -40 °C to +85 °C, V _{DD} = 2.4 V to 5.5 V Unless Otherwise Noted.....	27
Table 18: Internal Vref Characteristics at V _{DD} = 2.4 V to 5.5 V	28
Table 19: HD Buffer Electrical Characteristics at T = -40 °C to +85 °C, V _{DD} = 2.4 V to 5.5 V Unless Otherwise Noted	28
Table 20: Vref Output Buffer at T = -40 °C to +85 °C, V _{DD} = 2.4 V to 5.5 V Unless Otherwise Noted	29
Table 21: TS Output vs Temperature (Output Range 1)	30
Table 22: TS Output vs Temperature (Output Range 2)	30
Table 23: EC of OA, V _{DDA} = 2.4 V to 5.5 V, V _{CM} = V _{DDA} /2, V _{OUT} ≈ V _{DDA} /2, R _L = 100 kΩ to V _{DDA} /2, C _L = 50 pF, T = 25 °C. 31	
Table 24: 100K Digital Rheostat EC at V _A =V _{DD} , V _B =GND, T=-40°C to +85°C, V _{DD} =2.4V to 5.5V Unless Otherwise Noted . 35	
Table 25: Analog Switch0/Voltage Regulator EC at T = -40 °C to +85 °C, V _{DD} = 2.4 V to 5.5 V Unless Otherwise Noted..... 36	
Table 26: Analog Switch1/Current Sink EC at T = -40 °C to +85 °C, V _{DD} = 2.4 V to 5.5 V Unless Otherwise Noted..... 37	
Table 27: Matrix Input Table.....	47
Table 28: Matrix Output Table.....	48
Table 29: Connection Matrix Virtual Inputs	52
Table 30: 2-bit LUT0 Truth Table	55
Table 31: 2-bit LUT1 Truth Table	55
Table 32: 2-bit LUT2 Truth Table	55
Table 33: 2-bit LUT Standard Digital Functions	55
Table 34: 2-bit LUT1 Truth Table	58
Table 35: 2-bit LUT Standard Digital Functions	58
Table 36: 3-bit LUT0 Truth Table	63
Table 37: 3-bit LUT1 Truth Table	63
Table 38: 3-bit LUT2 Truth Table.....	63
Table 39: 3-bit LUT3 Truth Table	63
Table 40: 3-bit LUT4 Truth Table	63
Table 41: 3-bit LUT5 Truth Table	63
Table 42: 3-bit LUT6 Truth Table	63
Table 43: 3-bit LUT Standard Digital Functions	64
Table 44: 4-bit LUT0 Truth Table	67
Table 45: 4-bit LUT Standard Digital Functions	68
Table 46: 3-bit LUT13 Truth Table	70
Table 47: 3-bit LUT7 Truth Table	79
Table 48: 3-bit LUT8 Truth Table	79
Table 49: 3-bit LUT9 Truth Table	79
Table 50: 3-bit LUT10 Truth Table	79
Table 51: 3-bit LUT11 Truth Table	79
Table 52: 3-bit LUT12 Truth Table	79
Table 53: 4-bit LUT1 Truth Table	83
Table 54: 4-bit LUT Standard Digital Functions	83
Table 55: Op Amp Bandwidth Settings	106
Table 56: Analog Switch 0 Modes of Operation.....	158
Table 57: Analog Switch 1 Modes of Operation	159
Table 58: Vref Selection Table	183
Table 59: Oscillator Operation Mode Configuration Settings	196
Table 60: RPR Format	220
Table 61: RPR Bit Function Description.....	220

SLG47004

GreenPAK Programmable Mixed-Signal Matrix with In-System Programmability and Advanced Analog Features

Table 62: NPR Format	221
Table 63: NPR Bit Function Description	221
Table 64: Read/Write Register Protection Options	221
Table 65: Erase Register Bit Format	228
Table 66: Erase Register Bit Function Description	229
Table 67: Write/Erase Protect Register Format	230
Table 68: Write/Erase Protect Register Bit Function Description	230
Table 69: Register Map	234

SLG47004

GreenPAK Programmable Mixed-Signal Matrix
with In-System Programmability and Advanced Analog Features

1 Block Diagram

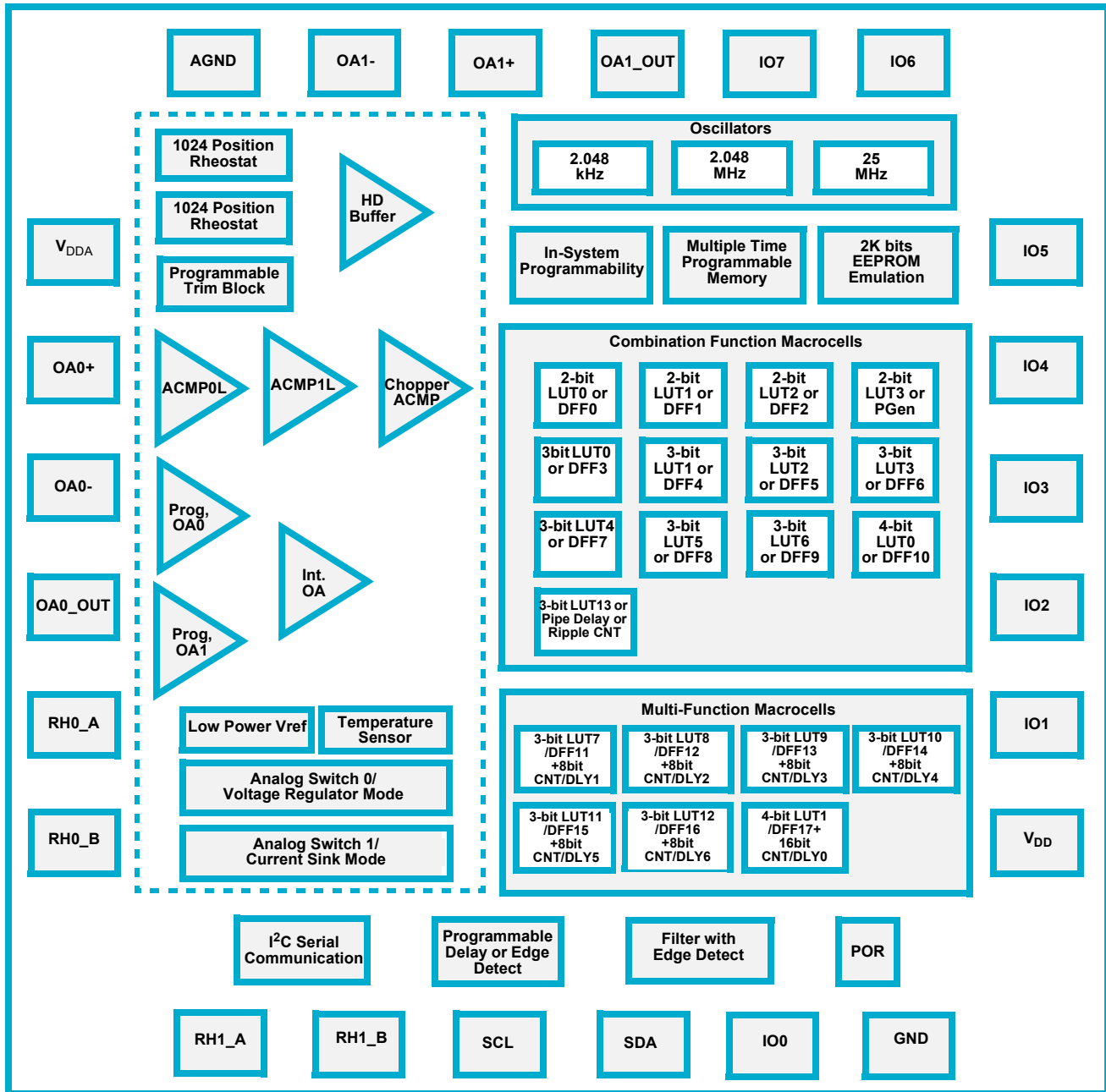

Figure 1: Block Diagram

SLG47004

GreenPAK Programmable Mixed-Signal Matrix with In-System Programmability and Advanced Analog Features

2 Pinout

2.1 PIN CONFIGURATION - STQFN-24L

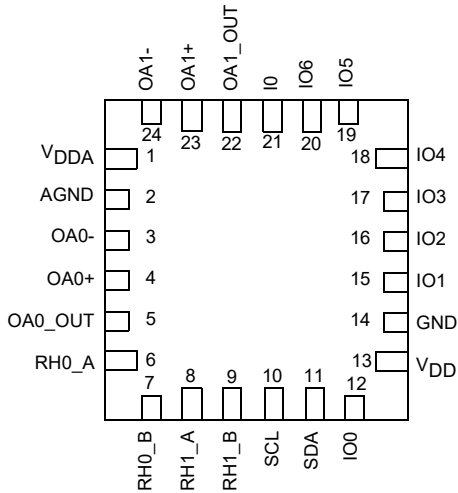

**STQFN-24
(Top View)**

Pin #	Signal Name	Pin Functions
1	V _{DDA}	Analog Power Supply
2	AGND	Analog Ground
3	OA0-	Op Amp0 Inverting Input
4	OA0+	Op Amp0 Non-Inverting Input
5	OA0_OUT	Op Amp0_OUT/ACMP0L+ /
6	RH0_A	Digital Rheostat 0 Terminal A
7	RH0_B	Digital Rheostat 0 Terminal B
8	RH1_A	Digital Rheostat 1 Terminal A
9	RH1_B	Digital Rheostat 1 Terminal B
10	SCL	I ² C_SCL
11	SDA	I ² C_SDA
12	IO0	GPIO, ACMP0L-, ACMP1L-, EXT_OSC0_IN, Vref0_Out or Temp_Sens_Out
13	V _{DD}	Digital Power Supply
14	GND	Digital Ground
15	IO1	GPIO, Chop_ACMP+, Vref1_OUT or Temp_Sens_Out, EXT_OSC1_IN or SLA_0
16	IO2	GPIO, ACMP0L+, EXT_OSC2_IN, SLA_1
17	IO3	GPIO, AS_1_A, ACMP1L+ or SLA_2
18	IO4	GPIO, AS_1_B, Chop_ACMP- or SLA_3
19	IO5	GPIO, AS_0_B
20	IO6	GPIO, AS_0_A, HD_Buff_Out, In Amp_Vref
21	IO0	GPI, In Amp_OUT
22	OA1_OUT	Op Amp1_OUT, ACMP1L+
23	OA1+	Op Amp1 Non-inverting Input
24	OA1-	Op Amp1 Inverting Input

Legend:

- ACMPx+:** ACMPx Positive Input
- ACMPx-:** ACMPx Negative Input
- SCL:** I²C Clock Input
- SDA:** I²C Data Input/Output
- Vrefx:** Voltage Reference Output
- SLA:** Slave Address

Table 1: Functional Pin Description

Pin No.	Pin Name	Signal Name	Function	Input Options	Output Options
1	V _{DDA}	V _{DDA}	Analog Power Supply	--	--
2	AGND	AGND	Analog Ground	--	--
3	OA0-	OA0-	Op Amp0 Inverting Input	Analog	--
4	OA0+	OA0+	Op Amp0 Non-Inverting Input	Analog	--
5	OA0_OUT	OA0_OUT	Op Amp0 Output	--	Analog
		ACMP0L+	Analog Comparator 0 Positive Input	Analog	--
6	RH0_A	RH0_A	Digital Rheostat 0 Terminal A	--	--

SLG47004

GreenPAK Programmable Mixed-Signal Matrix with In-System Programmability and Advanced Analog Features

Table 1: Functional Pin Description(Continued)

Pin No.	Pin Name	Signal Name	Function	Input Options	Output Options
STQFN 24L					
7	RH0_B	RH0_B	Digital Rheostat 0 Terminal B	--	--
8	RH1_A	RH1_A	Digital Rheostat 1 Terminal A	--	--
9	RH1_B	RH1_B	Digital Rheostat 1 Terminal B	--	--
10	SCL	SCL	I ² C Serial Clock	--	--
11	SDA	SDA	I ² C Serial Data	--	--
12	IO0	IO0	General Purpose IO	--	--
		ACMP0L-	Analog Comparator 0 Negative Input	Analog	--
		ACMP1L-	Analog Comparator 1 Negative Input	Analog	--
		EXT_OSC0_IN	External Clock Connection	--	--
		Vref0_Out	Voltage Reference 0 Output	--	Analog
13	V _{DD}	V _{DD}	Digital Power Supply	--	--
14	GND	GND	Digital Ground	--	--
15	IO1	IO1	General Purpose IO	--	--
		CHOP_ACMP+	Chopper ACMP Positive Input	Analog	--
		Temp_Sens_Out	Temperature Sensor Output	--	Analog
		EXT_OSC1_IN	External Clock Connection	--	--
		SLA_0	Slave Address 0	--	--
16	IO2	IO2	General Purpose IO	--	--
		ACMP0L+	Analog Comparator 0 Positive Input	Analog	--
		EXT_OSC2_IN	External Clock Connection	--	--
		SLA_1	Slave Address 1	--	--
17	IO3	IO3	General Purpose IO	--	--
		AS_1_A	Analog Switch 1 Input A	Analog	Analog
		ACMP1L+	Analog Comparator 1 Positive Input	--	--
		SLA_2	Slave Address 2	--	--
18	IO4	IO4	General Purpose IO	--	--
		AS_1_B	Analog Switch 1 Input B	Analog	Analog
			Chopper ACMP Negative Input	Analog	--
		SLA_3	Slave Address 3	--	--

SLG47004

GreenPAK Programmable Mixed-Signal Matrix with In-System Programmability and Advanced Analog Features

Table 1: Functional Pin Description(Continued)

Pin No.	Pin Name	Signal Name	Function	Input Options	Output Options
STQFN 24L					
19	IO5	IO5	General Purpose IO	--	--
		AS_0_B	Analog Switch 0 Input B	Analog	Analog
20	IO6	IO6	General Purpose IO	--	--
		AS_0_A	Analog Switch 0 Input A	Analog	Analog
		HD_Buffer_Out	High Drive Buffer Out put	--	Analog
		In Amp_Vref	Instrumentation Amplifier Voltage Reference	Analog	--
21	IO	IO	General Purpose Input	--	--
		In Amp Out	Instrumentation Amplifier Output	Analog	--
22	OA1_OUT	OA1_OUT	Op Amp1 Output	--	Analog
		ACMP1L+	Analog Comparator 1 Positive Input	Analog	--
23	OA1+	OA1+	Op Amp1 Non-inverting Input	Analog	--
24	OA1-	OA1-	Op Amp1 Inverting Input	Analog	--

Table 2: Pin Type Definitions

Pin Type	Description
V _{DDA}	Analog Power Supply
AGND	Analog Ground
OA-	Op Amp Inverting Input
OA+	Op Amp Non-Inverting Input
OA_OUT	Op Amp Output
RH_A	Digital Rheostat Terminal A
RH_B	Digital Rheostat Terminal B
SCL	I ² C Serial Clock
SDA	I ² C Serial Data
IO	General Purpose Input/Output
V _{DD}	Digital Power Supply
GND	Digital Ground
I	General Purpose Input

SLG47004

GreenPAK Programmable Mixed-Signal Matrix with In-System Programmability and Advanced Analog Features

3 Characteristics

3.1 ABSOLUTE MAXIMUM RATINGS

Stresses beyond those listed under Absolute Maximum Ratings may cause permanent damage to the device. These are stress ratings only, so functional operation of the device at these or any other conditions beyond those indicated in the operational sections of the specification are not implied. Exposure to Absolute Maximum Rating conditions for extended periods may affect device reliability.

Analog and digital grounds must be connected together on the PCB board. The place of connection depends on users schematic. For application cases with low digital current of SLG47004, both AGND and GND should be connected to analog ground plane.

Table 3: Absolute Maximum Ratings

Parameter	Min	Max	Unit	
V_{DD} to GND, V_{DDA} to AGND (Note 1)	-0.3	7	V	
Maximum Slew Rate of V_{DDA}	--	2	V/ μ s	
Voltage at Input Pin	GND-0.3	$V_{DD}+0.3$	V	
Current at Input Pin	-1.0	1.0	mA	
Maximum Average or DC Current through V_{DDA} or AGND Pin (Per chip side)	$T_J = 85^\circ\text{C}$	--	110	mA
	$T_J = 110^\circ\text{C}$	--	50	mA
Maximum Average or DC Current through V_{DD} or GND Pin (Per chip side)	$T_J = 85^\circ\text{C}$	--	100	mA
	$T_J = 110^\circ\text{C}$	--	50	mA
Input leakage (Absolute Value)	--	1000	nA	
Storage Temperature Range	-65	150	$^\circ\text{C}$	
Junction Temperature	--	150	$^\circ\text{C}$	
Thermal Resistance (Note 2)	--	132	$^\circ\text{C}/\text{W}$	
Moisture Sensitivity Level		1		

Note 1 V_{DDA} must be equal to V_{DD}
Note 2 Measurements based on Analog Switches

3.2 ELECTROSTATIC DISCHARGE RATINGS

Table 4: Electrostatic Discharge Ratings

Parameter	Min	Max	Unit
ESD Protection (Human Body Model)	2000	--	V
ESD Protection (Charged Device Model)	1300	--	V

3.3 RECOMMENDED OPERATING CONDITIONS

Table 5: Recommended Operating Conditions

Parameter	Condition	Min	Max	Unit
Supply Voltage (V_{DDA})		2.4	5.5	V
	During NVM Write and Erase commands	2.5	5.5	V
Operating Temperature		-40	85	$^\circ\text{C}$
Capacitor Value at V_{DD}		0.1	--	μF
Analog Input Common Mode Range	Allowable Input Voltage at Analog Pins	-0.2	$V_{DDA}+0.2$	V

SLG47004

GreenPAK Programmable Mixed-Signal Matrix with In-System Programmability and Advanced Analog Features

3.4 ELECTRICAL CHARACTERISTICS

Table 6: EC at T = -40 °C to +85 °C, V_{DD} = 2.4 V to 5.5 V Unless Otherwise Noted

Parameter	Description	Condition	Min	Typ	Max	Unit
V _{IH}	HIGH-Level Input Voltage	Logic Input (Note 1)	0.7x V _{DD}	--	V _{DD} + 0.3	V
		Logic Input with Schmitt Trigger	0.8x V _{DD}	--	V _{DD} + 0.3	V
		Low-Level Logic Input (Note 1)	1.25	--	V _{DD} + 0.3	V
V _{IL}	LOW-Level Input Voltage	Logic Input (Note 1)	GND- 0.3	--	0.3x V _{DD}	V
		Logic Input with Schmitt Trigger	GND- 0.3	--	0.2x V _{DD}	V
		Low-Level Logic Input (Note 1)	GND- 0.3	--	0.5	V
V _{HYS}	Schmitt Trigger Hysteresis Voltage	V _{DD} = 2.5 V +/- 8 %	0.30	0.43	0.58	V
		V _{DD} = 3.3 V +/- 10 %	0.34	0.46	0.60	V
		V _{DD} = 5 V +/- 10 %	0.45	0.58	0.77	V
V _O	Maximal Voltage Applied to any PIN in High Impedance State		--	--	V _{DD} + 0.3	V
V _{OH}	HIGH-Level Output Voltage	Push-Pull, 1x Drive, I _{OH} = 1 mA, V _{DD} = 2.4 V (Note 1)	2.282	--	--	V
		Push-Pull, 1x Drive, I _{OH} = 1 mA, V _{DD} = 2.5 V (Note 1)	2.387	--	--	V
		Push-Pull, 1x Drive, I _{OH} = 1 mA, V _{DD} = 2.7 V (Note 1)	2.597	--	--	V
		Push-Pull, 1x Drive, I _{OH} = 3 mA, V _{DD} = 3.0 V (Note 1)	2.709	--	--	V
		Push-Pull, 1x Drive, I _{OH} = 3 mA, V _{DD} = 3.3 V (Note 1)	3.037	--	--	V
		Push-Pull, 1x Drive, I _{OH} = 3 mA, V _{DD} = 3.6 V (Note 1)	3.359	--	--	V
		Push-Pull, 1x Drive, I _{OH} = 5 mA, V _{DD} = 4.5 V (Note 1)	4.161	--	--	V
		Push-Pull, 1x Drive, I _{OH} = 5 mA, V _{DD} = 5.0 V (Note 1)	4.687	--	--	V
		Push-Pull, 1x Drive, I _{OH} = 5 mA, V _{DD} = 5.5 V (Note 1)	5.213	--	--	V
		Push-Pull, 2x Drive, I _{OH} = 1 mA, V _{DD} = 2.4 V (Note 1)	2.342	--	--	V
		Push-Pull, 2x Drive, I _{OH} = 1 mA, V _{DD} = 2.5 V (Note 1)	2.445	--	--	V
		Push-Pull, 2x Drive, I _{OH} = 1 mA, V _{DD} = 2.7 V (Note 1)	2.649	--	--	V
		Push-Pull, 2x Drive, I _{OH} = 3 mA, V _{DD} = 3.0 V (Note 1)	2.859	--	--	V
		Push-Pull, 2x Drive, I _{OH} = 3 mA, V _{DD} = 3.3 V (Note 1)	3.171	--	--	V
		Push-Pull, 2x Drive, I _{OH} = 3 mA, V _{DD} = 3.6 V (Note 1)	3.481	--	--	V

SLG47004

GreenPAK Programmable Mixed-Signal Matrix with In-System Programmability and Advanced Analog Features

Table 6: EC at T = -40 °C to +85 °C, V_{DD} = 2.4 V to 5.5 V Unless Otherwise Noted(Continued)

Parameter	Description	Condition	Min	Typ	Max	Unit
V _{OH}	HIGH-Level Output Voltage	Push-Pull, 2x Drive, I _{OH} = 5 mA, V _{DD} = 4.5 V (Note 1)	4.333	--	--	V
		Push-Pull, 2x Drive, I _{OH} = 5 mA, V _{DD} = 5.0 V (Note 1)	4.845	--	--	V
		Push-Pull, 2x Drive, I _{OH} = 5 mA, V _{DD} = 5.5 V (Note 1)	5.356	--	--	V
V _{OL}	LOW-Level Output Voltage	Push-Pull, 1x Drive, I _{OL} = 1 mA, V _{DD} = 2.4 V (Note 1)	--	--	0.085	V
		Push-Pull, 1x Drive, I _{OL} = 1 mA, V _{DD} = 2.5 V (Note 1)	--	--	0.082	V
		Push-Pull, 1x Drive, I _{OL} = 1 mA, V _{DD} = 2.7 V (Note 1)	--	--	0.077	V
		Push-Pull, 1x Drive, I _{OL} = 3 mA, V _{DD} = 3.0 V (Note 1)	--	--	0.218	V
		Push-Pull, 1x Drive, I _{OL} = 3 mA, V _{DD} = 3.3 V (Note 1)	--	--	0.202	V
		Push-Pull, 1x Drive, I _{OL} = 3 mA, V _{DD} = 3.6 V (Note 1)	--	--	0.190	V
		Push-Pull, 1x Drive, I _{OL} = 5 mA, V _{DD} = 4.5 V (Note 1)	--	--	0.277	V
		Push-Pull, 1x Drive, I _{OL} = 5 mA, V _{DD} = 5.0 V (Note 1)	--	--	0.260	V
		Push-Pull, 1x Drive, I _{OL} = 5 mA, V _{DD} = 5.5 V (Note 1)	--	--	0.245	V
		Push-Pull, 2x Drive, I _{OL} = 1 mA, V _{DD} = 2.4 V (Note 1)	--	--	0.043	V
		Push-Pull, 2x Drive, I _{OL} = 1 mA, V _{DD} = 2.5 V (Note 1)	--	--	0.042	V
		Push-Pull, 2x Drive, I _{OL} = 1 mA, V _{DD} = 2.7 V (Note 1)	--	--	0.039	V
		Push-Pull, 2x Drive, I _{OL} = 3 mA, V _{DD} = 3.0 V (Note 1)	--	--	0.109	V
		Push-Pull, 2x Drive, I _{OL} = 3 mA, V _{DD} = 3.3 V (Note 1)	--	--	0.102	V
		Push-Pull, 2x Drive, I _{OL} = 3 mA, V _{DD} = 3.6 V (Note 1)	--	--	0.096	V
		Push-Pull, 2x Drive, I _{OL} = 5 mA, V _{DD} = 4.5 V (Note 1)	--	--	0.143	V
		Push-Pull, 2x Drive, I _{OL} = 5 mA, V _{DD} = 5.0 V (Note 1)	--	--	0.136	V
		Push-Pull, 2x Drive, I _{OL} = 5 mA, V _{DD} = 5.5 V (Note 1)	--	--	0.127	V
		NMOS OD, 1x Drive, I _{OL} = 1 mA, V _{DD} = 2.4 V (Note 1)	--	--	0.035	V
		NMOS OD, 1x Drive, I _{OL} = 1 mA, V _{DD} = 2.5 V (Note 1)	--	--	0.034	V
		NMOS OD, 1x Drive, I _{OL} = 1 mA, V _{DD} = 2.7 V (Note 1)	--	--	0.032	V
NMOS OD, 1x Drive, I _{OL} = 3 mA, V _{DD} = 3.0 V (Note 1)	--	--	0.088	V		

SLG47004

GreenPAK Programmable Mixed-Signal Matrix with In-System Programmability and Advanced Analog Features

Table 6: EC at T = -40 °C to +85 °C, V_{DD} = 2.4 V to 5.5 V Unless Otherwise Noted(Continued)

Parameter	Description	Condition	Min	Typ	Max	Unit
V _{OL}	LOW-Level Output Voltage	NMOS OD, 1x Drive, I _{OL} = 3 mA, V _{DD} = 3.3 V (Note 1)	--	--	0.082	V
		NMOS OD, 1x Drive, I _{OL} = 3 mA, V _{DD} = 3.6 V (Note 1)	--	--	0.078	V
		NMOS OD, 1x Drive, I _{OL} = 5 mA, V _{DD} = 4.5 V (Note 1)	--	--	0.114	V
		NMOS OD, 1x Drive, I _{OL} = 5 mA, V _{DD} = 5.0 V (Note 1)	--	--	0.108	V
		NMOS OD, 1x Drive, I _{OL} = 5 mA, V _{DD} = 5.5 V (Note 1)	--	--	0.103	V
		NMOS OD, 2x Drive, I _{OL} = 1 mA, V _{DD} = 2.4 V (Note 1)	--	--	0.019	V
		NMOS OD, 2x Drive, I _{OL} = 1 mA, V _{DD} = 2.5 V (Note 1)	--	--	0.019	V
		NMOS OD, 2x Drive, I _{OL} = 1 mA, V _{DD} = 2.7 V (Note 1)	--	--	0.018	V
		NMOS OD, 2x Drive, I _{OL} = 3 mA, V _{DD} = 3.0 V (Note 1)	--	--	0.047	V
		NMOS OD, 2x Drive, I _{OL} = 3 mA, V _{DD} = 3.3 V (Note 1)	--	--	0.044	V
		NMOS OD, 2x Drive, I _{OL} = 3 mA, V _{DD} = 3.6 V (Note 1)	--	--	0.042	V
		NMOS OD, 2x Drive, I _{OL} = 5 mA, V _{DD} = 4.5 V (Note 1)	--	--	0.063	V
		NMOS OD, 2x Drive, I _{OL} = 5 mA, V _{DD} = 5.0 V (Note 1)	--	--	0.060	V
		NMOS OD, 2x Drive, I _{OL} = 5 mA, V _{DD} = 5.5 V (Note 1)	--	--	0.057	V
I _{OH}	HIGH-Level Output Current (Note 2)	Push-Pull, 1x Drive, V _{OH} = V _{DD} - 0.2 V _{DD} = 2.4 V (Note 1)	1.63	--	--	mA
		Push-Pull, 1x Drive, V _{OH} = V _{DD} - 0.2 V _{DD} = 2.5 V (Note 1)	1.72	--	--	mA
		Push-Pull, 1x Drive, V _{OH} = V _{DD} - 0.2 V _{DD} = 2.7 V (Note 1)	1.88	--	--	mA
		Push-Pull, 1x Drive, V _{OH} = 2.4 V, V _{DD} = 3.0 V (Note 1)	5.48	--	--	mA
		Push-Pull, 1x Drive, V _{OH} = 2.4 V, V _{DD} = 3.3 V (Note 1)	8.31	--	--	mA
		Push-Pull, 1x Drive, V _{OH} = 2.4 V, V _{DD} = 3.6 V (Note 1)	11.11	--	--	mA
		Push-Pull, 1x Drive, V _{OH} = 2.4 V, V _{DD} = 4.5 V (Note 1)	19.61	--	--	mA
		Push-Pull, 1x Drive, V _{OH} = 2.4 V, V _{DD} = 5.0 V (Note 1)	24.00	--	--	mA
		Push-Pull, 1x Drive, V _{OH} = 2.4 V, V _{DD} = 5.5 V (Note 1)	29.24	--	--	mA
		Push-Pull, 2x Drive, V _{OH} = V _{DD} - 0.2 V _{DD} = 2.4 V (Note 1)	3.25	--	--	mA
		Push-Pull, 2x Drive, V _{OH} = V _{DD} - 0.2 V _{DD} = 2.5 V (Note 1)	3.42	--	--	mA

SLG47004

GreenPAK Programmable Mixed-Signal Matrix with In-System Programmability and Advanced Analog Features

Table 6: EC at T = -40 °C to +85 °C, V_{DD} = 2.4 V to 5.5 V Unless Otherwise Noted(Continued)

Parameter	Description	Condition	Min	Typ	Max	Unit
I _{OH}	HIGH-Level Output Current (Note 2)	Push-Pull, 2x Drive, V _{OH} = V _{DD} - 0.2 V, V _{DD} = 2.7 V (Note 1)	3.73	--	--	mA
		Push-Pull, 2x Drive, V _{OH} = 2.4 V, V _{DD} = 3.0 V (Note 1)	10.84	--	--	mA
		Push-Pull, 2x Drive, V _{OH} = 2.4 V, V _{DD} = 3.3 V (Note 1)	16.34	--	--	mA
		Push-Pull, 2x Drive, V _{OH} = 2.4 V, V _{DD} = 3.6 V (Note 1)	21.83	--	--	mA
		Push-Pull, 2x Drive, V _{OH} = 2.4 V, V _{DD} = 4.5 V (Note 1)	38.34	--	--	mA
		Push-Pull, 2x Drive, V _{OH} = 2.4 V, V _{DD} = 5.0 V (Note 1)	47.07	--	--	mA
		Push-Pull, 2x Drive, V _{OH} = 2.4 V, V _{DD} = 5.5 V (Note 1)	56.68	--	--	mA
I _{OL}	LOW-Level Output Current (Note 2)	Push-Pull, 1x Drive, V _{OL} = 0.15 V, V _{DD} = 2.4 V (Note 1)	1.67	--	--	mA
		Push-Pull, 1x Drive, V _{OL} = 0.15 V, V _{DD} = 2.5 V (Note 1)	1.74	--	--	mA
		Push-Pull, 1x Drive, V _{OL} = 0.15 V, V _{DD} = 2.7 V (Note 1)	1.85	--	--	mA
		Push-Pull, 1x Drive, V _{OL} = 0.4 V, V _{DD} = 3.0 V (Note 1)	5.07	--	--	mA
		Push-Pull, 1x Drive, V _{OL} = 0.4 V, V _{DD} = 3.3 V (Note 1)	5.48	--	--	mA
		Push-Pull, 1x Drive, V _{OL} = 0.4 V, V _{DD} = 3.6 V (Note 1)	5.85	--	--	mA
		Push-Pull, 1x Drive, V _{OL} = 0.4 V, V _{DD} = 4.5 V (Note 1)	6.81	--	--	mA
		Push-Pull, 1x Drive, V _{OL} = 0.4 V, V _{DD} = 5.0 V (Note 1)	7.27	--	--	mA
		Push-Pull, 1x Drive, V _{OL} = 0.4 V, V _{DD} = 5.5 V (Note 1)	7.72	--	--	mA
		Push-Pull, 2x Drive, V _{OL} = 0.15 V, V _{DD} = 2.4 V (Note 1)	3.27	--	--	mA
		Push-Pull, 2x Drive, V _{OL} = 0.15 V, V _{DD} = 2.5 V (Note 1)	3.39	--	--	mA
		Push-Pull, 2x Drive, V _{OL} = 0.15 V, V _{DD} = 2.7 V (Note 1)	3.61	--	--	mA
		Push-Pull, 2x Drive, V _{OL} = 0.4 V, V _{DD} = 3.0 (Note 1)	9.85	--	--	mA
		Push-Pull, 2x Drive, V _{OL} = 0.4 V, V _{DD} = 3.3 (Note 1)	10.63	--	--	mA
		Push-Pull, 2x Drive, V _{OL} = 0.4 V, V _{DD} = 3.6 (Note 1)	11.33	--	--	mA
		Push-Pull, 2x Drive, V _{OL} = 0.4 V, V _{DD} = 4.5 (Note 1)	13.06	--	--	mA
		Push-Pull, 2x Drive, V _{OL} = 0.4 V, V _{DD} = 5.0 (Note 1)	13.79	--	--	mA

SLG47004

GreenPAK Programmable Mixed-Signal Matrix with In-System Programmability and Advanced Analog Features

Table 6: EC at T = -40 °C to +85 °C, V_{DD} = 2.4 V to 5.5 V Unless Otherwise Noted(Continued)

Parameter	Description	Condition	Min	Typ	Max	Unit
I _{OL}	LOW-Level Output Current (Note 2)	Push-Pull, 2x Drive, V _{OL} = 0.4 V, V _{DD} = 5.5 V (Note 1)	14.80	--	--	mA
		NMOS OD, 1x Drive, V _{OL} = 0.15 V, V _{DD} = 2.4 V (Note 1)	4.07	--	--	mA
		NMOS OD, 1x Drive, V _{OL} = 0.15 V, V _{DD} = 2.5 V (Note 1)	4.22	--	--	mA
		NMOS OD, 1x Drive, V _{OL} = 0.15 V, V _{DD} = 2.7 V (Note 1)	4.49	--	--	mA
		NMOS OD, 1x Drive, V _{OL} = 0.4 V, V _{DD} = 3.0 V (Note 1)	12.24	--	--	mA
		NMOS OD, 1x Drive, V _{OL} = 0.4 V, V _{DD} = 3.3 V (Note 1)	13.20	--	--	mA
		NMOS OD, 1x Drive, V _{OL} = 0.4 V, V _{DD} = 3.6 V (Note 1)	14.04	--	--	mA
		NMOS OD, 1x Drive, V _{OL} = 0.4 V, V _{DD} = 4.5 V (Note 1)	16.24	--	--	mA
		NMOS OD, 1x Drive, V _{OL} = 0.4 V, V _{DD} = 5.0 V (Note 1)	17.24	--	--	mA
		NMOS OD, 1x Drive, V _{OL} = 0.4 V, V _{DD} = 5.5 V (Note 1)	18.24	--	--	mA
		NMOS OD, 2x Drive, V _{OL} = 0.15 V, V _{DD} = 2.4 V (Note 1)	7.71	--	--	mA
		NMOS OD, 2x Drive, V _{OL} = 0.15 V, V _{DD} = 2.5 V (Note 1)	7.97	--	--	mA
		NMOS OD, 2x Drive, V _{OL} = 0.15 V, V _{DD} = 2.7 V (Note 1)	8.46	--	--	mA
		NMOS OD, 2x Drive, V _{OL} = 0.4 V, V _{DD} = 3.0 V (Note 1)	22.96	--	--	mA
		NMOS OD, 2x Drive, V _{OL} = 0.4 V, V _{DD} = 3.3 V (Note 1)	24.63	--	--	mA
		NMOS OD, 2x Drive, V _{OL} = 0.4 V, V _{DD} = 3.6 V (Note 1)	26.10	--	--	mA
		NMOS OD, 2x Drive, V _{OL} = 0.4 V, V _{DD} = 4.5 V (Note 1)	29.82	--	--	mA
		NMOS OD, 2x Drive, V _{OL} = 0.4 V, V _{DD} = 5.0 V (Note 1)	31.42	--	--	mA
		NMOS OD, 2x Drive, V _{OL} = 0.4 V, V _{DD} = 5.5 V (Note 1)	33.25	--	--	mA
		T _{SU}	Startup Time	From V _{DD} rising past PON _{THR}	--	1.9
T _{WR}	NVM Page Write Time	V _{DD} = 2.5 V to 5.5 V	--	--	20	ms
T _{ER}	NVM Page Erase Time	V _{DD} = 2.5 V to 5.5 V	--	--	20	ms
PON _{THR}	Power-On Threshold	V _{DD} Level Required to Start Up the Chip	1.63	--	2.04	V
POFF _{THR}	Power-Off Threshold	V _{DD} Level Required to Switch Off the Chip	0.96	--	1.54	V

SLG47004

GreenPAK Programmable Mixed-Signal Matrix with In-System Programmability and Advanced Analog Features

Table 6: EC at T = -40 °C to +85 °C, V_{DD} = 2.4 V to 5.5 V Unless Otherwise Noted(Continued)

Parameter	Description	Condition	Min	Typ	Max	Unit
R _{PULL}	Pull-up or Pull-down Resistance	1 M for Pull-up: V _{IN} = GND; for Pull-down: V _{IN} = V _{DD} (Note 1)	--	1	--	MΩ
		100 k for Pull-up: V _{IN} = GND; for Pull-down: V _{IN} = V _{DD} (Note 1)	--	100	--	kΩ
		10 k For Pull-up: V _{IN} = GND; for Pull-down: V _{IN} = V _{DD} (Note 1)	--	9.3	--	kΩ
C _{IN}	Input Capacitance	PINs 10, 11	--	2.9	--	pF
		PIN 12	--	3.6	--	pF
		PINs 15, 16	--	3.8	--	pF
		PINs 17, 18, 19	--	10.2	--	pF
		PIN 20	--	27.8	--	pF
		PIN 21	--	5.7	--	pF

Note 1 No hysteresis.

Note 2 DC or average current through any pin should not exceed value given in Absolute Maximum Conditions.

3.5 I²C PINS CHARACTERISTICS

Table 7: EC of the I²C Pins for DI at T = -40 °C to +85 °C, V_{DD} = 2.4 V to 5.5 V Unless Otherwise Noted

Parameter	Description	Condition	Fast-Mode		Fast-Mode Plus		Unit
			Min	Max	Min	Max	
V _{IL}	LOW-level Input Voltage		-0.5	0.3xV _{DD}	-0.5	0.3xV _{DD}	V
V _{IH}	HIGH-level Input Voltage		0.7xV _{DD}	5.5	0.7xV _{DD}	5.5	V
V _{HYS}	Hysteresis of Schmitt Trigger Inputs		0.05xV _{DD}	--	0.05xV _{DD}	--	V
V _{OL1}	LOW-Level Output Voltage 1	(Open-Drain) at 3 mA sink current V _{DD} > 2 V	0	0.4	0	0.4	V
V _{OL2}	LOW-Level Output Voltage 2	(Open-Drain) at 2 mA sink current V _{DD} ≤ 2 V	0	0.2xV _{DD}	0	0.2xV _{DD}	V
I _{OL}	LOW-Level Output Current (Note 1)	V _{OL} = 0.4 V, V _{DD} = 2.4 V	3	--	16.75	--	mA
		V _{OL} = 0.4 V, V _{DD} = 3.0 V	3	--	20	--	mA
		V _{OL} = 0.4 V, V _{DD} = 4.5 V	3	--	20	--	mA
		V _{OL} = 0.6 V	6	--	--	--	mA
t _{OF}	Output Fall Time from V _{IHmin} to V _{ILmax} (Note 1)		14x (V _{DD} /5.5 V)	250	10x (V _{DD} /5.5 V)	120	ns
t _{SP}	Pulse Width of Spikes that must be suppressed by the Input Filter		0	50	0	50	ns
I _i	Input Current (each IO Pin)	0.1xV _{DD} < V _I < 0.9xV _{DDmax}	-10	+10	-10	+10	μA
C _i	Capacitance (each IO Pin)		--	10	--	10	pF

SLG47004

GreenPAK Programmable Mixed-Signal Matrix with In-System Programmability and Advanced Analog Features

Table 7: EC of the I²C Pins for DI at T = -40 °C to +85 °C, V_{DD} = 2.4 V to 5.5 V Unless Otherwise Noted(Continued)

Parameter	Description	Condition	Fast-Mode		Fast-Mode Plus		Unit
			Min	Max	Min	Max	
Note 1 Does not meet standard I ² C specifications: t _{OF} = 20x(V _{DD} /5.5 V) (min); For Fast-mode Plus I _{OL} = 20 mA (min) at V _{OL} = 0.4 V. Note 2 For Fast-mode Plus SDA pin must be configured as NMOS 2x Open-Drain, see register [1155] in Section 21.							

Table 8: EC of the I²C Pins for DILV at T = -40 °C to +85 °C, V_{DD} = 2.4 V to 5.5 V Unless Otherwise Noted

Parameter	Description	Condition	Fast-Mode		Unit
			Min	Max	
V _{IL}	LOW-level Input Voltage		-0.5	0.3xV _{DD}	V
V _{IH}	HIGH-level Input Voltage		0.7xV _{DD}	5.5	V
V _{HYS}	Hysteresis of Schmitt Trigger Inputs		0.05xV _{DD}	--	V
V _{OL1}	LOW-Level Output Voltage 1	(Open-Drain) at 3 mA sink current V _{DD} > 2 V	0	0.4	V
V _{OL2}	LOW-Level Output Voltage 2	(Open-Drain) at 2 mA sink current V _{DD} ≤ 2 V	0	0.2xV _{DD}	V
I _{OL}	LOW-Level Output Current (Note 1)	V _{OL} = 0.4 V, V _{DD} = 2.4 V	3	--	mA
		V _{OL} = 0.4 V, V _{DD} = 3.0 V	3	--	mA
		V _{OL} = 0.4 V, V _{DD} = 4.5 V	3	--	mA
		V _{OL} = 0.6 V	6	--	mA
t _{OF}	Output Fall Time from V _{IHmin} to V _{ILmax} (Note 1)		14x (V _{DD} /5.5 V)	250	ns
t _{SP}	Pulse Width of Spikes that must be suppressed by the Input Filter		0	50	ns
I _i	Input Current (each IO Pin)	0.1xV _{DD} < V _I < 0.9xV _{DDmax}	-10	+10	μA
C _i	Capacitance (each IO Pin)		--	10	pF
Note 1 Does not meet standard I ² C specifications: t _{OF} = 20x(V _{DD} /5.5 V) (min); For Fast-mode Plus I _{OL} = 20 mA (min) at V _{OL} = 0.4 V. Note 2 For Fast-mode Plus SDA pin must be configured as NMOS 2x Open-Drain, see register [1155] in Section 21.					

Table 9: I²C Pins Timing Characteristics at T = -40 °C to +85 °C, V_{DD} = 2.4 V to 5.5 V Unless Otherwise Noted

Parameter	Description	Condition	Fast-Mode		Fast-Mode Plus		Unit
			Min	Max	Min	Max	
f _{SCL}	SCL Clock Frequency		--	400	--	1000	kHz
t _{LOW}	SCL Clock, Low Period		1300	--	500	--	ns
t _{HIGH}	SCL Clock, High Period		600	--	260	--	ns
t _{VD_DAT}	Data Valid Time		--	900	--	450	ns
t _{VD_ACK}	Data Valid Acknowledge Time		--	900	--	450	ns
t _{BUF}	Bus Free Time between STOP and START Conditions		1300	--	500	--	ns

SLG47004

GreenPAK Programmable Mixed-Signal Matrix with In-System Programmability and Advanced Analog Features

Table 9: I²C Pins Timing Characteristics at T = -40 °C to +85 °C, V_{DD} = 2.4 V to 5.5 V Unless Otherwise Noted

Parameter	Description	Condition	Fast-Mode		Fast-Mode Plus		Unit
			Min	Max	Min	Max	
t _{HD_STA}	Hold Time for Repeated START Condition		600	--	260	--	ns
t _{SU_STA}	Set-Up Time for STOP Condition		600	--	260	--	ns
t _{HD_DAT}	Data Hold Time		0	--	0	--	ns
		Low-voltage Logic Input Mode (Note 1)	185	--	N/A	N/A	ns
t _{SU_DAT}	Data Set-up Time		100	--	50	--	ns
		Low-voltage Logic Input Mode (Note 1)	335	--	N/A	N/A	ns
t _R	SCL, SDA Rise Time		--	300	--	120	ns
t _F	SCL, SDA Fall Time		--	300	--	120	ns
t _{SU_STD}	Set-up Time for STOP Condition		600	--	260	--	ns

Note 1 Does not meet standard I²C specifications.
Note 2 Timing diagram can be found in [Figure 237](#).

3.6 MACROCELLS CURRENT CONSUMPTION

Table 10: Typical Current Estimated for Each Macrocell at T = 25°C

Parameter	Description	Note	V _{DD} = 2.5 V	V _{DD} = 3.3 V	V _{DD} = 5.0 V	Unit
I	Current	Chip Quiescent, BG disabled	0.06	0.08	0.13	μA
		Chip Quiescent, BG enabled	0.36	0.39	0.47	μA
		OSC2 25 MHz, pre-divider = 1	40.78	49.64	70.54	μA
		OSC2 25 MHz, pre-divider = 4	31.75	37.46	51.41	μA
		OSC2 25 MHz, pre-divider = 8	29.96	35.06	47.62	μA
		OSC1 2.048 MHz, pre-divider = 1	19.19	19.98	21.73	μA
		OSC1 2.048 MHz, pre-divider = 4	18.50	19.05	20.26	μA
		OSC1 2.048 MHz, pre-divider = 8	18.36	18.87	19.97	μA
		OS00 2.048 kHz, pre-divider = 1	0.33	0.36	0.44	μA
		OS00 2.048 kHz, pre-divider = 4	0.33	0.36	0.44	μA
		OS00 2.048 kHz, pre-divider = 8	0.33	0.36	0.44	μA
		Push-Pull 1x + 4 pF @ 2.048 kHz	0.38	0.44	0.55	μA
		Push-Pull 1x + 4 pF @ 2.048 MHz	66.8	82.6	116.0	μA
		Temperature Sensor, range 1	10.9	10.9	11.2	μA
		Temperature Sensor, range 2	11.0	11.1	11.4	μA
		One ACMPx_L (includes internal Vref)	6.1	6.2	6.4	μA
		Two ACMPx_L (includes internal Vref)	8.4	8.5	8.8	μA
		Op AmpX Quiescent Current (128 kHz bandwidth)	32.2	32.8	33.8	μA
Op AmpX Quiescent Current (8.192 MHz bandwidth)	607	611	613	μA		
In Amp Quiescent Current (three Op Amps are ON, Rf1 = Rf2 = 50 kΩ, Rg = 1 kΩ, 128 kHz bandwidth, Charge Pump - Disabled)	98	101	104	μA		

SLG47004

GreenPAK Programmable Mixed-Signal Matrix with In-System Programmability and Advanced Analog Features

Table 10: Typical Current Estimated for Each Macrocell at T = 25°C(Continued)

Parameter	Description	Note	V _{DD} = 2.5 V	V _{DD} = 3.3 V	V _{DD} = 5.0 V	Unit
		In Amp Quiescent Current (three Op Amps are ON, Rf1 = Rf2 = 50 kΩ, Rg = 1 kΩ, 128 kHz bandwidth, Charge Pump - Enabled)	75.2	77.5	80.8	μA
		In Amp Quiescent Current (three Op Amps are ON, Rf1 = Rf2 = 50 kΩ, Rg = 1 kΩ, 8.192 MHz bandwidth, Charge Pump - Disabled)	1819	1834	1844	μA
		In Amp Quiescent Current (three Op Amps are ON, Rf1 = Rf2 = 50 kΩ, Rg = 1 kΩ, 8.192 MHz bandwidth, Charge Pump - Enabled)	1225	1235	1245	μA
		Chopper ACMP (with 2.048 kHz clock)	31.4	33.6	38.4	μA

3.7 TIMING CHARACTERISTICS

Table 11: Typical Delay Estimated for Each Macrocell at T = 25 °C

Parameter	Description	Conditions	V _{DD} = 2.5 V		V _{DD} = 3.3 V		V _{DD} = 5.0 V		Unit
			Rising	Falling	Rising	Falling	Rising	Falling	
tpd	Delay	Digital Input to PP 1x	26	27	18	20	13	15	ns
tpd	Delay	Digital Input with Schmitt Trigger to PP 1x	27	28	19	21	15	15	ns
tpd	Delay	Digital Input to PP 2x	24	25	17	18	12	14	ns
tpd	Delay	Low Voltage Digital input to PP 1x	28	246	20	163	15	95	ns
tpd	Delay	Digital input to NMOS output	--	24	--	18	--	13	ns
tpd	Delay	Output enable from Pin, OE Hi-Z to 1	26	--	19	--	13	--	ns
tpd	Delay	Output enable from Pin, OE Hi-Z to 0	--	26	--	19	--	14	ns
tpd	Delay	Digital input to 1x3-State (Z to 1)	26	--	19	--	13	--	ns
tpd	Delay	Digital input to x3-State (Z to 0)	--	26	--	17	--	14	ns
tpd	Delay	Digital input to 2x3-State (Z to 1)	24	--	17	--	13	--	ns
tpd	Delay	Digital input to 2x3-State (Z to 0)	--	24	--	19	--	12	ns
tpd	Delay	2-bit LUT	17	17	12	12	8	8	ns
tpd	Delay	3-bit LUT	19	20	13	14	9	10	ns
tpd	Delay	4-bit LUT	20	21	15	14	9	10	ns
tpd	Delay	LATCH	25	25	17	18	12	12	ns
tpd	Delay	DFF	24	25	16	18	11	12	ns
tpd	Delay	CNT/DLY	107	107	77	74	48	70	ns
tw	Width	Edge detect	206	205	161	160	116	116	ns
tpd	Delay	Edge detect	19	20	13	13	8	8	ns
tpd	Delay	Edge detect Delayed	241	241	175	175	125	125	ns
tpd	Delay	Ripple Counter	45	60	32	44	22	31	ns

SLG47004

GreenPAK Programmable Mixed-Signal Matrix with In-System Programmability and Advanced Analog Features

Table 11: Typical Delay Estimated for Each Macrocell at T = 25 °C(Continued)

Parameter	Description	Conditions	V _{DD} = 2.5 V		V _{DD} = 3.3 V		V _{DD} = 5.0 V		Unit
			Rising	Falling	Rising	Falling	Rising	Falling	
tpd	Delay	PGen	20	20	14	14	9	10	ns
tpd	Delay	Filter	177	177	121	121	77	78	ns
tpd	Delay	Inverter Filter	115	115	83	83	57	57	ns
tpd	Delay	Pipe Delay	36	37	25	26	17	18	ns

Table 12: Programmable Delay Expected Typical Delays and Widths at T = 25 °C

Parameter	Description	Note	V _{DD} = 2.5 V	V _{DD} = 3.3 V	V _{DD} = 5.0 V	Unit
tw	Pulse Width, 1 cell	mode: (any) edge detect, edge detect output	223	163	118	ns
tw	Pulse Width, 2 cell	mode: (any) edge detect, edge detect output	444	324	233	ns
tw	Pulse Width, 3 cell	mode: (any) edge detect, edge detect output	663	484	347	ns
tw	Pulse Width, 4 cell	mode: (any) edge detect, edge detect output	882	643	461	ns
time1	Delay, 1 cell	mode: (any) edge detect, edge detect output	18	12	8	ns
time1	Delay, 2 cell	mode: (any) edge detect, edge detect output	18	12	8	ns
time1	Delay, 3 cell	mode: (any) edge detect, edge detect output	18	12	8	ns
time1	Delay, 4 cell	mode: (any) edge detect, edge detect output	18	12	8	ns
time2	Delay, 1 cell	mode: both edge delay, edge detect output	243	176	126	ns
time2	Delay, 2 cell	mode: both edge delay, edge detect output	464	337	241	ns
time2	Delay, 3 cell	mode: both edge delay, edge detect output	683	497	356	ns
time2	Delay, 4 cell	mode: both edge delay, edge detect output	902	655	470	ns

Table 13: Typical Filter Rejection Pulse Width at T = 25 °C

Parameter	V _{DD} = 2.5 V	V _{DD} = 3.3 V	V _{DD} = 5.0 V	Unit
Filtered Pulse Width	< 131	< 89	< 59	ns

Table 14: Typical Counter/Delay Offset Measurements at T = 25 °C

Parameter	OSC Freq	OSC Power	V _{DD} = 2.5 V	V _{DD} = 3.3 V	V _{DD} = 5.0 V	Unit
Power-On time	25 MHz	auto	0.046	0.032	0.022	μs
Power-On time	2.048 MHz	auto	0.511	0.458	0.414	μs
Power-On time	2.048 kHz	auto	657	563	477	μs
frequency settling time	25 MHz	auto	0.314	0.378	0.455	μs
frequency settling time	2.048 MHz	auto	1.344	1.597	2.063	μs
frequency settling time	2.048 kHz	auto	657	1066	476	μs
variable (CLK period)	25 MHz	forced	0.039 - 0.042	0.040 - 0.041	0.038 - 0.042	μs
variable (CLK period)	2.048 MHz	forced	0.480 - 0.500	0.490 - 0.491	0.480 - 0.495	μs
variable (CLK period)	2.048 kHz	forced	477 - 500	478 - 499	478 - 498	μs
tpd (non-delayed edge)	25 MHz/ 2.048 kHz	either	35	14	10	ns

SLG47004

GreenPAK Programmable Mixed-Signal Matrix with In-System Programmability and Advanced Analog Features

3.8 OSCILLATOR CHARACTERISTICS

Table 15: Oscillators Frequency Limits, $V_{DD} = 2.4\text{ V to }5.5\text{ V}$

OSC	Temperature Range					
	+25 °C			-40 °C to +85 °C		
	Minimum Value, kHz	Maximum Value, kHz	Error, %	Minimum Value, kHz	Maximum Value, kHz	Error, %
2.048 kHz OSC0	2.029	2.065	+0.83	1.935	2.075	+1.32
			-0.93			-5.52
2.048 MHz OSC1	2023	2071	+1.12	2007	2073	+1.22
			-1.22			-2.00
25 MHz OSC2	24676	25323	+1.29	24144	25323	+1.29
			-1.30			-3.42

3.8.1 OSC Power-On Delay

Table 16: Oscillators Power-On Delay at $T = 25\text{ °C}$, OSC Power Setting: "Auto Power-On"

Power Supply Range (V_{DD}), V	OSC0 2.048 kHz		OSC1 2.048 MHz		OSC2 25 MHz		OSC2 25 MHz Start with Delay	
	Typical Value, μs	Maximum Value, μs	Typical Value, ns	Maximum Value, ns	Typical Value, ns	Maximum Value, ns	Typical Value, ns	Maximum Value, ns
2.50	492	559	491	500	46	53	145	153
3.30	490	525	489	501	32	37	140	148
4.00	489	509	489	509	26	31	139	146
5.00	488	495	488	530	22	26	138	146
5.50	488	499	487	532	20	24	138	145

3.9 ACMP CHARACTERISTICS

Table 17: ACMP Specifications at $T = -40\text{ °C to }+85\text{ °C}$, $V_{DD} = 2.4\text{ V to }5.5\text{ V}$ Unless Otherwise Noted

Parameter	Description	Conditions	Note	Min	Typ	Max	Unit
V_{ACMP}	ACMP Input Voltage Range	Positive Input		0	--	V_{DD}	V
		Negative Input		0	--	V_{DD}	V
V_{offset}	ACMP Input Offset	ACMPxL, $V_{hys} = 0\text{ mV}$, Gain = 1, $V_{ref} = 32\text{ mV to }2048\text{ mV}$	$T = -40\text{ °C to }+85\text{ °C}$	-6.27	--	3.67	mV
			$T = 25\text{ °C}$	-5.76	-0.98	3.39	mV
	Chopper ACMP Input Offset		$T = -40\text{ °C to }+85\text{ °C}$	-0.24	--	0.49	mV
			$T = 25\text{ °C}$	-0.12	0.11	0.39	mV
t_{start}	ACMP Startup Time when BG ON	ACMP Power-On delay, Minimal required wake time for the "Wake and Sleep function", for ACMPxL	$T = -40\text{ °C to }+85\text{ °C}$	--	51.0	99.6	μs
	ACMP Startup Time when BG OFF			--	1729	2822	μs
R_{sin}	Series Input Resistance	Gain = 1x		--	10	--	G Ω
		Gain = 0.5x		--	1.6	--	M Ω
		Gain = 0.33x		--	1.6	--	M Ω
		Gain = 0.25x		--	1.6	--	M Ω

SLG47004

GreenPAK Programmable Mixed-Signal Matrix with In-System Programmability and Advanced Analog Features

Table 17: ACMP Specifications at T = -40 °C to +85 °C, V_{DD} = 2.4 V to 5.5 V Unless Otherwise Noted(Continued)

Parameter	Description	Conditions	Note	Min	Typ	Max	Unit
PROP	Propagation Delay, Response Time	ACMPxL, Vref = 1.024 V, Gain = 1, Overdrive = 100 mV	Low to High	--	2.59	3.66	µs
			High to Low	--	2.80	5.21	µs
		ACMPxL, Vref = 32 mV to 2048 mV, Gain = 1, Overdrive = 100 mV	Low to High	--	2.83	5.16	µs
			High to Low	--	2.96	7.63	µs
		ACMPxL, Vref = 1.024 V, Gain = 1, Overdrive = 10 mV	Low to High	--	8.18	12.57	µs
			High to Low	--	9.14	18.54	µs
ACMPxL, Vref = 32 mV to 2048 mV, Gain = 1, Overdrive = 10 mV	Low to High	--	9.16	21.41	µs		
	High to Low	--	10.01	32.37	µs		
G	Gain Error	G = 1		1	1	1	
		G = 0.5		0.496	0.5	0.504	
		G = 0.33		0.331	0.330	0.336	
		G = 0.25		0.248	0.250	0.253	

3.10 INTERNAL VREF CHARACTERISTICS

Table 18: Internal Vref Characteristics at V_{DD} = 2.4 V to 5.5 V

Parameter	Description	Conditions	Note	Min	Typ	Max	Unit
Vref Accuracy and Loading	Internal Vref Accuracy at Vref > 1216 mV	No loading	T = 25 °C	-0.30	--	0.18	%
			T = -40 °C to +85 °C	-0.73	--	0.19	%
Vref _{ACCURACY}	Vref Divider Accuracy	Vref from (16/64) to (64/64)	T = -40 °C to +85 °C	-0.38	0.04	0.37	%
		Vref from (1/64) to (64/64)	T = -40 °C to +85 °C	-1.94	0.02	1.31	%
Vref _{OFFSET}	Vref Divider Offset	Vref from (16/64) to (64/64)	T = -40 °C to +85 °C	-5.58	0.83	7.84	mV
		Vref from (1/64) to (64/64)	T = -40 °C to +85 °C	-5.58	0.62	7.84	mV

3.11 OUTPUT BUFFERS CHARACTERISTICS

Table 19: HD Buffer Electrical Characteristics at T = -40 °C to +85 °C, V_{DD} = 2.4 V to 5.5 V Unless Otherwise Noted

Parameter	Description	Conditions	Min	Typ	Max	Unit
Offset						
V _{OFFSET}	Input Offset Voltage	V _{DDA} = 5 V, V _{OUT} = 0.5 V to 4 V, T = 25 °C	--	0.25	8.0	mV
		V _{DDA} = 5 V, V _{OUT} = 0.5 V to 4 V	--	--	9.0	mV
dV _{OFFSET} /dt	Offset Drift with Temperature	V _{OUT} = V _{DDA} /2	--	0.75	13.5	µV/C
Output						

SLG47004

GreenPAK Programmable Mixed-Signal Matrix with In-System Programmability and Advanced Analog Features

Table 19: HD Buffer Electrical Characteristics at T = -40 °C to +85 °C, V_{DD} = 2.4 V to 5.5 V Unless Otherwise Noted

Parameter	Description	Conditions	Min	Typ	Max	Unit
$\Delta V_{OUT(I)}$	Load Regulation	$V_{DDA} = 5\text{ V}$, $V_{OUT} = 2.048\text{ V}$, $I_{LOAD} = 0.5\text{ mA to }2\text{ mA}$, $T = 25\text{ °C}$	--	0.2	1.2	mV
		$V_{DDA} = 5\text{ V}$, $V_{OUT} = 2.048\text{ V}$, $I_{LOAD} = 0.5\text{ mA to }5\text{ mA}$, $T = 25\text{ °C}$		0.4	1.9	mV
$\Delta V_{OUT(U)}$	Line Regulation	$V_{DDA} = 2.5\text{ V to }5\text{ V}$, $V_{OUT} = 2.048\text{ V}$, $T = 25\text{ °C}$	--	0.9	5.0	mV
I_{SC}	Short Circuit Current	$V_{DDA} = 2.4\text{ V to }5.5\text{ V}$	--	67.8	--	mA
Shutdown Characteristics						
t_{on}	Buffer Turn-On Time	$R_{LOAD} = 5\text{ k}\Omega$, $T = 25\text{ °C}$,	--	--	50	μs
t_{off}	Buffer Turn-Off Time	$R_{LOAD} = 5\text{ k}\Omega$, $T = 25\text{ °C}$	--	0.071	--	μs

Table 20: Vref Output Buffer at T = -40 °C to +85 °C, V_{DD} = 2.4 V to 5.5 V Unless Otherwise Noted

Parameter	Description	Conditions	Note	Min	Typ	Max	Unit	
$\Delta V_{OUT(I)}$	Load Regulation	$V_{DDA} = 5\text{ V}$, $V_{OUT} = 2.048\text{ V}$, $I_{LOAD} = 0.5\text{ mA to }2\text{ mA}$, $T = 25\text{ °C}$	--	-0.99	--	1.21	mV	
		$V_{DDA} = 5\text{ V}$, $V_{OUT} = 2.048\text{ V}$, $I_{LOAD} = 0.5\text{ mA to }5\text{ mA}$, $T = 25\text{ °C}$	--	-0.99	--	1.39	mV	
$\Delta V_{OUT(U)}$	Line Regulation	$V_{DDA} = 2.5\text{ V to }5\text{ V}$, $V_{OUT} = 2.048\text{ V}$, $T = 25\text{ °C}$	--	-2.97	--	5.13	mV	
Vref Buffer Accuracy and Loading	Vref Output Buffer Offset	$V_{ref} < 1024\text{ mV}$, $V_{DDA} = 2.4\text{ V to }5.5\text{ V}$, No Loading	$T = 25\text{ °C}$	-11.2	--	10.0	mV	
				-12.2	--	10.6	mV	
		$V_{ref} = 1024\text{ mV to }1600\text{ mV}$, $V_{DDA} = 2.4\text{ V to }5.5\text{ V}$, No Loading	$T = 25\text{ °C}$	-6.8	--	6.2	mV	
				-7.3	--	6.9	mV	
		$V_{ref} > 1600\text{ mV}$, $V_{DDA} = 2.4\text{ V to }5.5\text{ V}$, No Loading	$T = 25\text{ °C}$	-11.1	--	11.6	mV	
				-12.0	--	12.9	mV	
	Vref0 Buffer Output Capacitance Loading			Load Resistance = 1 M Ω	--	--	5	pF
				Load Resistance = 560 k Ω	--	--	10	pF
				Load Resistance = 100 k Ω	--	--	40	pF
				Load Resistance = 10 k Ω	--	--	80	pF
				Load Resistance = 2 k Ω	--	--	120	pF
				Load Resistance = 1 k Ω , $V_{ref} = 32\text{ mV to }1024\text{ mV}$	--	--	150	pF

SLG47004

GreenPAK Programmable Mixed-Signal Matrix with In-System Programmability and Advanced Analog Features

3.12 ANALOG TEMPERATURE SENSOR CHARACTERISTICS

Table 21: TS Output vs Temperature (Output Range 1)

T, °C	V _{DD} = 2.5 V		V _{DD} = 3.3 V		V _{DD} = 5.0 V	
	Typical, mV	Accuracy, %	Typical, mV	Accuracy, %	Typical, mV	Accuracy, %
-40	991	±0.41	989	±0.38	989	±0.33
-30	968	±0.35	967	±0.32	966	±0.33
-20	945	±0.33	944	±0.31	943	±0.34
-10	922	±0.37	921	±0.35	920	±0.38
0	899	±0.39	898	±0.38	897	±0.42
10	876	±0.41	875	±0.39	874	±0.43
20	853	±0.41	852	±0.39	851	±0.44
30	830	±0.45	828	±0.44	828	±0.48
40	806	±0.52	805	±0.51	804	±0.55
50	782	±0.56	781	±0.55	780	±0.60
60	758	±0.62	756	±0.61	756	±0.65
70	733	±0.70	732	±0.69	731	±0.73
80	709	±0.77	707	±0.76	707	±0.80
85	696	±0.81	695	±0.80	694	±0.84

Table 22: TS Output vs Temperature (Output Range 2)

T, °C	V _{DD} = 2.5 V		V _{DD} = 3.3 V		V _{DD} = 5.0 V	
	Typical, mV	Accuracy, %	Typical, mV	Accuracy, %	Typical, mV	Accuracy, %
-40	1195	±0.39	1194	±0.34	1193	±0.34
-30	1168	±0.37	1166	±0.35	1165	±0.36
-20	1141	±0.37	1139	±0.35	1138	±0.36
-10	1113	±0.40	1111	±0.39	1110	±0.41
0	1085	±0.43	1084	±0.42	1083	±0.44
10	1057	±0.44	1056	±0.43	1055	±0.45
20	1029	±0.45	1028	±0.44	1027	±0.45
30	1001	±0.48	999	±0.47	999	±0.50
40	972	±0.54	971	±0.53	970	±0.56
50	943	±0.58	942	±0.57	941	±0.60
60	914	±0.64	913	±0.63	912	±0.66
70	885	±0.72	883	±0.71	882	±0.74
80	855	±0.79	854	±0.77	853	±0.81
85	840	±0.83	839	±0.81	838	±0.84

SLG47004

GreenPAK Programmable Mixed-Signal Matrix with In-System Programmability and Advanced Analog Features

3.13 PROGRAMMABLE OPERATIONAL AMPLIFIER CHARACTERISTICS

Table 23: EC of OA, $V_{DDA} = 2.4\text{ V to }5.5\text{ V}$, $V_{CM} = V_{DDA}/2$, $V_{OUT} \approx V_{DDA}/2$, $R_L = 100\text{ k}\Omega$ to $V_{DDA}/2$, $C_L = 50\text{ pF}$, $T = 25\text{ }^\circ\text{C}$

Parameter	Description	Conditions (Note 1)	Min	Typ	Max	Unit
Input Voltage Offset (without Customers Trimming, Included Factory Block Offset Trim)						
V_{OFFSET}	Input Offset Voltage	$BW = 128\text{ kHz}$	--	69	500	μV
		$BW = 128\text{ kHz}$, $T = -40\text{ }^\circ\text{C to }+85\text{ }^\circ\text{C}$	--	69	930	μV
		$BW = 512\text{ kHz}$	--	56	500	μV
		$BW = 512\text{ kHz}$, $T = -40\text{ }^\circ\text{C to }+85\text{ }^\circ\text{C}$	--	56	1230	μV
		$BW = 2\text{ MHz}$	--	47	500	μV
		$BW = 2\text{ MHz}$, $T = -40\text{ }^\circ\text{C to }+85\text{ }^\circ\text{C}$	--	47	1030	μV
		$BW = 8\text{ MHz}$	--	35	243	μV
		$BW = 8\text{ MHz}$, $T = -40\text{ }^\circ\text{C to }+85\text{ }^\circ\text{C}$	--	35	643	μV
dV_{OFFSET}/dt	Offset Drift with Temperature	$V_{CM} = V_{DD}/2$, $T = -40\text{ }^\circ\text{C to }+85\text{ }^\circ\text{C}$	--	0.6	13.0	$\mu\text{V}/^\circ\text{C}$
		$V_{CM} = \text{GND}$, $T = -40\text{ }^\circ\text{C to }+85\text{ }^\circ\text{C}$	--	0.5	12.6	$\mu\text{V}/^\circ\text{C}$
$dV_{\text{OFFSET}}/\text{Time}$	Long-Term Offset Voltage Drift	$V_{CM} = V_{DD}/2$	0	--	985	μV
Trimmed Input Offset (Customer Perspective after Using Digital Rheostats with Gain = 200x) (Note 2)						
V_{OFFSET}	Input Offset Voltage	$V_{CM} = V_{DD}/2$	--	--	5	μV
Input Voltage Range						
V_{CMR}	Input Common-Mode Voltage Range	$T = -40\text{ }^\circ\text{C to }+85\text{ }^\circ\text{C}$	-0.2	--	$V_{DD} + 0.2$	V
CMRR	Common-Mode Rejection Ratio	All Op Amps, $\text{GND} + 0.8\text{ V} < V_{CM} < V_{DD} - 0.8\text{ V}$, $T = -40\text{ }^\circ\text{C to }+85\text{ }^\circ\text{C}$	73.5	102	--	dB
		All Op Amps, $\text{GND} < V_{CM} < \text{GND} + 0.8\text{ V}$ or $V_{DD} - 0.8\text{ V} < V_{CM} < V_{DD}$	69.7	101	--	dB
		Op Amp0 and Op Amp1, $\text{GND} + 0.8\text{ V} < V_{CM} < V_{DD} - 0.8\text{ V}$, $T = -40\text{ }^\circ\text{C to }+85\text{ }^\circ\text{C}$	73.5	103	--	dB
		Op Amp0 and Op Amp1, $\text{GND} < V_{CM} < \text{GND} + 0.8\text{ V}$ or $V_{DD} - 0.8\text{ V} < V_{CM} < V_{DD}$	69.7	102	--	dB
		Internal Op Amp, $\text{GND} + 0.8\text{ V} < V_{CM} < V_{DD} - 0.8\text{ V}$, $T = -40\text{ }^\circ\text{C to }+85\text{ }^\circ\text{C}$	77.6	100	--	dB
		Internal Op Amp, $\text{GND} < V_{CM} < \text{GND} + 0.8\text{ V}$ or $V_{DD} - 0.8\text{ V} < V_{CM} < V_{DD}$	69.7	100	--	dB
PSRR	Power Supply Rejection Ratio	$V_{CM} = V_{DD}/2$, $T = -40\text{ }^\circ\text{C to }+85\text{ }^\circ\text{C}$	80	101	--	dB
		$V_{CM} = \text{GND}$, $T = -40\text{ }^\circ\text{C to }+85\text{ }^\circ\text{C}$	83	102	--	dB

SLG47004

GreenPAK Programmable Mixed-Signal Matrix with In-System Programmability and Advanced Analog Features

Table 23: EC of OA, $V_{DDA} = 2.4\text{ V to }5.5\text{ V}$, $V_{CM} = V_{DDA}/2$, $V_{OUT} \approx V_{DDA}/2$, $R_L = 100\text{ k}\Omega$ to $V_{DDA}/2$, $C_L = 50\text{ pF}$, $T = 25\text{ }^\circ\text{C}$

Parameter	Description	Conditions (Note 1)	Min	Typ	Max	Unit
CS	Channel Separation	$V_{DD} = 5\text{ V}$, $f = 10\text{ Hz}$	--	119	--	dB
		$V_{DD} = 5\text{ V}$, $f = 1\text{ kHz}$	--	112	--	dB
Input Current and Impedance						
I_B	Input Bias Current		--	1.9	± 9	pA
		$T = -40\text{ }^\circ\text{C to }+85\text{ }^\circ\text{C}$	--	1.9	± 258	pA
I_{OFFSET}	Input Offset Current		--	--	3.2	pA
		$T = +85\text{ }^\circ\text{C}$	--		210	pA
R_{CM}	Common-Mode Input Resistance		--	3×10^{12}	--	Ω
R_{DIFF}	Differential Input Resistance		--	10^{13}	--	Ω
C_{CM}	Input Capacitance Common-Mode		--	5	7	pF
C_{DIFF}	Input Capacitance Differential		--	1.98	2.27	pF
Open-Loop Gain						
A_{OL}	DC Open Loop Gain	$R_{LOAD} = 1\text{ M}\Omega$, $GND + 0.1\text{ V} < V_{OUT} < V_{DD} - 0.1\text{ V}$, $T = -40\text{ }^\circ\text{C to }+85\text{ }^\circ\text{C}$	103.3	125	--	dB
		$R_{LOAD} = 50\text{ k}\Omega$, $GND + 0.5\text{ V} < V_{OUT} < V_{DD} - 0.5\text{ V}$, $T = -40\text{ }^\circ\text{C to }+85\text{ }^\circ\text{C}$	103.4	125	--	dB
Output						
V_{OH}	Maximum Voltage Swing	$R_{LOAD} = 50\text{ k}\Omega$, $T = -40\text{ }^\circ\text{C to }+85\text{ }^\circ\text{C}$	$V_{DD} - 5.73$	--	--	mV
		$BW = 8.192\text{ MHz}$, $R_{LOAD} = 600\text{ }\Omega$, $T = -40\text{ }^\circ\text{C to }+85\text{ }^\circ\text{C}$	$V_{DD} - 135$	--	--	mV
V_{OL}		$R_{LOAD} = 50\text{ k}\Omega$, $T = -40\text{ }^\circ\text{C to }+85\text{ }^\circ\text{C}$	--	--	$GND + 3.122$	mV
		$BW = 8.192\text{ MHz}$, $R_{LOAD} = 600\text{ }\Omega$, $T = -40\text{ }^\circ\text{C to }+85\text{ }^\circ\text{C}$	--	--	$GND + 101$	mV
V_{OSR}	Linear Output Swing Range	V_{OVR} from Rail $R_{LOAD} = 1\text{ M}\Omega$	$GND + 100$	--	$V_{DD} - 100$	mV

SLG47004

GreenPAK Programmable Mixed-Signal Matrix with In-System Programmability and Advanced Analog Features

Table 23: EC of OA, $V_{DDA} = 2.4\text{ V to }5.5\text{ V}$, $V_{CM} = V_{DDA}/2$, $V_{OUT} \approx V_{DDA}/2$, $R_L = 100\text{ k}\Omega\text{ to }V_{DDA}/2$, $C_L = 50\text{ pF}$, $T = 25\text{ }^\circ\text{C}$

Parameter	Description	Conditions (Note 1)	Min	Typ	Max	Unit		
I_{SC}	Short Circuit Current	I_{SC} to GND	BW = 128 kHz, T = -40 °C to +85 °C	--	10.8	--	mA	
			BW = 512 kHz, T = -40 °C to +85 °C	--	14.4	--	mA	
			BW = 2.048 MHz, T = -40 °C to +85 °C	--	22.5	--	mA	
			BW = 8.192 MHz, T = -40 °C to +85 °C	--	52.0	--	mA	
		I_{SC} to V_{DD}	BW = 128 kHz, T = -40 °C to +85 °C			20.6	--	mA
			BW = 512 kHz, T = -40 °C to +85 °C			27.0	--	mA
			BW = 2.048 MHz, T = -40 °C to +85 °C			41.1	--	mA
			BW = 8.192 MHz, T = -40 °C to +85 °C			92.1	--	mA
C_{LOAD}	Capacitive Load Drive		See Section 10.3 (Small Signal Overshoot vs. Capacitive Load plots)					
Power Supply								
V_{DD}	Supply Voltage	Guaranteed by PSRR Test	2.4	--	5.5	V		
I_Q (including charge pump current consumption)	Quiescent Current per Amplifier, BW = 128 kHz	T = 25 °C, $V_{DDA} = 2.5\text{ V to }5.5\text{ V}$	--	33.3	47	μA		
		T = -40 °C to +85 °C, $V_{DDA} = 2.5\text{ V to }5.5\text{ V}$	--	34.1	59	μA		
	Quiescent Current per Amplifier, BW = 512 kHz	T = 25 °C, $V_{DDA} = 2.5\text{ V to }5.5\text{ V}$	--	89.8	101	μA		
		T = -40 °C to +85 °C, $V_{DDA} = 2.5\text{ V to }5.5\text{ V}$	--	91.1	124	μA		
	Quiescent Current per Amplifier, BW = 2.048 MHz	T = 25 °C, $V_{DDA} = 2.5\text{ V to }5.5\text{ V}$	--	238.7	255	μA		
		T = -40 °C to +85 °C, $V_{DDA} = 2.5\text{ V to }5.5\text{ V}$	--	238.9	274	μA		
	Quiescent Current per Amplifier, BW = 8.192 MHz	T = 25 °C, $V_{DDA} = 2.5\text{ V to }5.5\text{ V}$	--	611.5	652	μA		
		T = -40 °C to +85 °C, $V_{DDA} = 2.5\text{ V to }5.5\text{ V}$	--	611.6	701	μA		
I_Q (including charge pump current consumption)	Full Shutdown	T = 25 °C	--	105.8	--	nA		
	Partial Shutdown (Note 3), BW = 128 kHz	T = 25 °C	--	7.3	--	μA		
	Partial Shutdown (Note 3), BW = 8.192 MHz	T = 25 °C	--	21.3	--	μA		
Frequency Response								

**GreenPAK Programmable Mixed-Signal Matrix
with In-System Programmability and Advanced Analog Features**
Table 23: EC of OA, $V_{DDA} = 2.4\text{ V to }5.5\text{ V}$, $V_{CM} = V_{DDA}/2$, $V_{OUT} \approx V_{DDA}/2$, $R_L = 100\text{ k}\Omega$ to $V_{DDA}/2$, $C_L = 50\text{ pF}$, $T = 25\text{ }^\circ\text{C}$

Parameter	Description	Conditions (Note 1)	Min	Typ	Max	Unit	
GBW	Gain Bandwidth Product	$R_{LOAD} = 10\text{ k}\Omega$, $C_{LOAD} = 20\text{ pF}$, $G = +1\text{ V/V}$, $T = -40\text{ }^\circ\text{C}$ to $+85\text{ }^\circ\text{C}$	$BW = 128\text{ kHz}$	--	124	--	kHz
			$BW = 512\text{ kHz}$	--	542	--	kHz
			$BW = 2.048\text{ MHz}$	--	2569	--	kHz
			$BW = 8.192\text{ MHz}$	--	9594	--	kHz
PM	Phase Margin	$G = +1\text{ V/V}$, $BW = 128\text{ kHz} \rightarrow 8.192\text{ MHz}$; $R_{LOAD} = 10\text{ k}\Omega$, $C_{LOAD} = 20\text{ pF}$, $T = -40\text{ }^\circ\text{C}$ to $+85\text{ }^\circ\text{C}$	43	71	--	degree	
SR	Slew Rate	$R_{LOAD} = 50\text{ k}\Omega$, $C_{LOAD} = 85\text{ pF}$	$BW = 128\text{ kHz}$, $T = -40\text{ }^\circ\text{C}$ to $+85\text{ }^\circ\text{C}$	--	0.09	--	V/ μs
			$BW = 512\text{ kHz}$, $T = -40\text{ }^\circ\text{C}$ to $+85\text{ }^\circ\text{C}$	--	0.38	--	V/ μs
			$BW = 2.048\text{ MHz}$, $T = -40\text{ }^\circ\text{C}$ to $+85\text{ }^\circ\text{C}$	--	1.85	--	V/ μs
			$BW = 8.192\text{ MHz}$, $T = -40\text{ }^\circ\text{C}$ to $+85\text{ }^\circ\text{C}$	--	6.48	--	V/ μs
t_{OR}	Overload Recovery Time	$T = -40\text{ }^\circ\text{C}$ to $+85\text{ }^\circ\text{C}$ $R_{LOAD} = 50\text{ k}\Omega$	--	12.68	--	μs	
Noise							
THD	Total Harmonic Distortion	$AV = 1$, $R_{LOAD} = 50\text{ k}\Omega$, $V_{OUT(PP)} = V_{DD}/2$	$f = 1\text{ kHz}$, $BW = 128\text{ kHz}$	--	0.171	--	%
			$f = 1\text{ kHz}$, $BW = 512\text{ kHz}$	--	0.073	--	%
			$f = 1\text{ kHz}$, $BW = 2.048\text{ MHz}$	--	0.033	--	%
			$f = 1\text{ kHz}$, $BW = 8.192\text{ MHz}$	--	0.02	--	%
e_n	Input Voltage Noise	$f = 0.1$ to 10 Hz	--	24.78	--	μVpp	
V_n	Input Voltage Noise Density	$f = 1\text{ kHz}$	$BW = 128\text{ kHz}$	--	92	--	nV/ $\sqrt{\text{Hz}}$
			$BW = 512\text{ kHz}$	--	86	--	
			$BW = 2.048\text{ MHz}$	--	74	--	
			$BW = 8.192\text{ MHz}$	--	51	--	
I_n	Input Current Noise Density	$f = 1\text{ kHz}$	--	1	--	fA/ $\sqrt{\text{Hz}}$	
Shutdown Characteristics							
t_{on}	Amplifier Turn-On Time	$BW = 8.192\text{ MHz}$, $T = -40\text{ }^\circ\text{C}$ to $+85\text{ }^\circ\text{C}$	$V_{CM} = V_{DDA}/2$, $R_L = 50\text{ k}\Omega$	--	2.143	6.095	μs
			$V_{DDA} > V_{CM} >$ $(V_{DDA} - 1.3)$	--	2.166	6.070	μs
		$BW = 128\text{ kHz}$, $T = -40\text{ }^\circ\text{C}$ to $+85\text{ }^\circ\text{C}$	$V_{CM} = V_{DDA}/2$, $R_L = 50\text{ k}\Omega$	--	25.177	43.158	μs
			$V_{DDA} > V_{CM} >$ $(V_{DDA} - 1.3)$	--	34.769	70.602	μs
t_{off}	Amplifier Turn-Off Time	--	--	0.653	1.015	μs	

SLG47004

GreenPAK Programmable Mixed-Signal Matrix with In-System Programmability and Advanced Analog Features

Table 23: EC of OA, $V_{DDA} = 2.4\text{ V to }5.5\text{ V}$, $V_{CM} = V_{DDA}/2$, $V_{OUT} \approx V_{DDA}/2$, $R_L = 100\text{ k}\Omega$ to $V_{DDA}/2$, $C_L = 50\text{ pF}$, $T = 25\text{ }^\circ\text{C}$

Parameter	Description	Conditions (Note 1)	Min	Typ	Max	Unit	
Comparator Mode							
t_{PHL}	Propagation Delay Output High to Low	Vref = 2.048 mV, Overdrive = 100 mV, Charge Pump is always On	BW = 128 kHz	--	23.6	39.4	μs
			BW = 512 kHz	--	10.8	17.9	μs
			BW = 2.048 MHz	--	6.8	11.5	μs
			BW = 8.192 MHz	--	5.6	10.0	μs
t_{PLH}	Propagation Delay Output Low to High		BW = 128 kHz	--	24.6	40.1	μs
			BW = 512 kHz	--	10.6	17.2	μs
			BW = 2.048 MHz	--	6.5	10.8	μs
			BW = 8.192 MHz	--	5.4	9.0	μs

Note 1 AGND = GND, unless otherwise noted

Note 2 Equivalent offset voltage of the amplifier after user's trim using digital rheostat. Gain of the amplifier is G=200 and the zero output voltage level $V_{zero} = V_{DD}/2$ (See Section 10.2.1)

Note 3 Op amps analog supporting blocks are always turned on.

3.14 100K DIGITAL RHEOSTAT CHARACTERISTICS

Table 24: 100K Digital Rheostat EC at $V_A=V_{DD}$, $V_B=GND$, $T=-40^\circ\text{C}$ to $+85^\circ\text{C}$, $V_{DD}=2.4\text{V}$ to 5.5V Unless Otherwise Noted

Parameter	Description	Conditions	Min	Typ	Max	Unit
V_{DR}	Rheostat Pin Voltage Range	Voltage between any (A or B) pins and AGND	AGND	--	V_{DDA}	V
R_{DR}	Digital Rheostat Resistance	Full resistance with all switches open (Note 1)	94.426	101.582	113.741	k Ω
R_{DR_MIN}	Minimal Rheostat Resistance	Code = 0x00	43.679	--	84.779	Ω
R_{MATCH}	Mismatch between rheostats	Code = 0x3FF, T = 25 $^\circ\text{C}$	--	0.084	--	%
Number of taps					1024	
$BWDT_{DR}$	Digital Rheostat Bandwidth	Frequency applied on one side of resistor chain and -3 dB frequency measured at the other side with full 100 k Ω , assume no additional load	--	50	--	kHz
R_S	Step Resistance	$V_{DD} = (2.4\text{ V}; 3.3\text{ V}; 5.5\text{ V})$ $V_{DDA} = (1\text{ V}; -1\text{ V})$ $T = (-40\text{ }^\circ\text{C}; 25\text{ }^\circ\text{C}; 85\text{ }^\circ\text{C})$	--	99.236	--	Ω
I_{DR_MAX}	Max current through Rheostat	T = 25 $^\circ\text{C}+$	--	--	2	mA
E_{SW_N}	Resistor Noise Voltage	$R_{AB} = 25\text{ k}\Omega$, f = 1 kHz	--	30	--	nV/ $\sqrt{\text{Hz}}$
f_{ChACMP}	Chopper Comparator Switching Frequency		--	--	30	kHz
V_{Ch_offset}	Chopper comparator offset when Auto-Trim process is active		--	100	300	μV
f_{DR_CLK}	Counter Frequency independent from the Rheostat	The counter frequency is determined by user selection	0	--	25	MHz

SLG47004

GreenPAK Programmable Mixed-Signal Matrix with In-System Programmability and Advanced Analog Features

Table 24: 100K Digital Rheostat EC at $V_A=V_{DD}$, $V_B=GND$, $T=-40^{\circ}C$ to $+85^{\circ}C$, $V_{DD}=2.4V$ to $5.5V$ Unless Otherwise Noted

Parameter	Description	Conditions	Min	Typ	Max	Unit
f_{DR_SWCH}	Rheostat Switch Speed (Note 2)	$V_A = 5 V$, $V_B = 0 V$, ± 1 LSB error band, Auto-Trim or Fast mode	--	--	100	kHz
		$V_A = 5 V$, $V_B = 0 V$, ± 1 LSB error band, regular mode	--	--	1	kHz
T_{settle}	Settling Time	Fast mode, I ² C code change from 0 to 1023	--	--	50	μs
		Fast mode, Rheostat 1 bit code change	--	--	10	μs
C_{DR}	Maximum Capacitance of A, B pins Measured to AGND	All switches are ON, $f = 200$ kHz	--	33.152	--	pF
I_{LKG}	Leakage Current	Including active charge pump current consumption	--	--	1000	nA
Error ZScale	Zero-Scale Error	Code = 0x00	--	--	0.776	LSB
INL	Integral Non-linearity		--	--	± 2	LSB
DNL	Differential Non-linearity		--	--	± 1	LSB
$BWDT_{CAP}$	Bandwidth -3 dB (Load = 30 pF)	$R_{RHEOSTAT} < 12.5$ k Ω	--	240	--	kHz
		$R_{RHEOSTAT} = 12.5$ k Ω to 25 k Ω	--	120	--	kHz
		$R_{RHEOSTAT} = 25$ k Ω to 50 k Ω	--	60	--	kHz
		$R_{RHEOSTAT} = 50$ k Ω to 100 k Ω	--	30	--	kHz
$\alpha R(T)$	Resistance Temperature Coefficient	$V_{AB} = \text{const}$,	-119.69	0	163.84	ppm/ $^{\circ}C$

Note 1 User can calculate actual Digital Rheostat value using calibration data from NVM (see Section 12.2).
Note 2 Includes internal timing. External circuit should be counted separately.

3.15 ANALOG SWITCHES CHARACTERISTICS

Table 25: Analog Switch/Voltage Regulator EC at $T = -40^{\circ}C$ to $+85^{\circ}C$, $V_{DD} = 2.4 V$ to $5.5 V$ Unless Otherwise Noted

Parameter	Description	Conditions	Min	Typ	Max	Unit
V_{AS}	Maximum Voltage At Pins	Voltage between any Analog Switch pin to AGND	0	--	$V_{DD} + 0.3$	V
f_{MAX}	Maximum Switching Frequency	Pull Up	2.5	--	--	MHz
		Pull Up, $V_{DD} = 2.4 V$	3.9	--	--	MHz
		Pull Down	363	--	--	kHz
		Pull Down, $V_{DD} = 2.4 V$	363	--	--	kHz
R_{ON}	ON Resistance	$V_{DD} = 3.3 V$, $V_{IN} < 1.2 V$, N-ch FET, $T = 25^{\circ}C$	--	30	53	Ω
		$V_{DD} = 3.3 V$, $V_{IN} > V_{DD} - 1.2$, P-ch FET, $T = 25^{\circ}C$	--	2	3	Ω
I_{PWROFF}	OFF Leakage Current	Switch OFF; from IN to OUT $V_A = V_{DD}$ or $V_B = V_{DD}$	--	--	17	nA

SLG47004

GreenPAK Programmable Mixed-Signal Matrix with In-System Programmability and Advanced Analog Features

Table 25: Analog Switch0/Voltage Regulator EC at T = -40 °C to +85 °C, V_{DD} = 2.4 V to 5.5 V Unless Otherwise Noted

Parameter	Description	Conditions	Min	Typ	Max	Unit
I _{SW_MAX}	Maximum ON-state Switch Current	V _A = V _{DD} , load connected to ground, V _{AB} = 0.4 V	--	--	300	mA
I _{SW_PULSE}	Maximum Pulse Current Through Switch	Pulse duration = 1 ms, Duty cycle < 5 %	--	--	500	mA

Table 26: Analog Switch1/Current Sink EC at T = -40 °C to +85 °C, V_{DD} = 2.4 V to 5.5 V Unless Otherwise Noted

Parameter	Description	Conditions	Min	Typ	Max	Unit
V _{AS}	Maximum Voltage At Pins	Voltage between any Analog Switch pin to AGND	0	--	V _{DD} + 0.3	V
f _{MAX}	Maximum Switching Frequency	Pull Up	1.6	--	--	MHz
		Pull Up, V _{DD} = 2.4 V	1.6	--	--	MHz
		Pull Down	5	--	--	MHz
		Pull Down, V _{DD} = 2.4 V	5	--	--	MHz
R _{ON}	ON Resistance	V _{DD} = 3.3 V, V _{IN} < 1.2 V, N-ch FET, T = 25 °C	--	0.8	1.5	Ω
		V _{DD} = 3.3 V, V _{IN} > V _{DD} - 1.2, P-ch FET, T = 25 °C	--	53.4	204	Ω
I _{PWROFF}	OFF Leakage Current	Switch OFF; from IN to OUT, V _A = V _{DD} or V _B = V _{DD}	--	--	34	nA
I _{SW_MAX}	Maximum ON-state Switch Current	V _A = V _{DD} , load connected to ground, V _{AB} = 0.4 V	--	--	300	mA
I _{SW_PULSE}	Maximum Pulse Current Through Switch	Pulse duration = 1 ms, Duty cycle < 5 %	--	--	500	mA

SLG47004

GreenPAK Programmable Mixed-Signal Matrix with In-System Programmability and Advanced Analog Features

4 User Programmability

The SLG47004 is a user programmable device with Multiple-Time-Programmable (MTP) memory elements that are able to configure the connection matrix and macrocells. A programming development kit allows the user the ability to create initial devices. Once the design is finalized, the programming code (.aap file) is forwarded to Renesas Electronics Corporation to integrate into a production process.

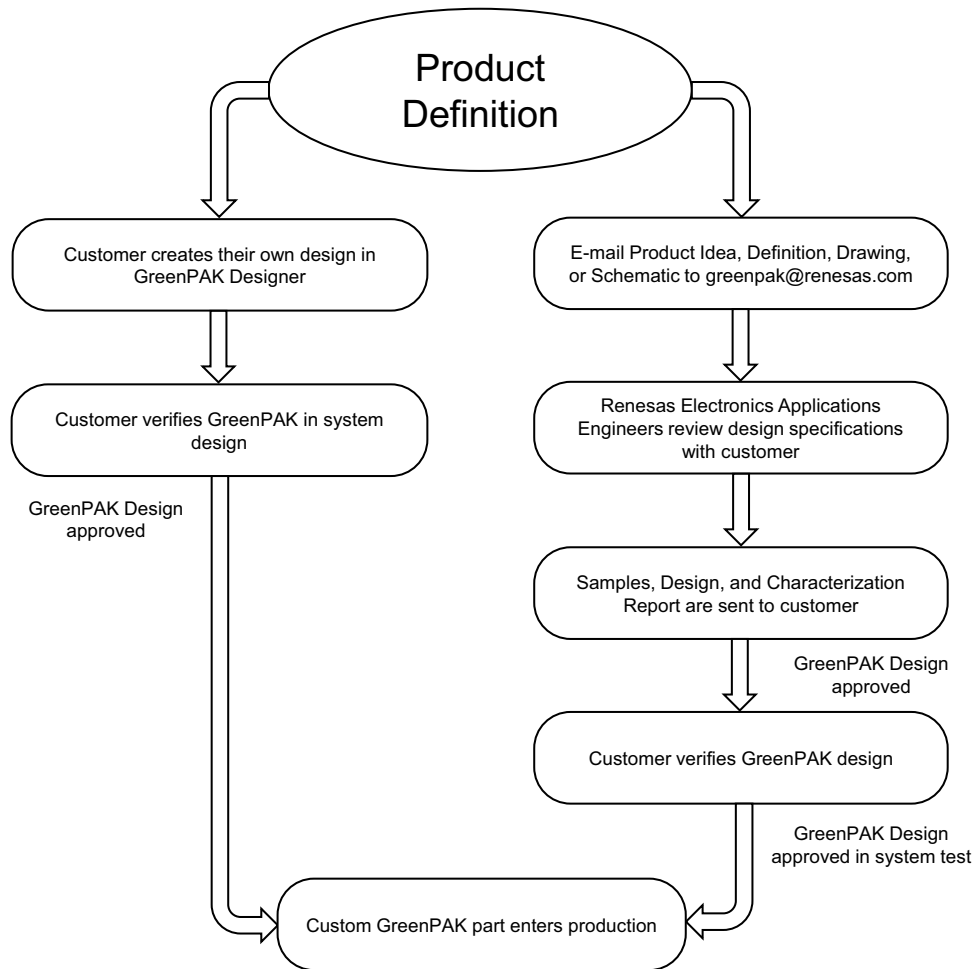

Figure 2: Steps to Create a Custom GreenPAK Device

SLG47004

GreenPAK Programmable Mixed-Signal Matrix with In-System Programmability and Advanced Analog Features

5 IO Pins

The SLG47004 has a total of 7 GPIO Pins which can function as either a user-defined Input or Output, as well as serve as a special function (such as outputting the voltage reference) and 1 GPI Pin.

5.1 GPIO PINS

IO0, IO1, IO2, IO3, IO4, IO5, and IO6 serve as General Purpose IO Pins.

5.2 GPI PINS

I0 serves as General Purpose Input Pin. It is strongly recommended to connect I0 (Pin21) to the ground if it is not used in the project.

5.3 PULL-UP/DOWN RESISTORS

All IO Pins have the option of user-selectable resistors that can be connected to the pin structure. The selectable values on these resistors are 10 k Ω , 100 k Ω , and 1 M Ω . The internal resistors can be configured as either Pull-up or Pull-downs.

5.4 FAST PULL-UP/DOWN DURING POWER-UP

During power-up, IO Pull-up/down resistance will switch to 2.6 k Ω initially and then it will switch to normal setting value. This function is enabled by register [1207].

SLG47004

GreenPAK Programmable Mixed-Signal Matrix
with In-System Programmability and Advanced Analog Features

5.5 I²C MODE IO STRUCTURE

5.5.1 I²C Mode Structure (for SCL and SDA)

Input Mode [1:0]
 00: Digital In without Schmitt Trigger, wosmt_en = 1
 01: Digital In with Schmitt Trigger, smt_en = 1
 10: Low Voltage Digital In mode 1, lv_en = 1
 11: Reserved

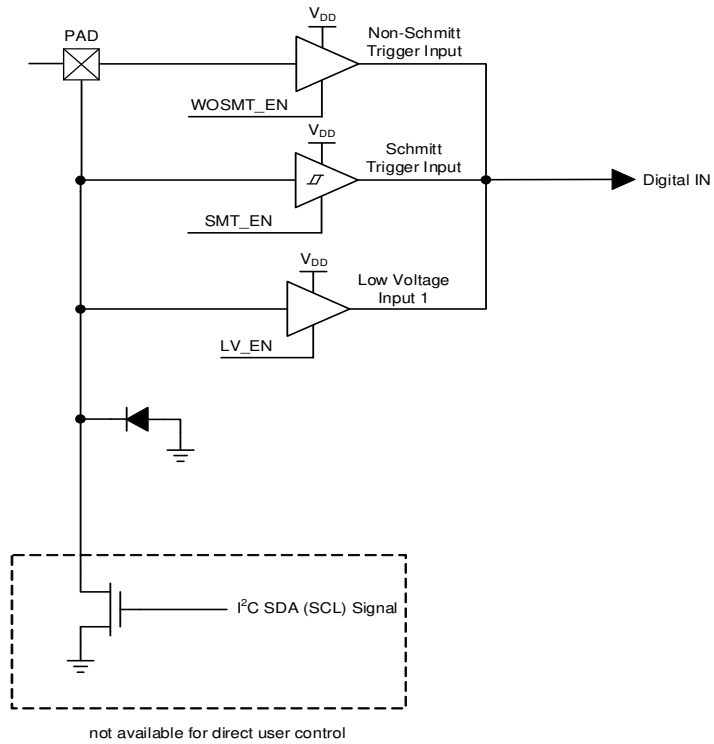

Figure 3: IO with I²C Mode IO Structure Diagram

SLG47004

GreenPAK Programmable Mixed-Signal Matrix with In-System Programmability and Advanced Analog Features

5.6 MATRIX OE IO STRUCTURE

Input Mode registers [1153:1152]
 00: Digital In without Schmitt Trigger, wosmt_en = 1
 01: Digital In with Schmitt Trigger, smt_en = 1
 10: Low Voltage Digital In mode, lv_en = 1
 11: analog IO mode

Output Mode [1:0]
 00: Push-Pull 1x mode, pp1x_en = 1
 01: Push-Pull 2x mode, pp2x_en = 1, pp1x_en = 1
 10: NMOS 1x Open-Drain mode, od1x_en = 1
 11: NMOS 2x Open-Drain mode, od2x_en = 1, od1x_en = 1

Note 1: Digital Out and OE are Matrix Output, Digital In is Matrix Input.
 Note 2: Can be varied over PVT, for reference only.

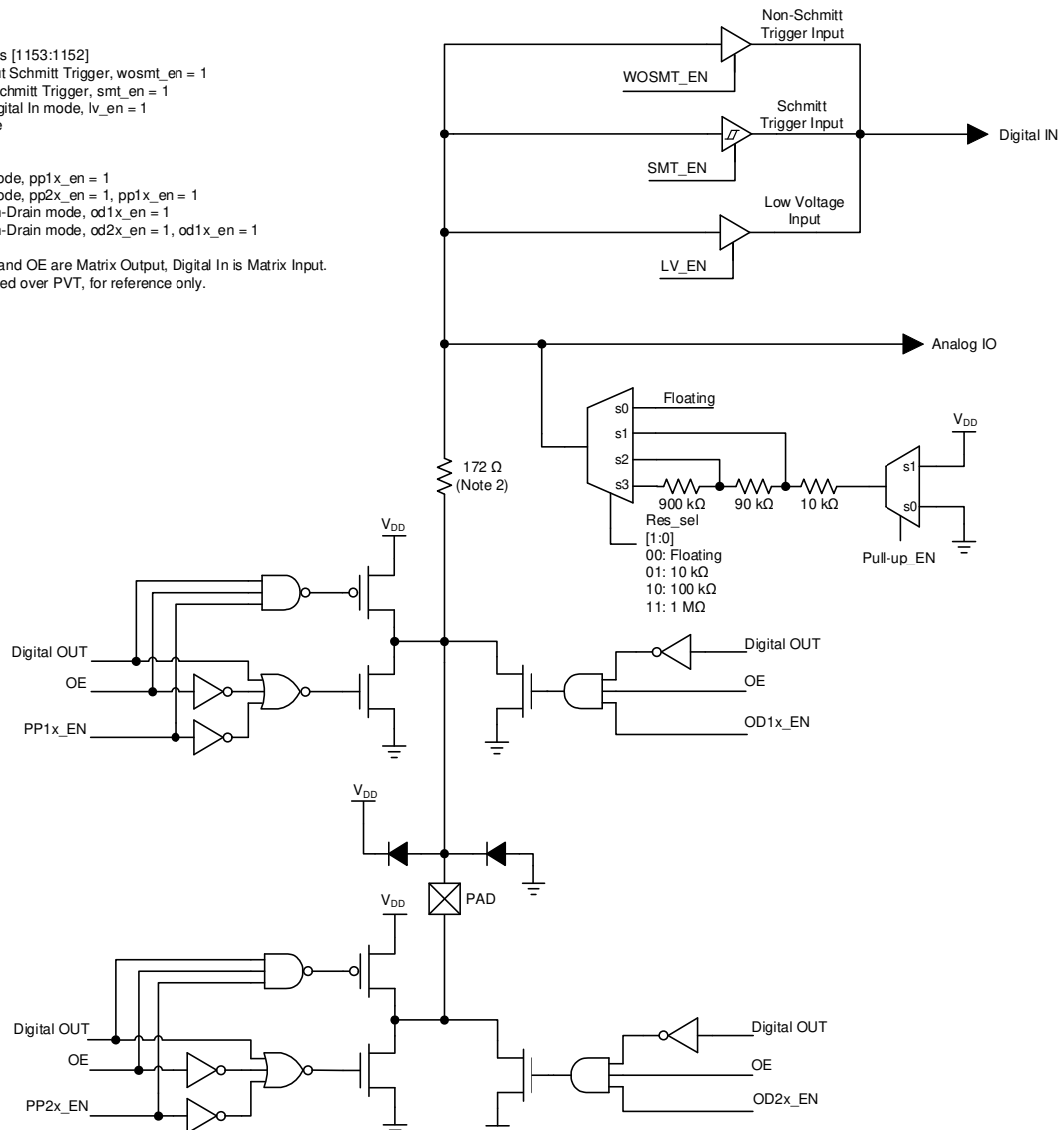

Figure 4: Matrix OE IO Structure Diagram

SLG47004

GreenPAK Programmable Mixed-Signal Matrix with In-System Programmability and Advanced Analog Features

5.7 GPI STRUCTURE

5.7.1 GPI Structure (for IO)

Input Mode [1:0]
 00: Digital In without Schmitt Trigger, wosmt_en = 1, OE=0
 01: Digital In with Schmitt Trigger, smt_en = 1, OE = 0
 10: Low Voltage Digital In mode, lv_en = 1, OE = 0
 11: Reserved

Note 1: OE cannot be selected by user.
 Note 2: OE is Matrix output, Digital In is Matrix input.

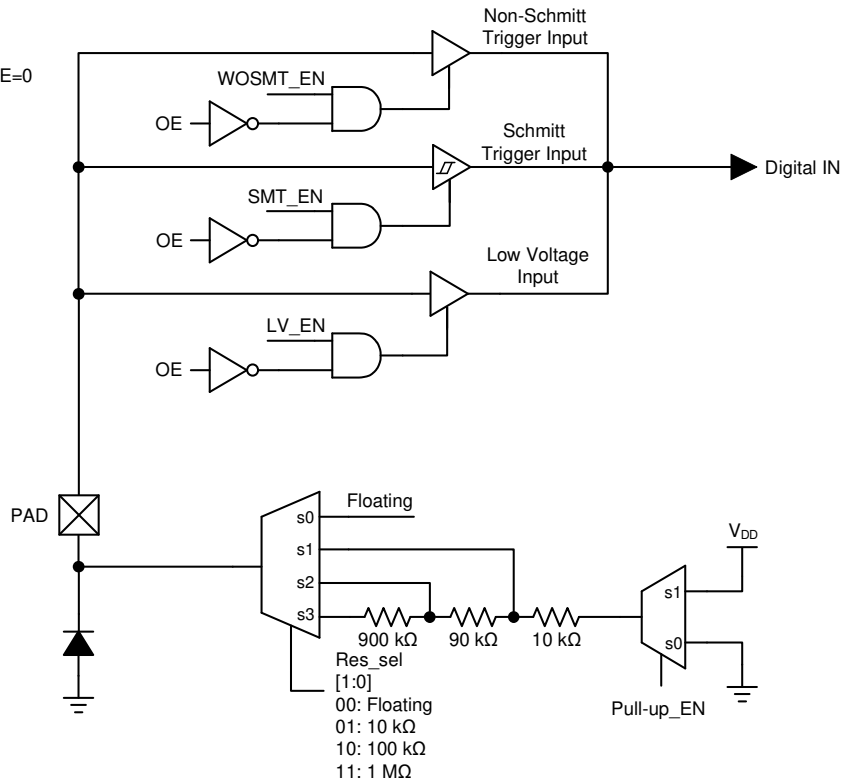

Figure 5: IO0 GPI Structure Diagram

SLG47004

GreenPAK Programmable Mixed-Signal Matrix with In-System Programmability and Advanced Analog Features

5.8 IO PINS TYPICAL PERFORMANCE

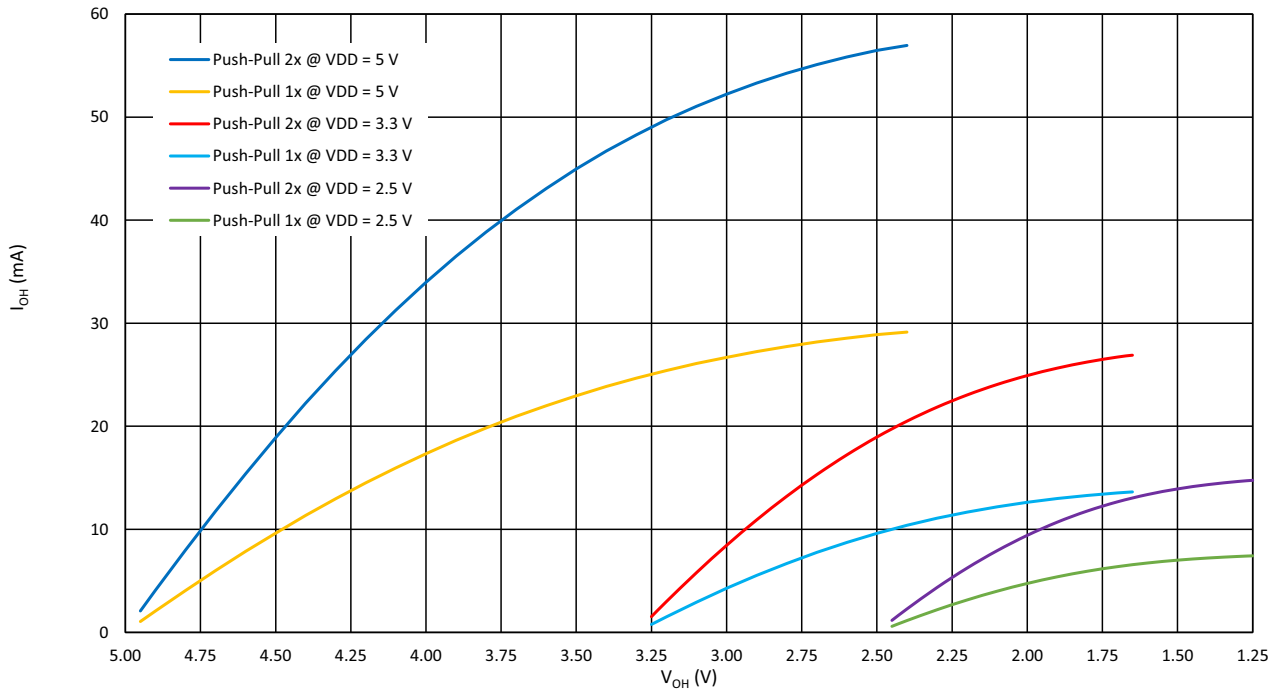

Figure 6: Typical High Level Output Current vs. High Level Output Voltage at T = 25 °C

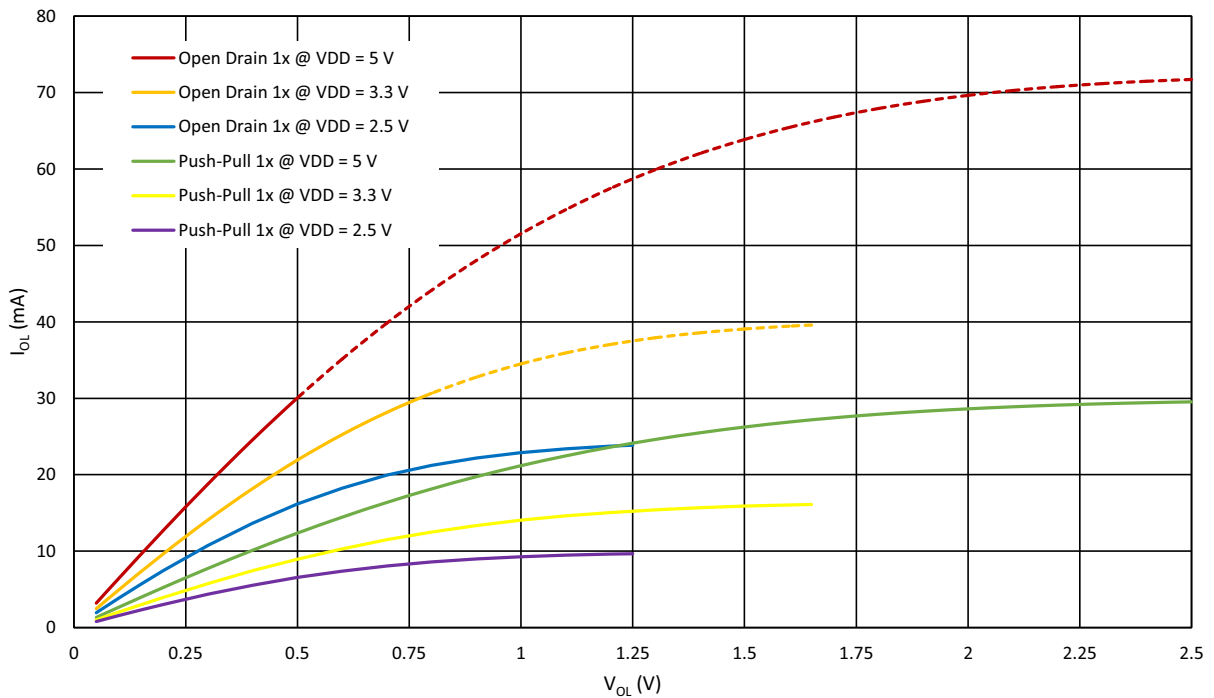

Figure 7: Typical Low Level Output Current vs. Low Level Output Voltage, 1x Drive at T = 25 °C, Full Range

SLG47004

GreenPAK Programmable Mixed-Signal Matrix with In-System Programmability and Advanced Analog Features

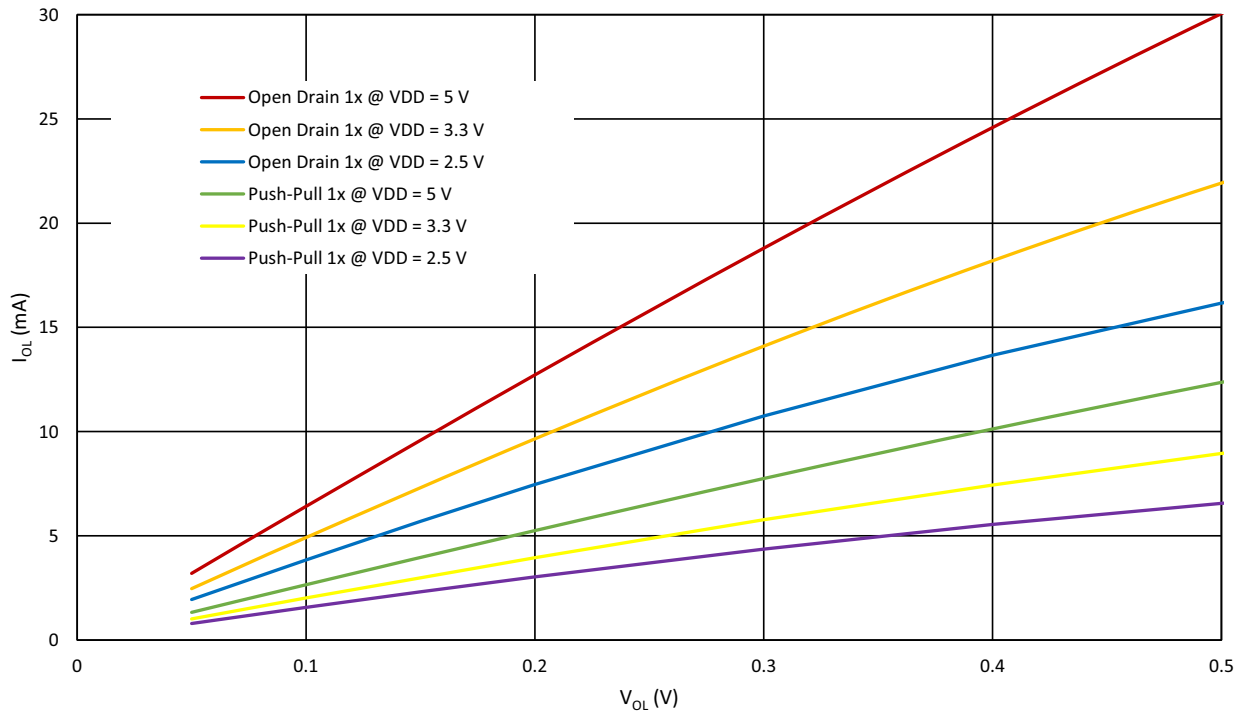

Figure 8: Typical Low Level Output Current vs. Low Level Output Voltage, 1x Drive at T = 25 °C

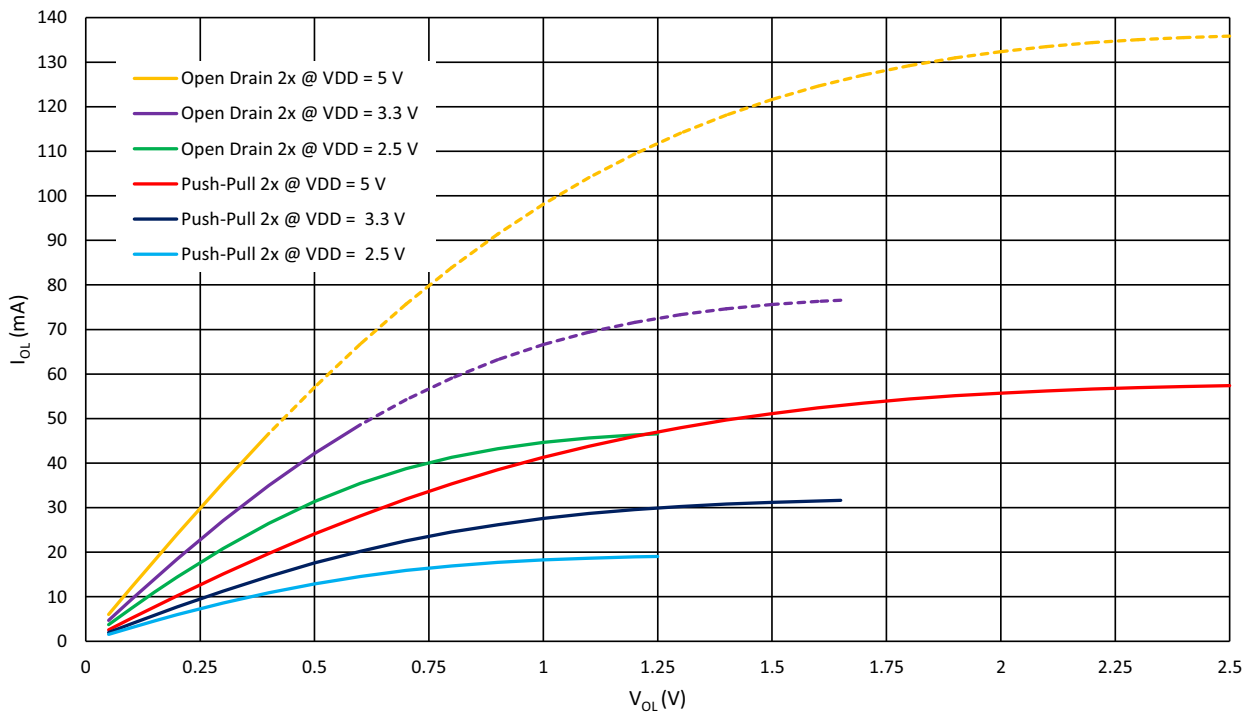

Figure 9: Typical Low Level Output Current vs. Low Level Output Voltage, 2x Drive at T = 25 °C, Full Range

SLG47004

GreenPAK Programmable Mixed-Signal Matrix
with In-System Programmability and Advanced Analog Features

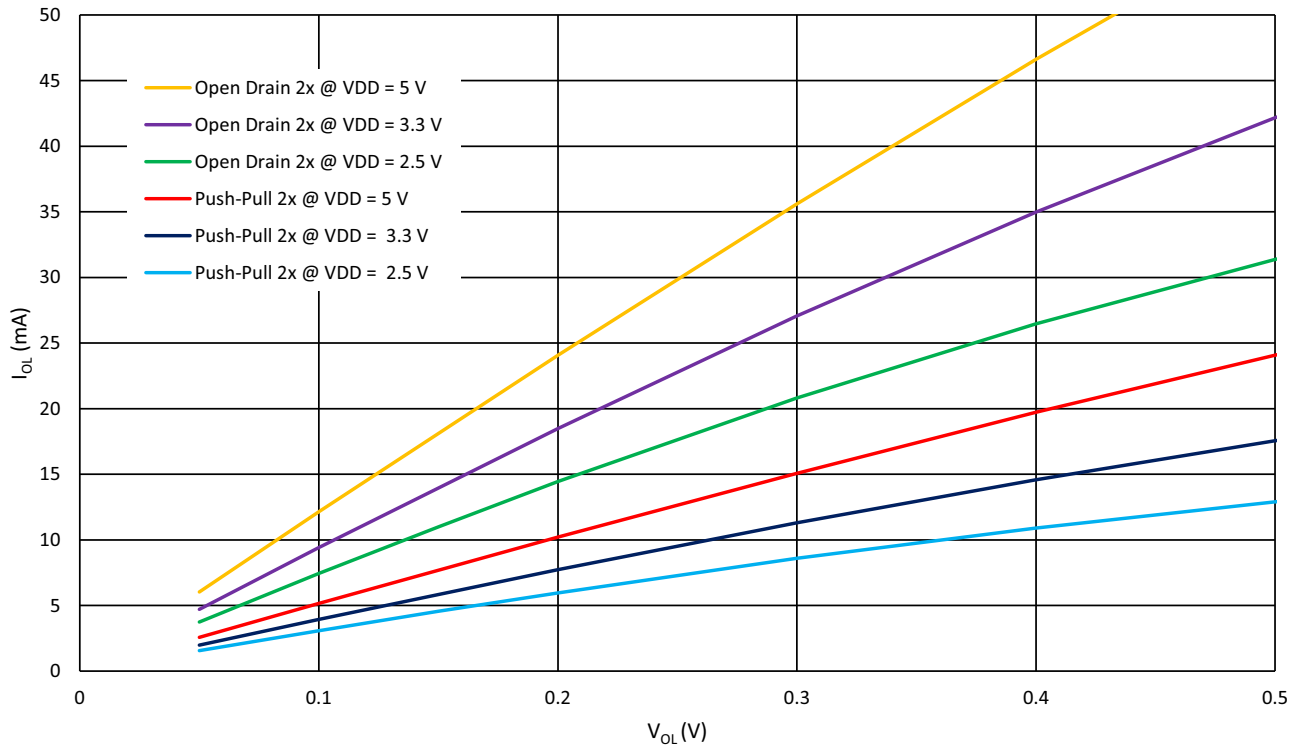

Figure 10: Typical Low Level Output Current vs. Low Level Output Voltage, 2x Drive at T = 25 °C

SLG47004

GreenPAK Programmable Mixed-Signal Matrix with In-System Programmability and Advanced Analog Features

6 Connection Matrix

The Connection Matrix in the SLG47004 is used to create an internal routing for internal functional macrocells of the device once it is programmed. The output of each functional macrocell within the SLG47004 has a specific digital bit code assigned to it, that is either set to active "High" or inactive "Low", based on the design that is created. Once the 2048 register bits within the SLG47004 are programmed, a fully custom circuit will be created.

The Connection Matrix has 64 inputs and 99 outputs. Each of the 64 inputs to the Connection Matrix is hard-wired to the digital output of a particular source macrocell, including IOs, LUTs, analog comparators, other digital resources, such as V_{DD} and GND. The input to a digital macrocell uses a 6-bit register to select one of these 64 input lines.

For a complete list of the SLG47004's register table, see Section 21.

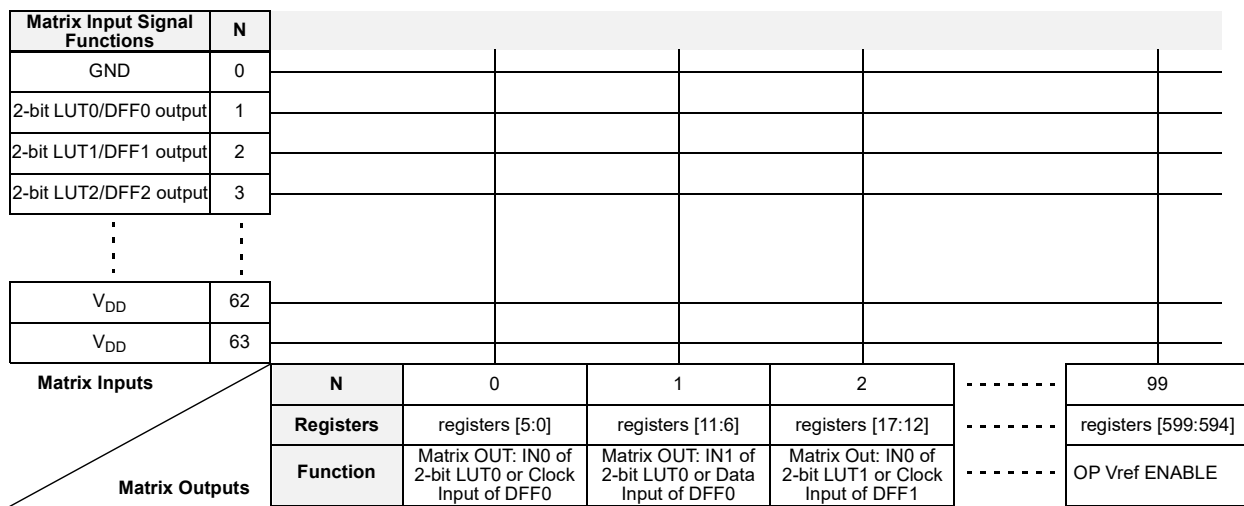

Figure 11: Connection Matrix

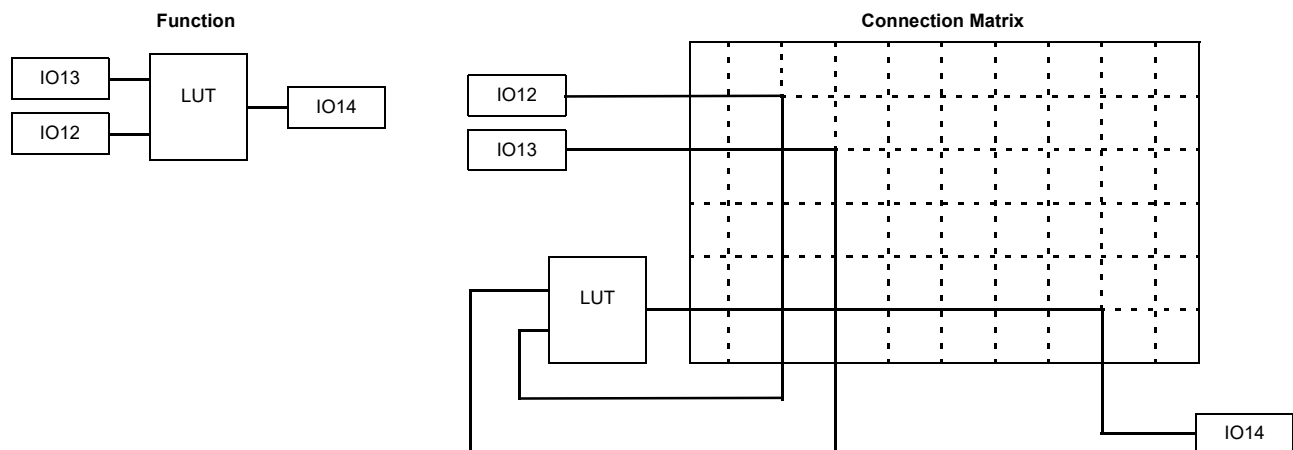

Figure 12: Connection Matrix Example

SLG47004

GreenPAK Programmable Mixed-Signal Matrix with In-System Programmability and Advanced Analog Features

6.1 MATRIX INPUT TABLE

Table 27: Matrix Input Table

Matrix Input Number	Matrix Input Signal Function	Matrix Decode					
		5	4	3	2	1	0
0	GND	0	0	0	0	0	0
1	2-bit LUT0/DFF0 output	0	0	0	0	0	1
2	2-bit LUT1/DFF1 output	0	0	0	0	1	0
3	2-bit LUT2/DFF2 output	0	0	0	0	1	1
4	2-bit LUT3/PGen output	0	0	0	1	0	0
5	3-bit LUT0/DFF3 output	0	0	0	1	0	1
6	3-bit LUT1/DFF4 output	0	0	0	1	1	0
7	3-bit LUT2/DFF5 output	0	0	0	1	1	1
8	3-bit LUT3/DFF6 output	0	0	1	0	0	0
9	3-bit LUT4/DFF7 output	0	0	1	0	0	1
10	3-bit LUT5/DFF8 output	0	0	1	0	1	0
11	3-bit LUT6/DFF9 output	0	0	1	0	1	1
12	CNT_DLY0 output	0	0	1	1	0	0
13	MLT0 4-bit LUT1/DFF17_OUT	0	0	1	1	0	1
14	CNT_DLY1 output	0	0	1	1	1	0
15	MLT1 3-bit LUT7/DFF11_OUT	0	0	1	1	1	1
16	CNT_DLY2 output	0	1	0	0	0	0
17	MLT2 3-bit LUT8/DFF12_OUT	0	1	0	0	0	1
18	CNT_DLY3 output	0	1	0	0	1	0
19	MLT3 3-bit LUT9/DFF13_OUT	0	1	0	0	1	1
20	CNT_DLY4 output	0	1	0	1	0	0
21	MLT4 3-bit LUT10/DFF14_OUT	0	1	0	1	0	1
22	CNT_DLY5 output	0	1	0	1	1	0
23	MLT5 3-bit LUT11/DFF15_OUT	0	1	0	1	1	1
24	CNT_DLY6 output	0	1	1	0	0	0
25	MLT6 3-bit LUT12/DFF16_OUT	0	1	1	0	0	1
26	3-bit LUT13/Pipe Delay/RippleCNT_out0	0	1	1	0	1	0
27	Pipe Delay/RippleCNT_out1	0	1	1	0	1	1
28	Pipe Delay/RippleCNT_out2	0	1	1	1	0	0
29	4-bit LUT0/DFF10 output	0	1	1	1	0	1
30	Programmable Delay Edge Detect Output	0	1	1	1	1	0
31	Edge Detect Filter Output	0	1	1	1	1	1
32	I ² C_virtual_0 Input	1	0	0	0	0	0
33	I ² C_virtual_1 Input	1	0	0	0	0	1
34	I ² C_virtual_2 Input	1	0	0	0	1	0
35	I ² C_virtual_3 Input	1	0	0	0	1	1
36	I ² C_virtual_4 Input	1	0	0	1	0	0
37	I ² C_virtual_5 Input	1	0	0	1	0	1

SLG47004

GreenPAK Programmable Mixed-Signal Matrix with In-System Programmability and Advanced Analog Features

Table 27: Matrix Input Table(Continued)

Matrix Input Number	Matrix Input Signal Function	Matrix Decode					
		5	4	3	2	1	0
38	I ² C_virtual_6 Input	1	0	0	1	1	0
39	I ² C_virtual_7 Input	1	0	0	1	1	1
40	RH0 Idle/Active	1	0	1	0	0	0
41	RH1 Idle/Active	1	0	1	0	0	1
42	Output of Op Amp0 in ACMP mode	1	0	1	0	1	0
43	Output of Op Amp1 in ACMP mode	1	0	1	0	1	1
44	IO0 Digital Input	1	0	1	1	0	0
45	IO1 Digital Input	1	0	1	1	0	1
46	IO2 Digital Input	1	0	1	1	1	0
47	IO3 Digital Input	1	0	1	1	1	1
48	IO4 Digital Input	1	1	0	0	0	0
49	IO5 Digital Input	1	1	0	0	0	1
50	IO6 Digital Input	1	1	0	0	1	0
51	I0 Digital Input	1	1	0	0	1	1
52	Oscillator0 output 0	1	1	0	1	0	0
53	Oscillator1 output 0	1	1	0	1	0	1
54	Oscillator2 output	1	1	0	1	1	0
55	Chopper ACMP Out	1	1	0	1	1	1
56	ACMP0 Output (low speed)	1	1	1	0	0	0
57	ACMP1 Output (low speed)	1	1	1	0	0	1
58	Oscillator0 output 1	1	1	1	0	1	0
59	Oscillator1 output 1	1	1	1	0	1	1
60	POR OUT	1	1	1	1	0	0
61	V _{DD}	1	1	1	1	0	1
62	V _{DD}	1	1	1	1	1	0
63	V _{DD}	1	1	1	1	1	1

6.2 MATRIX OUTPUT TABLE

Table 28: Matrix Output Table

Register Bit Address	Matrix Output Signal Function	Matrix Output Number
[5:0]	IN0 of 2-bit LUT0 or Clock Input of DFF0	0
[11:6]	IN1 of 2-bit LUT0 or Data Input of DFF0	1
[17:12]	IN0 of 2-bit LUT1 or Clock Input of DFF1	2
[23:18]	IN1 of 2-bit LUT1 or Data Input of DFF1	3
[29:24]	IN0 of 2-bit LUT2 or Clock Input of DFF2	4
[35:30]	IN1 of 2-bit LUT2 or Data Input of DFF2	5
[41:36]	IN0 of 2-bit LUT3 or Clock Input of PGen	6
[47:42]	IN1 of 2-bit LUT3 or nRST of PGen	7
[53:48]	IN0 of 3-bit LUT0 or CLK Input of DFF3	8

Table 28: Matrix Output Table(Continued)

Register Bit Address	Matrix Output Signal Function	Matrix Output Number
[59:54]	IN1 of 3-bit LUT0 or Data of DFF3	9
[65:60]	IN2 of 3-bit LUT0 or nRST (nSET) of DFF3	10
[71:66]	IN0 of 3-bit LUT1 or CLK Input of DFF4	11
[77:72]	IN1 of 3-bit LUT1 or Data of DFF4	12
[83:78]	IN2 of 3-bit LUT1 or nRST (nSET) of DFF4	13
[89:84]	IN0 of 3-bit LUT2 or CLK Input of DFF5	14
[95:90]	IN1 of 3-bit LUT2 or Data of DFF5	15
[101:96]	IN2 of 3-bit LUT2 or nRST(nSET) of DFF5	16
[107:102]	IN0 of 3-bit LUT3 or CLK Input of DFF6	17
[113:108]	IN1 of 3-bit LUT3 or Data of DFF6	18
[119:114]	IN2 of 3-bit LUT3 or nRST (nSET) of DFF6	19
[125:120]	IN0 of 3-bit LUT4 or CLK Input of DFF7	20
[131:126]	IN1 of 3-bit LUT4 or Data of DFF7	21
[137:132]	IN2 of 3-bit LUT4 or nRST (nSET) of DFF7	22
[143:138]	IN0 of 3-bit LUT5 or CLK Input of DFF8	23
[149:144]	IN1 of 3-bit LUT5 or Data of DFF8	24
[155:150]	IN2 of 3-bit LUT5 or nRST (nSET) of DFF8	25
[161:156]	IN0 of 3-bit LUT6 or CLK Input of DFF9	26
[167:162]	IN1 of 3-bit LUT6 or CLK Input of DFF9	27
[173:168]	IN2 of 3-bit LUT6 or nRST (nSET) of DFF9	28
[179:174]	IN0 of 3-bit LUT7 or CLK Input of DFF11 Delay1 Input (or Counter1 nRST Input)	29
[185:180]	IN1 of 3-bit LUT7 or nRST (nSET) of DFF11 Delay1 Input (or Counter1 nRST Input)	30
[191:186]	IN2 of 3-bit LUT7 or Data of DFF11 Delay1 Input (or Counter1 nRST Input)	31
[197:192]	IN0 of 3-bit LUT8 or CLK Input of DFF12 Delay2 Input (or Counter2 nRST Input)	32
[203:198]	IN1 of 3-bit LUT8 or nRST (nSET) of DFF12 Delay2 Input (or Counter2 nRST Input)	33
[209:204]	IN2 of 3-bit LUT8 or Data of DFF12 Delay2 Input (or Counter2 nRST Input)	34
[215:210]	IN0 of 3-bit LUT9 or CLK Input of DFF13 Delay3 Input (or Counter3 nRST Input)	35
[221:216]	IN1 of 3-bit LUT9 or nRST (nSET) of DFF13 Delay3 Input (or Counter3 nRST Input)	36
[227:222]	IN2 of 3-bit LUT9 or Data of DFF13 Delay3 Input (or Counter3 nRST Input)	37
[233:228]	IN0 of 3-bit LUT10 or CLK Input of DFF14 Delay4 Input (or Counter4 nRST Input)	38
[239:234]	IN1 of 3-bit LUT10 or nRST (nSET) of DFF14 Delay4 Input (or Counter4 nRST Input)	39

Table 28: Matrix Output Table(Continued)

Register Bit Address	Matrix Output Signal Function	Matrix Output Number
[245:240]	IN2 of 3-bit LUT10 or Data of DFF14 Delay4 Input (or Counter4 nRST Input)	40
[251:246]	IN0 of 3-bit LUT11 or CLK Input of DFF15 Delay5 Input (or Counter5 nRST Input)	41
[257:252]	IN1 of 3-bit LUT11 or nRST (nSET) of DFF15 Delay5 Input (or Counter5 nRST Input)	42
[263:258]	IN2 of 3-bit LUT11 or nRST (nSET) of DFF15 Delay5 Input (or Counter5 nRST Input)	43
[269:264]	IN0 of 3-bit LUT12 or CLK Input of DFF16 Delay6 Input (or Counter6 nRST Input)	44
[275:270]	IN1 of 3-bit LUT12 or nRST (nSET) of DFF16 Delay6 Input (or Counter6 nRST Input)	45
[281:276]	IN2 of 3-bit LUT12 or Data of DFF16 Delay6 Input (or Counter6 nRST Input)	46
[287:282]	IN0 of 3-bit LUT13 or Input of Pipe Delay or UP signal of RIPP CNT	47
[293:288]	IN1 of 3-bit LUT13 or nRST of Pipe Delay or nSet of RIPP CNT	48
[299:294]	IN2 of 3-bit LUT13 or CLK of Pipe Delay_RIPP CNT	49
[305:300]	IN0 of 4-bit LUT0 or CLK of DFF10	50
[311:306]	IN1 of 4-bit LUT0 or Data of DFF10	51
[317:312]	IN2 of 4-bit LUT0 or nRST (nSET) of DFF10	52
[323:318]	IN3 of 4-bit LUT0	53
[329:324]	IN0 of 4-bit LUT1 or CLK Input of DFF17 Delay0 Input (or Counter0 nRST Input)	54
[335:330]	IN1 of 4-bit LUT1 or nRST of DFF17 Delay0 Input (or Counter0 nRST Input) Delay/Counter0 External CLK source	55
[341:336]	IN2 of 4-bit LUT1 or nSet of DFF17 Delay0 Input (or Counter0 nRST Input) Delay/Counter0 External CLK source KEEP Input of FSM0	56
[347:342]	IN3 of 4-bit LUT1 or Data of DFF17 Delay0 Input (or Counter0 nRST Input) UP Input of FSM0	57
[353:348]	Programmable delay/edge detect input	58
[359:354]	Filter/Edge detect input	59
[365:360]	IO0 DOUT	60
[371:366]	IO0 DOUT OE	61
[377:372]	IO1 DOUT	62
[383:378]	IO1 DOUT OE	63
[389:384]	IO2 DOUT	64
[395:390]	IO2 DOUT OE	65
[401:396]	IO3 DOUT	66
[407:402]	IO3 DOUT OE	67
[413:408]	IO4 DOUT	68

Table 28: Matrix Output Table(Continued)

Register Bit Address	Matrix Output Signal Function	Matrix Output Number
[419:414]	IO4 DOUT OE	69
[425:420]	IO5 DOUT	70
[431:426]	IO5 DOUT OE	71
[437:432]	IO6 DOUT	72
[443:438]	IO6 DOUT OE	73
[449:444]	Set of PT0 block	74
[455:450]	Clock of PT0 block	75
[461:456]	Reload of PT0 block	76
[467:462]	Program of PT0 block	77
[473:468]	Up/Down of PT0 block	78
[479:474]	Set of PT1 block	79
[485:480]	Clock of PT1 block	80
[491:486]	Reload of PT1 block	81
[497:492]	Program of PT1 block	82
[503:498]	Up/Down of PT1 block	83
[509:504]	FIFO Reset of PT blocks	84
[515:510]	Power Up of Chopper ACMP	85
[521:516]	Rheostats Charge Pump Enable	86
[527:522]	ASW0 enable/Half bridge Enable	87
[533:528]	ASW1 enable/Half bridge data	88
[539:534]	ACMP0 Power Up	89
[545:540]	ACMP1 Power Up	90
[551:546]	Oscillator0 Enable	91
[557:552]	Oscillator1 Enable	92
[563:558]	Oscillator2 Enable	93
[569:564]	VrefO, Temp sensor, VrefO Power Up	94
[575:570]	HDBUF Enable	95
[581:576]	Op Amp0 Power Up	96
[587:582]	Op Amp1 Power Up	97
[593:588]	Op Amp2 Power Up	98
[599:594]	Op amps Vref Enable	99

Note 1 For each Address, the two most significant bits are unused.

6.3 CONNECTION MATRIX VIRTUAL INPUTS

As mentioned previously, the Connection Matrix inputs come from the outputs of various digital macrocells on the device. Eight of the Connection Matrix inputs have the special characteristic that the state of these signal lines comes from a corresponding data bit written as a register value via I²C. This gives the user the ability to write data via the serial channel, and have this information translated into signals that can be driven into the Connection Matrix and from the Connection Matrix to the digital inputs of other macrocells on the device. The I²C address for reading and writing these register values is at 0x7C (124).

An I²C write command to these register bits will set the signal values going into the Connection Matrix to the desired state. A read command to these register bits will read either the original data values coming from the NVM memory bits (that were

SLG47004

GreenPAK Programmable Mixed-Signal Matrix with In-System Programmability and Advanced Analog Features

loaded during the initial device startup), or the values from a previous write command (if that has happened).

See [Table 29](#).

Table 29: Connection Matrix Virtual Inputs

Matrix Input Number	Matrix Input Signal Function	Register Bit Addresses (d)
32	I ² C_virtual_0 Input	[992]
33	I ² C_virtual_1 Input	[993]
34	I ² C_virtual_2 Input	[994]
35	I ² C_virtual_3 Input	[995]
36	I ² C_virtual_4 Input	[996]
37	I ² C_virtual_5 Input	[997]
38	I ² C_virtual_6 Input	[998]
39	I ² C_virtual_7 Input	[999]

6.4 CONNECTION MATRIX VIRTUAL OUTPUTS

The digital outputs of the various macrocells are routed to the Connection Matrix to enable interconnections to the inputs of other macrocells in the device. At the same time, it is possible to read the state of each of the macrocell outputs as a register value via I²C. This option, called Connection Matrix Virtual Outputs, allows the user to remotely read the values of each macrocell output. The I²C addresses for reading these register values are bytes 0xC4 (196) to 0xCA (202). Write commands to these same register values will be ignored (with the exception of the Virtual Input register bits at byte 0x7C (124)).

SLG47004

GreenPAK Programmable Mixed-Signal Matrix with In-System Programmability and Advanced Analog Features

7 Combination Function Macrocells

The SLG47004 has 13 combination function macrocells that can serve as more than one logic or timing function. In each case, they can serve as a Look Up Table (LUT), or as another logic or timing function. See the list below for the functions that can be implemented in these macrocells:

- Three macrocells that can serve as either 2-bit LUT or as D Flip-Flop
- Seven macrocells that can serve as either 3-bit LUTs or as D Flip-Flops with Set/Reset Input
- One macrocell that can serve as either 3-bit LUT or as Pipe Delay/Ripple Counter
- One macrocell that can serve as either 2-bit LUT or as Programmable Pattern Generator (PGen)
- One macrocell that can serve as either 4-bit LUT or as D Flip-Flop with Set/Reset Input

Inputs/Outputs for the 13 combination function macrocells are configured from the connection matrix with specific logic functions being defined by the state of configuration bits.

When used as a LUT to implement combinatorial logic functions, the outputs of the LUTs can be configured to any user-defined function, including the following standard digital logic devices (AND, NAND, OR, NOR, XOR, XNOR).

7.1 2-BIT LUT OR D FLIP-FLOP MACROCELLS

There is one macrocell that can serve as either 2-bit LUT or as D Flip-Flop. When used to implement LUT functions, the 2-bit LUT takes in two input signals from the connection matrix and produces a single output, which goes back into the connection matrix. When used to implement D Flip-Flop function, the two input signals from the connection matrix go to the data (D) and clock (CLK) inputs for the Flip-Flop, with the output going back to the connection matrix.

The operation of the D Flip-Flop and LATCH will follow the functional descriptions below:

DFF: CLK is rising edge triggered, then Q = D; otherwise Q will not change.

LATCH: when CLK is Low, then Q = D; otherwise Q remains its previous value (input D has no effect on the output, when CLK is High).

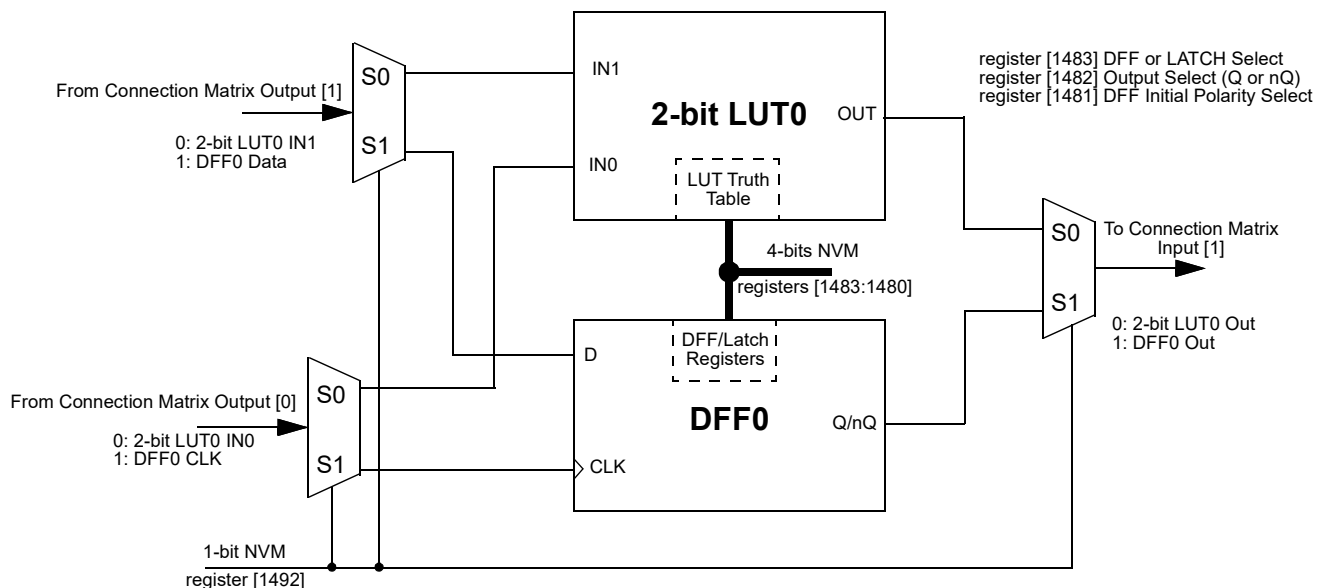

Figure 13: 2-bit LUT0 or DFF0

SLG47004

GreenPAK Programmable Mixed-Signal Matrix with In-System Programmability and Advanced Analog Features

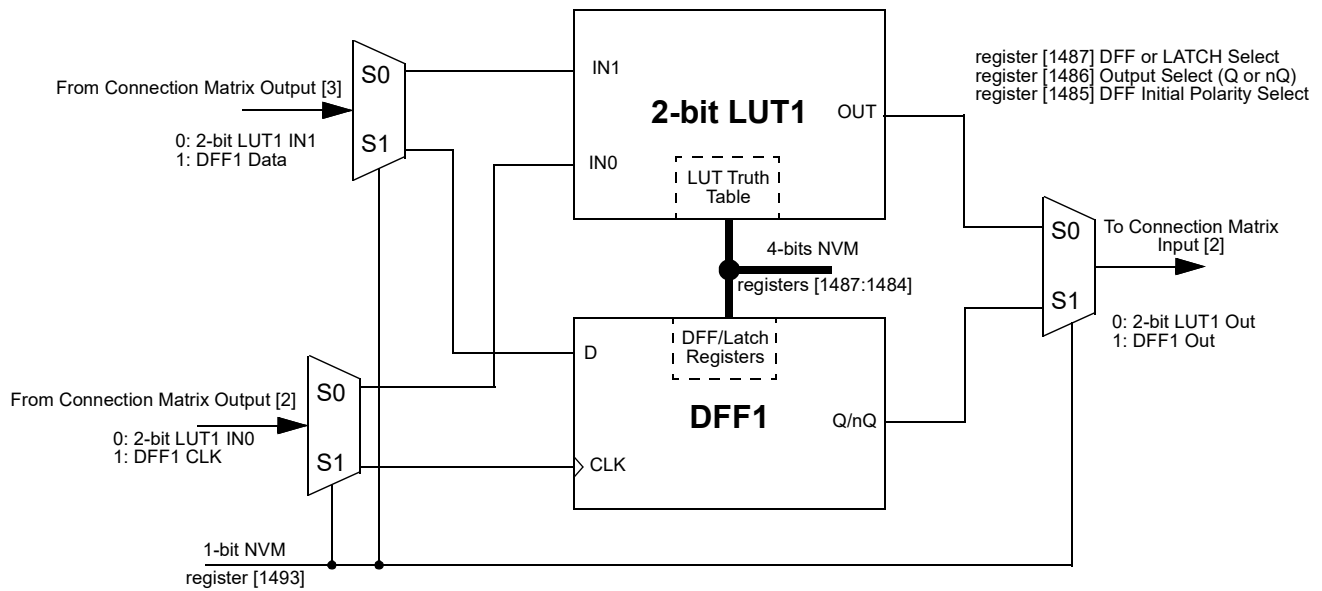

Figure 14: 2-bit LUT1 or DFF1

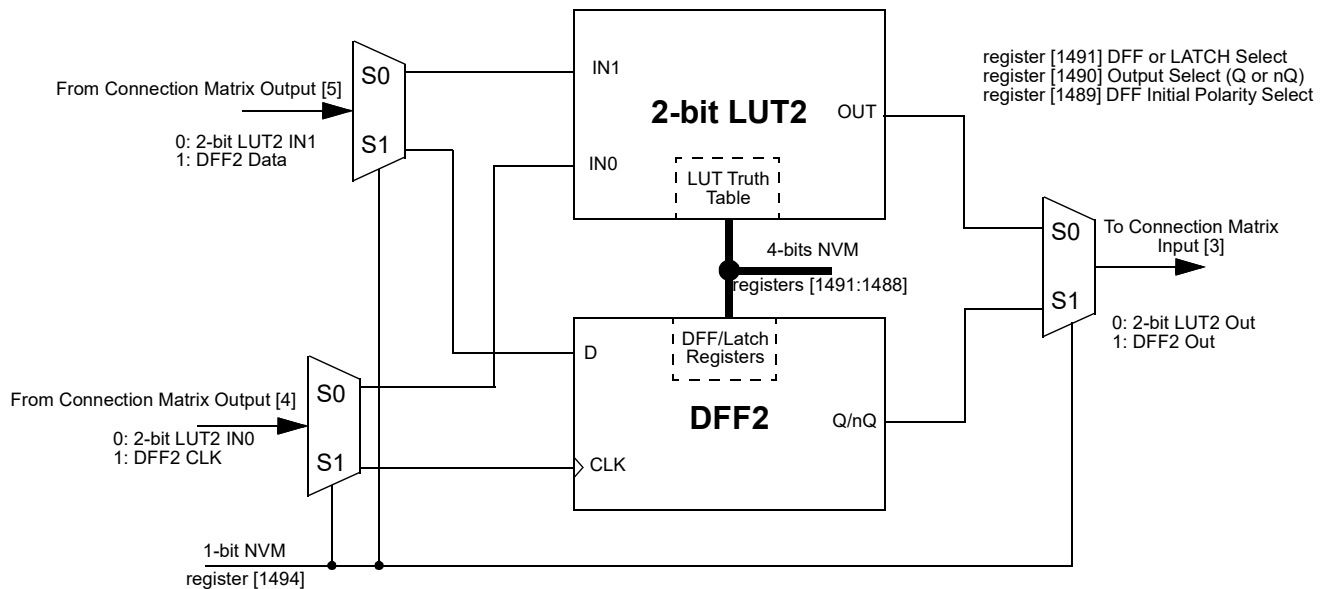

Figure 15: 2-bit LUT2 or DFF2

7.1.1 2-Bit LUT or D Flip-Flop Macrocell Used as 2-Bit LUT
Table 30: 2-bit LUT0 Truth Table

IN1	IN0	OUT	
0	0	register [1480]	LSB
0	1	register [1481]	
1	0	register [1482]	
1	1	register [1483]	MSB

Table 31: 2-bit LUT1 Truth Table

IN1	IN0	OUT	
0	0	register [1484]	LSB
0	1	register [1485]	
1	0	register [1486]	
1	1	register [1487]	MSB

Table 32: 2-bit LUT2 Truth Table

IN1	IN0	OUT	
0	0	register [1488]	LSB
0	1	register [1489]	
1	0	register [1490]	
1	1	register [1491]	MSB

This macrocell, when programmed for a LUT function, uses a 4-bit register to define their output function:

2-Bit LUT0 is defined by registers [1483:1480]

2-Bit LUT1 is defined by registers [1487:1484]

2-Bit LUT2 is defined by registers [1491:1488]

Table 33 shows the register bits for the standard digital logic devices (AND, NAND, OR, NOR, XOR, XNOR) that can be created within each of the 2-bit LUT logic cells.

Table 33: 2-bit LUT Standard Digital Functions

Function	MSB			LSB
AND-2	1	0	0	0
NAND-2	0	1	1	1
OR-2	1	1	1	0
NOR-2	0	0	0	1
XOR-2	0	1	1	0
XNOR-2	1	0	0	1

SLG47004

GreenPAK Programmable Mixed-Signal Matrix with In-System Programmability and Advanced Analog Features

7.1.2 Initial Polarity Operations

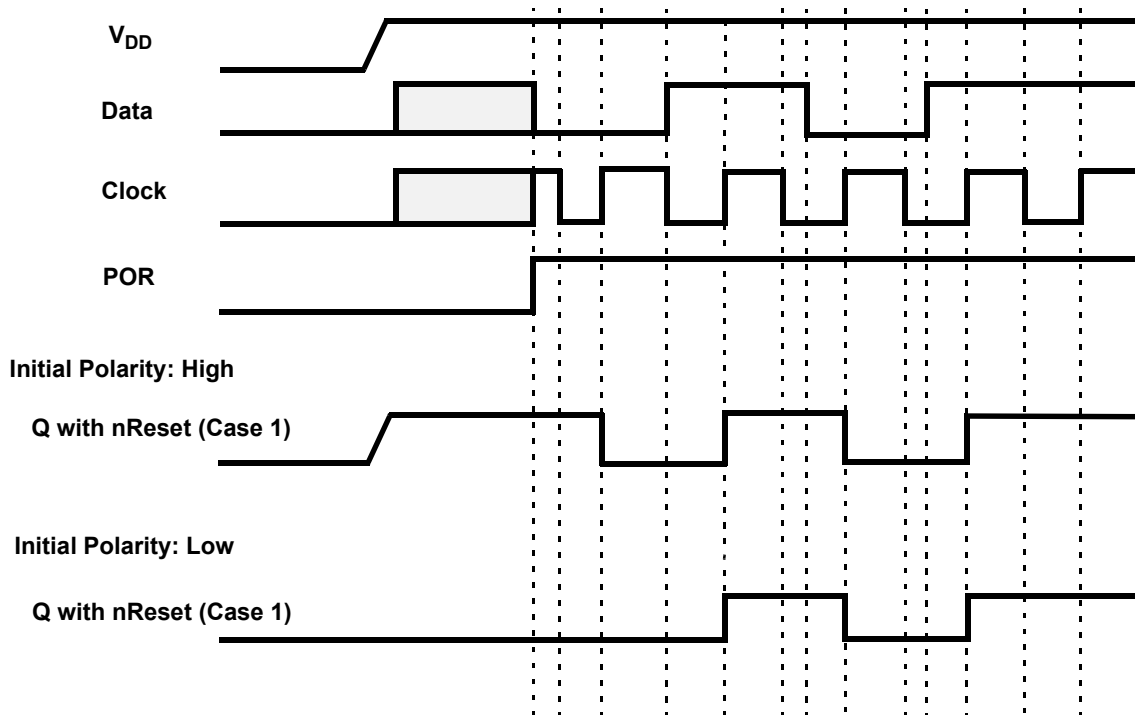

Figure 16: DFF Polarity Operations

7.2 2-BIT LUT OR PROGRAMMABLE PATTERN GENERATOR

The SLG47004 has one combination function macrocell that can serve as a logic or a timing function. This macrocell can serve as a Look Up Table (LUT), or a Programmable Pattern Generator (PGen).

When used to implement LUT functions, the 2-bit LUT takes in two input signals from the connection matrix and produces a single output, which goes back into the connection matrix. When used as a LUT to implement combinatorial logic functions, the outputs of the LUT can be configured to any user defined function, including the following standard digital logic devices (AND, NAND, OR, NOR, XOR, XNOR). The user can also define the combinatorial relationship between inputs and outputs to be any selectable function.

It is possible to define the RST level for the PGen macrocell. There are both high level reset (RST) and a low level reset (nRST) options available, which are selected by register [1517]. When operating as the Programmable Pattern Generator, the output of the macrocell will clock out a sequence of two to sixteen bits that are user selectable in their bit values, and user selectable in the number of bits (up to sixteen) that are output before the pattern repeats.

SLG47004

GreenPAK Programmable Mixed-Signal Matrix with In-System Programmability and Advanced Analog Features

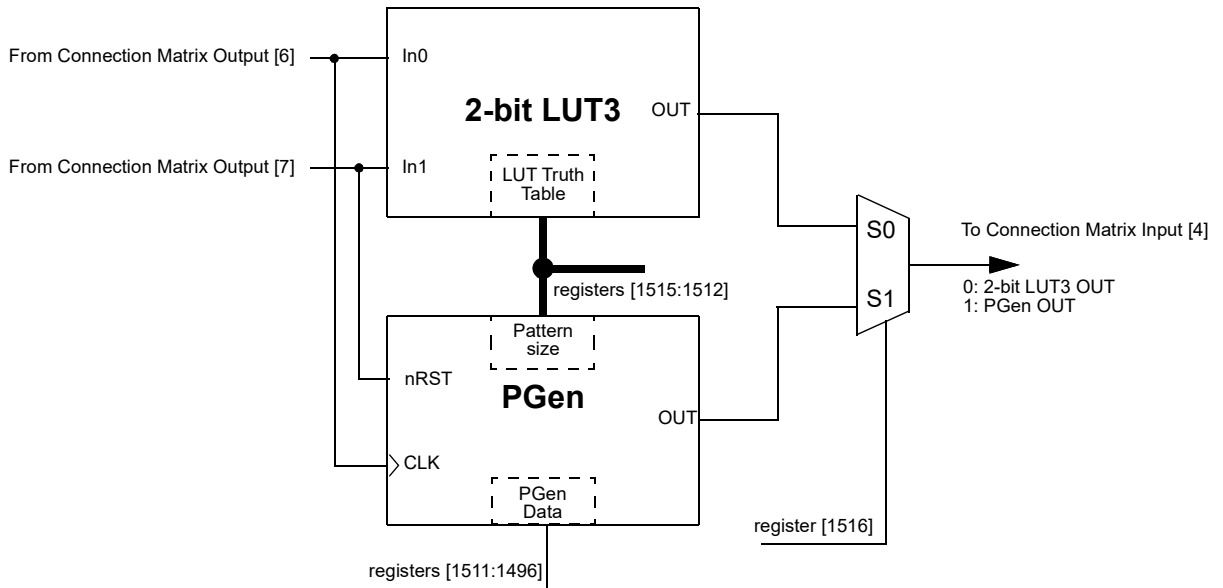

Figure 17: 2-bit LUT3 or PGen

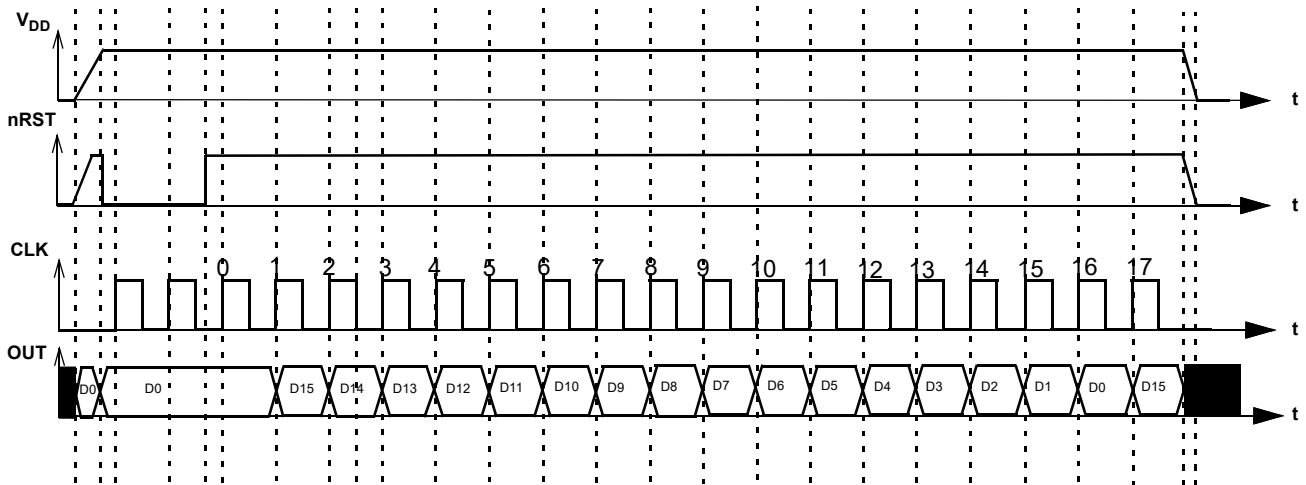

Figure 18: PGen Timing Diagram

SLG47004

GreenPAK Programmable Mixed-Signal Matrix with In-System Programmability and Advanced Analog Features

7.2.1 2-Bit LUT or PGen Macrocell Used as 2-Bit LUT

Table 34: 2-bit LUT1 Truth Table

IN1	IN0	OUT	
0	0	register [1512]	LSB
0	1	register [1513]	
1	0	register [1514]	
1	1	register [1515]	MSB

This macrocell, when programmed for a LUT function, uses a 4-bit register to define their output function:

2-Bit LUT3 is defined by [1515:1512]

Table 35 shows the register bits for the standard digital logic devices (AND, NAND, OR, NOR, XOR, XNOR) that can be created within each of the 2-bit LUT logic cells.

Table 35: 2-bit LUT Standard Digital Functions

Function	MSB			LSB
AND-2	1	0	0	0
NAND-2	0	1	1	1
OR-2	1	1	1	0
NOR-2	0	0	0	1
XOR-2	0	1	1	0
XNOR-2	1	0	0	1

7.3 3-BIT LUT OR D FLIP-FLOP WITH SET/RESET MACROCELLS

There are seven macrocells that can serve as either 3-bit LUTs or as D Flip-Flops with Set/Reset inputs. When used to implement LUT functions, the 3-bit LUTs each takes in three input signals from the connection matrix and produces a single output, which goes back into the connection matrix. When used to implement D Flip-Flop function, the three input signals from the connection matrix go to the data (D) and clock (CLK), and Reset/Set (nRST/nSET) inputs for the Flip-Flop, with the output going back to the connection matrix. It is possible to define the active level for the reset/set input of DFF/LATCH macrocell. There are both active high level reset/set (RST/SET) and active low level reset/set (nRST/nSET) options available, which are selected by register [1523].

The DFF3 operation will flow the functional description:

- If register [1522] = 0, and the CLK is rising edge triggered, then Q = D, otherwise Q will not change.
- If register [1522] = 1, then data from D is written into the DFF by the rising edge on CLK and output to Q by the falling edge on CLK.

SLG47004

GreenPAK Programmable Mixed-Signal Matrix with In-System Programmability and Advanced Analog Features

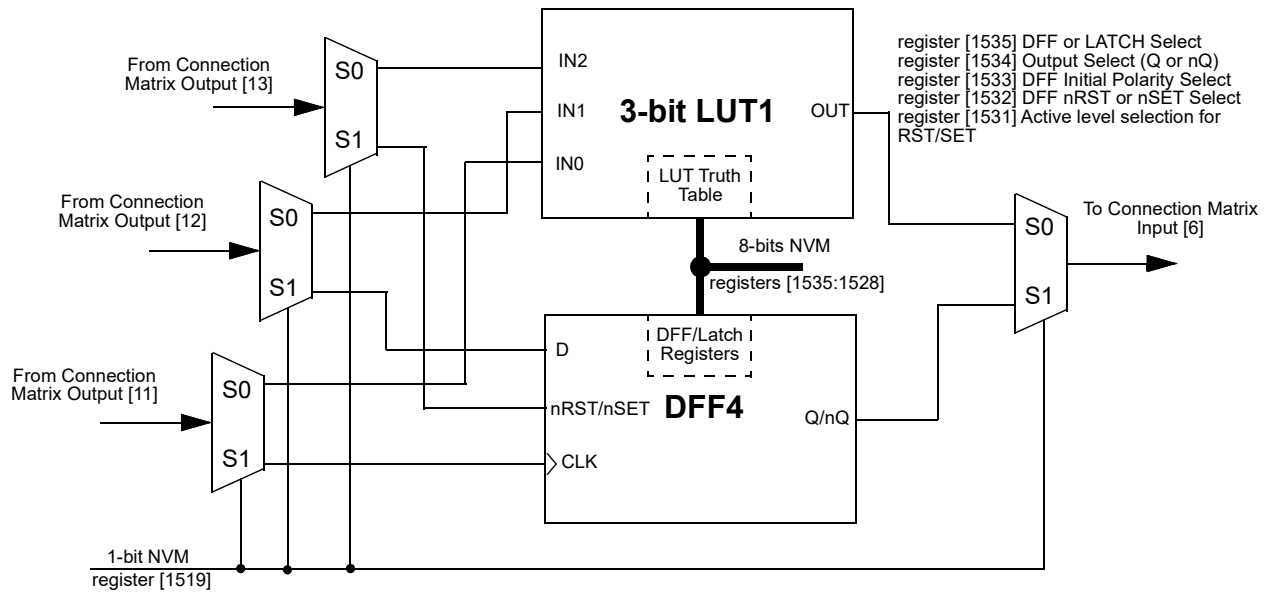

Figure 20: 3-bit LUT1 or DFF4

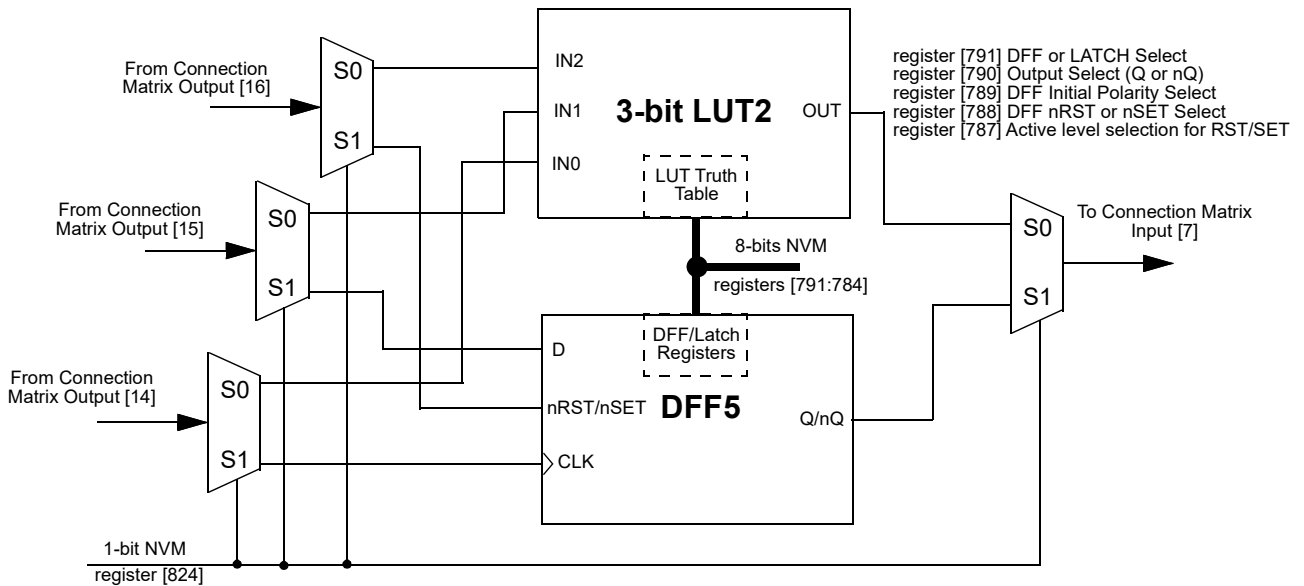

Figure 21: 3-bit LUT2 or DFF5

SLG47004

GreenPAK Programmable Mixed-Signal Matrix with In-System Programmability and Advanced Analog Features

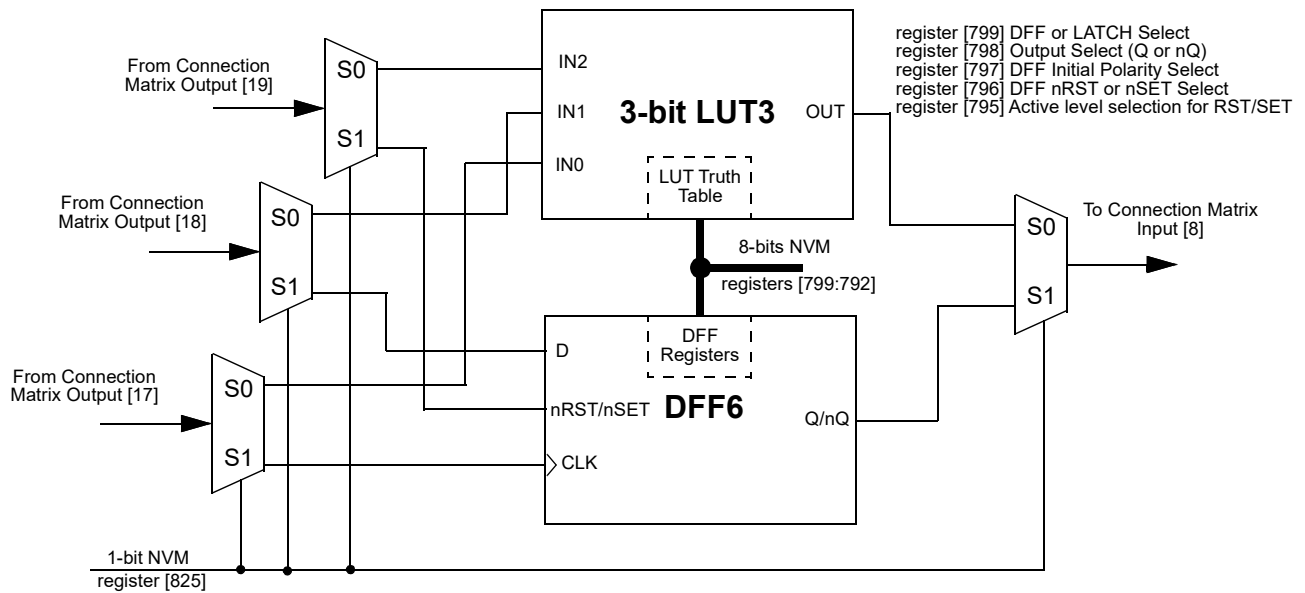

Figure 22: 3-bit LUT3 or DFF6

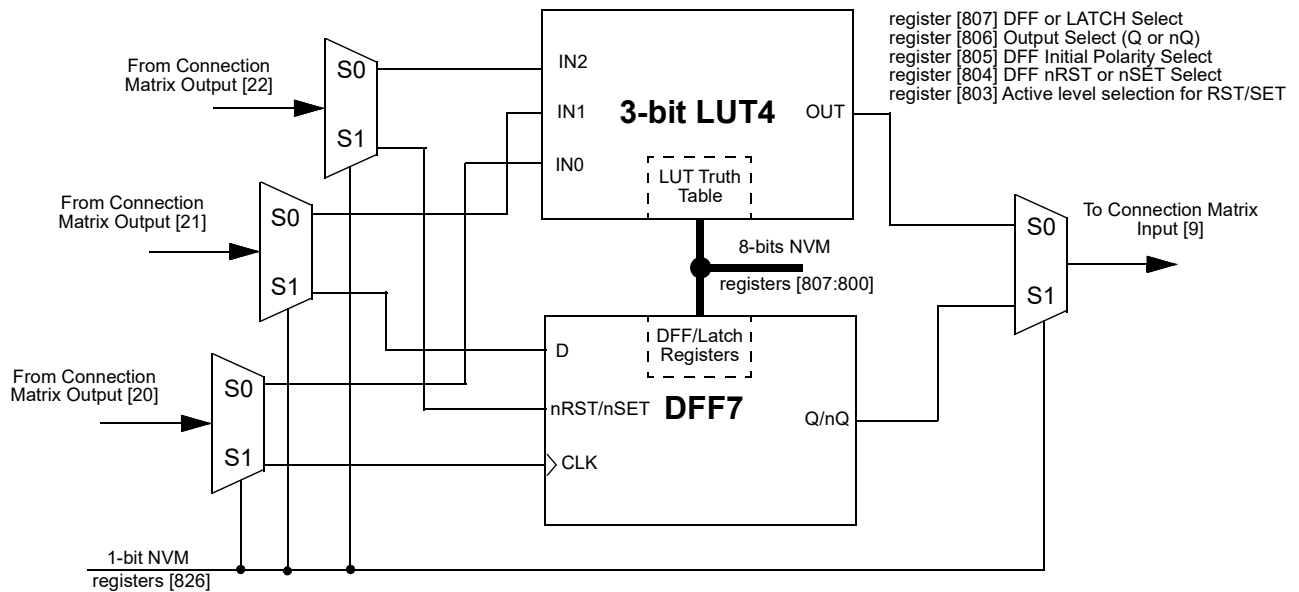

Figure 23: 3-bit LUT4 or DFF7

SLG47004

GreenPAK Programmable Mixed-Signal Matrix with In-System Programmability and Advanced Analog Features

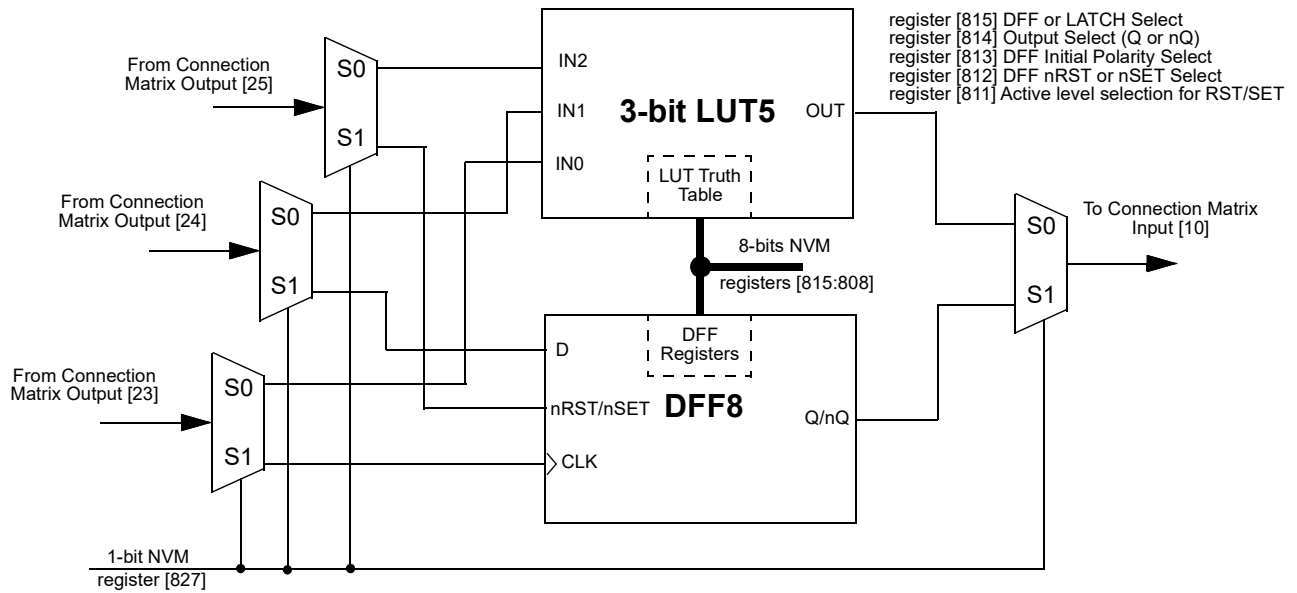

Figure 24: 3-bit LUT5 or DFF8

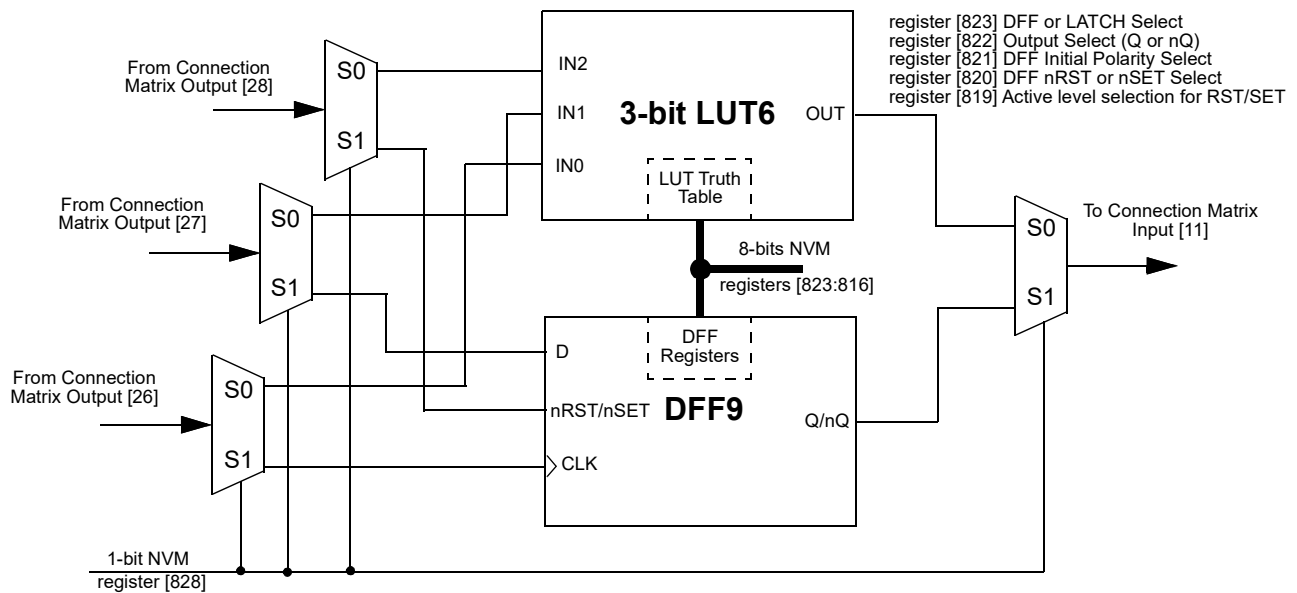

Figure 25: 3-bit LUT6 or DFF9

SLG47004

GreenPAK Programmable Mixed-Signal Matrix with In-System Programmability and Advanced Analog Features

7.3.1 3-Bit LUT or D Flip-Flop Macrocells Used as 3-Bit LUTs

Table 36: 3-bit LUT0 Truth Table

IN2	IN1	IN0	OUT	
0	0	0	register [1520]	LSB
0	0	1	register [1521]	
0	1	0	register [1522]	
0	1	1	register [1523]	
1	0	0	register [1524]	
1	0	1	register [1525]	
1	1	0	register [1526]	
1	1	1	register [1527]	MSB

Table 37: 3-bit LUT1 Truth Table

IN2	IN1	IN0	OUT	
0	0	0	register [1528]	LSB
0	0	1	register [1529]	
0	1	0	register [1530]	
0	1	1	register [1531]	
1	0	0	register [1532]	
1	0	1	register [1533]	
1	1	0	register [1534]	
1	1	1	register [1535]	MSB

Table 38: 3-bit LUT2 Truth Table

IN2	IN1	IN0	OUT	
0	0	0	register [784]	LSB
0	0	1	register [785]	
0	1	0	register [786]	
0	1	1	register [787]	
1	0	0	register [788]	
1	0	1	register [789]	
1	1	0	register [790]	
1	1	1	register [791]	MSB

Table 39: 3-bit LUT3 Truth Table

IN2	IN1	IN0	OUT	
0	0	0	register [792]	LSB
0	0	1	register [793]	
0	1	0	register [794]	
0	1	1	register [795]	
1	0	0	register [796]	
1	0	1	register [797]	
1	1	0	register [798]	
1	1	1	register [799]	MSB

Table 40: 3-bit LUT4 Truth Table

IN2	IN1	IN0	OUT	
0	0	0	register [800]	LSB
0	0	1	register [801]	
0	1	0	register [802]	
0	1	1	register [803]	
1	0	0	register [804]	
1	0	1	register [805]	
1	1	0	register [806]	
1	1	1	register [807]	MSB

Table 41: 3-bit LUT5 Truth Table

IN2	IN1	IN0	OUT	
0	0	0	register [808]	LSB
0	0	1	register [809]	
0	1	0	register [810]	
0	1	1	register [811]	
1	0	0	register [812]	
1	0	1	register [813]	
1	1	0	register [814]	
1	1	1	register [815]	MSB

Table 42: 3-bit LUT6 Truth Table

IN2	IN1	IN0	OUT	
0	0	0	register [816]	LSB
0	0	1	register [817]	
0	1	0	register [818]	
0	1	1	register [819]	
1	0	0	register [820]	
1	0	1	register [821]	
1	1	0	register [822]	
1	1	1	register [823]	MSB

SLG47004

GreenPAK Programmable Mixed-Signal Matrix with In-System Programmability and Advanced Analog Features

Each macrocell, when programmed for a LUT function, uses an 8-bit register to define their output function:

3-Bit LUT0 is defined by registers [1527:1520]

3-Bit LUT1 is defined by registers [1535:1528]

3-Bit LUT2 is defined by registers [791:784]

3-Bit LUT3 is defined by registers [799:792]

3-Bit LUT4 is defined by registers [807:800]

3-Bit LUT5 is defined by registers [815:808]

3-Bit LUT6 is defined by registers [823:816]

Table 43 shows the register bits for the standard digital logic devices (AND, NAND, OR, NOR, XOR, XNOR) that can be created within each of the four 3-bit LUT logic cells.

Table 43: 3-bit LUT Standard Digital Functions

Function	MSB							LSB
AND-3	1	0	0	0	0	0	0	0
NAND-3	0	1	1	1	1	1	1	1
OR-3	1	1	1	1	1	1	1	0
NOR-3	0	0	0	0	0	0	0	1
XOR-3	1	0	0	1	0	1	1	0
XNOR-3	0	1	1	0	1	0	0	1

SLG47004

GreenPAK Programmable Mixed-Signal Matrix
with In-System Programmability and Advanced Analog Features

7.3.2 Initial Polarity Operations

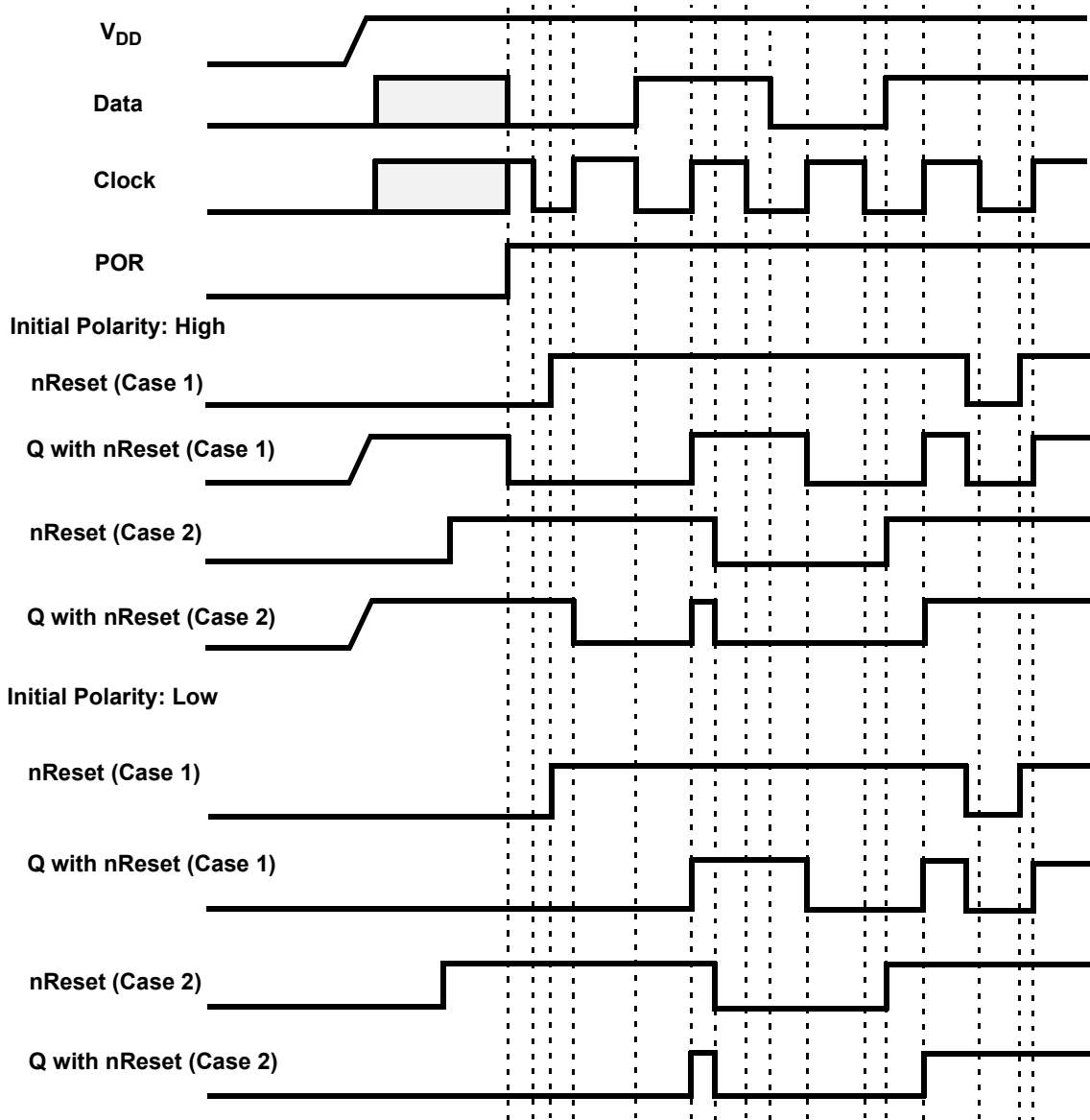

Figure 26: DFF Polarity Operations with nReset

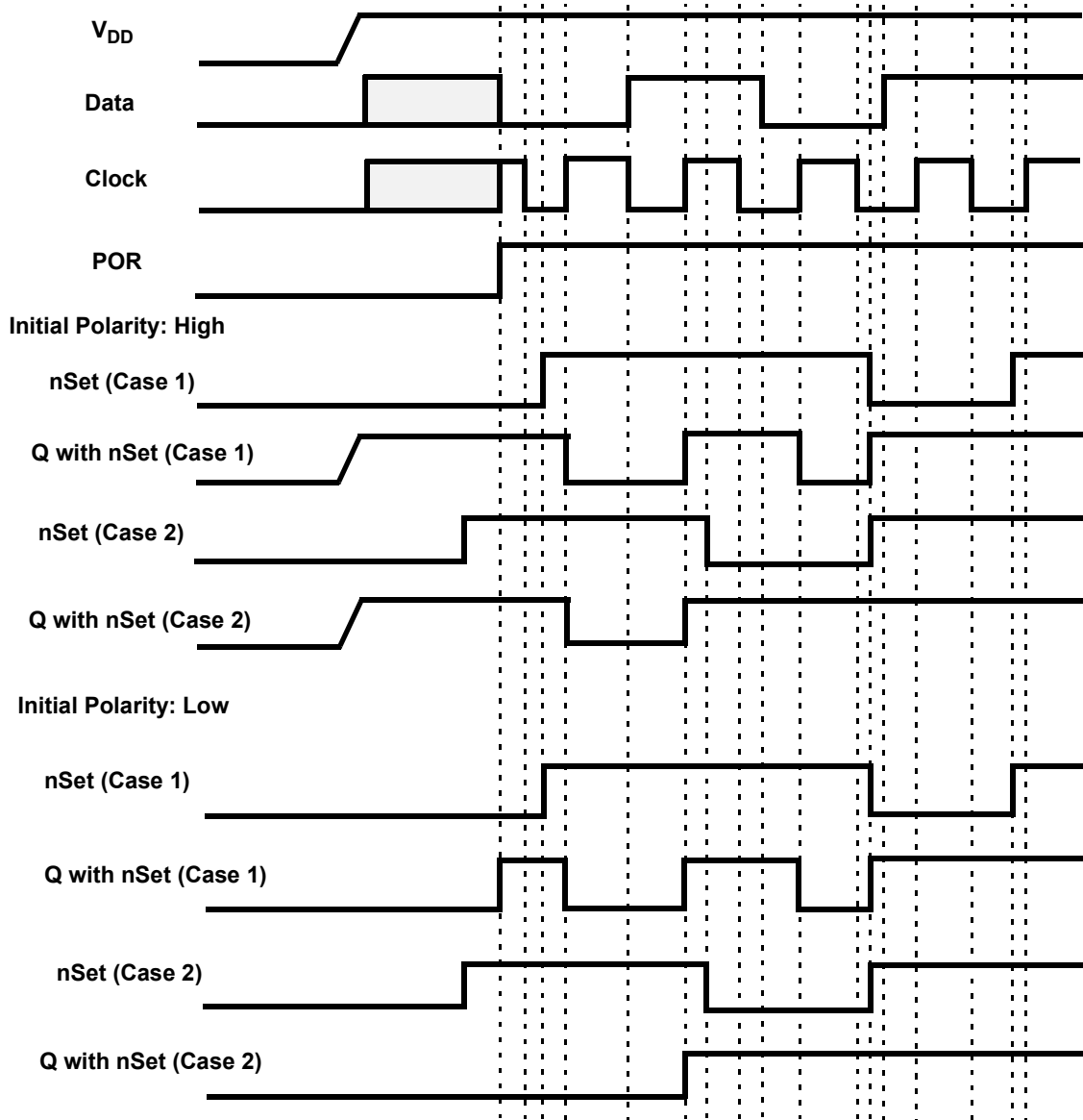

Figure 27: DFF Polarity Operations with nSet

7.4 4-BIT LUT OR D FLIP-FLOP WITH SET/RESET MACROCELL

There is one macrocell that can serve as either a 4-bit LUT or as a D Flip-Flop with Set/Reset inputs. When used to implement LUT functions, the 4-bit LUT takes in four input signals from the connection matrix and produces a single output, which goes back into the connection matrix. When used to implement D Flip-Flop function, the input signals from the connection matrix go to the data (D) and clock (CLK), and Reset/Set (nRST/nSET) inputs for the Flip-Flop, with the output going back to the connection matrix.

If register [842] = 0, and the CLK is rising edge triggered, then Q = D, otherwise Q will not change.

If register [842] = 1, then data from D is written into the DFF by the rising edge on CLK and output to Q by the falling edge on CLK. It is possible to define the active level for the reset/set input of DFF/LATCH macrocell. There are both active high level reset/set (RST/SET) and active low level reset/set (nRST/nSET) options available, which are selected by register [843].

SLG47004

GreenPAK Programmable Mixed-Signal Matrix with In-System Programmability and Advanced Analog Features

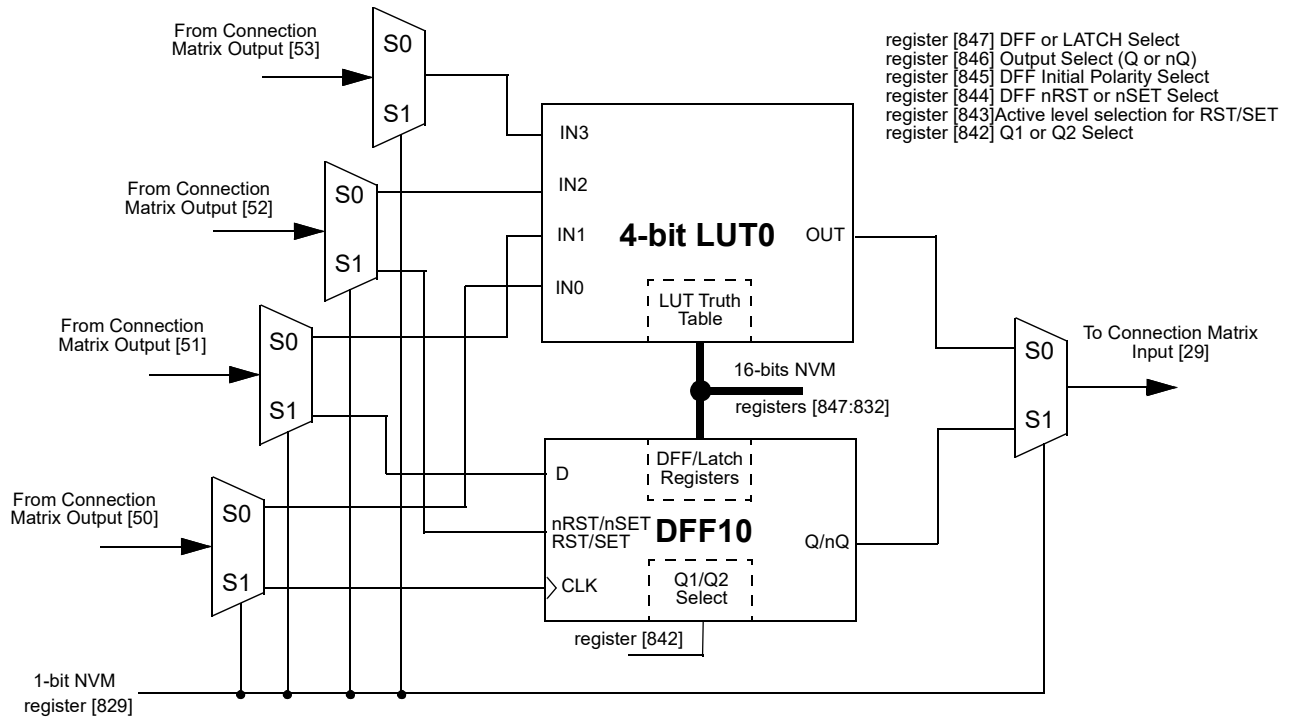

Figure 28: 4-bit LUT0 or DFF10

7.4.1 4-Bit LUT Macrocell Used as 4-Bit LUT

Table 44: 4-bit LUT0 Truth Table

IN3	IN2	IN1	IN0	OUT	
0	0	0	0	register [832]	LSB
0	0	0	1	register [833]	
0	0	1	0	register [834]	
0	0	1	1	register [835]	
0	1	0	0	register [836]	
0	1	0	1	register [837]	
0	1	1	0	register [838]	
0	1	1	1	register [839]	
1	0	0	0	register [840]	
1	0	0	1	register [841]	
1	0	1	0	register [842]	
1	0	1	1	register [843]	
1	1	0	0	register [844]	
1	1	0	1	register [845]	
1	1	1	0	register [846]	
1	1	1	1	register [847]	MSB

SLG47004

GreenPAK Programmable Mixed-Signal Matrix with In-System Programmability and Advanced Analog Features

This macrocell, when programmed for a LUT function, uses a 16-bit register to define their output function:

4-Bit LUT0 is defined by registers [847:832]

Table 45: 4-bit LUT Standard Digital Functions

Function	MSB															LSB
AND-4	1	0	0	0	0	0	0	0	0	0	0	0	0	0	0	0
NAND-4	0	1	1	1	1	1	1	1	1	1	1	1	1	1	1	1
OR-4	1	1	1	1	1	1	1	1	1	1	1	1	1	1	1	0
NOR-4	0	0	0	0	0	0	0	0	0	0	0	0	0	0	0	1
XOR-4	0	1	1	0	1	0	0	1	1	0	0	1	0	1	1	0
XNOR-4	1	0	0	1	0	1	1	0	0	1	1	0	1	0	0	1

7.5 3-BIT LUT OR PIPE DELAY/RIPPLE COUNTER MACROCELL

There is one macrocell that can serve as either a 3-bit LUT or as a Pipe Delay/Ripple Counter.

When used to implement LUT functions, the 3-bit LUT takes in three input signals from the connection matrix and produces a single output, which goes back into the connection matrix.

When used as a Pipe Delay, there are three inputs signals from the matrix, Input (IN), Clock (CLK), and Reset (nRST). The Pipe Delay cell is built from 16 D Flip-Flop logic cells that provide the three delay options, two of which are user selectable. The DFF cells are tied in series where the output (Q) of each delay cell goes to the next DFF cell input (IN). Both of the two outputs (OUT0 and OUT1) provide user selectable options for 1 to 16 stages of delay. There are delay output points for each set of the OUT0 and OUT1 outputs to a 4-input mux that is controlled by registers [851:848] for OUT0 and registers [855:852] for OUT1. The 4-input MUX is used to control the selection of the amount of delay.

The overall time of the delay is based on the clock used in the SLG47004 design. Each DFF cell has a time delay of the inverse of the clock time (either external clock or the internal Oscillator within the SLG47004). The sum of the number of DFF cells used will be the total time delay of the Pipe Delay logic cell. OUT1 Output can be inverted (as selected by register [859]).

In the Ripple Counter mode, there are 3 options for setting, which use 7 bits. There are 3 bits to set **nSET value (SV)** in range from 0 to 7. It is a value, which will be set into the Ripple Counter outputs when nSET input goes LOW. **End value (EV)** will use 3 bits for setting outputs code, which will be last code in the cycle. After reaching the EV, the Ripple Counter goes to the first code by the rising edge on CLK input. The **Functionality mode** option uses 1 bit. This setting defines how exactly Ripple Counter will operate.

The user can select one of the functionality modes by register: RANGE or FULL. If the RANGE option is selected, the count starts from SV. If UP input is LOW the count goes down: SV→EV→EV-1 to SV+1→SV, and others (if SV is smaller than EV), or SV→SV-1 to EV+1→EV→SV (if SV is bigger than EV). If UP input is HIGH, count starts from SV up to EV, and others.

In the FULL range configuration the Ripple Counter functions as follows. If UP input is LOW, the count starts from SV and goes down to 0. Then current counter value jumps to EV and goes down to 0, and others.

If UP input is HIGH, count goes up starting from SV. Then current counter value jumps to 0 and counts up to EV, and others. See Ripple Counter functionality example in [Figure 30](#).

Every step is executed by the rising edge on CLK input.

SLG47004

GreenPAK Programmable Mixed-Signal Matrix
with In-System Programmability and Advanced Analog Features

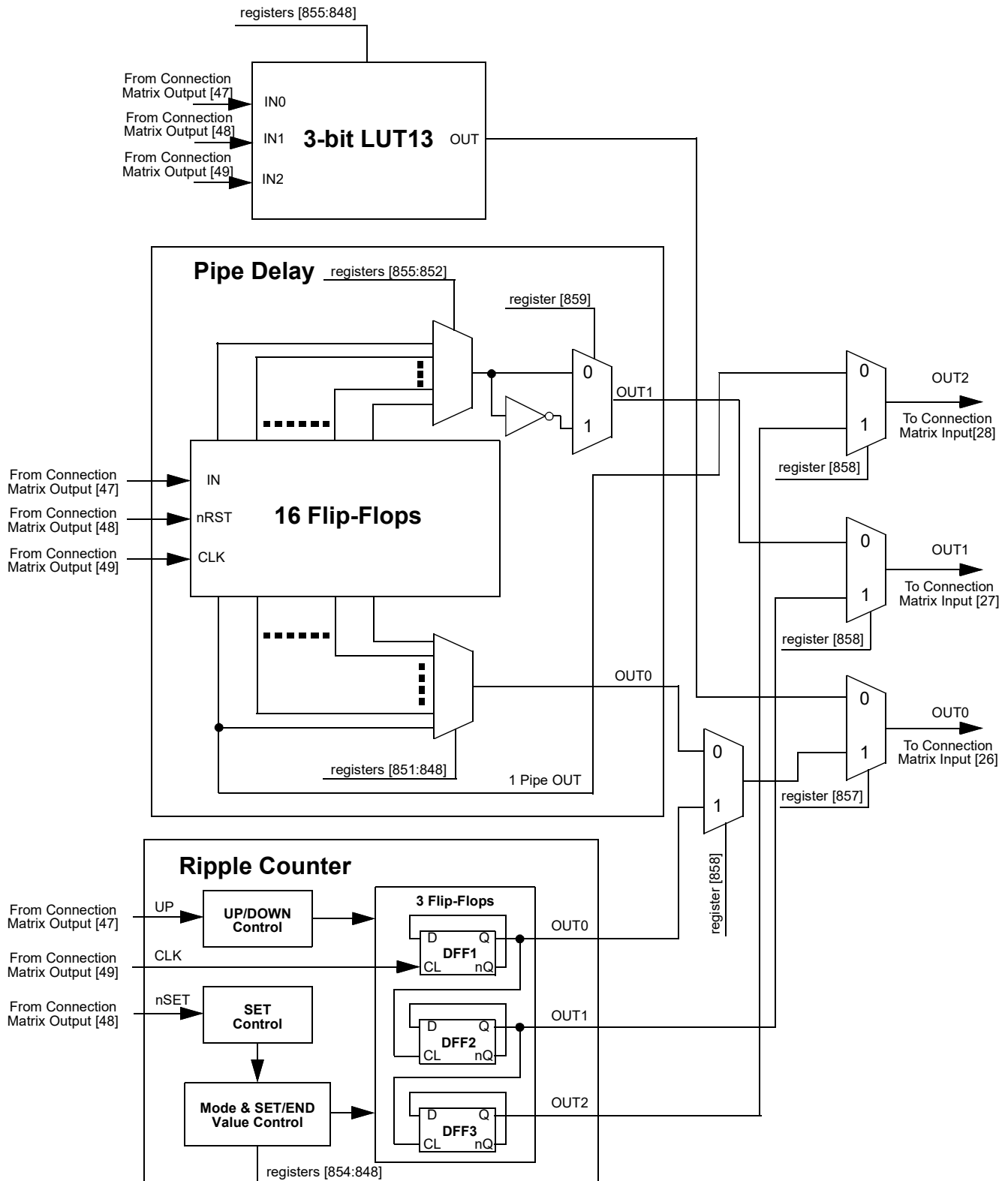

Figure 29: 3-bit LUT13/Pipe Delay/Ripple Counter

SLG47004

GreenPAK Programmable Mixed-Signal Matrix with In-System Programmability and Advanced Analog Features

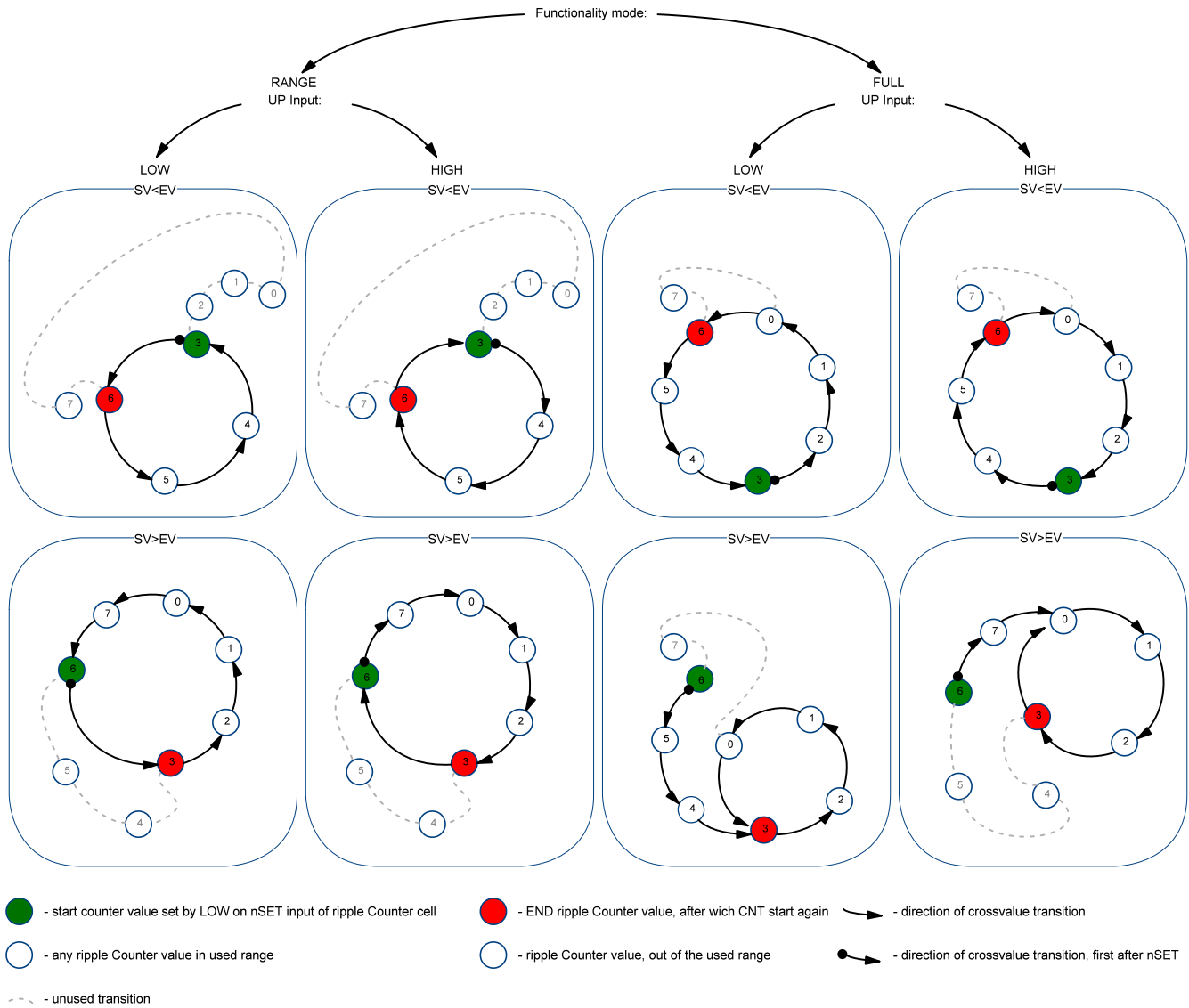

Figure 30: Example: Ripple Counter Functionality

7.5.1 3-Bit LUT or Pipe Delay Macrocells Used as 3-Bit LUT

Table 46: 3-bit LUT13 Truth Table

IN2	IN1	IN0	OUT
0	0	0	register [848]
0	0	1	register [849]
0	1	0	register [850]
0	1	1	register [851]
1	0	0	register [852]
1	0	1	register [853]
1	1	0	register [854]
1	1	1	register [855]

SLG47004

GreenPAK Programmable Mixed-Signal Matrix with In-System Programmability and Advanced Analog Features

Each macrocell, when programmed for a LUT function, uses an 8-bit register to define their output function:

3-Bit LUT13 is defined by registers [855:848]

SLG47004

GreenPAK Programmable Mixed-Signal Matrix with In-System Programmability and Advanced Analog Features

8 Multi-Function Macrocells

The SLG47004 has seven Multi-Function macrocells that can serve as more than one logic or timing function. In each case, they can serve as a LUT, DFF with flexible settings, or as CNT/DLY with multiple modes such as One Shot, Frequency Detect, Edge Detect, and others. Also, the macrocell is capable to combine those functions: LUT/DFF connected to CNT/DLY or CNT/DLY connected to LUT/DFF, see [Figure 31](#).

See the list below for the functions that can be implemented in these macrocells:

- Six macrocells that can serve as 3-bit LUTs/D Flip-Flops and as 8-Bit Counter/Delays
- One macrocell that can serve as a 4-bit LUT/D Flip-Flop and as 16-Bit Counter/Delay/FSM

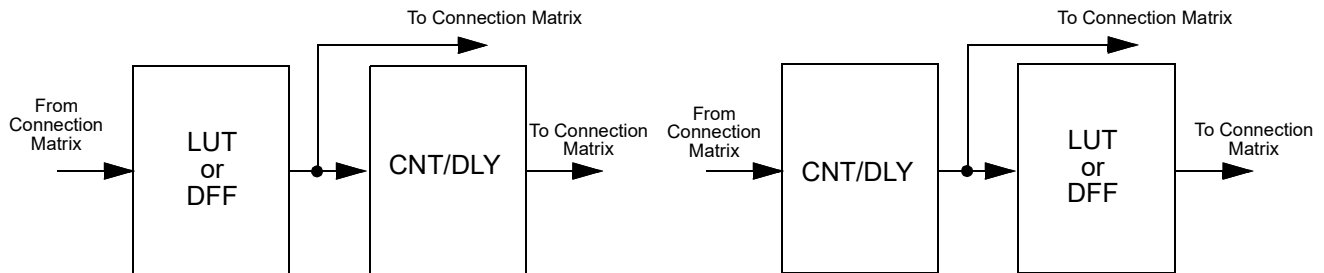

Figure 31: Possible Connections Inside Multi-Function Macrocell

Inputs/Outputs for the seven Multi-Function macrocells are configured from the connection matrix with specific logic functions being defined by the state of NVM bits.

When used as a LUT to implement combinatorial logic functions, the outputs of the LUTs can be configured to any user defined function, including the following standard digital logic devices (AND, NAND, OR, NOR, XOR, XNOR).

8.1 3-BIT LUT OR DFF/LATCH WITH 8-BIT COUNTER/DELAY MACROCELLS

There are six macrocells that can serve as 3-bit LUTs/D Flip-Flops and as 8-Bit Counter/Delays.

When used to implement LUT functions, the 3-bit LUTs each takes in three input signals from the connection matrix and produces a single output, which goes back into the connection matrix or can be connected to CNT/DLY's input.

When used to implement D Flip-Flop function, the three input signals from the connection matrix go to the data (D), clock (CLK), and Reset/Set (nRST/nSET) inputs of the Flip-Flop, with the output going back to the connection matrix or to the CNT/DLY's input.

When used to implement Counter/Delays, each macrocell has a dedicated matrix input connection. For flexibility, each of these macrocells has a large selection of internal and external clock sources, as well as the option to chain from the output of the previous (N-1) CNT/DLY macrocell, to implement longer count/delay circuits. These macrocells can also operate in a One-Shot mode, which will generate an output pulse of user-defined width. They can also operate in a Frequency Detection or Edge Detection mode.

Counter/Delay macrocell has an initial value, which defines its initial value after SLG47004 is powered up. It is possible to select initial Low or initial High, as well as initial value defined by a Delay In signal.

For example, in case initial LOW option is used, the rising edge delay will start operation.

For timing diagrams refer to [Section 8.3](#).

Note: After two DFF – counters initialize with counter data = 0 after POR.
 Initial state = 1 – counters initialize with counter data = 0 after POR.
 Initial state = 0 And After two DFF is bypass – counters initialize with counter data after POR.

SLG47004

GreenPAK Programmable Mixed-Signal Matrix with In-System Programmability and Advanced Analog Features

CNT5 and CNT6 current count value can be read via I²C. However, it is possible to change the counter data (value counter starts operating from) for any macrocell using I²C write commands. In this mode, it is possible to load count data immediately (after two DFF) or after counter ends counting. See Section 18.7.1 for further details.

8.1.1 3-Bit LUT or 8-Bit CNT/DLY Block Diagrams

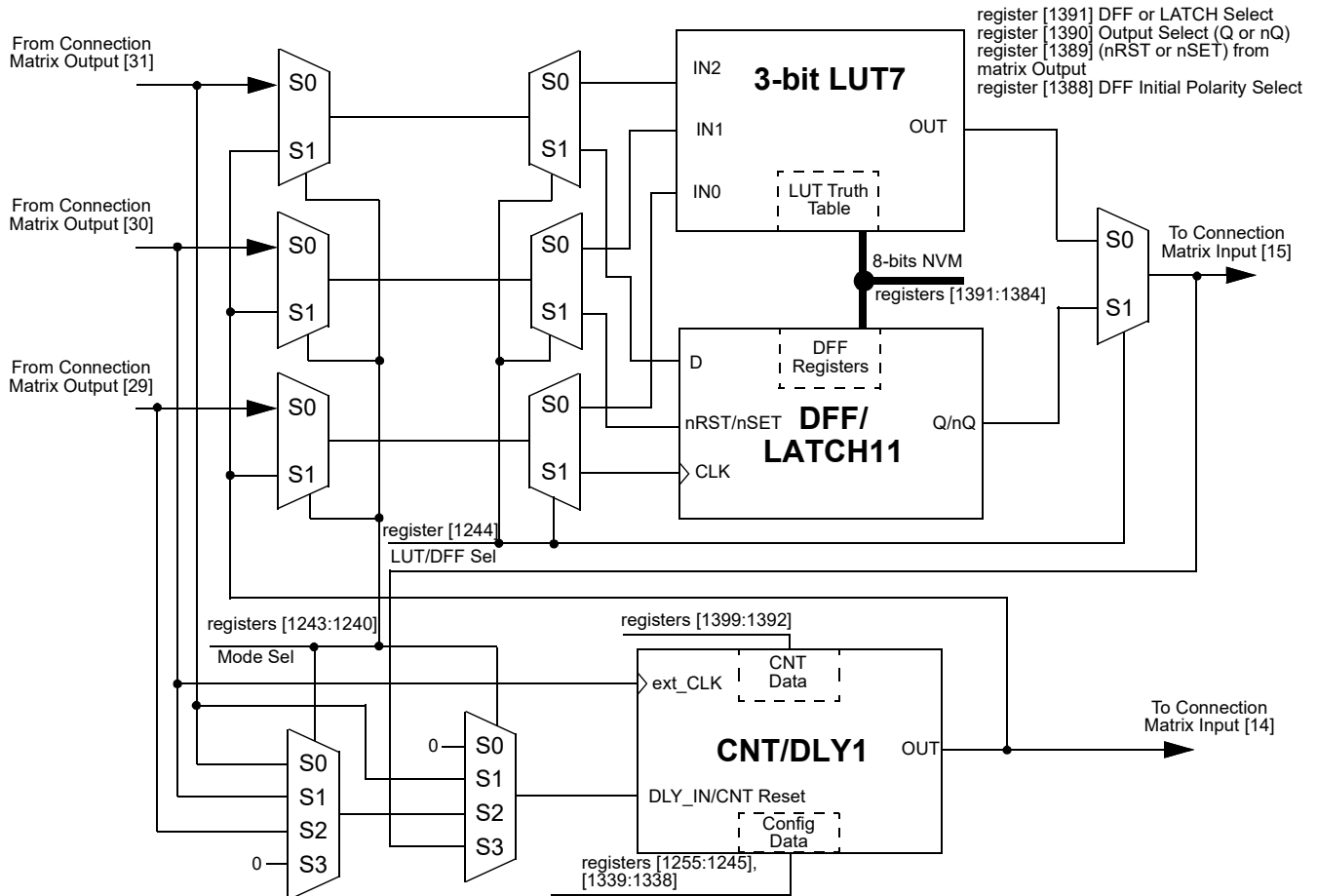

Figure 32: 8-bit Multi-Function Macrocells Block Diagram (3-bit LUT7/DFF11, CNT/DLY1)

SLG47004

GreenPAK Programmable Mixed-Signal Matrix
with In-System Programmability and Advanced Analog Features

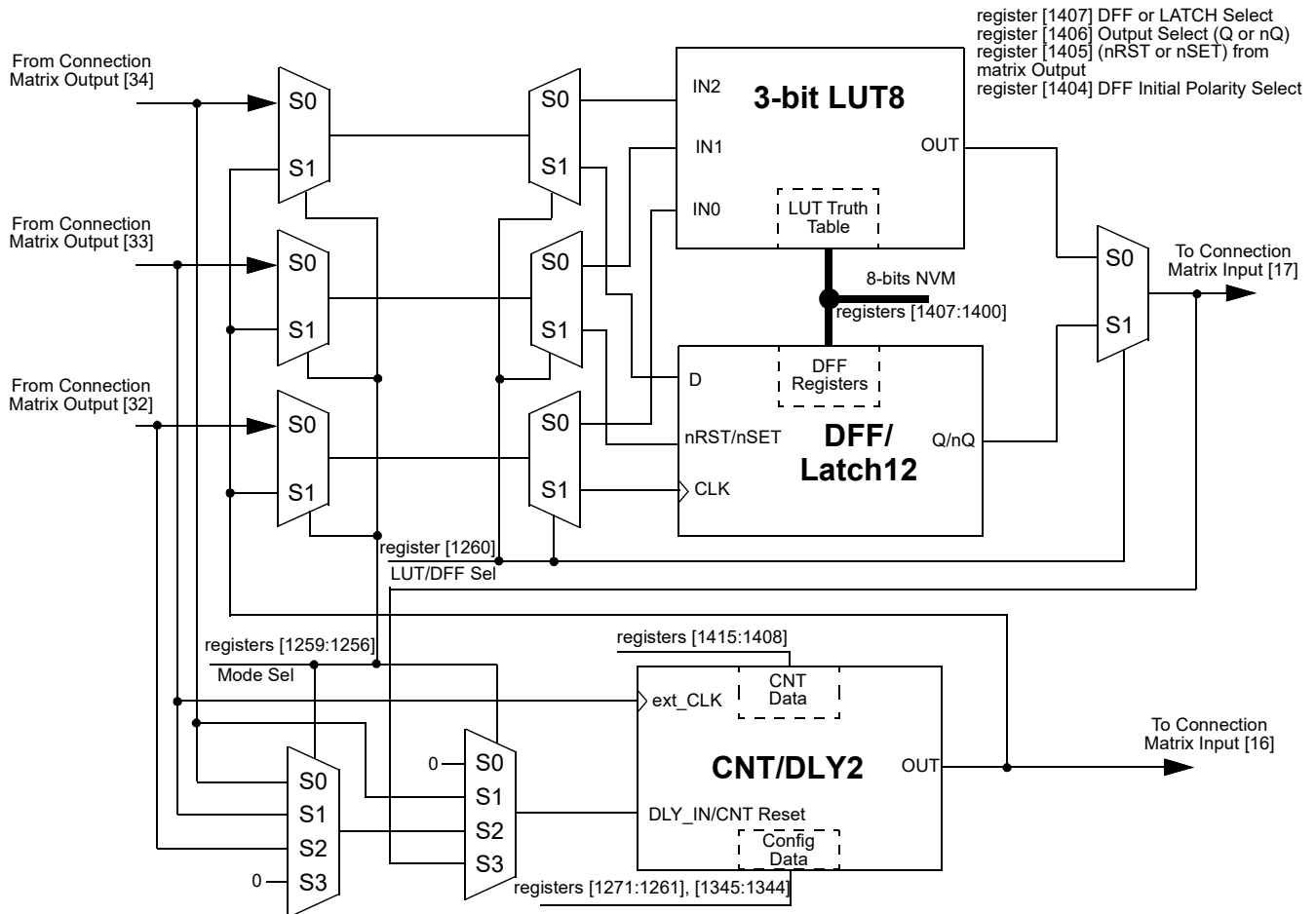

Figure 33: 8-bit Multi-Function Macrocells Block Diagram (3-bit LUT8/DFF12, CNT/DLY2)

SLG47004

GreenPAK Programmable Mixed-Signal Matrix with In-System Programmability and Advanced Analog Features

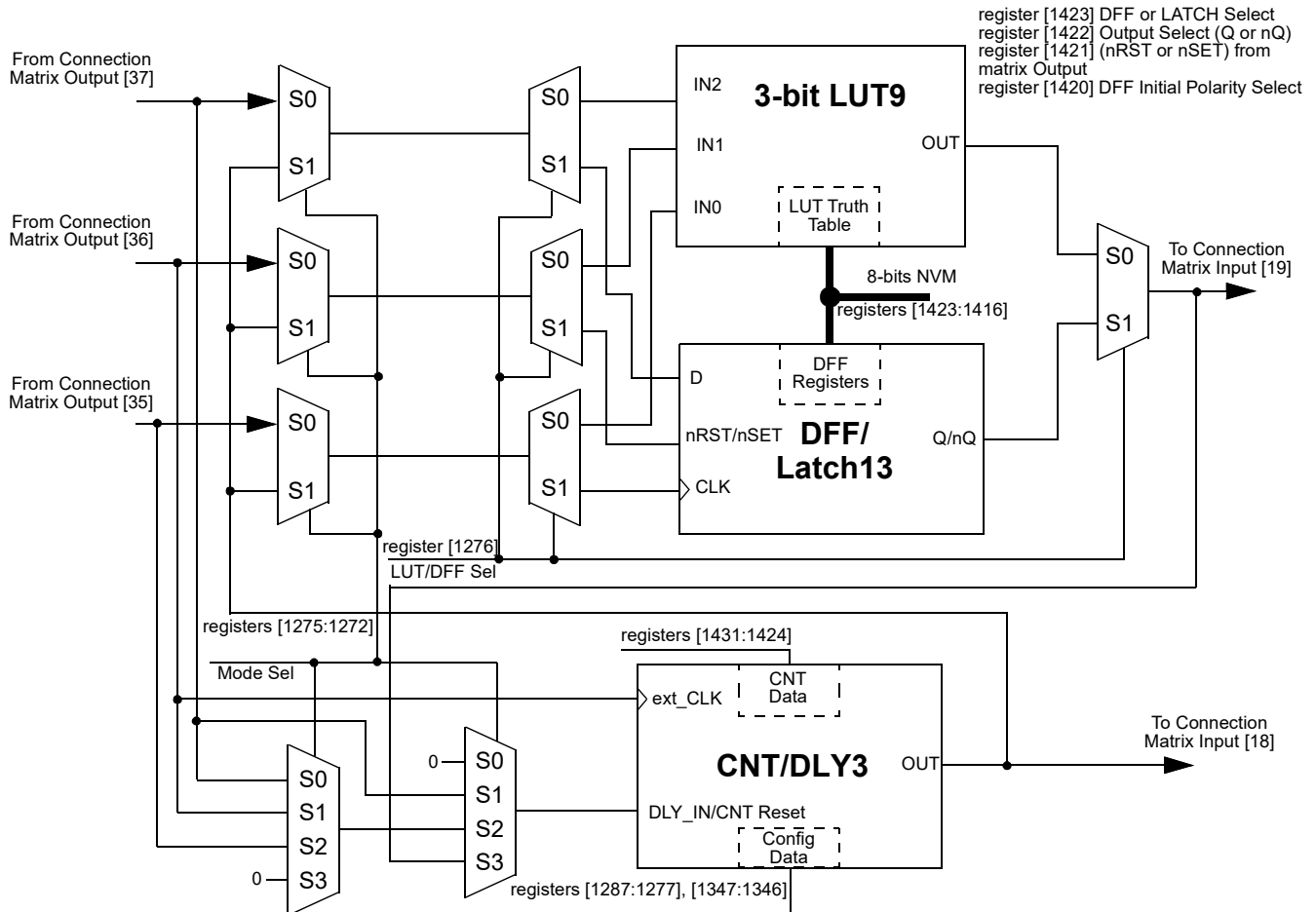

Figure 34: 8-bit Multi-Function Macrocells Block Diagram (3-bit LUT9/DFF13, CNT/DLY3)

SLG47004

GreenPAK Programmable Mixed-Signal Matrix
with In-System Programmability and Advanced Analog Features

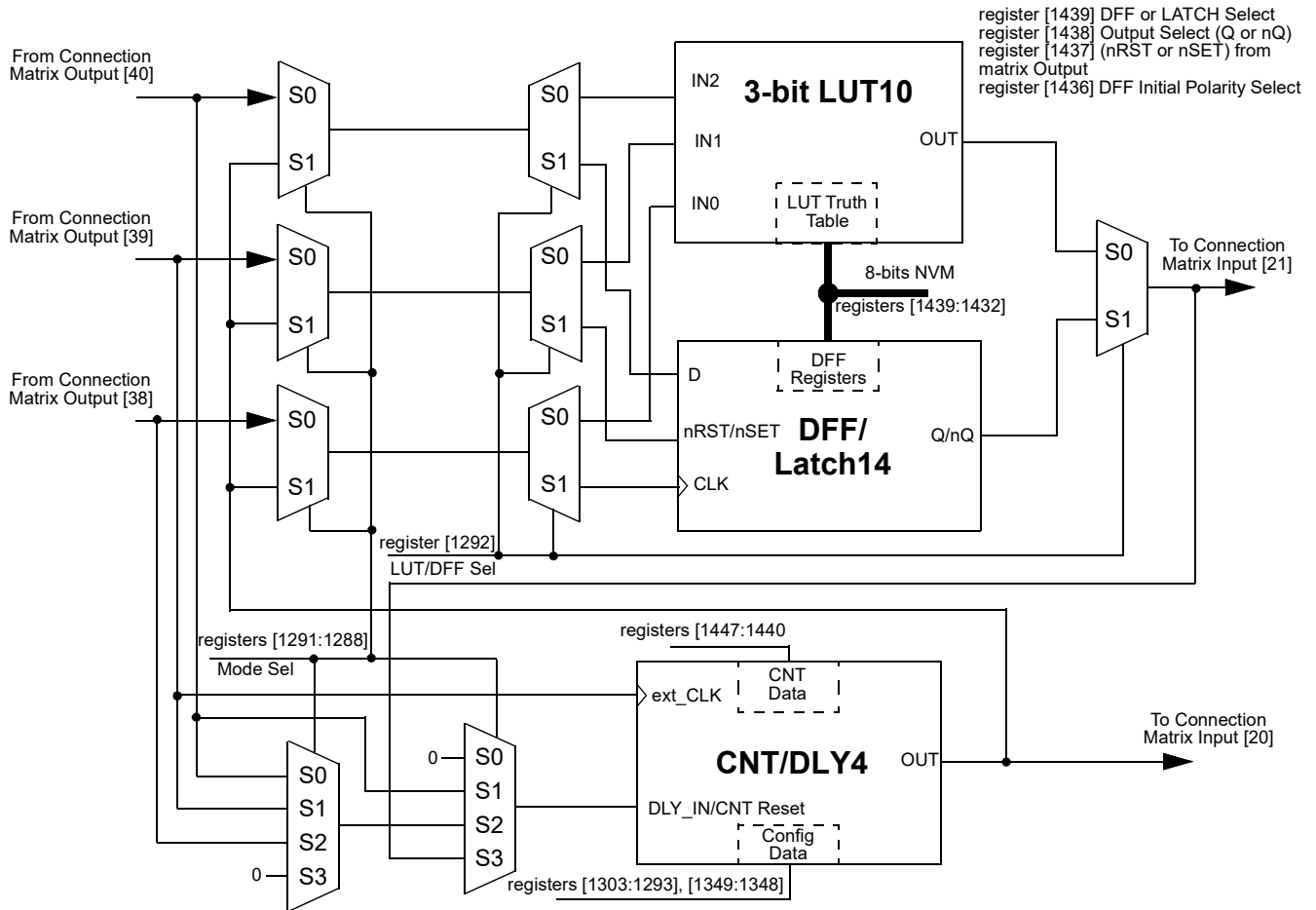

Figure 35: 8-bit Multi-Function Macrocells Block Diagram (3-bit LUT10/DFF14, CNT/DLY4)

SLG47004

GreenPAK Programmable Mixed-Signal Matrix with In-System Programmability and Advanced Analog Features

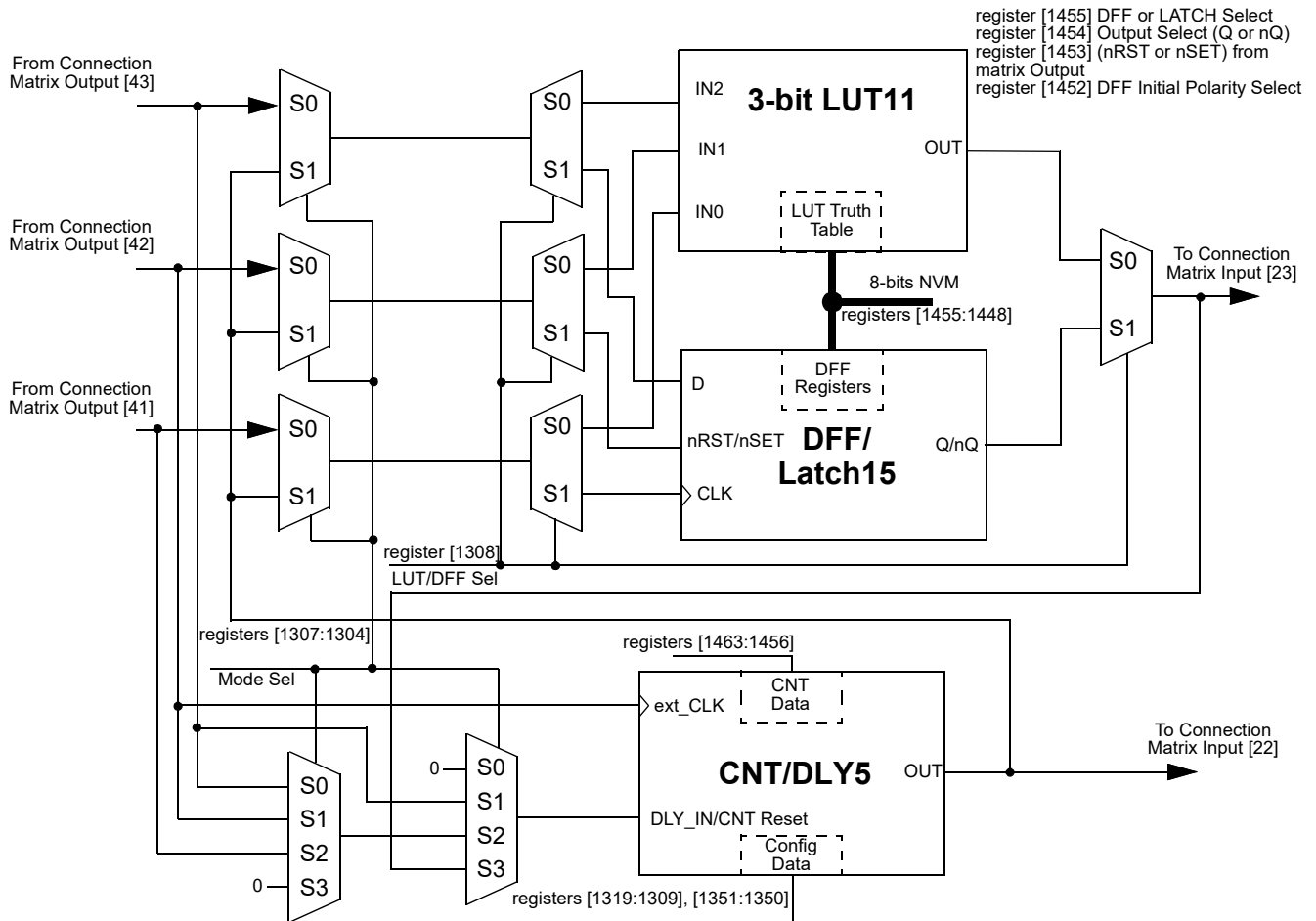

Figure 36: 8-bit Multi-Function Macrocells Block Diagram (3-bit LUT11/DFF15, CNT/DLY5)

SLG47004

GreenPAK Programmable Mixed-Signal Matrix with In-System Programmability and Advanced Analog Features

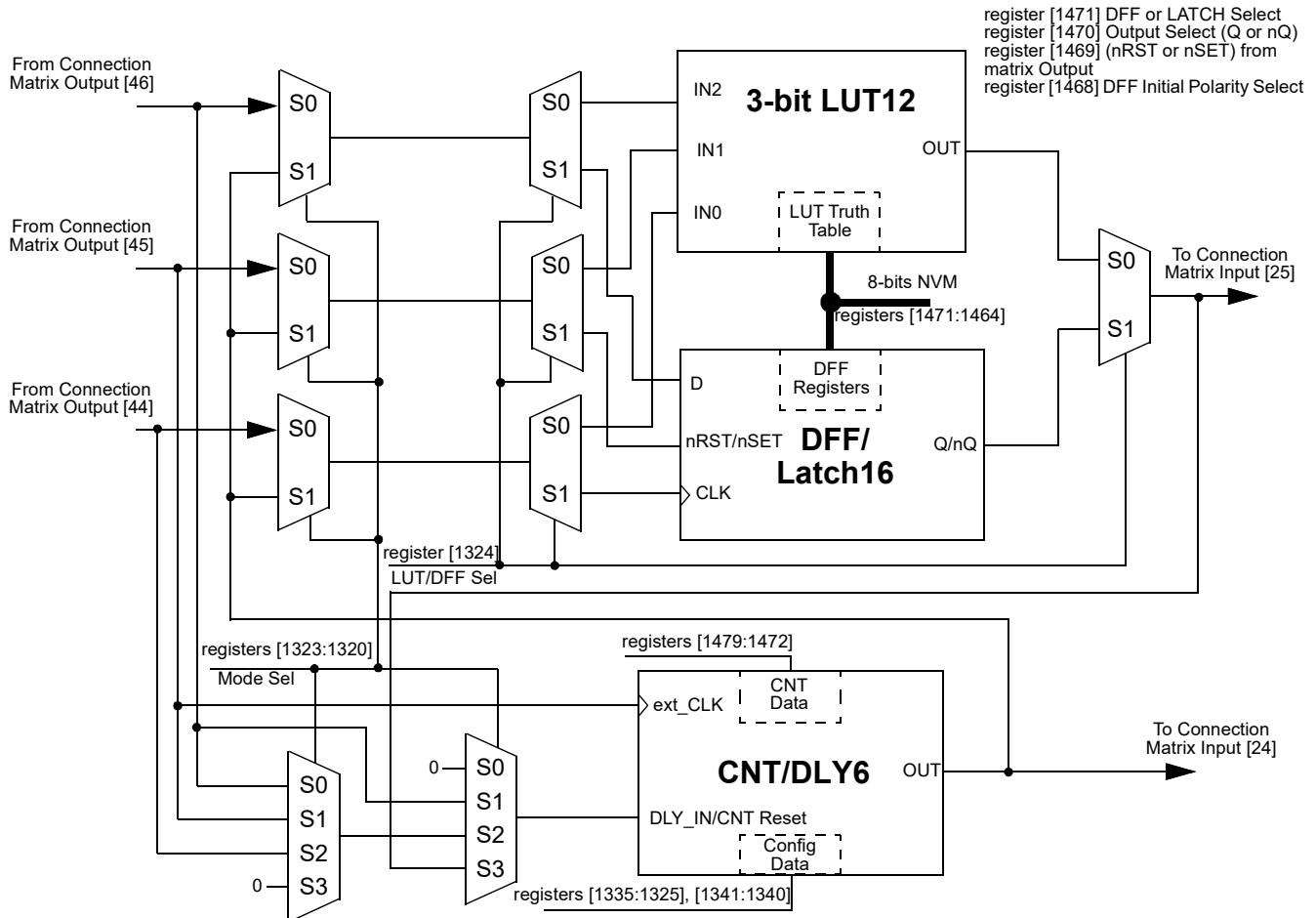

Figure 37: 8-bit Multi-Function Macrocells Block Diagram (3-bit LUT12/DFF16, CNT/DLY6)

As shown in Figure 32 to Figure 37 there is a possibility to use LUT/DFF and CNT/DLY simultaneously.

Note: It is not possible to use LUT and DFF at once, one of these macrocells must be selected.

- Case 1. LUT/DFF in front of CNT/DLY. Three input signals from the connection matrix go to previously selected LUT or DFF's inputs and produce a single output which goes to a CNT/DLY input. In its turn Counter/Delay's output goes back to the matrix.
- Case 2. CNT/DLY in front of LUT/DFF. Two input signals from the connection matrix go to CNT/DLY's inputs (IN and CLK). Its output signal can be connected to any input of previously selected LUT or DFF, after which the signal goes back to the matrix.
- Case 3. Single LUT/DFF or CNT/DLY. Also, it is possible to use a standalone LUT/DFF or CNT/DLY. In this case, all inputs and output of the macrocell are connected to the matrix.

SLG47004

GreenPAK Programmable Mixed-Signal Matrix with In-System Programmability and Advanced Analog Features

8.1.2 3-Bit LUT or CNT/DLYs Used as 3-Bit LUTs

Table 47: 3-bit LUT7 Truth Table

IN2	IN1	IN0	OUT	
0	0	0	register [1384]	LSB
0	0	1	register [1385]	
0	1	0	register [1386]	
0	1	1	register [1387]	
1	0	0	register [1388]	
1	0	1	register [1389]	
1	1	0	register [1390]	
1	1	1	register [1391]	MSB

Table 51: 3-bit LUT11 Truth Table

IN2	IN1	IN0	OUT	
0	0	0	register [1448]	LSB
0	0	1	register [1449]	
0	1	0	register [1450]	
0	1	1	register [1451]	
1	0	0	register [1452]	
1	0	1	register [1453]	
1	1	0	register [1454]	
1	1	1	register [1455]	MSB

Table 48: 3-bit LUT8 Truth Table

IN2	IN1	IN0	OUT	
0	0	0	register [1400]	LSB
0	0	1	register [1401]	
0	1	0	register [1402]	
0	1	1	register [1403]	
1	0	0	register [1404]	
1	0	1	register [1405]	
1	1	0	register [1406]	
1	1	1	register [1407]	MSB

Table 52: 3-bit LUT12 Truth Table

IN2	IN1	IN0	OUT	
0	0	0	register [1464]	LSB
0	0	1	register [1465]	
0	1	0	register [1466]	
0	1	1	register [1467]	
1	0	0	register [1468]	
1	0	1	register [1469]	
1	1	0	register [1470]	
1	1	1	register [1471]	MSB

Table 49: 3-bit LUT9 Truth Table

IN2	IN1	IN0	OUT	
0	0	0	register [1416]	LSB
0	0	1	register [1417]	
0	1	0	register [1418]	
0	1	1	register [1419]	
1	0	0	register [1420]	
1	0	1	register [1421]	
1	1	0	register [1422]	
1	1	1	register [1423]	MSB

Table 50: 3-bit LUT10 Truth Table

IN2	IN1	IN0	OUT	
0	0	0	register [1432]	LSB
0	0	1	register [1433]	
0	1	0	register [1434]	
0	1	1	register [1435]	
1	0	0	register [1436]	
1	0	1	register [1437]	
1	1	0	register [1438]	
1	1	1	register [1439]	MSB

SLG47004

GreenPAK Programmable Mixed-Signal Matrix with In-System Programmability and Advanced Analog Features

Each macrocell, when programmed for a LUT function, uses an 8-bit register to define their output function:

3-Bit LUT7 is defined by registers [1391:1384]

3-Bit LUT8 is defined by registers [1407:1400]

3-Bit LUT9 is defined by registers [1423:1416]

3-Bit LUT10 is defined by registers [1439:1432]

3-Bit LUT11 is defined by registers [1455:1448]

3-Bit LUT12 is defined by registers [1471:1464]

SLG47004

GreenPAK Programmable Mixed-Signal Matrix with In-System Programmability and Advanced Analog Features

8.2 4-BIT LUT OR DFF/LATCH WITH 16-BIT COUNTER/DELAY MACROCELL

There is one macrocell that can serve as either 4-bit LUT/D Flip-Flops or as 16-bit Counter/Delay.

When used to implement LUT function, the 4-bit LUT takes in four input signals from the Connection Matrix and produces a single output, which goes back into the Connection Matrix.

When used to implement D Flip-Flop function, the two input signals from the connection matrix go to the data (D) and clock (CLK) inputs for the Flip-Flop, with the output going back to the connection matrix.

When used to implement 16-Bit Counter/Delay function, two of the four input signals from the connection matrix go to the external clock (EXT_CLK) and reset (DLY_IN/CNT Reset) for the Counter/Delay, with the output going back to the connection matrix.

This macrocell has an optional Finite State Machine (FSM) function. There are two additional matrix inputs for Up and Keep to support FSM functionality

This macrocell can also operate in a one-shot mode, which will generate an output pulse of user-defined width. This macrocell can also operate in a frequency detection or edge detection mode. This macrocell can have its active count value read via I²C. See Section 18.7.1 for further details.

Note: After two DFF – counters initialize with counter data = 0 after POR.

Initial state = 1 – counters initialize with counter data = 0 after POR.

Initial state = 0 And After two DFF is bypass – counters initialize with counter data after POR.

SLG47004

GreenPAK Programmable Mixed-Signal Matrix with In-System Programmability and Advanced Analog Features

8.2.1 4-Bit LUT or DFF/LATCH with 16-Bit CNT/DLY Block Diagram

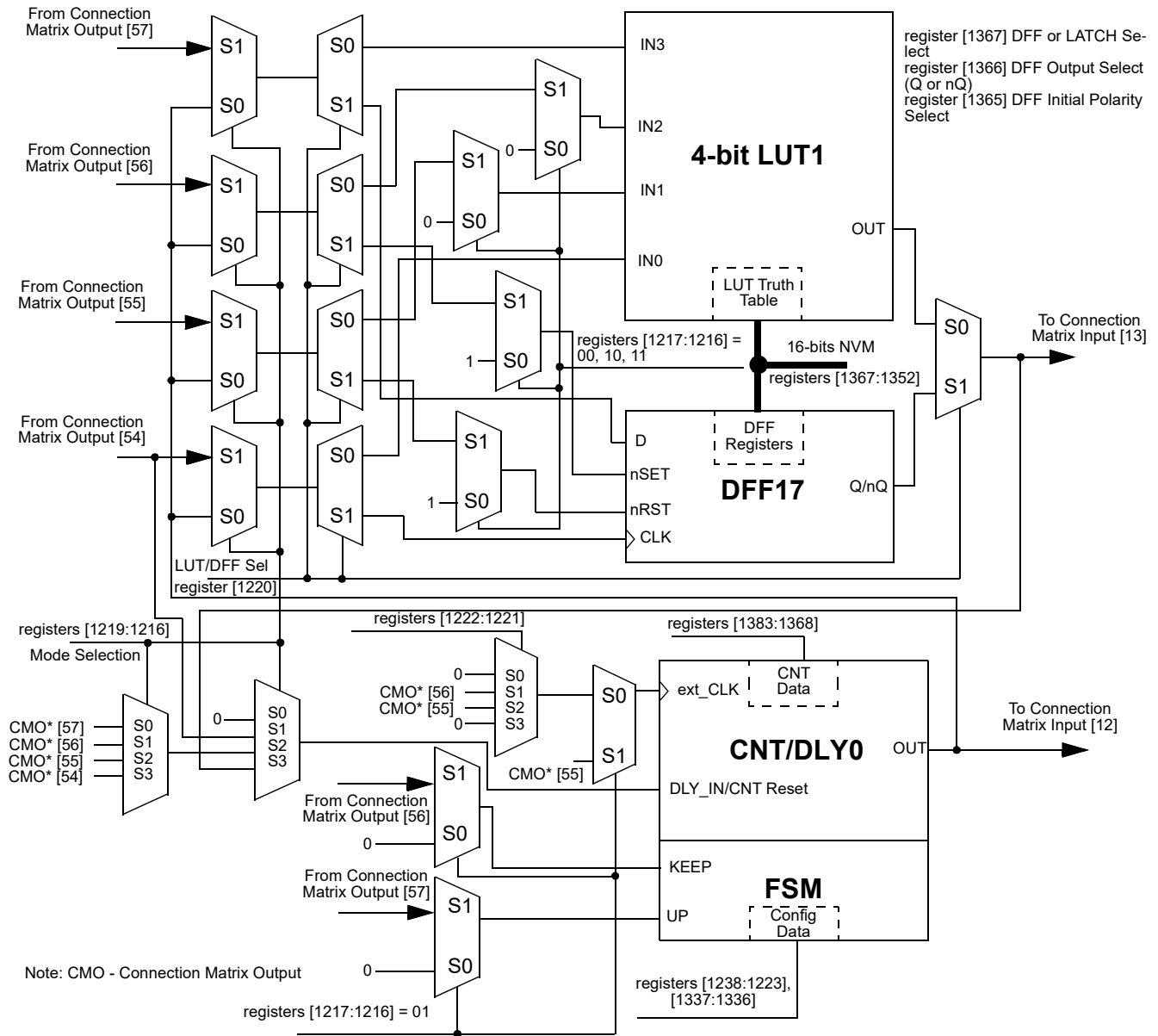

Figure 38: 4-bit LUT1 or CNT/DLY0

SLG47004

GreenPAK Programmable Mixed-Signal Matrix with In-System Programmability and Advanced Analog Features

8.2.2 4-Bit LUT or 16-Bit Counter/Delay Macrocells Used as 4-Bit LUTs

Table 53: 4-bit LUT1 Truth Table

IN3	IN2	IN1	IN0	OUT	
0	0	0	0	register [1352]	LSB
0	0	0	1	register [1353]	
0	0	1	0	register [1354]	
0	0	1	1	register [1355]	
0	1	0	0	register [1356]	
0	1	0	1	register [1357]	
0	1	1	0	register [1358]	
0	1	1	1	register [1359]	
1	0	0	0	register [1360]	
1	0	0	1	register [1361]	
1	0	1	0	register [1362]	
1	0	1	1	register [1363]	
1	1	0	0	register [1364]	
1	1	0	1	register [1365]	
1	1	1	0	register [1366]	
1	1	1	1	register [1367]	MSB

This macrocell, when programmed for a LUT function, uses a 16-bit register to define their output function:

4-Bit LUT1 is defined by registers [1367:1352]

Table 54: 4-bit LUT Standard Digital Functions

Function	MSB															LSB
AND-4	1	0	0	0	0	0	0	0	0	0	0	0	0	0	0	0
NAND-4	0	1	1	1	1	1	1	1	1	1	1	1	1	1	1	1
OR-4	1	1	1	1	1	1	1	1	1	1	1	1	1	1	1	0
NOR-4	0	0	0	0	0	0	0	0	0	0	0	0	0	0	0	1
XOR-4	0	1	1	0	1	0	0	1	1	1	0	0	1	1	1	0
XNOR-4	1	0	0	1	0	1	1	0	0	0	1	1	0	0	0	1

SLG47004

GreenPAK Programmable Mixed-Signal Matrix with In-System Programmability and Advanced Analog Features

8.3 CNT/DLY/FSM TIMING DIAGRAMS

8.3.1 Delay Mode CNT/DLY0 to CNT/DLY6

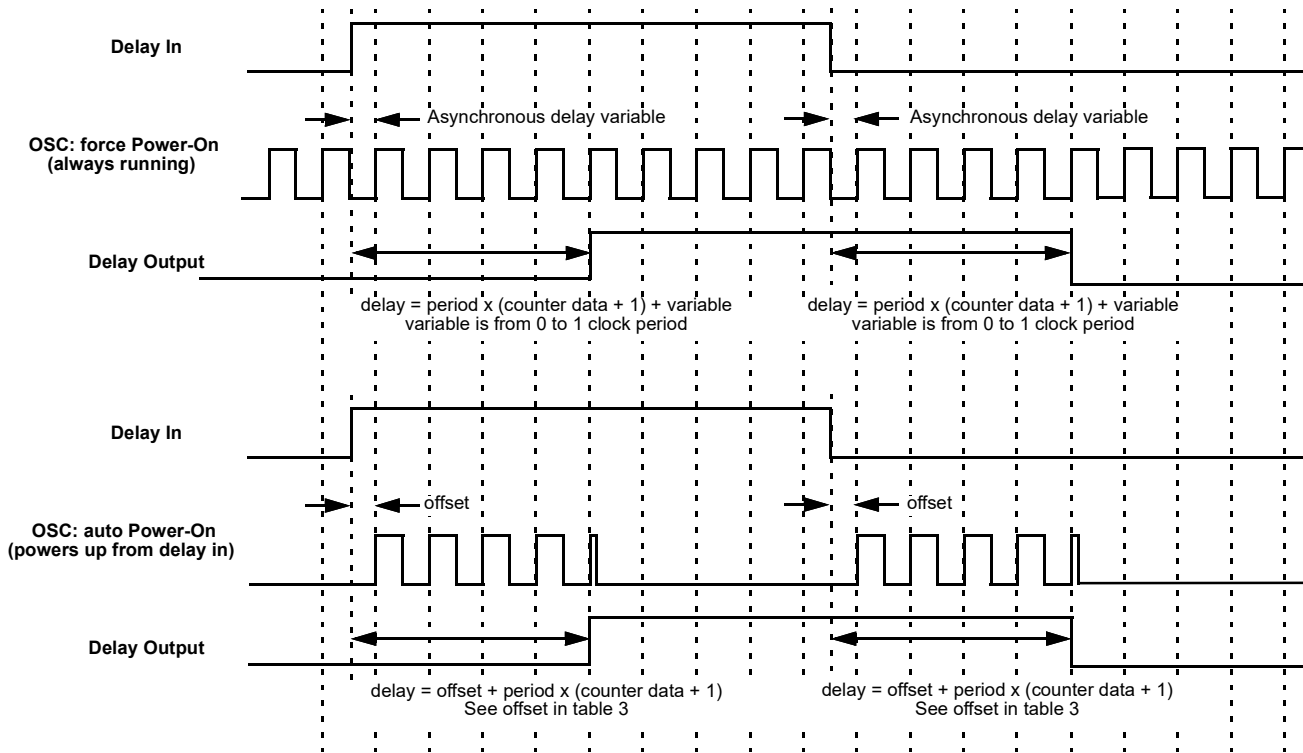

Figure 39: Delay Mode Timing Diagram, Edge Select: Both, Counter Data: 3

SLG47004

GreenPAK Programmable Mixed-Signal Matrix with In-System Programmability and Advanced Analog Features

The macrocell shifts the respective edge to a set time and restarts by appropriate edge. It works as a filter if the input signal is shorter than the delay time.

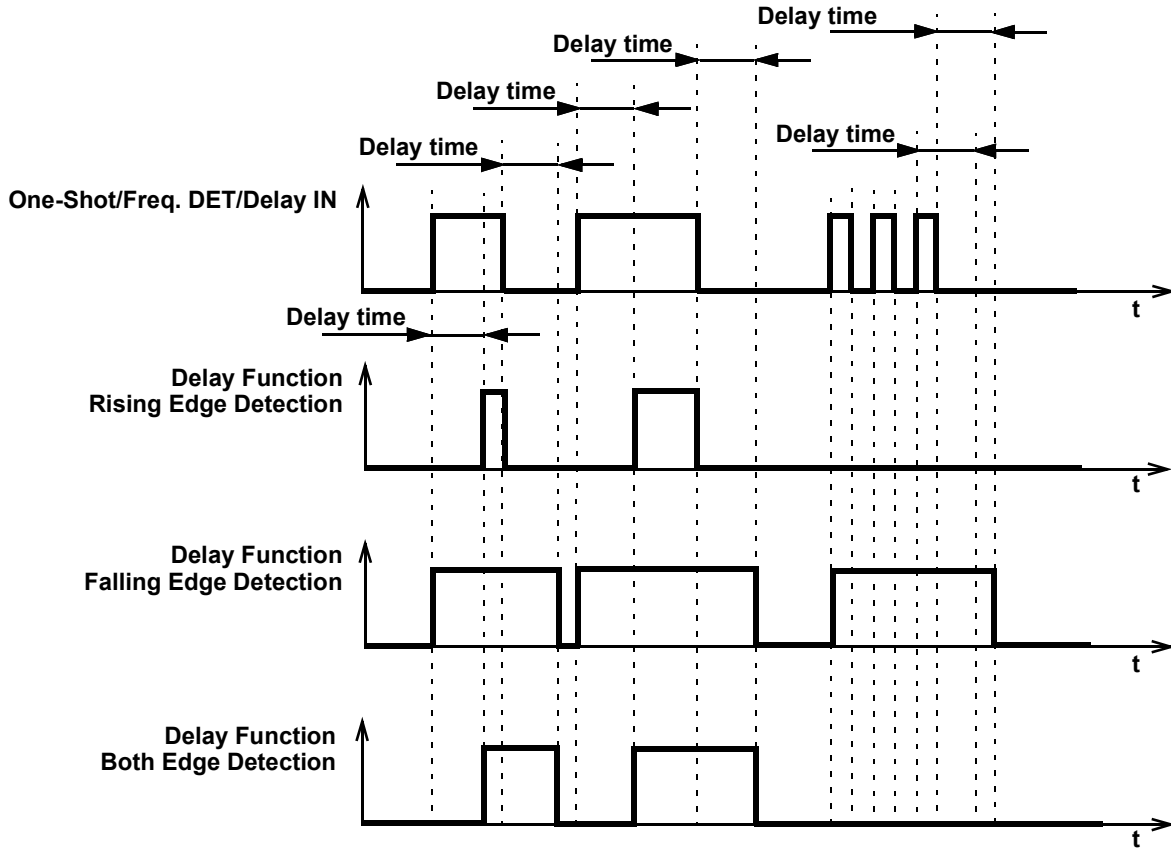

Figure 40: Delay Mode Timing Diagram for Different Edge Select Modes

8.3.2 Count Mode (Count Data: 3), Counter Reset (Rising Edge Detect) CNT/DLY0 to CNT/DLY6

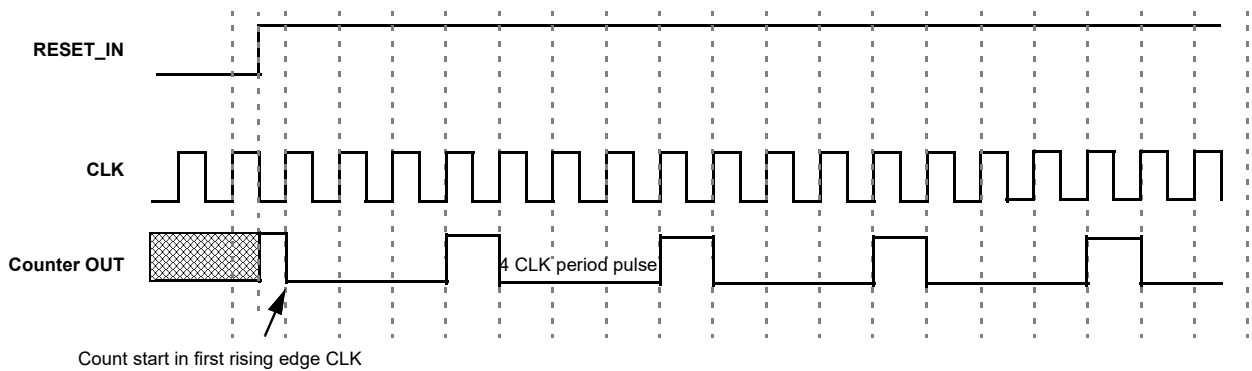

Figure 41: Counter Mode Timing Diagram without Two DFFs Synced Up

SLG47004

GreenPAK Programmable Mixed-Signal Matrix
with In-System Programmability and Advanced Analog Features

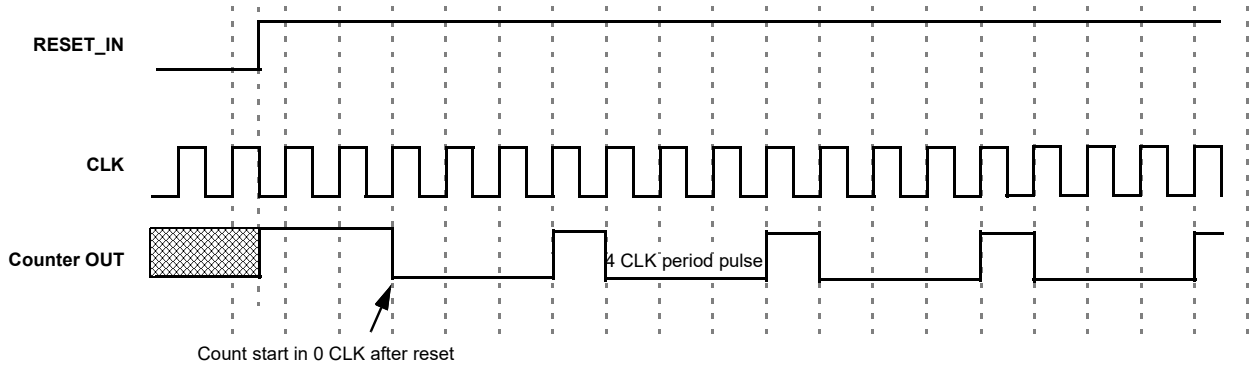

Figure 42: Counter Mode Timing Diagram with Two DFFs Synced Up

SLG47004

GreenPAK Programmable Mixed-Signal Matrix with In-System Programmability and Advanced Analog Features

8.3.3 One-Shot Mode CNT/DLY0 to CNT/DLY6

This macrocell will generate a pulse whenever a selected edge is detected on its input. Register bits set the edge selection. The pulse width is determined by counter data and clock selection properties.

The output pulse polarity (non-inverted or inverted) is selected by register bit. Any incoming edges will be ignored during the pulse width generation. The following diagram shows one-shot function for non-inverted output.

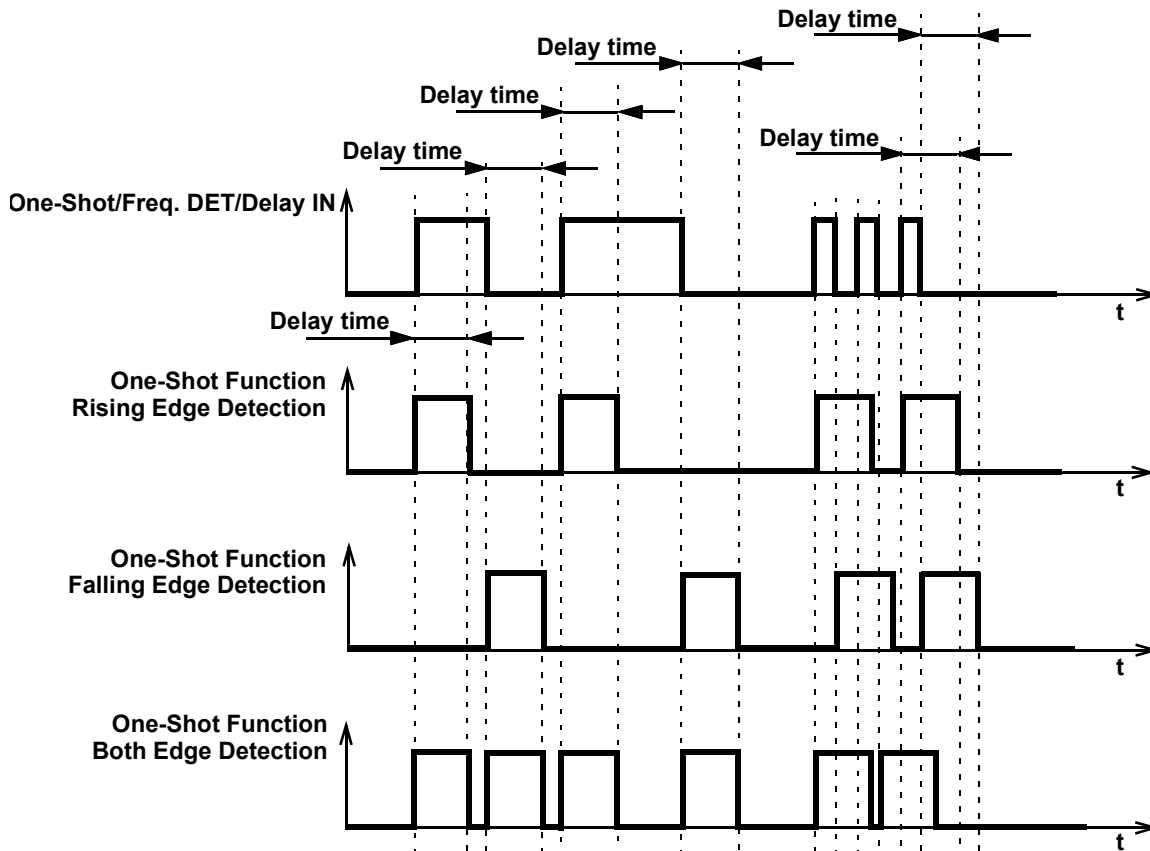

Figure 43: One-Shot Function Timing Diagram

This macrocell generates a high level pulse with a set width (defined by counter data) when detecting the respective edge. It does not restart while pulse is high.

8.3.4 Frequency Detection Mode CNT/DLY0 to CNT/DLY6

Rising Edge: The output goes high if the time between two successive edges is less than the delay. The output goes low if the second rising edge has not come after the last rising edge in specified time.

Falling Edge: The output goes high if the time between two falling edges is less than the set time. The output goes low if the second falling edge has not come after the last falling edge in specified time.

Both Edge: The output goes high if the time between the rising and falling edges is less than the set time, which is equivalent to the length of the pulse. The output goes low if after the last rising/falling edge and specified time, the second edge has not come.

SLG47004

GreenPAK Programmable Mixed-Signal Matrix
with In-System Programmability and Advanced Analog Features

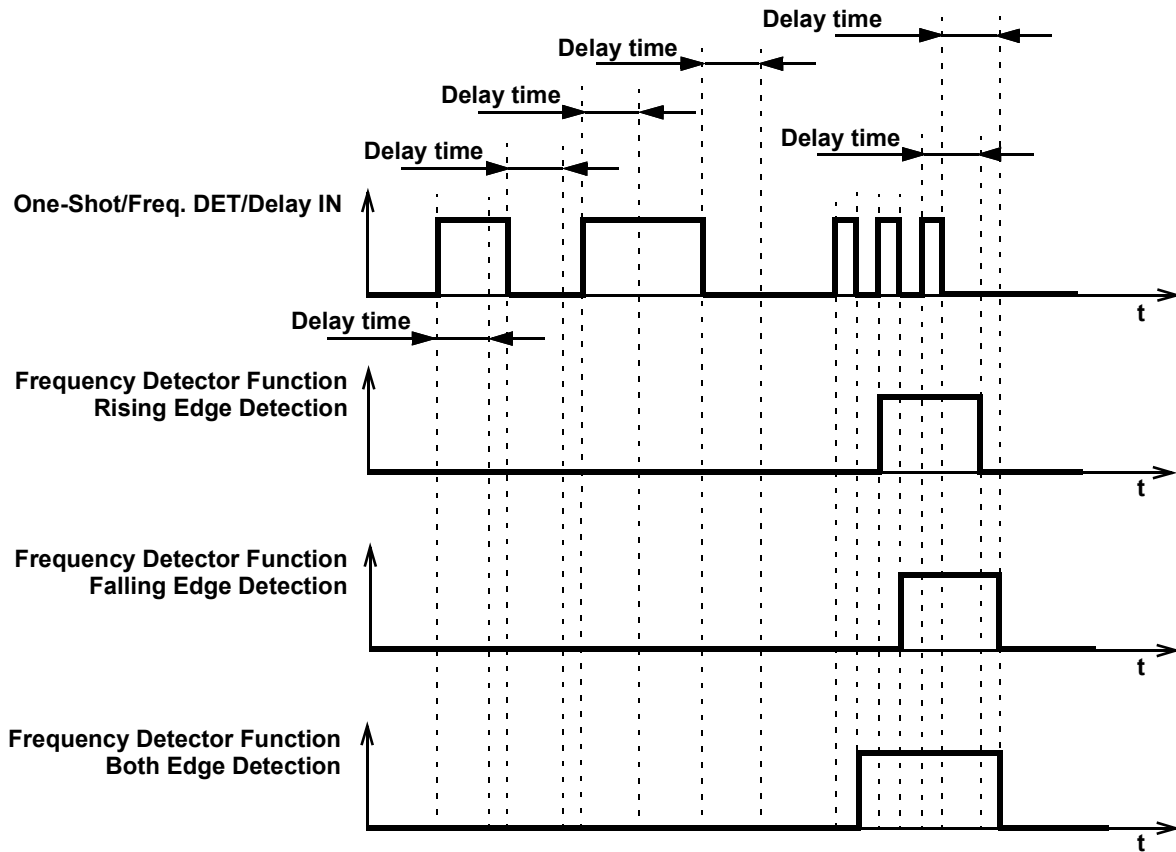

Figure 44: Frequency Detection Mode Timing Diagram

SLG47004

GreenPAK Programmable Mixed-Signal Matrix with In-System Programmability and Advanced Analog Features

8.3.5 Edge Detection Mode CNT/DLY1 to CNT/DLY6

The macrocell generates high level short pulse when detecting the respective edge. See Table 11.

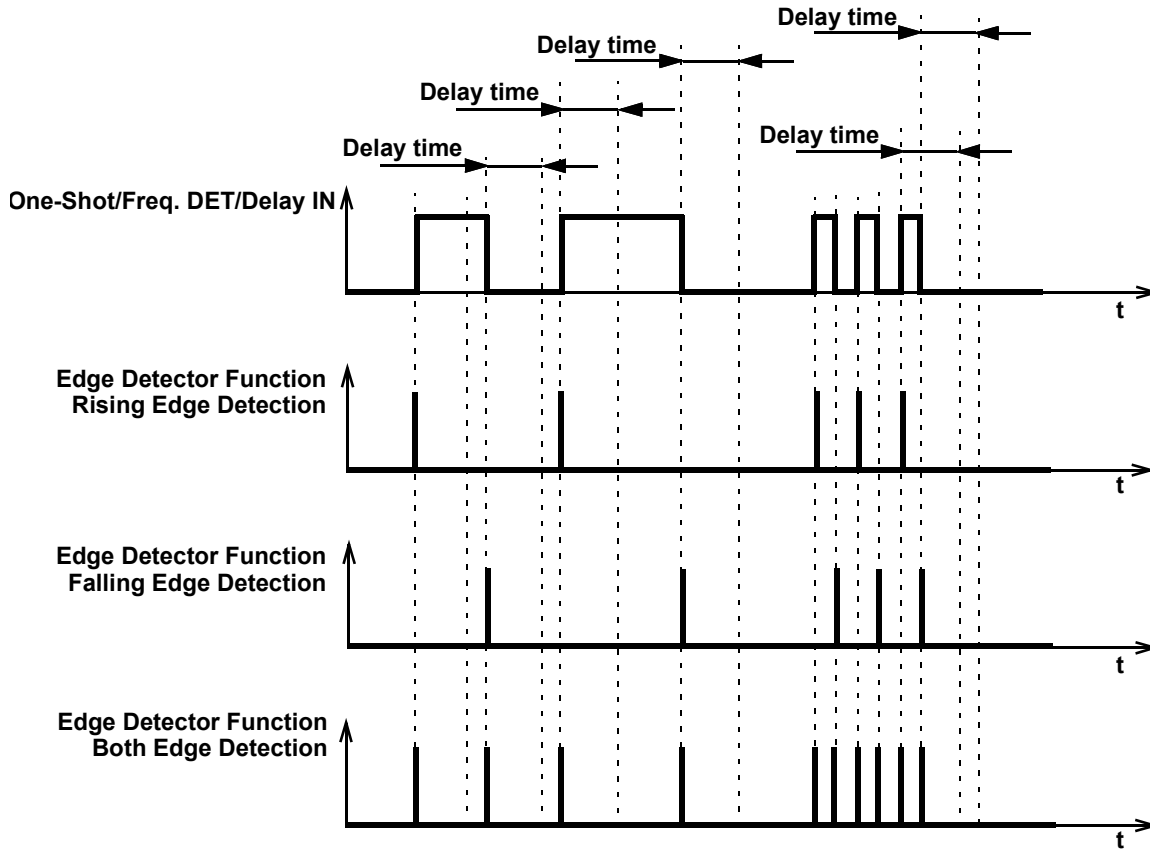

Figure 45: Edge Detection Mode Timing Diagram

8.3.6 Delayed Edge Detection Mode CNT/DLY0 to CNT/DLY6

In Delayed Edge Detection Mode, High-level short pulses are generated on the macrocell output after the configured delay time, if the corresponding edge was detected on the input.

If the input signal is changed during the set delay time, the pulse will not be generated.

SLG47004

GreenPAK Programmable Mixed-Signal Matrix with In-System Programmability and Advanced Analog Features

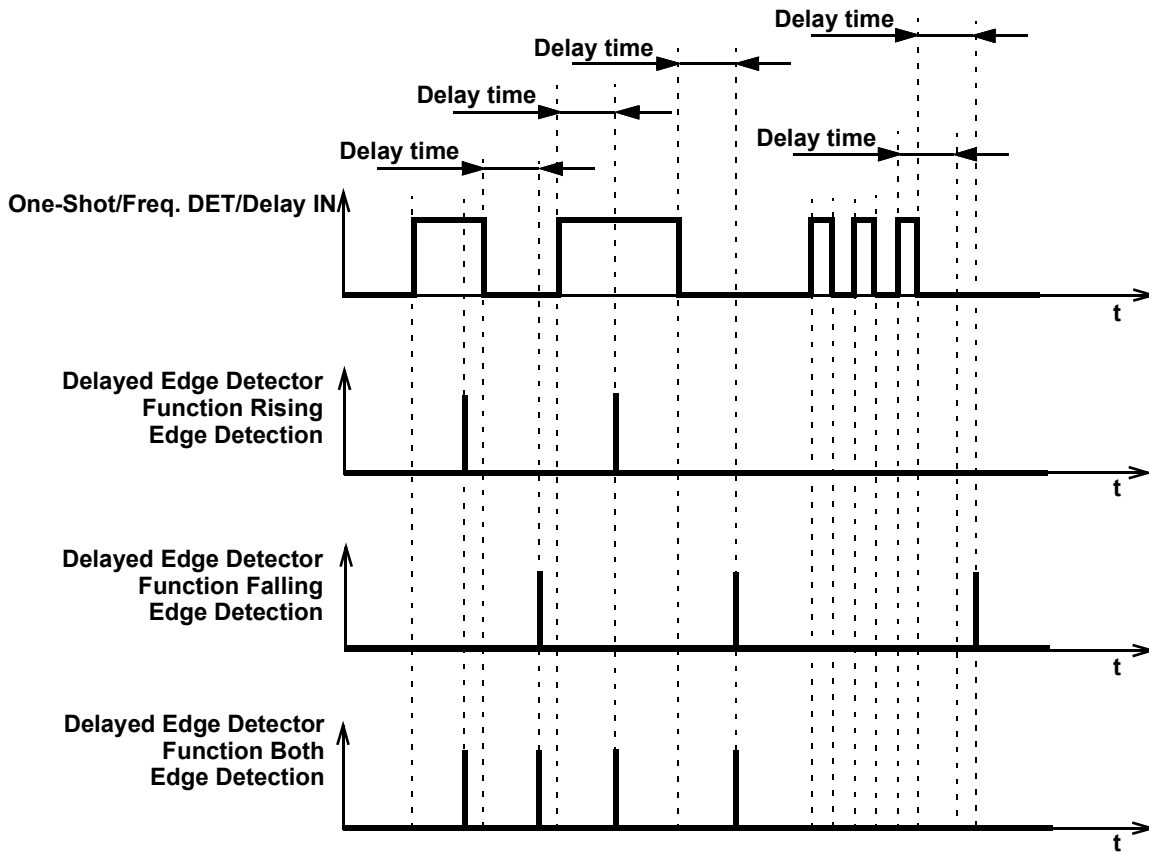

Figure 46: Delayed Edge Detection Mode Timing Diagram

8.3.7 CNT/FSM Mode CNT/DLY0

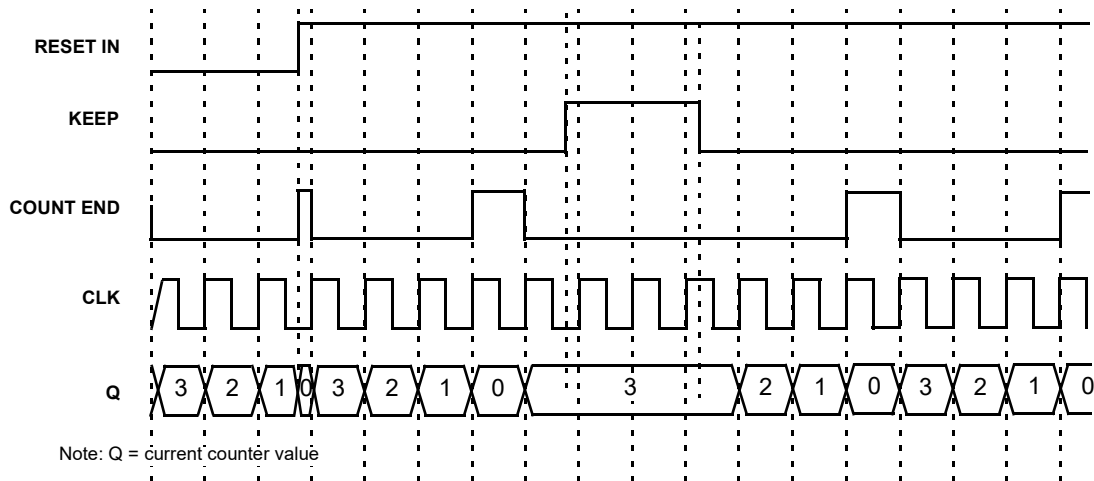

Figure 47: CNT/FSM Timing Diagram (Reset Rising Edge Mode, Oscillator is Forced On, UP = 0) for Counter Data = 3

SLG47004

GreenPAK Programmable Mixed-Signal Matrix
with In-System Programmability and Advanced Analog Features

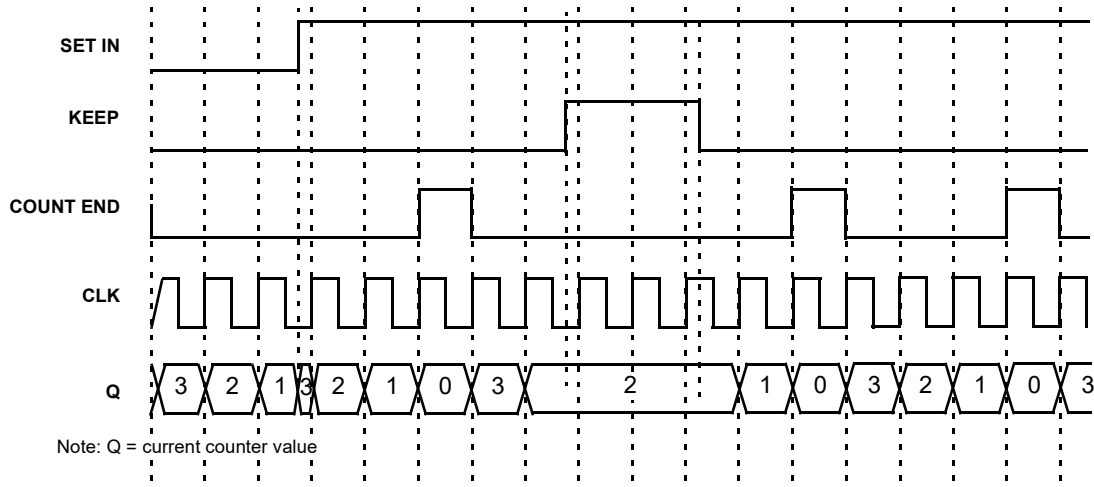

Figure 48: CNT/FSM Timing Diagram (Set Rising Edge Mode, Oscillator is Forced On, UP = 0) for Counter Data = 3

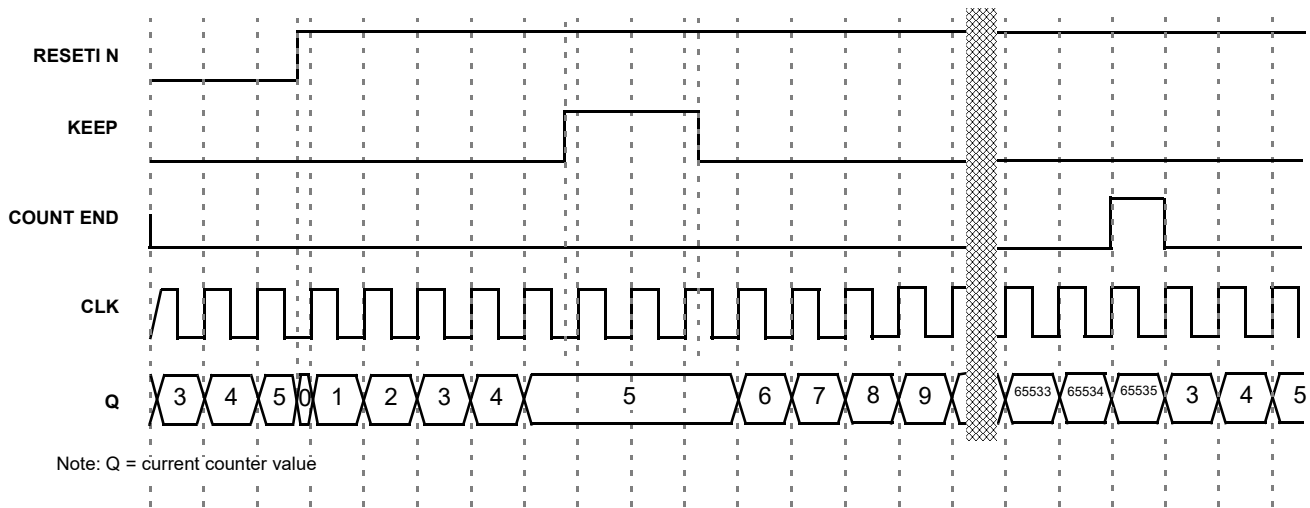
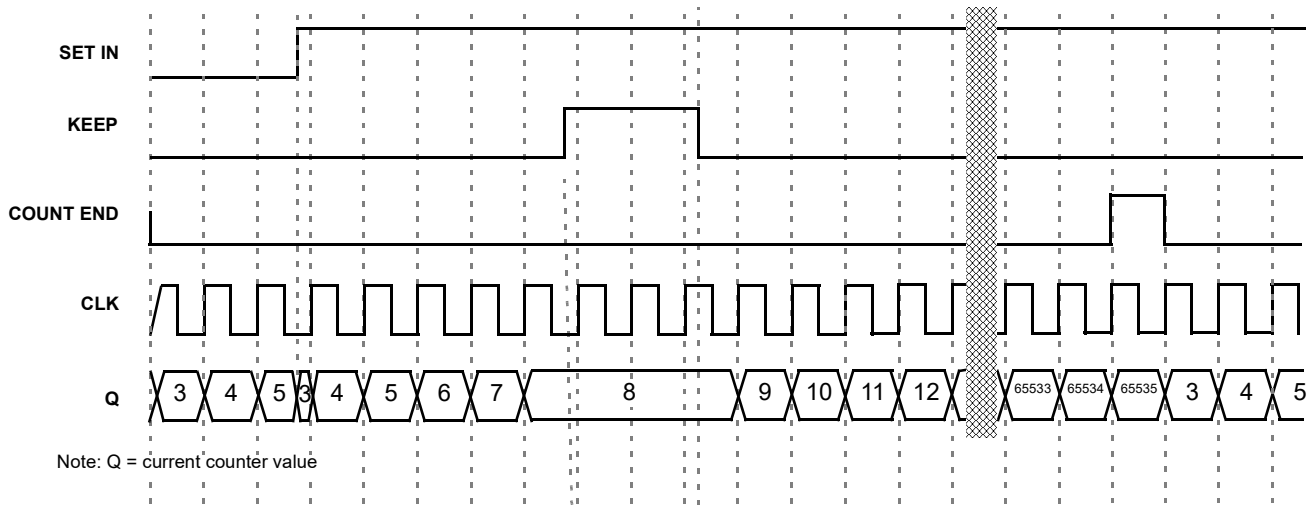

Figure 49: CNT/FSM Timing Diagram (Reset Rising Edge Mode, Oscillator is Forced On, UP = 1) for Counter Data = 3



8.3.8 Difference in Counter Value for Counter, Delay, One-Shot, and Frequency Detect Modes

There is a difference in counter value for Counter and Delay/One-Shot/Frequency Detect modes. Compared to Counter mode, in Delay/One-Shot/Frequency Detect modes the counter value is shifted for two rising edges of the clock signal. See Figure 51.

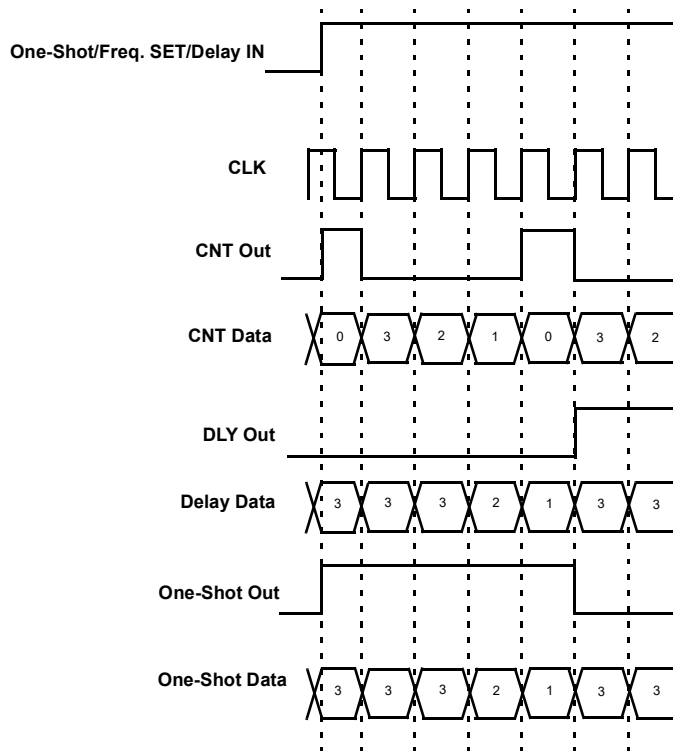

Figure 51: Counter Value, Counter Data = 3

SLG47004

GreenPAK Programmable Mixed-Signal Matrix with In-System Programmability and Advanced Analog Features

8.4 WAKE AND SLEEP CONTROLLER

The SLG47004 has a Wake and Sleep (WS) function for ACMP. The macrocell CNT/DLY0 can be reconfigured for this purpose registers [1224:1223] = 11 and register [1232] = 1. The WS serves for power saving, it allows to switch on and off selected ACMPs on selected bit of 16-bit counter.

Note 1: BG/Analog_Good time is long and should be considered in the wake and sleep timing in case it dynamically powers on/off.

Note 2: Wake time should be long enough to make sure ACMP and Vref have enough time to get a sample before going to sleep.

Note 3: ACMPs power up must be connected to POR.

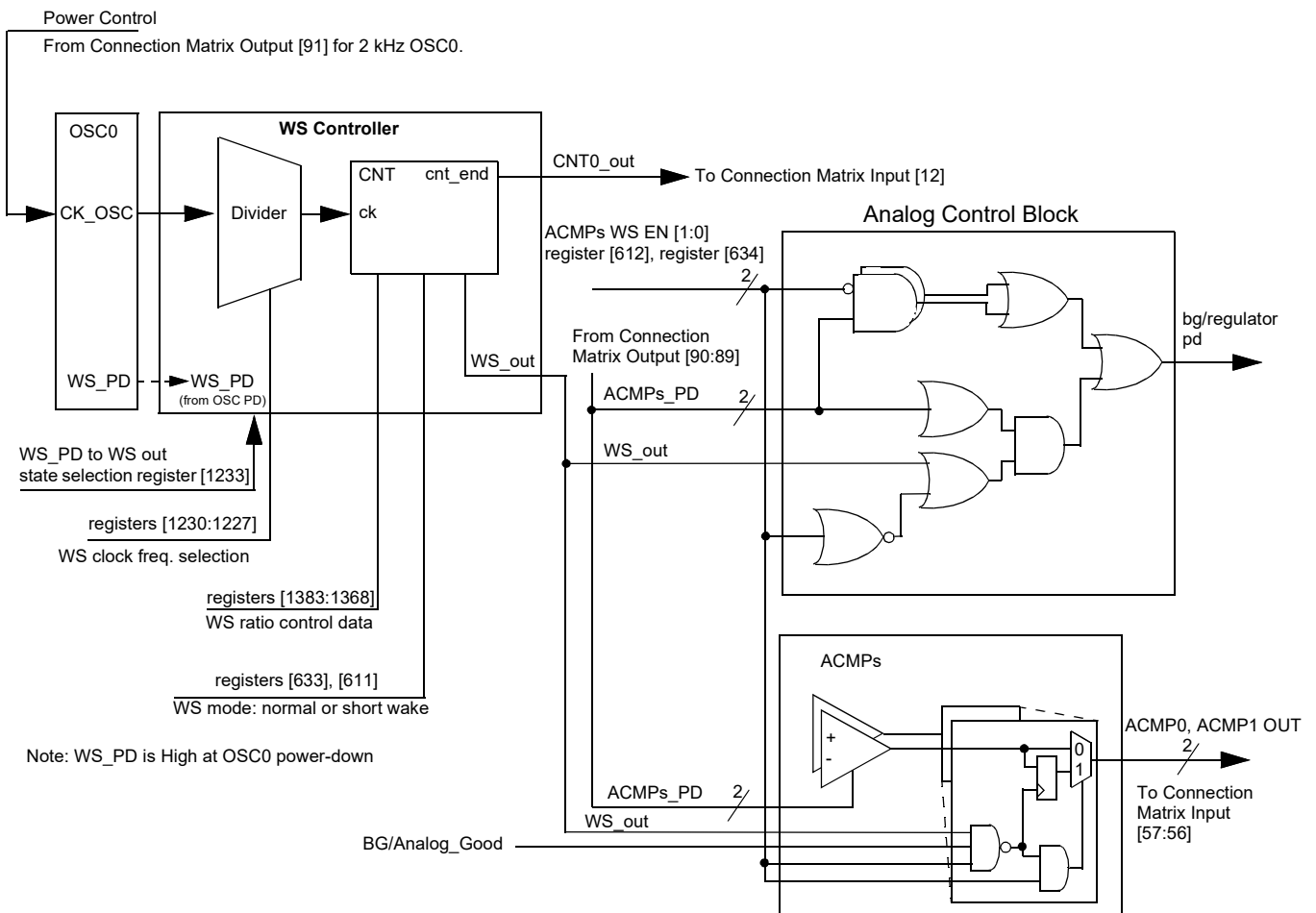

Figure 52: Wake and Sleep Controller

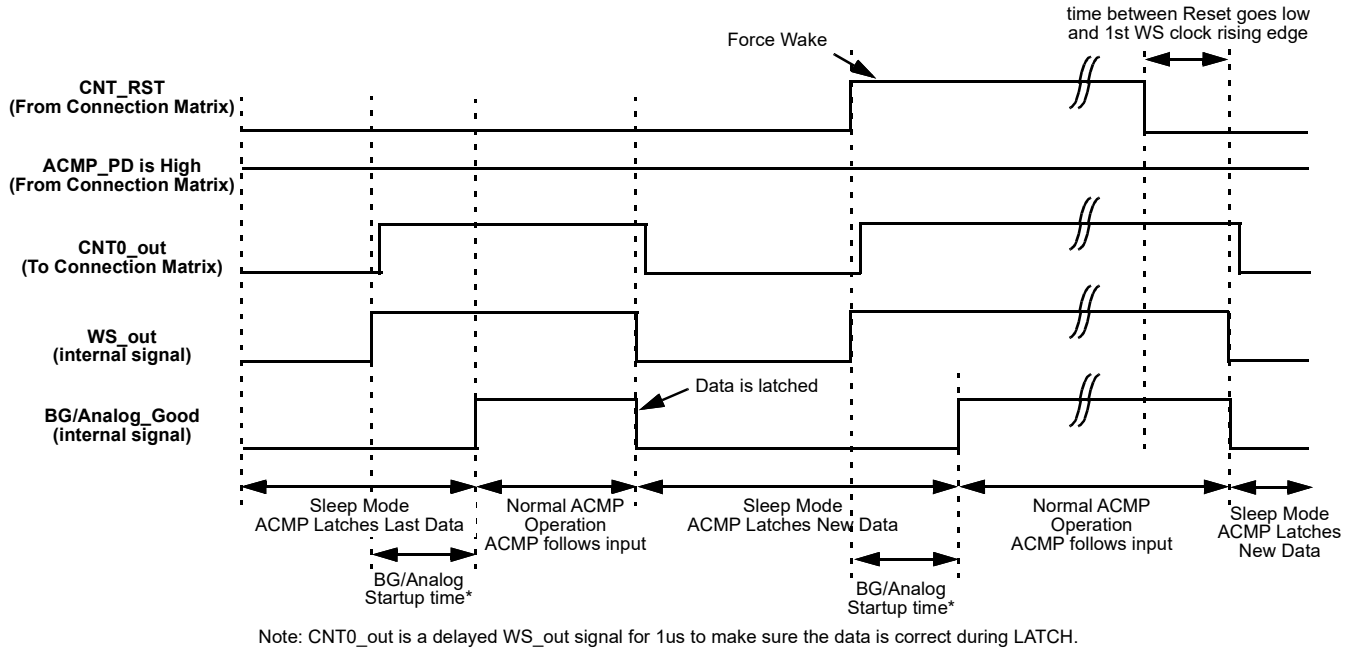

Figure 53: Wake and Sleep Timing Diagram, Normal Wake Mode, Counter Reset is Used

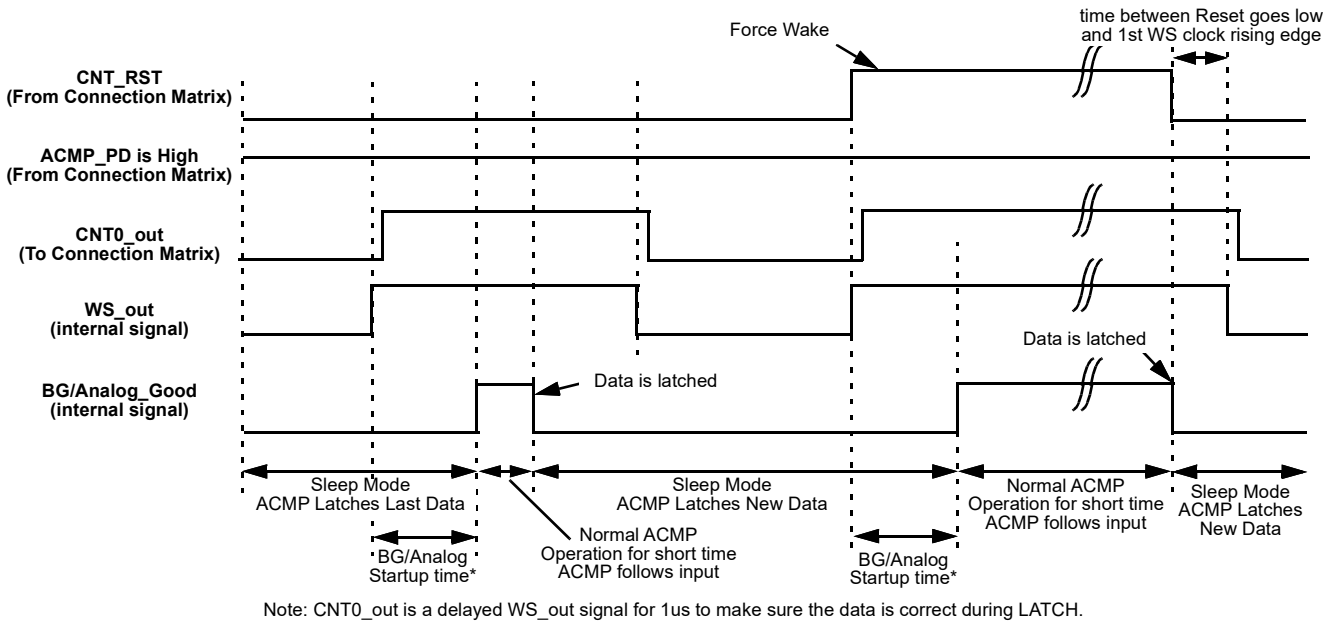

Figure 54: Wake and Sleep Timing Diagram, Short Wake Mode, Counter Reset is Used

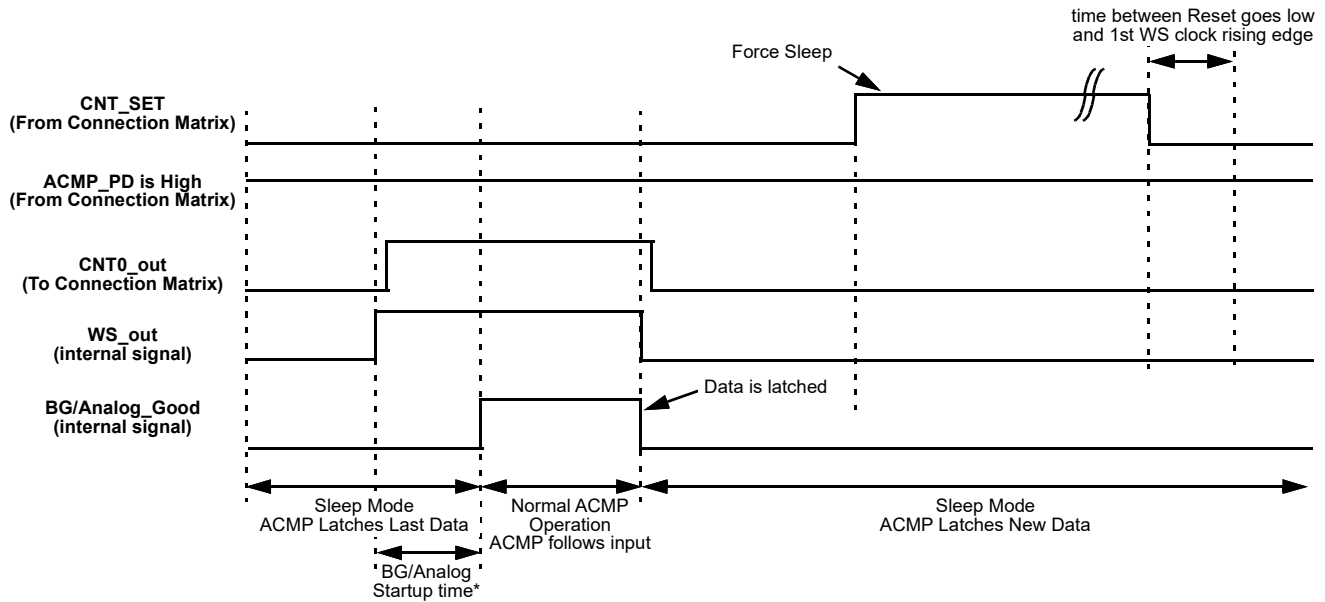

Figure 55: Wake and Sleep Timing Diagram, Normal Wake Mode, Counter Set is Used

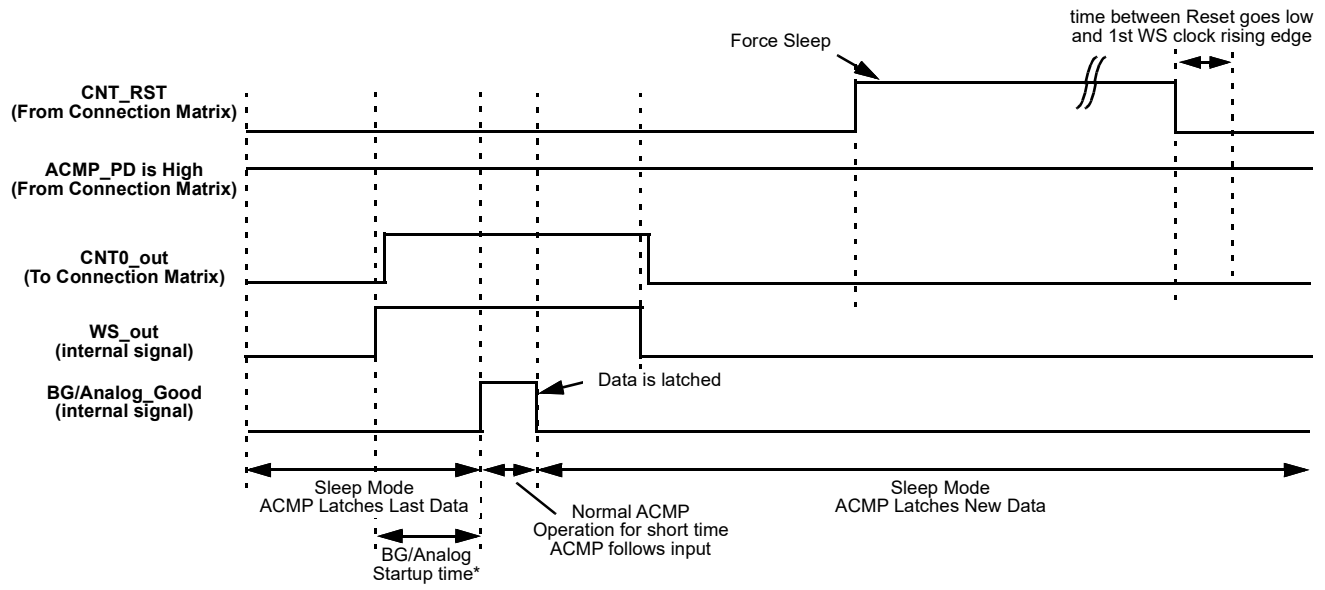

Figure 56: Wake and Sleep Timing Diagram, Short Wake Mode, Counter Set is Used

Note: If low power BG is powered on/off by WS, the wake time should be longer than 2.1 ms. The BG/analog start up time will take maximal 2 ms. If low power BG is always on, OSC0 period is longer than required wake time. The short wake mode can be used to reduce the current consumption. The short wake mode is edge triggered, when the wake signal is latched by rising edge and released the Power-On signal after the ACMP output data is latched. This allows to have a valid ACMP data for any type of wake signal and have the optimized current consumption.

GreenPAK Programmable Mixed-Signal Matrix with In-System Programmability and Advanced Analog Features

To use any ACMP under WS controller, the following settings must be done:

- CNT/DLY0 must be set to Wake and Sleep Controller function (for all ACMPs);
- Register WS => enable (for each ACMP separately);
- CNT/DLY0 set/reset input = 0 (for all ACMPs).

As the OSC any oscillator with any pre-divider can be used. The user can select a period of time while the ACMP is sleeping in a range of 1 - 65535 clock cycles. Before they are sent to sleep their outputs are latched, so the ACMPs remain their state (High or Low) while sleeping.

WS controller has the following settings:

- Wake and Sleep Output State (High/Low)
 - If OSC is powered off (Power-down option is selected; Power-down input = 1) and Wake and Sleep Output State = High, the ACMP is continuously on.
 - If OSC is powered off (Power-down option is selected; Power-down input = 1) and Wake and Sleep Output State = Low, the ACMP is continuously off.
 - Both cases WS function is turned off.
- Counter Data (Range: 1 to 65535)
 - User can select wake and sleep ratio of the ACMP; counter data = sleep time, one clock = wake time.
- Q mode - defines the state of WS counter data when Set/Reset signal appears
 - Reset - when active signal appears, the WS counter will reset to zero and High level signal on its output will turn on the ACMPs. When Reset signal goes out, the WS counter will go Low and turn off the ACMPs until the counter counts up to the end.
 - Set - when active signal appears, the WS counter will stop and Low level signal on its output will turn off the ACMPs. When Set signal goes out, the WS counter will go on counting and High level signal will turn on the ACMPs while counter is counting up to the end.

Note: The OSC0 matrix power down to control ACMP WS is not supported for short wait time option.

- Edge Select defines the edge for Q mode
 - High level Set/Reset - switches mode Set/Reset when level is High

Note: Q mode operates only in case of "High Level Set/Reset".

- Wake time selection - time required for wake signal to turn the ACMPs on

Normal Wake Time - when WS signal is High, it takes BG/analog start up time to turn the ACMPs on. They will stay on until WS signal is Low again. Wake time is one clock period. It should be longer than BG turn on time and minimal required comparing time of the ACMP.

Short Wake Time - when WS signal is High, it takes BG/analog start up time to turn the ACMPs on. They will stay on for 1 μ s and turn off regardless of WS signal. The WS signal width does not matter.

- Keep - pauses counting while Keep = 1
- Up - reverses counting
 - If Up = 1, CNT is counting up from user selected value to 65535.
 - If Up = 0, CNT is counting down from user selected value to 0.

9 Analog Comparators

9.1 ANALOG COMPARATORS OVERVIEW

There are two Low Power Rail-to-Rail General Purpose Analog Comparators (ACMP) macrocells in the SLG47004. For the ACMP macrocells to be used in a GreenPAK design, the power-up signals (ACMP0_L_pdb and ACMP1_L_pdb) need to be active. By connecting to signals coming from the Connection Matrix, it is possible to have each ACMP be ON continuously, OFF continuously, or switched on periodically, based on a digital signal coming from the Connection Matrix. When ACMP is powered down, its output is low. Two General Purpose Analog Comparators are optimized for low power operation.

Each of the General Purpose ACMP cells has a positive input signal that can be provided by a variety of external sources, and can also have a selectable gain stage (1x, 0.5x, 0.33x, 0.25x) before connection to the analog comparator. The gain divider is unbuffered and has an input resistance of 2 M Ω (typ) for 0.5x, 0.33x, 0.25x, and 10 G Ω for 1x. Each of the General Purpose ACMP macrocells has a negative input signal that is either created from an internal Vref or provided by any external source (from external pins). Note that the external Vref signal is filtered with a 2nd order low pass filter with 8 kHz typical bandwidth, see in [Figure 57](#) and [Figure 58](#).

Input bias current < 1 nA (typ).

PWR UP = 1 => ACMP is powered up.

PWR UP = 0 => ACMP is powered down.

Both General Purpose Analog Comparators have "Low Energy Power Up" setting (register [608] - ACMP0, register [630] - ACMP1). When enabled, it allows reducing average power consumption during ACMP power up process. This setting changes power up sequence of analog macrocells:

Low Energy Power Up register [608], register [630] = 0 - all analog macrocells associated with ACMP turns on simultaneously.

Low Energy Power Up register [608], register [630] = 1 - the first macrocell that begins to turn on is Bandgap. Other analog macrocells begin to turn on only after BG_OK signal is valid. This option slightly increases general ACMP Power-On time, while reducing the average current consumption.

During power-up, the ACMP output will remain LOW, and then becomes valid after power up signal goes high for ACMP0_L and ACMP1_L (see parameter t_{start} in [Table 17](#)).

Each cell also has a flexible hysteresis selection, to offer hysteresis of 32 steps, but not more than Vref voltage. It means that there are 6-bits to select Vref and independent 6-bits to select the hysteresis (no need to have an adder logic).

It's possible to enable low pass filter at the Vref input. But it's highly recommended to enable this LPF only when hysteresis $V_{hys} > 196$ mV.

ACMP0_L IN+ options are OA0_out, GPIOx (PIN), V_{DD}.

ACMP1_L IN+ options are OA1, GPIOx (PIN), ACMP0L_IN+, Temp Sensor OUT.

SLG47004

GreenPAK Programmable Mixed-Signal Matrix with In-System Programmability and Advanced Analog Features

9.1.1 ACMP0L Block Diagram

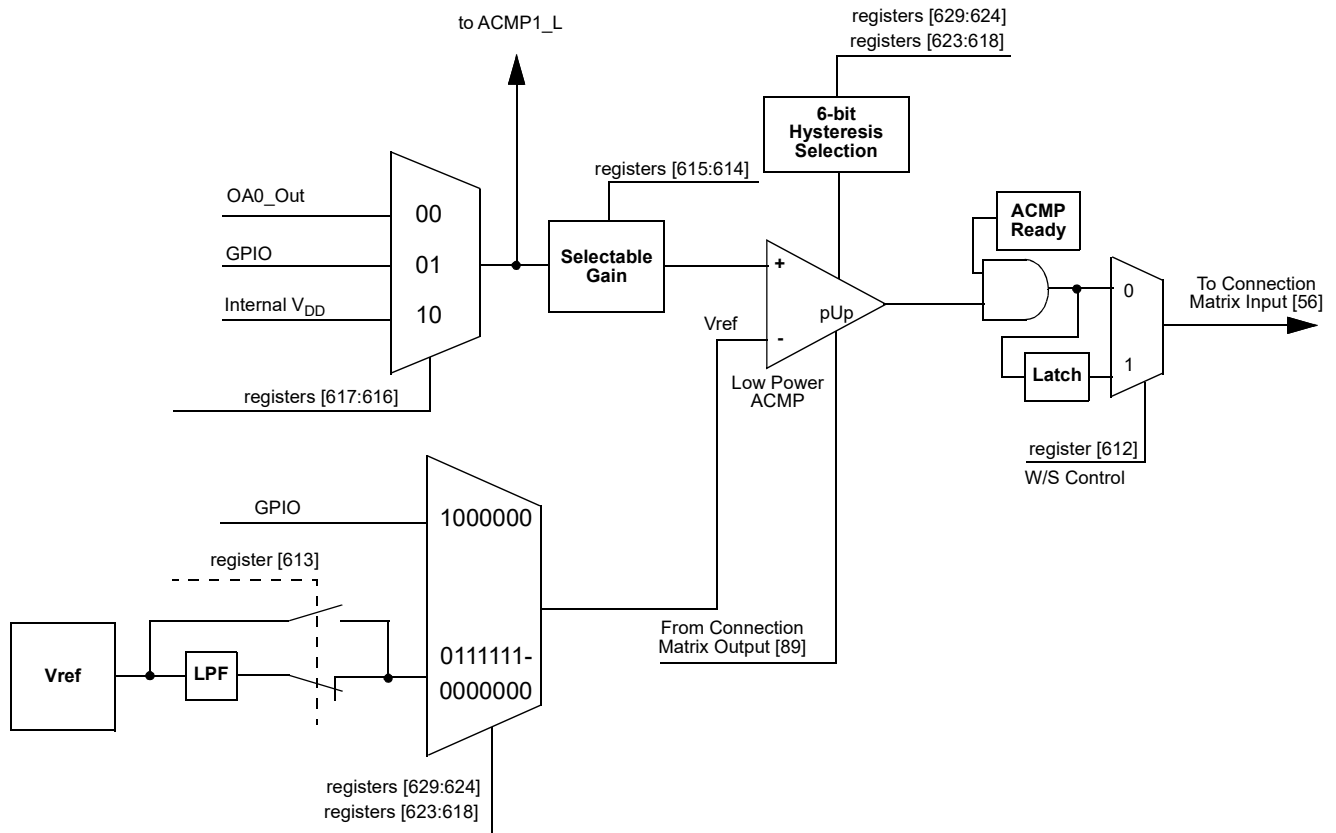

Figure 57: ACMP0L Block Diagram

SLG47004

GreenPAK Programmable Mixed-Signal Matrix with In-System Programmability and Advanced Analog Features

9.1.2 ACMP1L Block Diagram

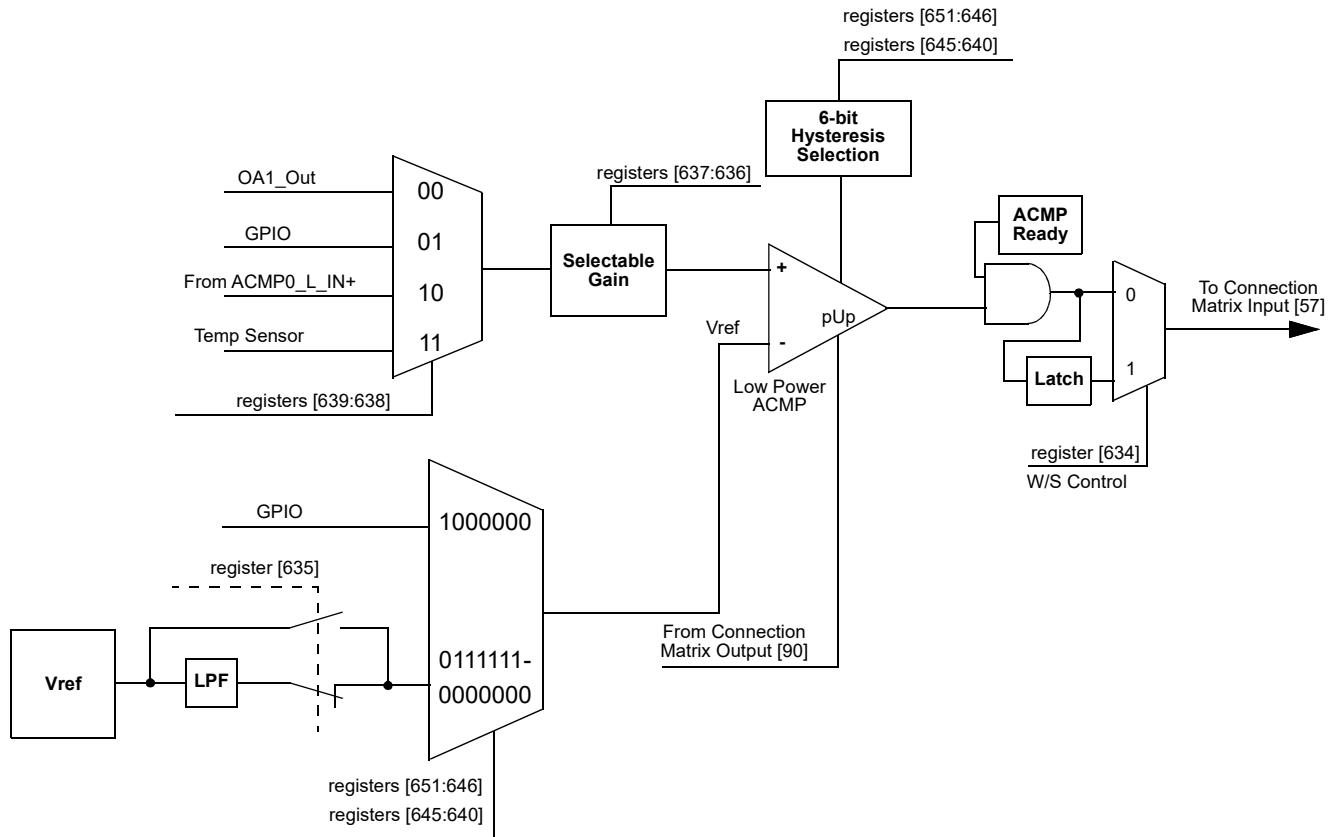

Figure 58: ACMP1L Block Diagram

9.2 CHOPPER ANALOG COMPARATOR

There is one Chopper Rail-to-Rail Analog Comparator (ACMP) macrocells in the SLG47004. It is possible to use Chopper ACMP to do in system trim by changing the Rheostat resistance in Auto-Trim mode. It is also possible to use a Chopper ACMP as a general purpose analog comparator.

The chopper ACMP power up signal is controlled either by internal Auto-Trim logic (Set 0/1 of Digital Rheostat 0/1) or by matrix input.

The chopper ACMP is automatically powered on during the calibration time to control the up/down signal of the counter/rheostat, when the Auto-Trim is enabled (register [909]= 0).

In order to use Chopper ACMP as a standalone comparator (Auto-Trim mode is disabled, register [909] = 1) user should provide the clock signal to this macrocell. Clock source can be internal oscillators or any pulses from the connection matrix.

Note that clock frequency for the Chopper ACMP shouldn't be greater than f_{ChACMP} . Please refer to Table 24.

For proper Chopper ACMP operation it is recommended to force the bandgap on. It's highly recommended to force the bandgap on when OSC1 is used as a clock source for Chopper ACMP. Also, if Vref (bandgap) is used in the project, internal Vref should be stable before the 2nd rising edge of Chopper ACMP clock signal (see Figure 59). Please consider the bandgap turn on delay (approximately 1 ms).

Output of Chopper ACMP can be optionally inverted by register [882].

The matrix output [85] is used to control chopper ACMP power up signal for the general purpose usage, see Figure 59. It is

GreenPAK Programmable Mixed-Signal Matrix with In-System Programmability and Advanced Analog Features

possible to use the chopper ACMP as a general purpose ACMP after Auto-Trim procedure is completed, since the power up signal is a logic OR of the latched Set (Digital Rheostat 0/1) signal and matrix signal. If Auto-Trim (Set 0/1 of Digital Rheostat 0/1) is disabled and chopper ACMP channel is set to Auto (Channel 0/1), then ACMP output defaults to Channel 0 while Channel 1 is ignored.

The power-up signals need to be active high in order to use the Chopper ACMP. By connecting to signals coming from the Connection Matrix, it is possible to have ACMP be ON continuously, OFF continuously, or switched on periodically based on a digital signal coming from the Connection Matrix. When ACMP is powered down, its output is low.

There are no Gain and Hysteresis selection for chopper ACMP compared to the ACMP0L and ACMP1L.

It's possible to select different reference sources for Chopper ACMP. It can be:

- external voltage from pin;
- divided internal voltage from internal reference source (from 32 mV to 2048 mV);
- divided internal reference voltage from HD Buffer (64 steps);
- divided V_{DDA} voltage (64 steps).

For more information see Section 15.

The positive input of the Chopper ACMP can be connected to the Op Amp0 out or Op Amp1 out or In Amp out, or to the external PIN.

The inputs of Chopper ACMP can be reconfigured while operating in AutoTrim mode. There is one configuration of inputs (Figure 59) for case when Set0 (Digital Rheostat 0) signal is latched, and another configuration of Chopper ACMP inputs when Set1 (Digital Rheostat 1) signal is latched. For example, M1 MUX can be configured to operate with In Amp out when Set0 (Digital Rheostat 0) is latched and Chopper_ACMP+ pin when Set1 (Digital Rheostat 1) is latched. The same way, "-" input of Chopper ACMP can be configured to work with any of possible inputs when Set0 (Digital Rheostat 0) or Set1 (Digital Rheostat 1) are latched.

Note that the default configuration is the configuration for Set0 (Digital Rheostat 0) signal. When Chopper ACMP operates as separate ACMP and AutoTrim function is disabled, inputs of Chopper ACMP are defined by registers [893:892].

Note that Chopper ACMP will automatically enable HD Buffer if HD Buffer is selected as a source for Chopper ACMP In-signal (register 946 = 0) and Chopper ACMP is powered up.

SLG47004

GreenPAK Programmable Mixed-Signal Matrix with In-System Programmability and Advanced Analog Features

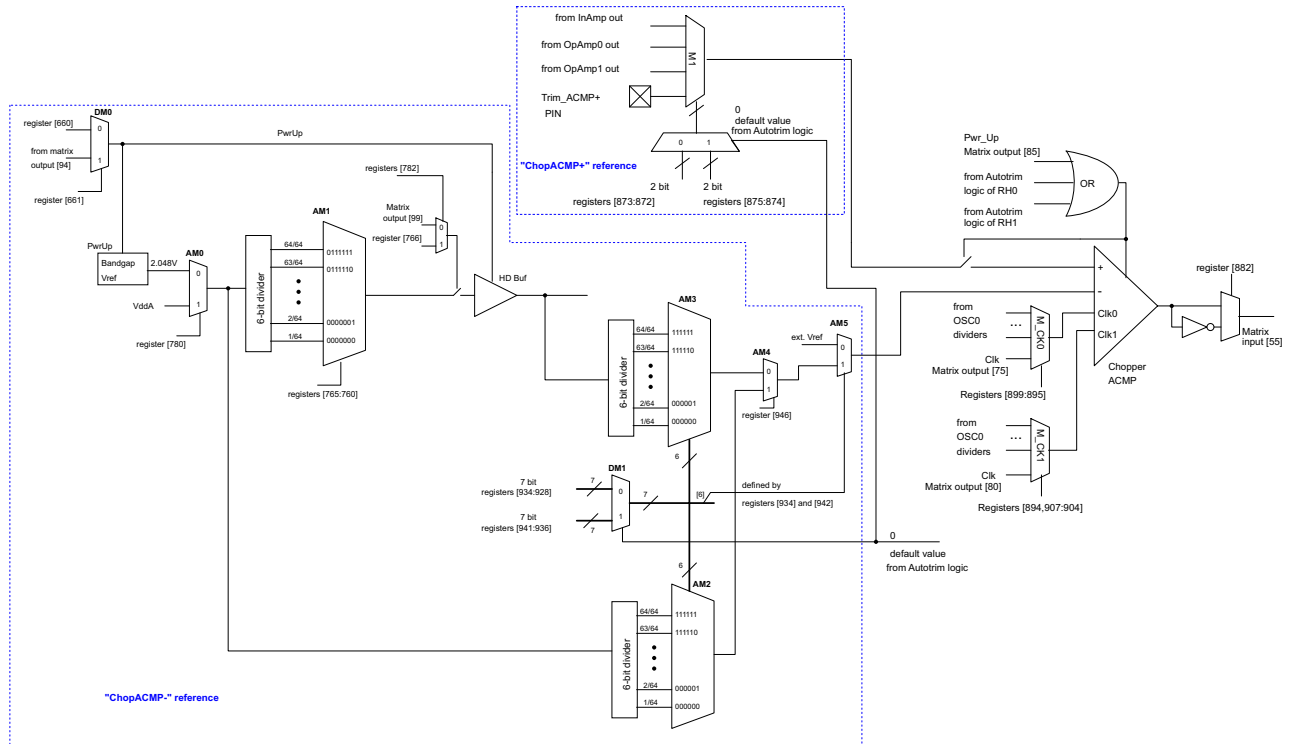

Figure 59: Chopper ACMP Block Diagram

9.3 ACMP SAMPLING MODE

Both General Purpose Analog Comparators (ACMPL0 and ACMPL1) have an optional sampling mode. In this mode, ACMP is enabled for the shortest amount of time after rising edge at Power Up input to get a valid data. Then ACMP latches its value and goes sleep again.

Registers [610], [632] enable sampling mode for two comparators.

SLG47004

GreenPAK Programmable Mixed-Signal Matrix with In-System Programmability and Advanced Analog Features

9.4 ACMP TYPICAL PERFORMANCE

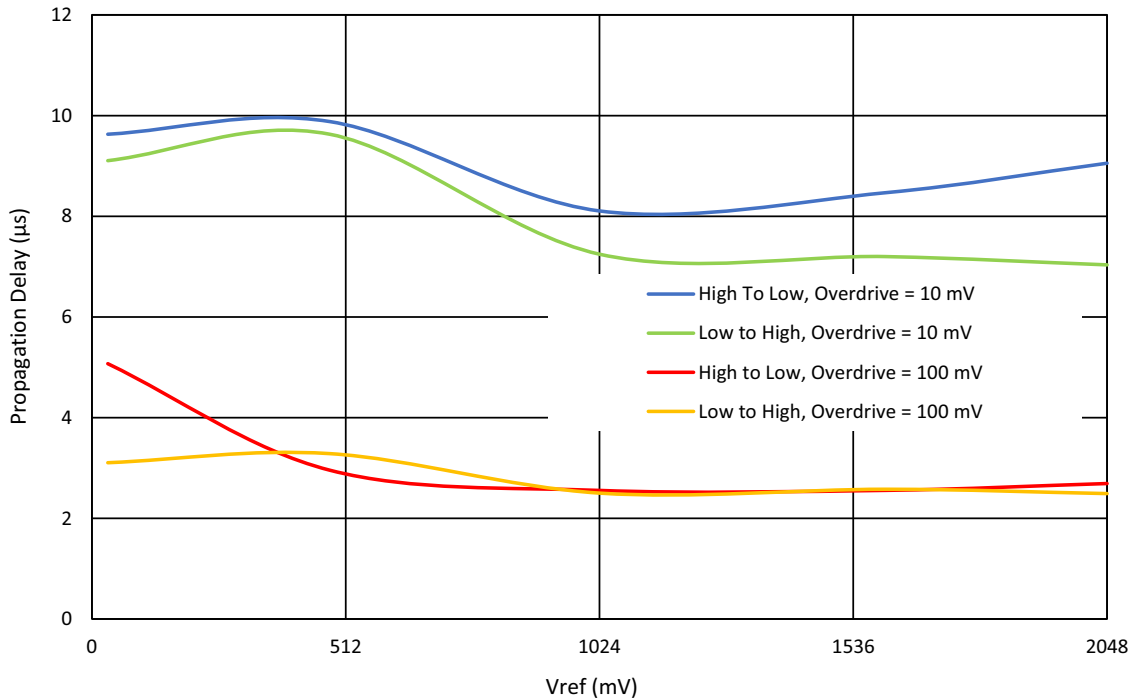

Figure 60: Propagation Delay vs. Vref for ACMPx at T = 25 °C, V_{DD} = 2.4 V to 5.5 V, Hysteresis = 0

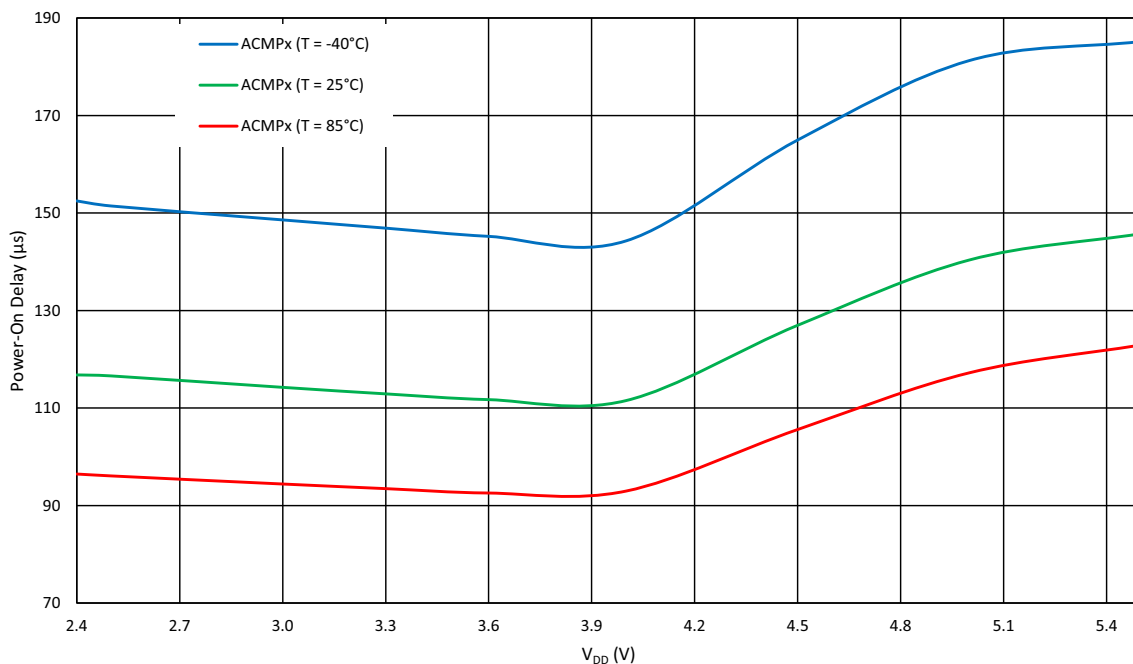

Figure 61: ACMPx Power-On Delay vs. V_{DD} at BG - Forced

SLG47004

GreenPAK Programmable Mixed-Signal Matrix
with In-System Programmability and Advanced Analog Features

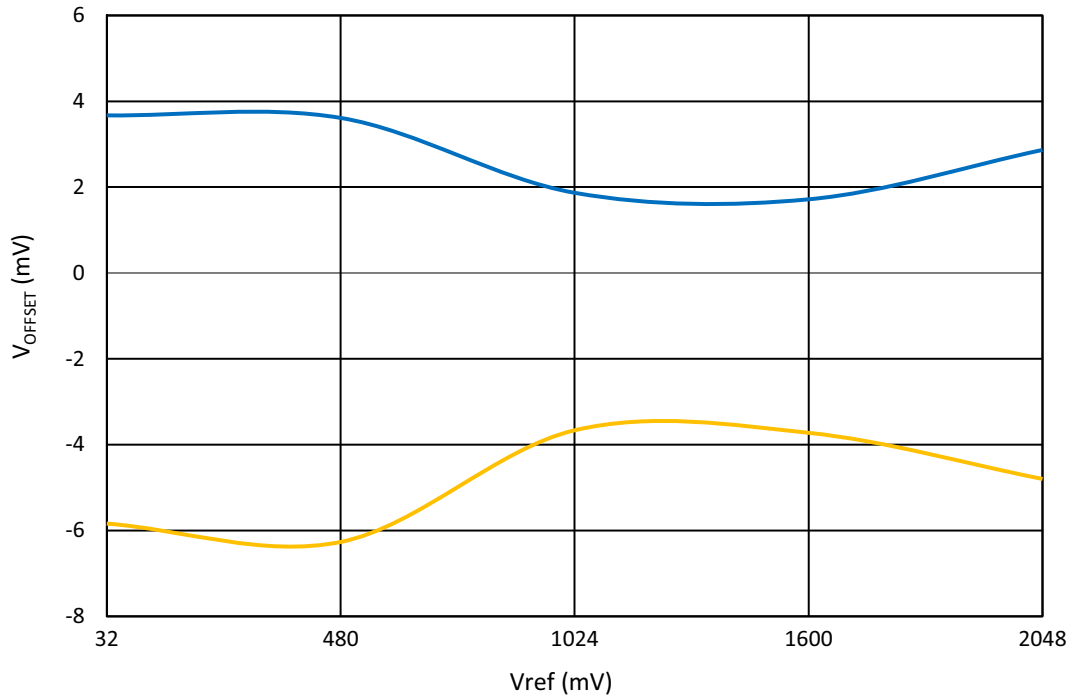

Figure 62: ACMPx Input Offset Voltage vs. Vref at T = -40 °C to 85 °C, V_{DD} = 2.4 V to 5.5 V, Gain = 1

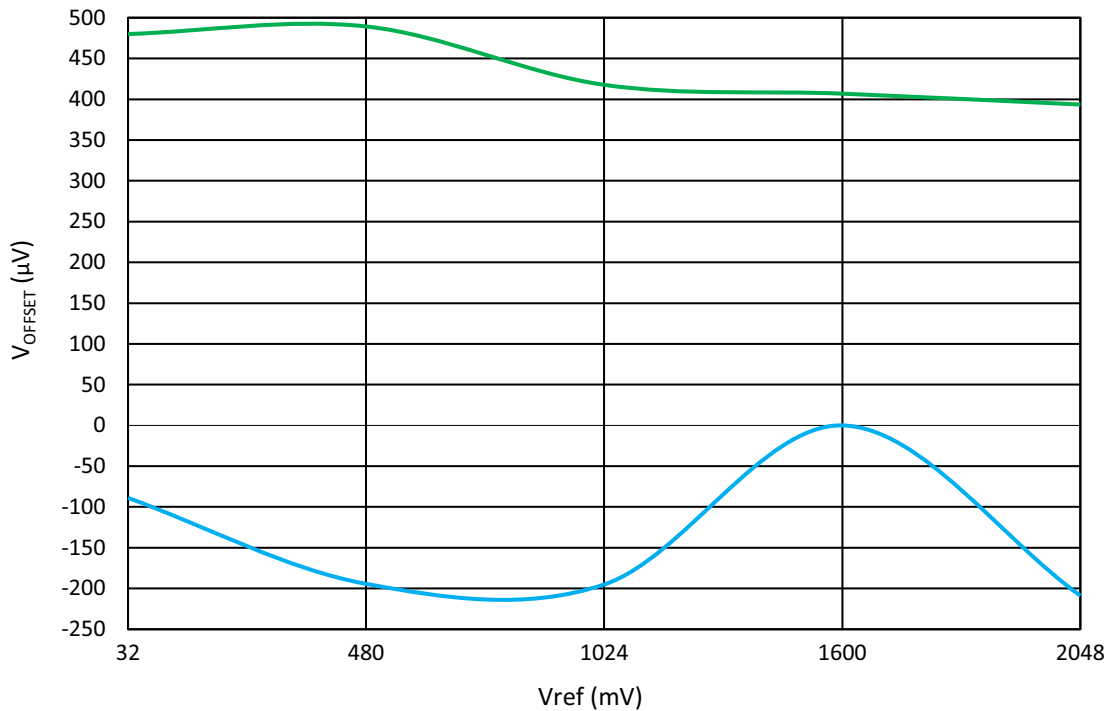

Figure 63: Chopper ACMP Input Offset Voltage vs. Vref at T = -40 °C to 85 °C, V_{DD} = 2.4 V to 5.5 V, Gain = 1

SLG47004

GreenPAK Programmable Mixed-Signal Matrix
with In-System Programmability and Advanced Analog Features

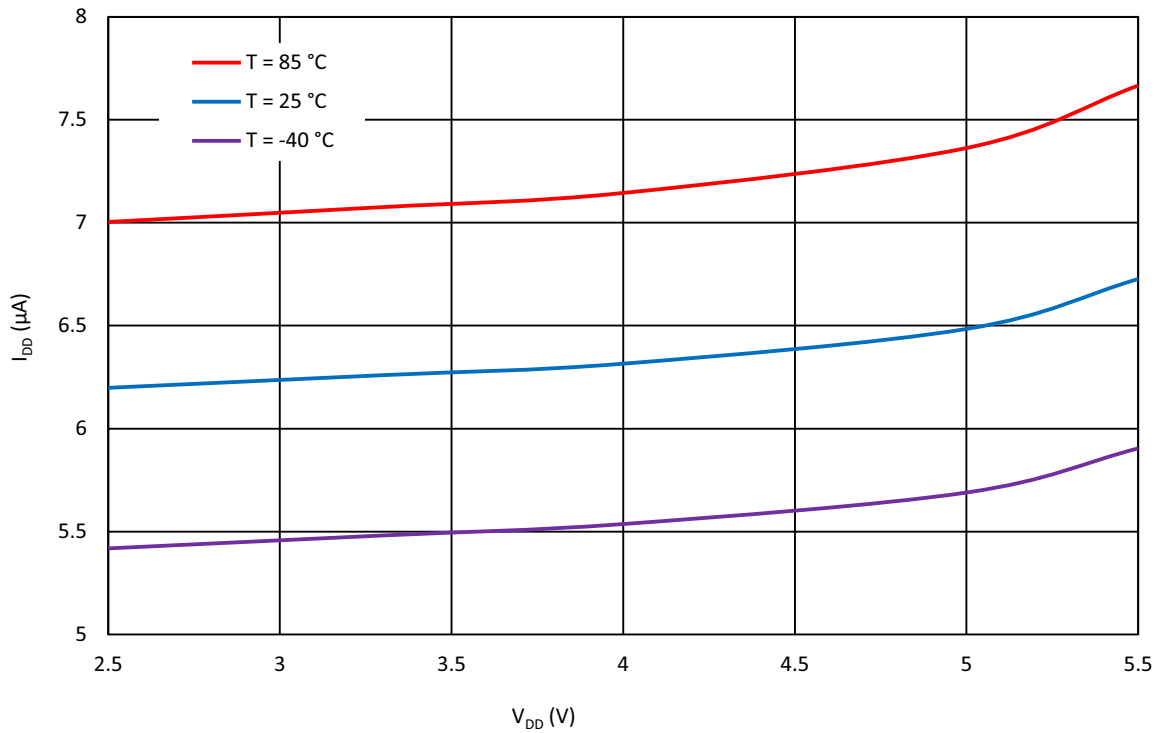

Figure 64: ACMPx Current Consumption vs. V_{DD}

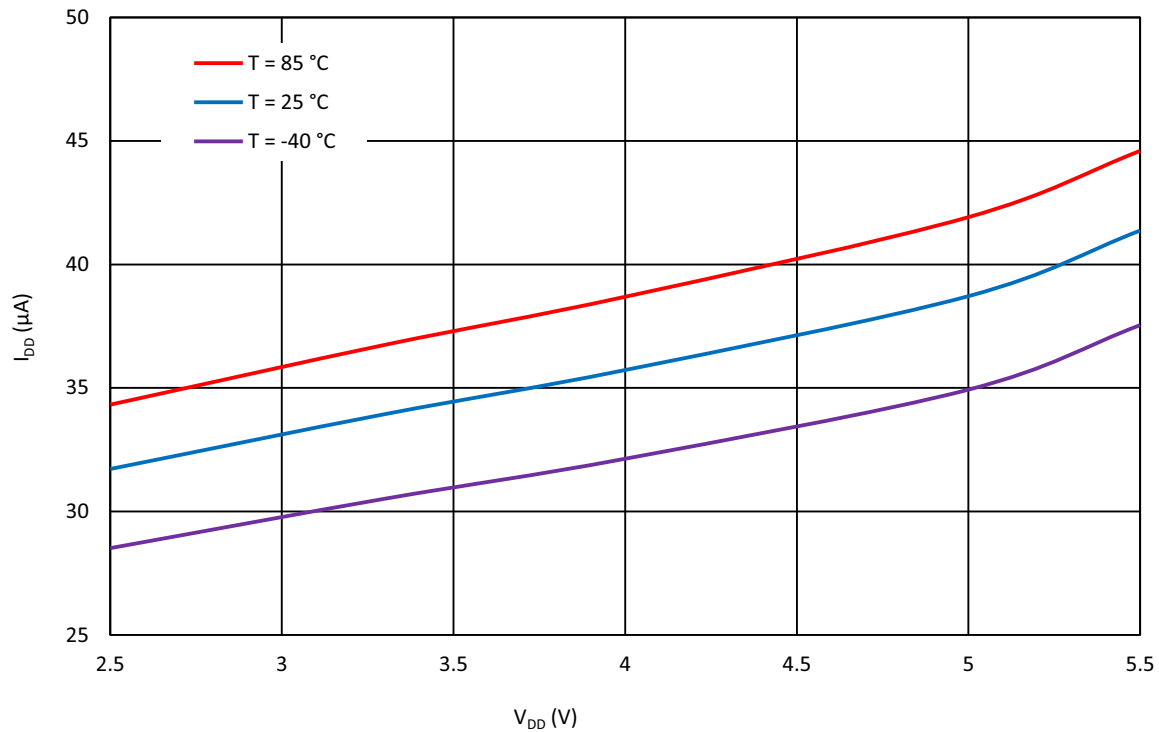

Figure 65: Chopper ACMP Current Consumption vs. V_{DD} (with 2.048 kHz Clock)

SLG47004

GreenPAK Programmable Mixed-Signal Matrix with In-System Programmability and Advanced Analog Features

10 Programmable Operational Amplifiers

10.1 GENERAL DESCRIPTION

The SLG47004 contains three operational amplifiers with rail-to-rail input and output. Two of them (Programmable Op Amps) have the additional functions of driving internal analog FETs (Voltage Regulator and Current Sink modes) and Comparator mode. The third Internal Op Amp is an amplifier with internal resistors, and can be configured as a difference amplifier with Gain = 1. All three op amps can function as instrumentation amplifiers. The structures of the op amps are shown in Figure 66 and Figure 67.

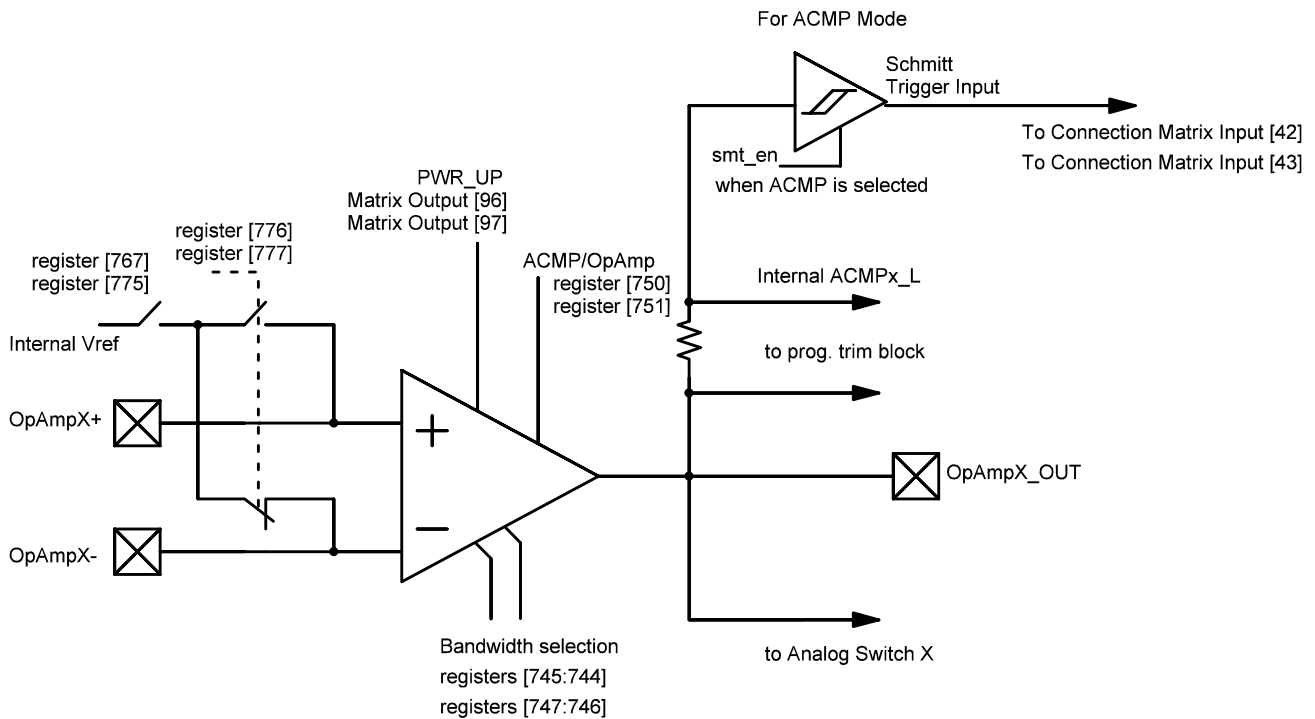

Figure 66: Programmable Operational Amplifier OA0, OA1 Internal Circuit

SLG47004

GreenPAK Programmable Mixed-Signal Matrix with In-System Programmability and Advanced Analog Features

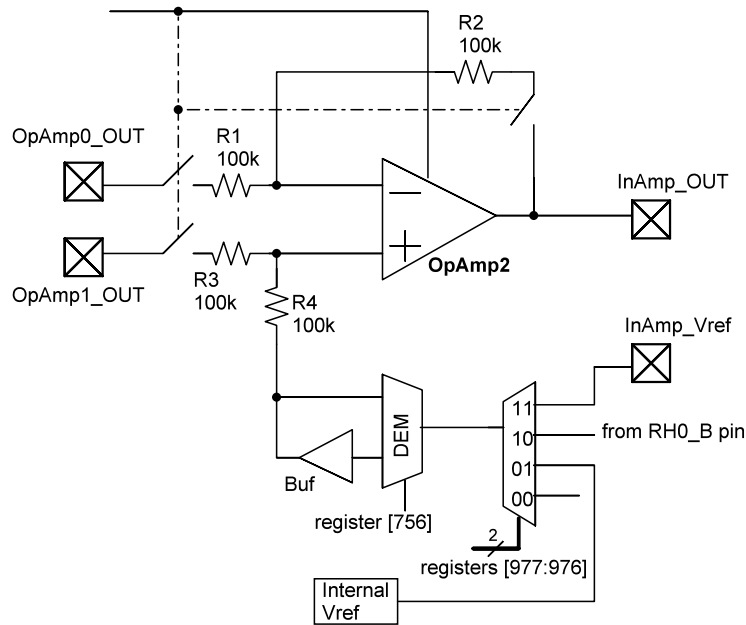

Figure 67: Internal Operational Amplifier Circuit

Each of the two Programmable Op Amp inputs has a hardware connection to the external pin and an optional connection to the internal voltage reference source, which makes it possible to create precise voltage or current source. For more detailed description of op amp Vref sources see Section 15. The output of the operational amplifier is hardwired to an external pin. This output can also be connected to the Programmable Trim block of rheostat macrocell, ACMP non-inverting input (ACMP0_L+ for OA0, ACMP1_L+ for OA1), or control the corresponding Analog Switch, depending on the mode of operation. Each Programmable Op Amp can also be configured as an analog comparator, in which case its output signal is connected to the Connection Matrix through a dedicated buffer.

Each Programmable Op Amp has a programmable bandwidth that can be set by two register bits. In addition, internal charge pump setting for each Op Amp must be changed according to bandwidth selection, see Table 55.

Internal charge pump can be disabled if input common-mode voltage $V_{CM} < (V_{DDA} - 1.5 V)$. But it is strongly recommended to keep the default setting (enable charge pump).

The bandwidths may vary up to +/-30 % over PVT. Each operational amplifier is factory trimmed. This trimming is independent of the trimming associated with the onboard digital rheostat (system calibration).

The Internal operational amplifier shares its inputs with the Programmable Op Amps outputs. The voltage reference for the internal amplifier can be sourced from either the internal or external Vref. Note that if the internal Vref is used as a source for the instrumentation amplifier Vref, the user can optionally connect this Vref to the output pin, or disconnect the Vref from output pin and use this pin as GPIO.

Also, if the Internal Op Amp is inactive (In Amp Mode is disabled), the user can use the In Amp_Vref pin as GPIO. The In Amp_Out pin can be configured as GPI.

Table 55: Op Amp Bandwidth Settings

Op Amp Bandwidth Selection	Op Amp0				Op Amp1				Op Amp2 (Internal)			
	Bandwidth Selection		Charge Pump Frequency		Bandwidth Selection		Charge Pump Frequency		Bandwidth Selection		Charge Pump Frequency	
Register Bit →	745	744	955	954	747	746	963	962	749	748	971	970
128 kHz	0	0	0	0	0	0	0	0	0	0	0	0
512 kHz	0	1	0	1	0	1	0	1	0	1	0	1
2.048 MHz	1	0	1	0	1	0	1	0	1	0	1	0
8.192 MHz	1	1	1	1	1	1	1	1	1	1	1	1

SLG47004

GreenPAK Programmable Mixed-Signal Matrix with In-System Programmability and Advanced Analog Features

10.2 MODES OF OPERATION

In order to use any of the op amp macrocells in the GreenPAK Designer, the power up signal (PWR_UP) must be set to logic High. By default, all op amp macrocells are turned off after SLG47004 startup. During power-up, outputs of all op amps will remain in a Hi-Z state and then become valid (see parameter t_{on} in Table 23).

Operational amplifiers turn-on time can be decreased by setting register bits [759:757] to 1. In this case op amps analog supporting blocks are always turned on. Note that current consumption of op amp will be increased when op amp is powered down and bits [759:757] is 1 (see Section 3.13).

See the list below for the op amp operation modes:

- Operational Amplifier mode;
- Instrumentation Amplifier mode;
- Analog Comparator mode;
- Voltage Regulator mode;
- Current Sink mode.

10.2.1 Operational Amplifier Mode

In this mode, the Programmable Op Amp operates as a conventional operational amplifier. Also, the Programmable Op Amp can source the corresponding non-inverting ACMP input (see ACMP macrocell settings). The output of the Programmable Op Amp macrocell is in a Hi-Z state while the macrocell is turned off.

Figure 68 shows the example of differential amplifier with input offset voltage compensation with help of digital rheostat and programmable trim block. Zero input voltage equal to output voltage $V_{OUT} = V_{DD}/2$.

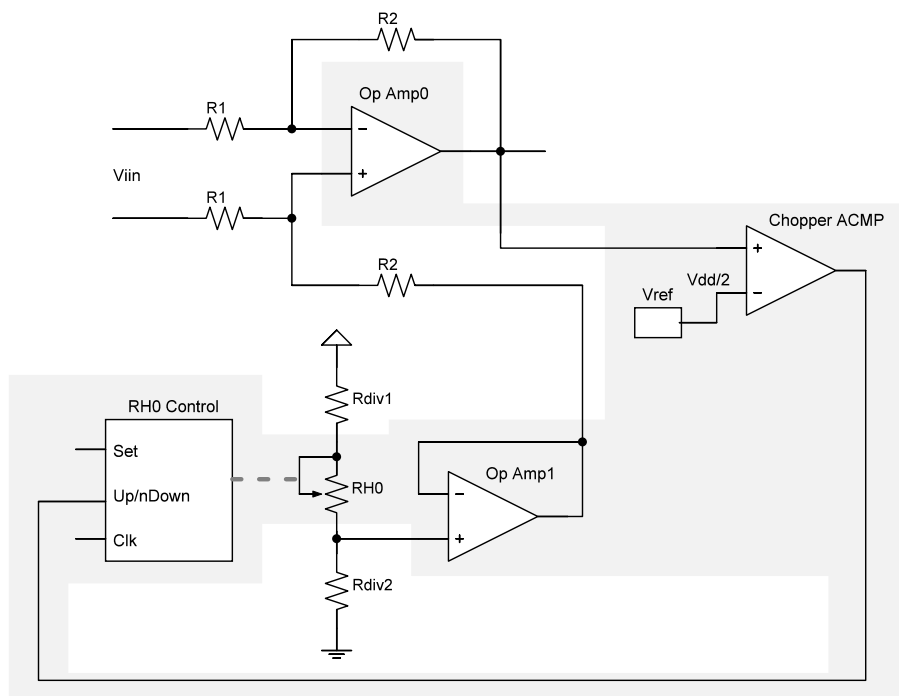

Figure 68: Example of Input Offset Voltage Compensation

10.2.2 Instrumentation Amplifier Mode

If this mode is active (Matrix Output [98] is High level), the two Programmable Op Amps and the single Internal Op Amp work together in Instrumentation Amplifier configuration, shown in Figure 69. When power up signal is logic LOW the output of In Amp is in Hi-Z state.

SLG47004

GreenPAK Programmable Mixed-Signal Matrix with In-System Programmability and Advanced Analog Features

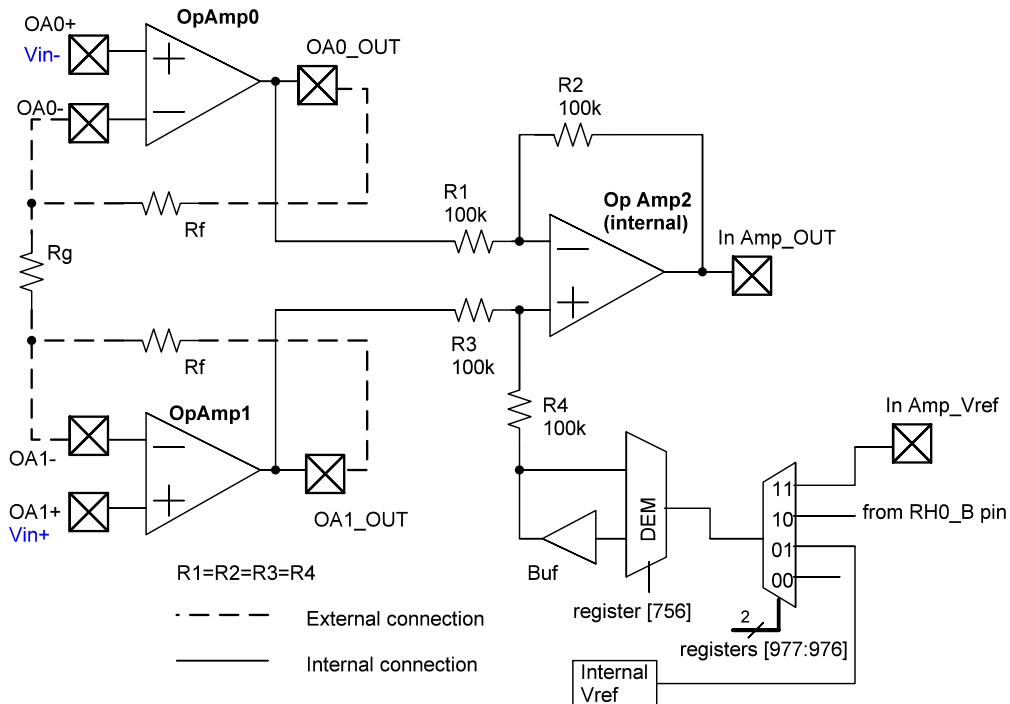

Figure 69: Instrumentation Amplifier Structure

The absolute value of internal resistors R₁, R₂, R₃, R₄ is 100 kΩ. The resistors R_f and R_g are user defined external resistors. The output voltage V_{OUT} of the instrumentation amplifier shown in Figure 69 is

$$V_{OUT} = (1 + 2R_f / R_g)(V_{IN+} - V_{IN-}) + V_{REF}$$

The user can trim both the gain and the offset error of the instrumentation amplifier using two of the Rheostats from the SLG47004. Figure 70 shows the configuration of the instrumentation amplifier in this scenario.

SLG47004

GreenPAK Programmable Mixed-Signal Matrix with In-System Programmability and Advanced Analog Features

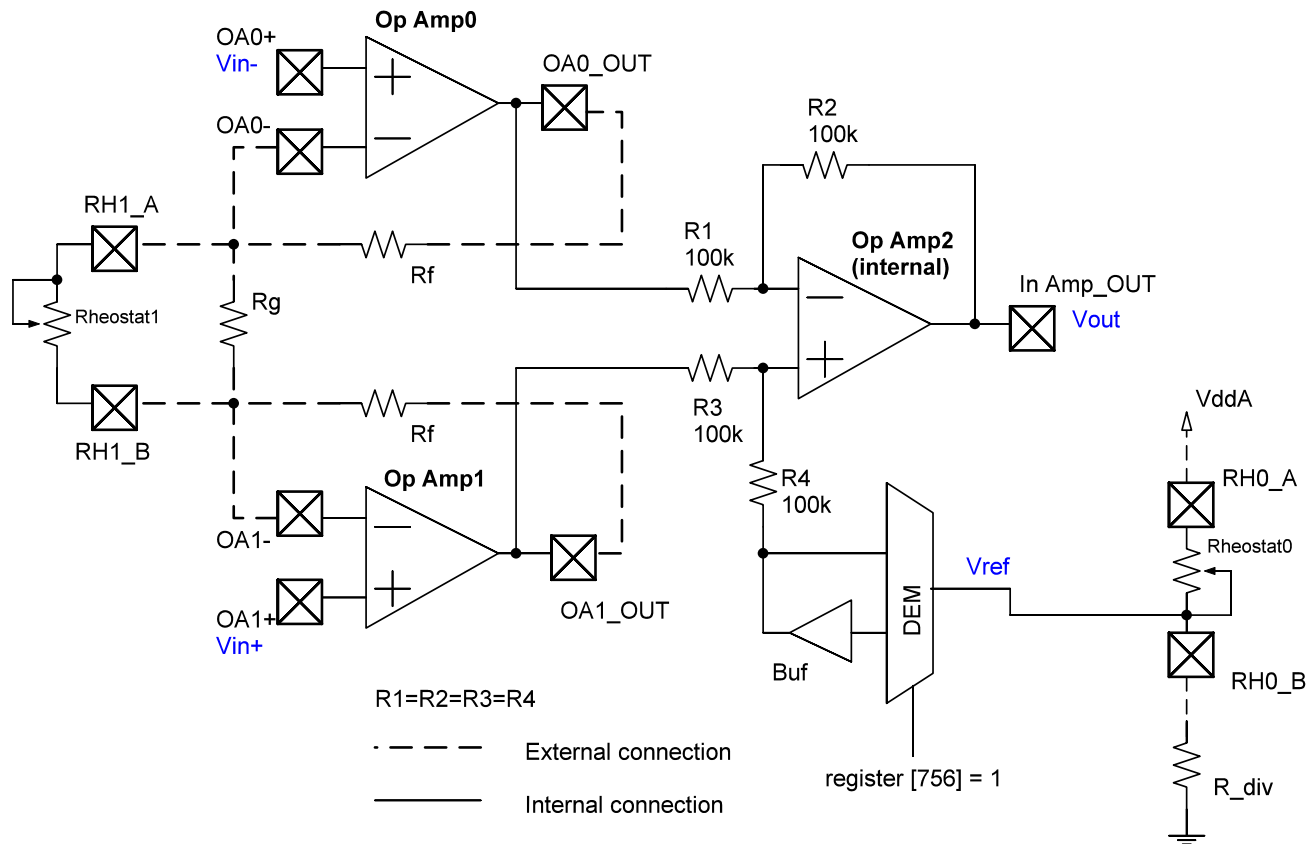

Figure 70: Instrumentation Operational Amplifier Configuration for Users Trim

Note that in Figure 70, the Demux connects to the Vref external input with an internal buffer (register [756] = 1). This allows us to eliminate the influence of resistor divider R_{div} and Rheostat0 on instrumentation amplifier.

It is possible to use a built-in Auto-Trim function for either setting the zero point of the Wheatstone bridge sensor using the In Amp or tuning a system output voltage to the desired level. However, the following limitations exist for using the built-in Auto-Trim function to trim both total system offset and system gain errors:

- The Auto-Trim procedures of total offset compensation and system gain error must be done iteratively starting and finishing with the total offset compensation: 1st iteration - offset compensation, 2nd iteration - gain trim, 3rd iteration - offset compensation. Extra iterations can be added to achieve a better accuracy. The last iteration should be an offset compensation.
- Total system offset (sensor offset + Op Amp1 offset + Op Amp2 offset) must not be greater than V_{sensor_output_range}/2.

It's possible to power external components like bridge or ADC from internal HD Buffer of SLG47004 to improve accuracy of system.

10.2.3 Analog Comparator Mode

Both operational amplifiers have an Analog Comparator mode in which they work as conventional rail-to-rail comparators.

10.2.4 Voltage Regulator Mode

In this mode, the op amp output drives P-FET (part of Analog Switch). Note that FETs of Analog Switches have different resistances. Analog Switch 0 has R_{ds_PMOS} << R_{ds_NMOS}, while Analog Switch 1 has R_{ds_NMOS} << R_{ds_PMOS}. That's why it is recommended to implement voltage regulator mode using Analog Switch 0. In this mode the op amp output is High when the macrocell is turned off. Figure 71 (A) shows the typical implementation of the voltage source function. Optionally, the

SLG47004

GreenPAK Programmable Mixed-Signal Matrix with In-System Programmability and Advanced Analog Features

user can use this mode to implement a constant current source with load connected to ground (Figure 71, B, C). Note that op amp must operate in operational amplifier mode (register 750 = 0 for Op Amp0, register 751 = 0 for Op Amp1).

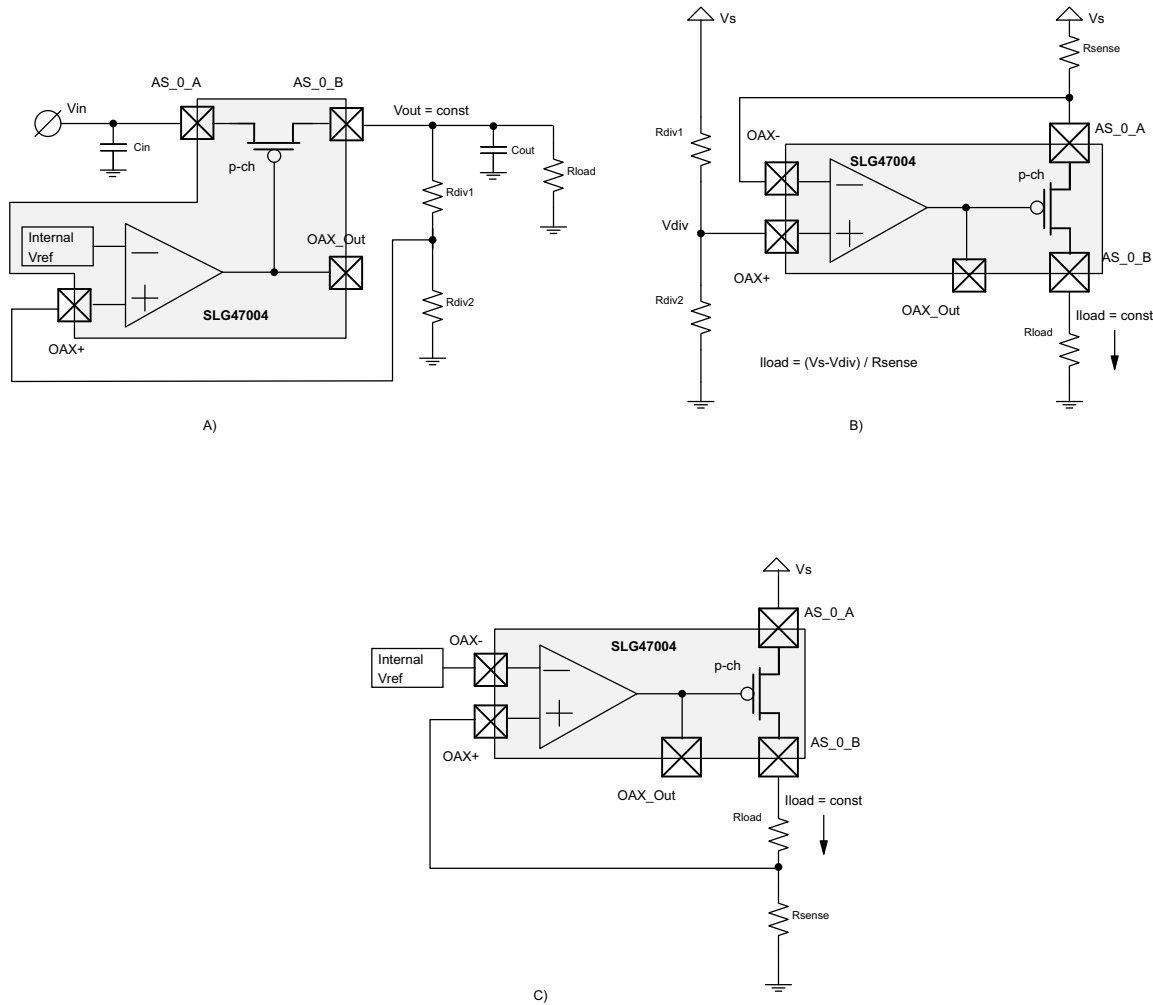

Figure 71: Typical Implementation of Voltage Regulator (A) and Current Sources (B, C)

Note that in this mode only an enhanced P channel FET of An_Sw_0 is used.

10.2.5 Current Sink Mode

Also, the op amp output can drive the N-FET (part of the Analog Switch) in order to implement a constant current sink. Note that FETs of Analog Switches have different resistances. Analog Switch 0 has $R_{ds_PMOS} \ll R_{ds_NMOS}$, while Analog Switch 1 has $R_{ds_NMOS} \ll R_{ds_PMOS}$. That's why it is recommended to implement current sink mode using Analog Switch 1. In this mode, the op amp output is LOW when the macrocell is turned off. Figure 72 shows a typical implementation of this Current Sink Function. Note that op amp must operate in operational amplifier mode (register 750 = 0 for Op Amp0, register 751 = 0 for Op Amp1).

SLG47004

GreenPAK Programmable Mixed-Signal Matrix with In-System Programmability and Advanced Analog Features

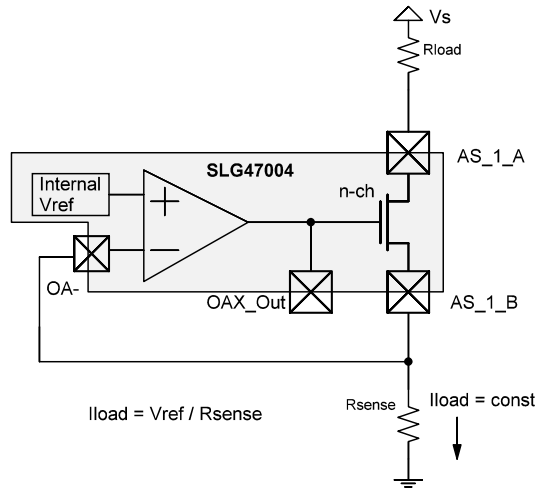

Figure 72: Constant Current Sink

Note that in this mode only an enhanced N channel FET of An_Sw_1 is used.

10.3 OP AMPS TYPICAL PERFORMANCE

$T_A = 25\text{ }^\circ\text{C}$, $V_{DDA} = 5.0\text{ V}$, $V_{SS} = \text{GND}$, $CM = V_{DD}/2$, $V_{OUT} = V_{DD}/2$, $V_L = V_{DD}/2$, $R_L = 1\text{ M}\Omega$ to V_L , $C_L = 80\text{ pF}$, unless otherwise stated.

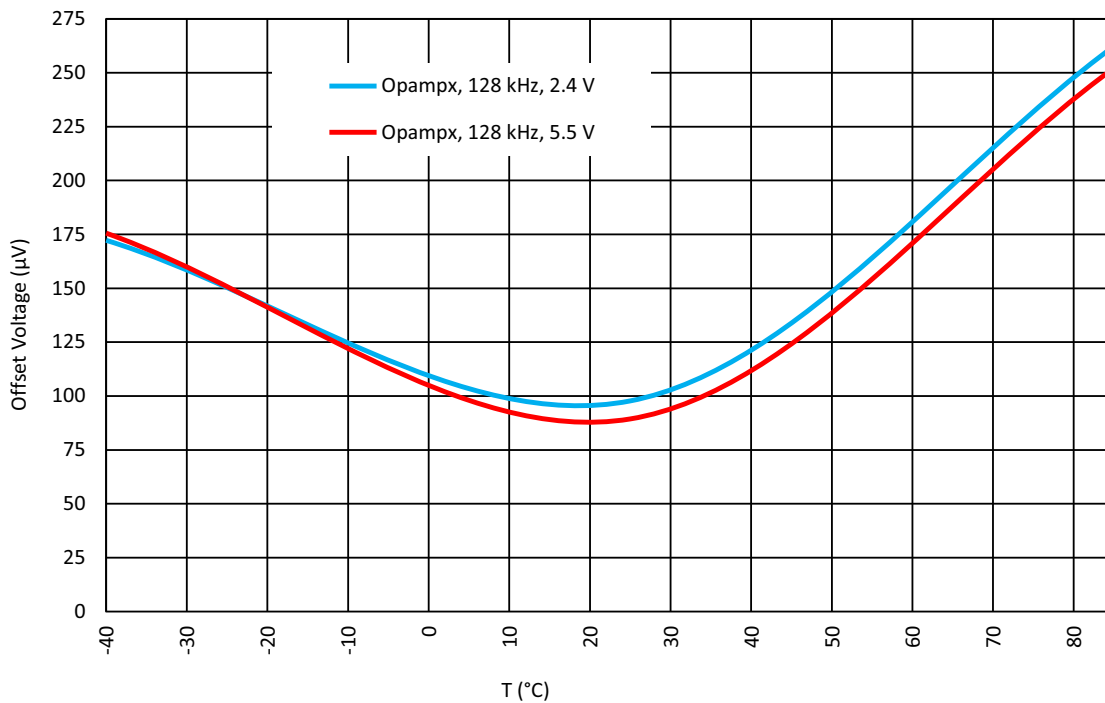

Figure 73: Op Ampx Input Offset Voltage vs. T_A at Input CM Voltage = $V_{DD}/2$, BW = 128 kHz

SLG47004

GreenPAK Programmable Mixed-Signal Matrix with In-System Programmability and Advanced Analog Features

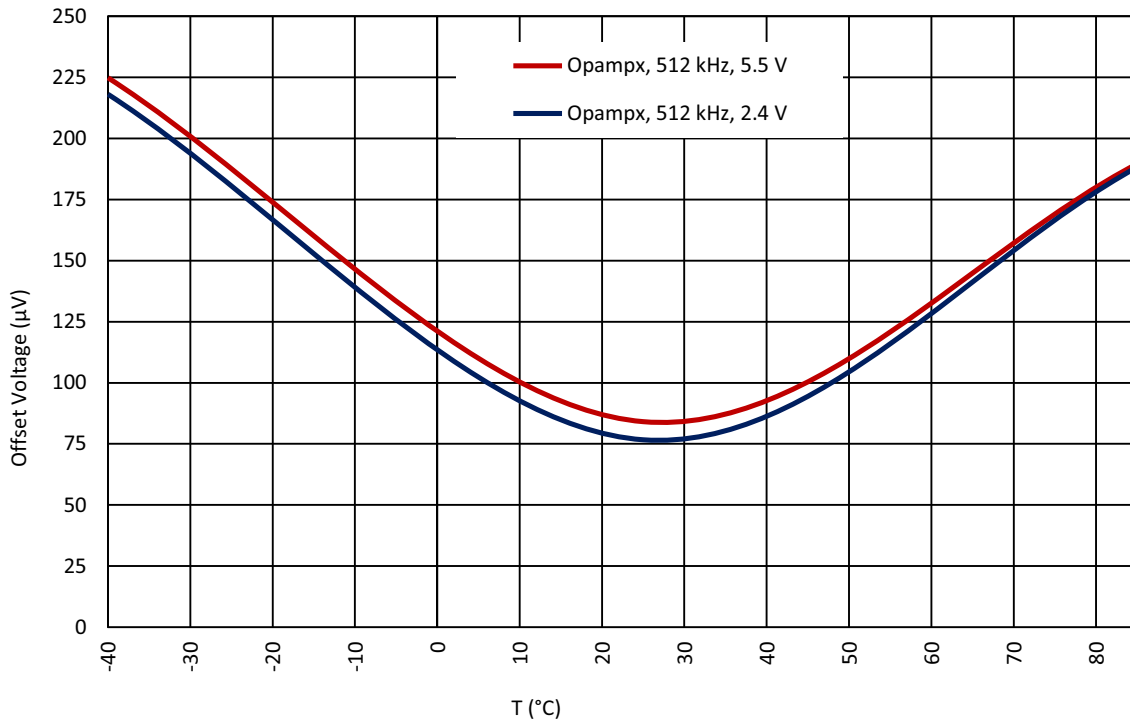

Figure 74: Op Ampx Input Offset Voltage vs. T_A at Input CM Voltage = $V_{DD}/2$, BW = 512 kHz

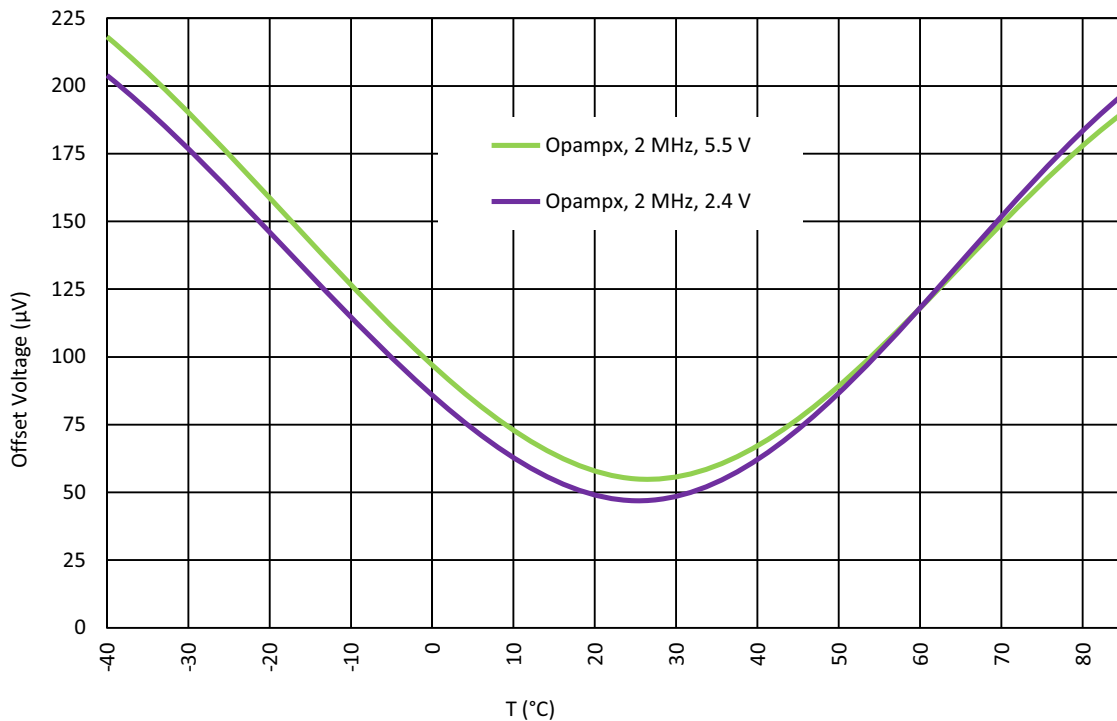

Figure 75: Op Ampx Input Offset Voltage vs. T_A at Input CM Voltage = $V_{DD}/2$, BW = 2 MHz

SLG47004

GreenPAK Programmable Mixed-Signal Matrix
with In-System Programmability and Advanced Analog Features

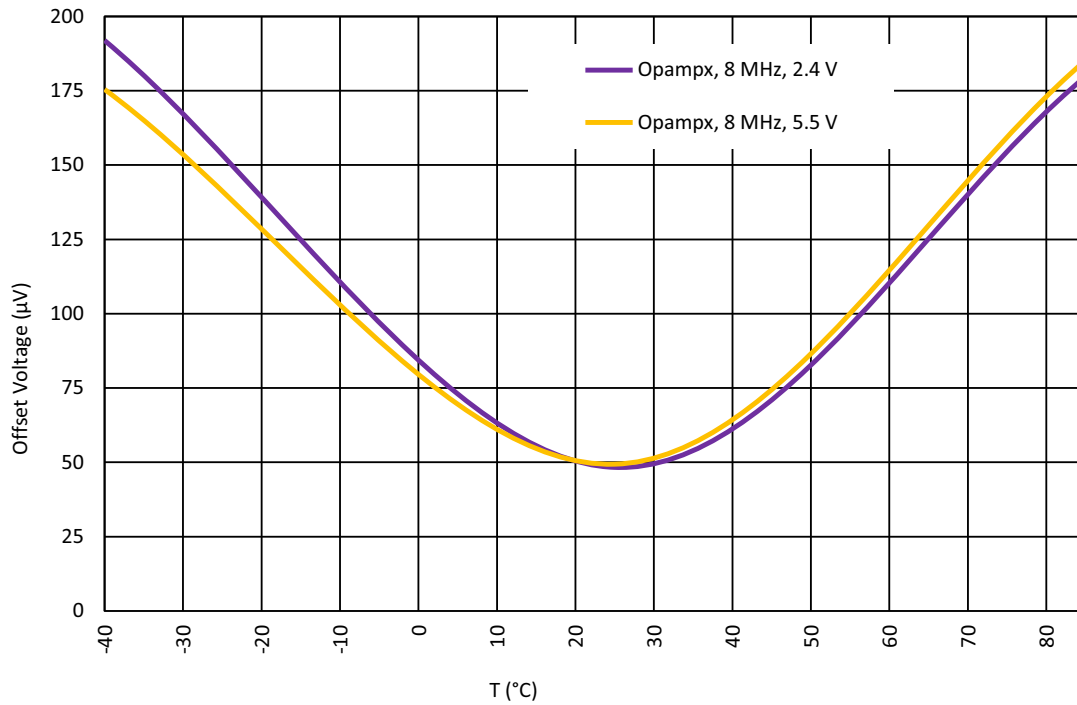

Figure 76: Op Ampx Input Offset Voltage vs. T_A at Input CM Voltage = $V_{DD}/2$, BW = 8 MHz

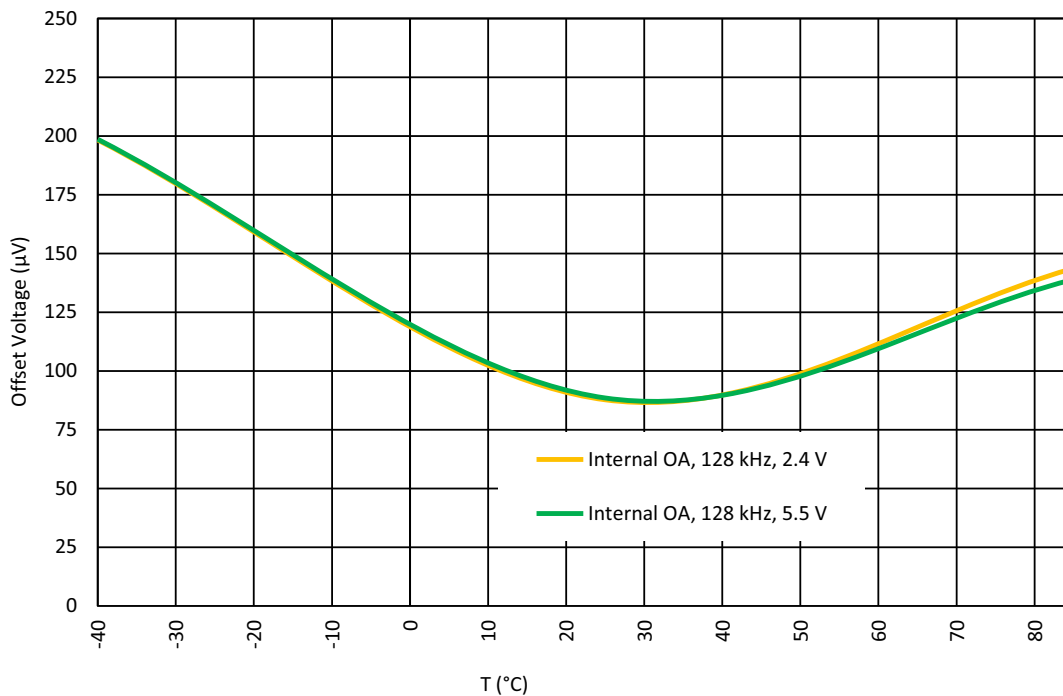

Figure 77: Internal Op Amp Input Offset Voltage vs. T_A at Input CM Voltage = $V_{DD}/2$, BW = 128 kHz

SLG47004

GreenPAK Programmable Mixed-Signal Matrix
with In-System Programmability and Advanced Analog Features

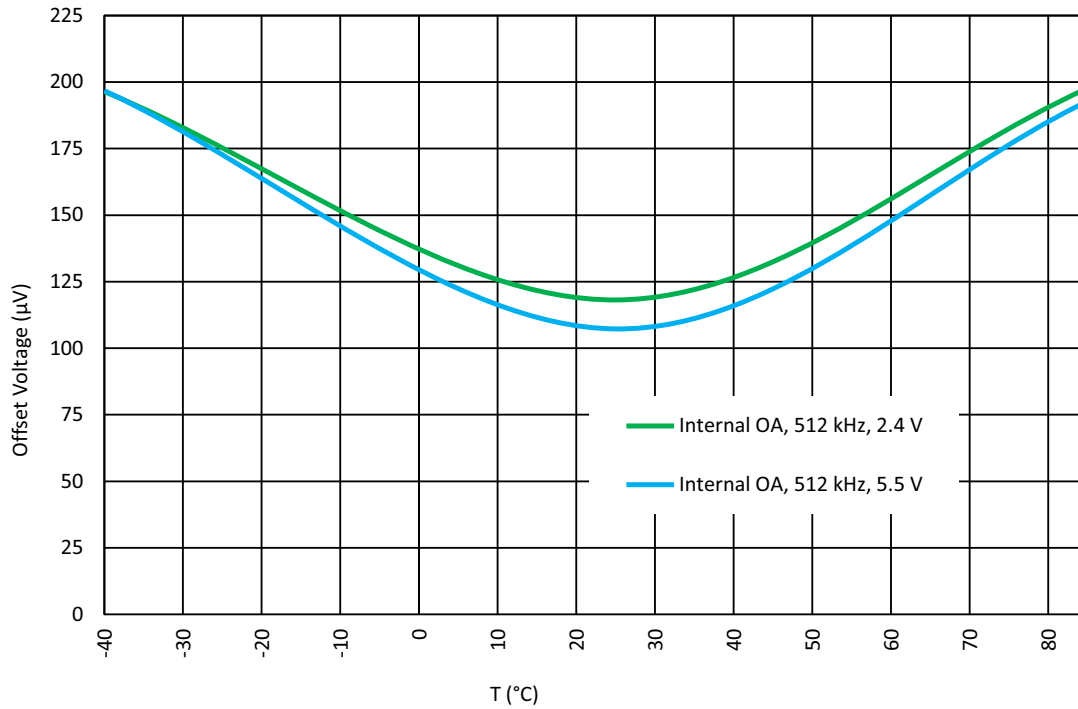

Figure 78: Internal Op Amp A_{at} at Input CM Voltage = $V_{DD}/2$, BW = 512 kHz

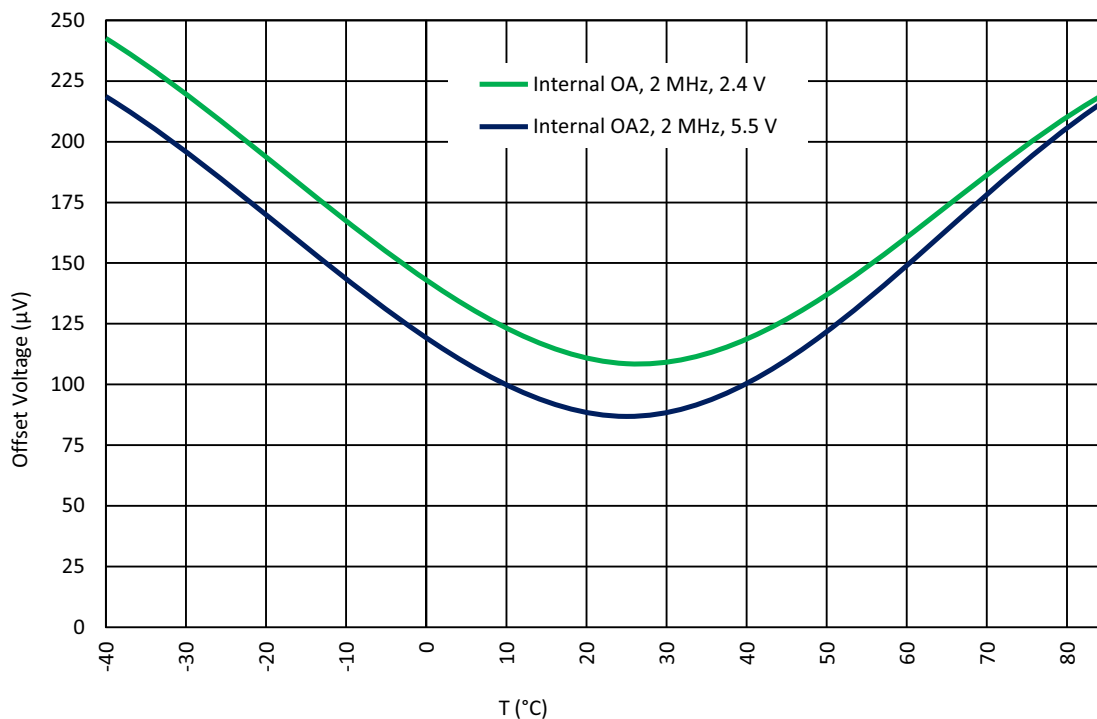

Figure 79: Internal Op Amp A_{at} at Input CM Voltage = $V_{DD}/2$, BW = 2 MHz

SLG47004

GreenPAK Programmable Mixed-Signal Matrix
with In-System Programmability and Advanced Analog Features

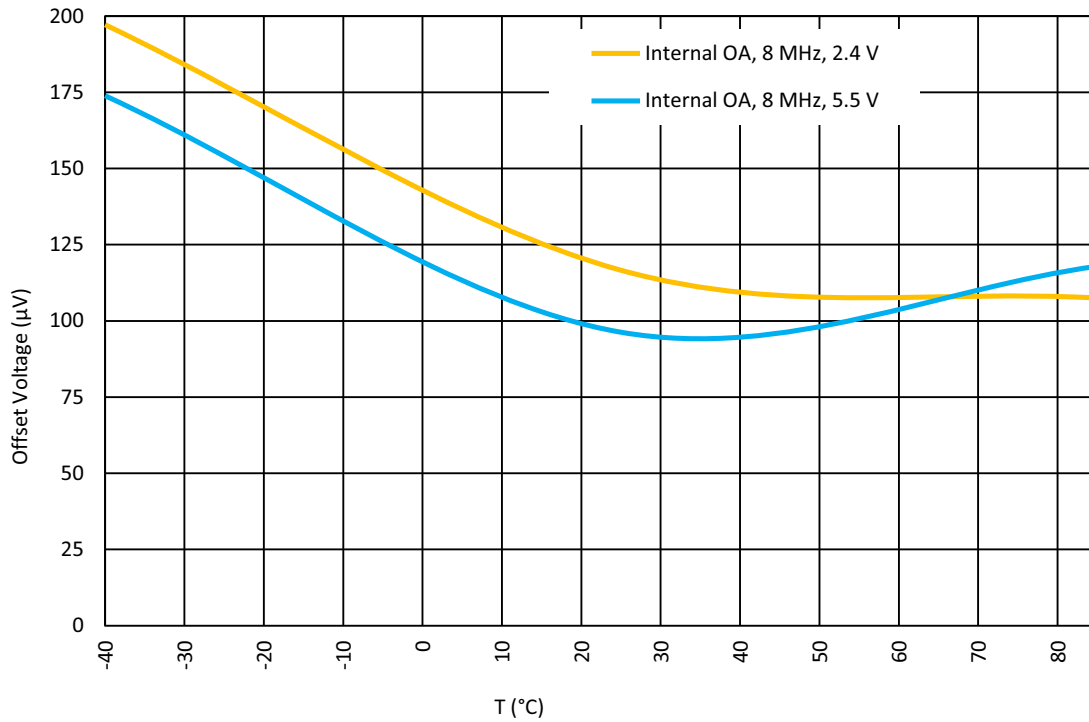

Figure 80: Internal Op Amp Input Offset Voltage vs. T_A at Input CM Voltage = $V_{DD}/2$, BW = 8 MHz

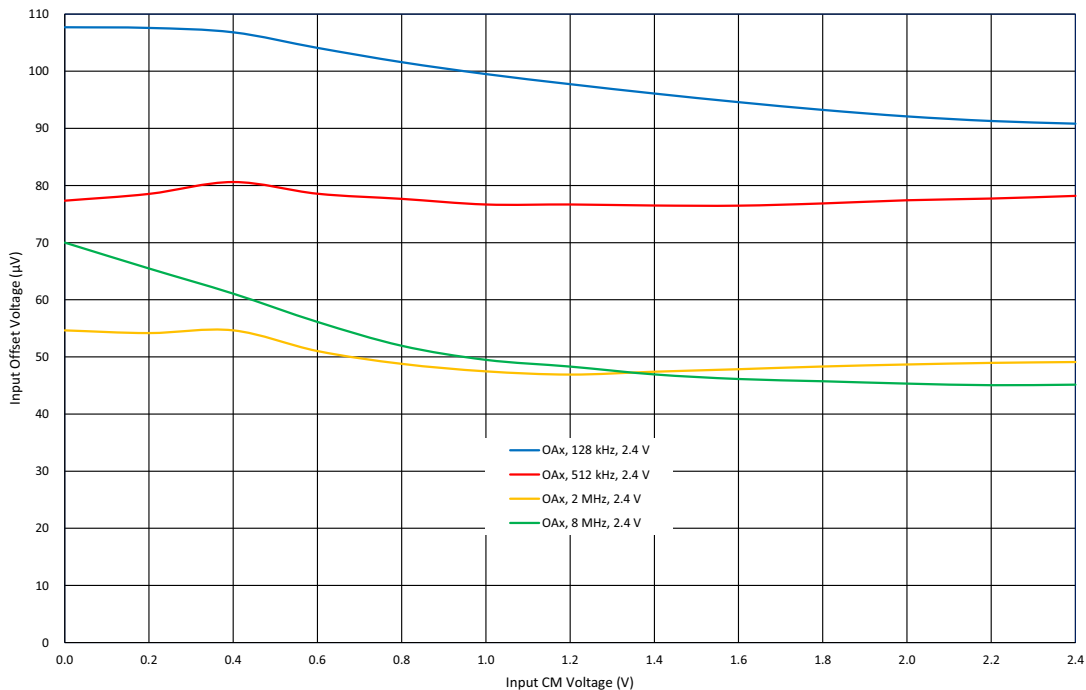

Figure 81: OpAmp0, 1 Input Offset Voltage vs. Input CM Voltage at $T = 25\text{ }^\circ\text{C}$, $V_{DDA} = 2.4\text{ V}$

SLG47004

GreenPAK Programmable Mixed-Signal Matrix
with In-System Programmability and Advanced Analog Features

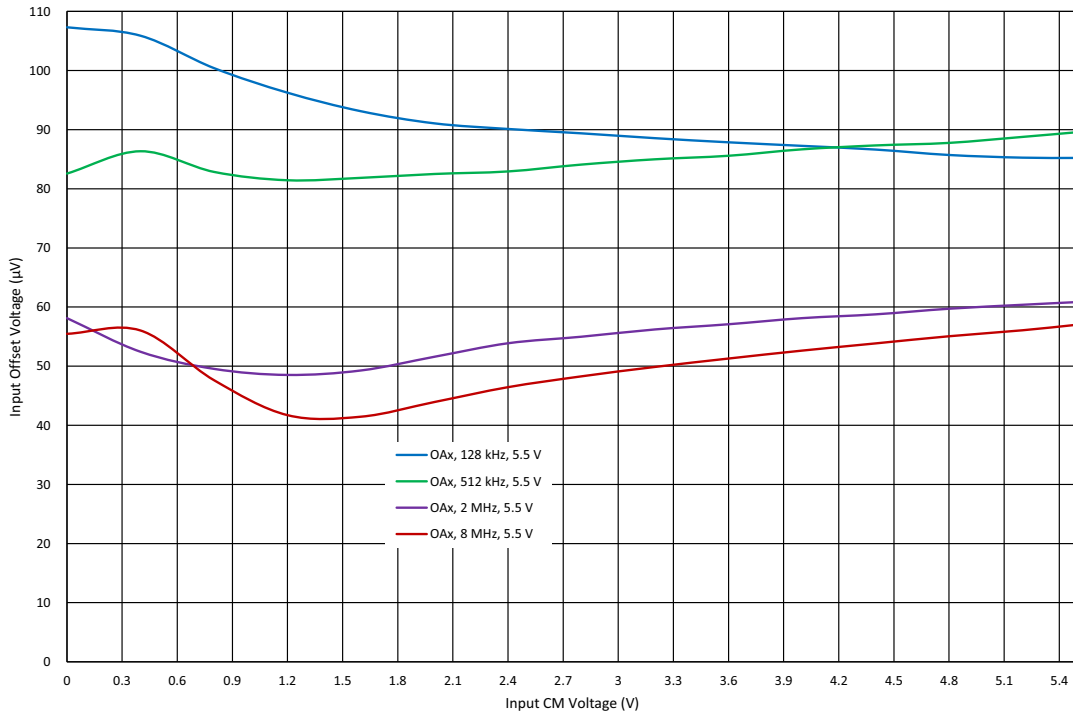

Figure 82: OpAmp0, 1 Input Offset Voltage vs. Input CM Voltage at T = 25 °C, V_{DDA} = 5.5 V

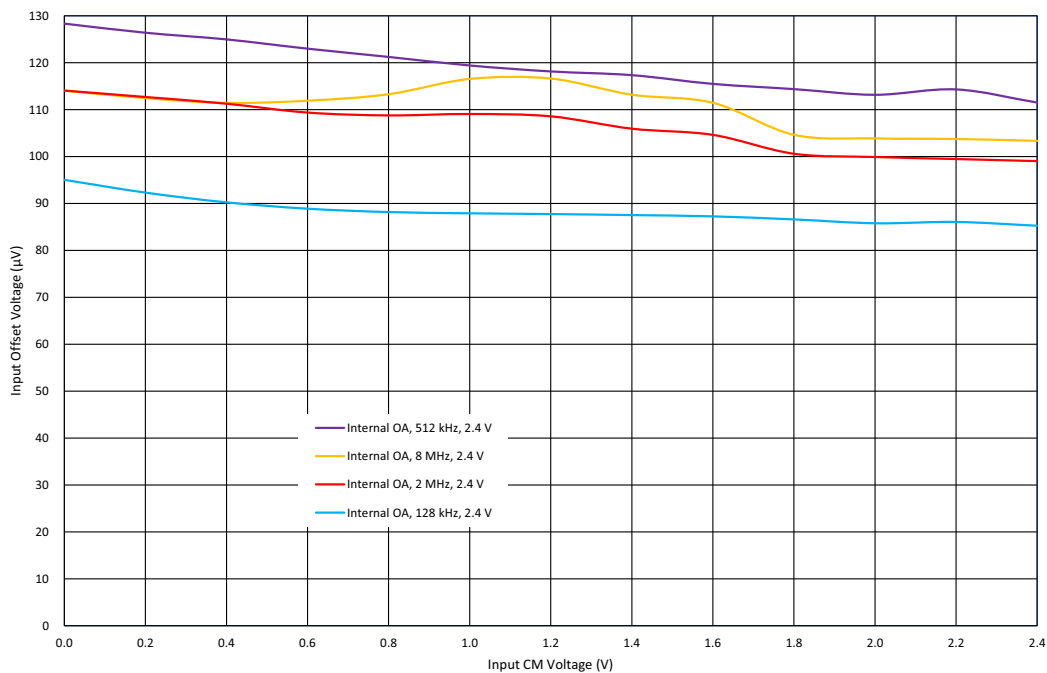

Figure 83: Internal OpAmp Input Offset Voltage vs. Input CM Voltage at T = 25 °C, V_{DDA} = 2.4 V

SLG47004

GreenPAK Programmable Mixed-Signal Matrix
with In-System Programmability and Advanced Analog Features

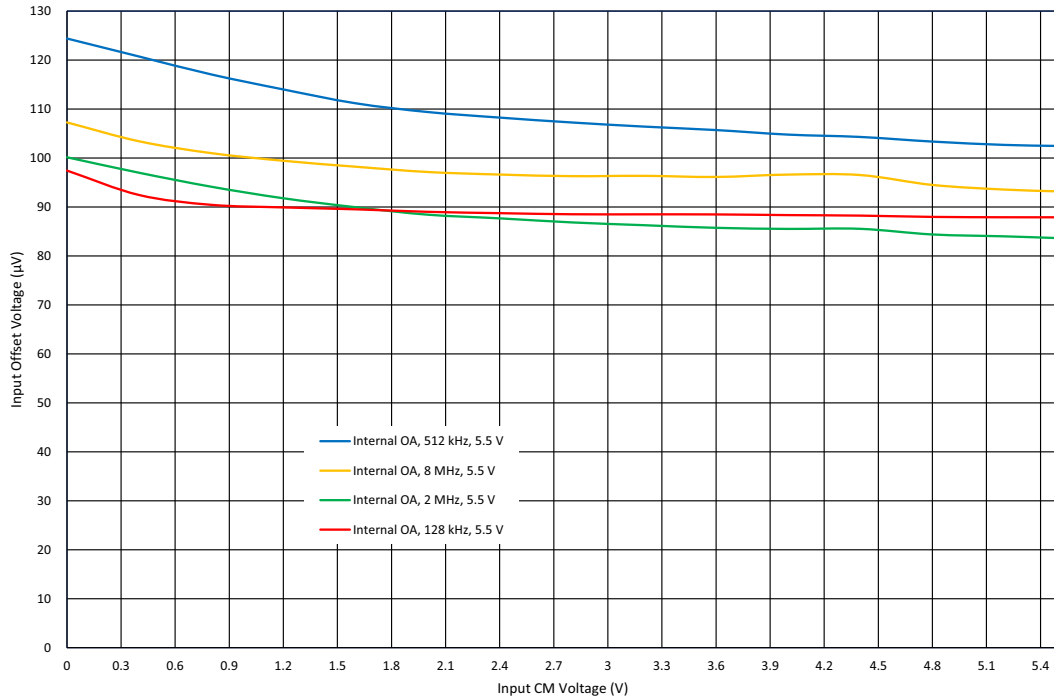

Figure 84: Internal OpAmp Input Offset Voltage vs. Input CM Voltage at T = 25 °C, V_{DDA} = 5.5 V

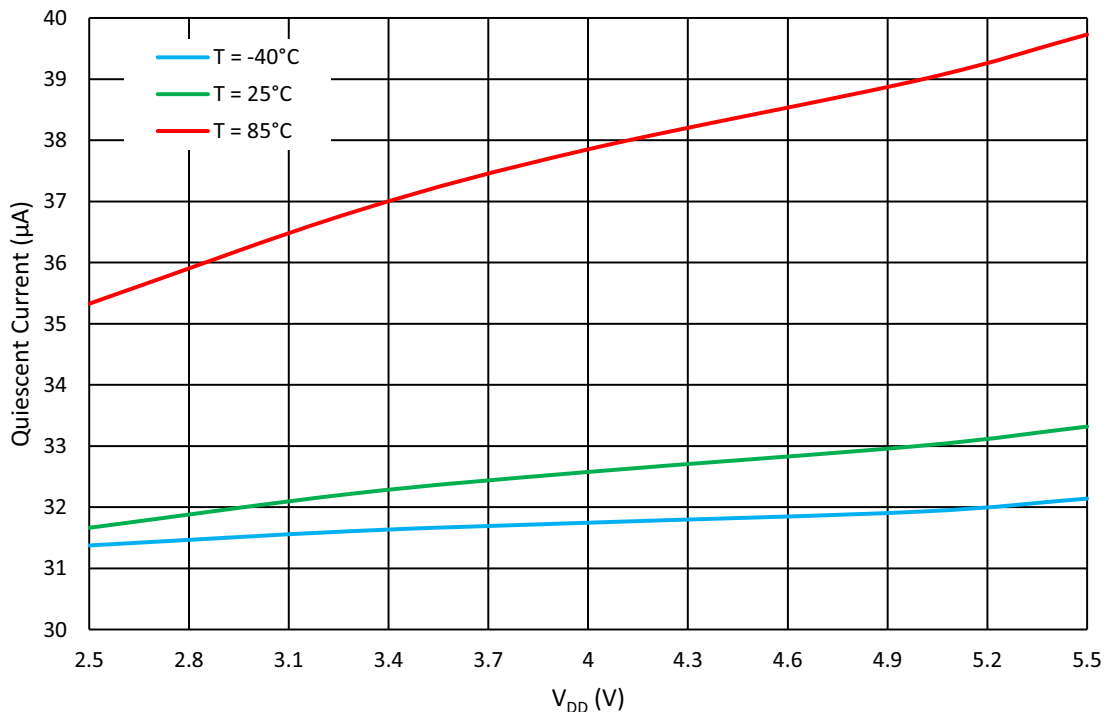

Figure 85: Quiescent Current vs. Power Supply Voltage for BW = 128 kHz

SLG47004

GreenPAK Programmable Mixed-Signal Matrix
with In-System Programmability and Advanced Analog Features

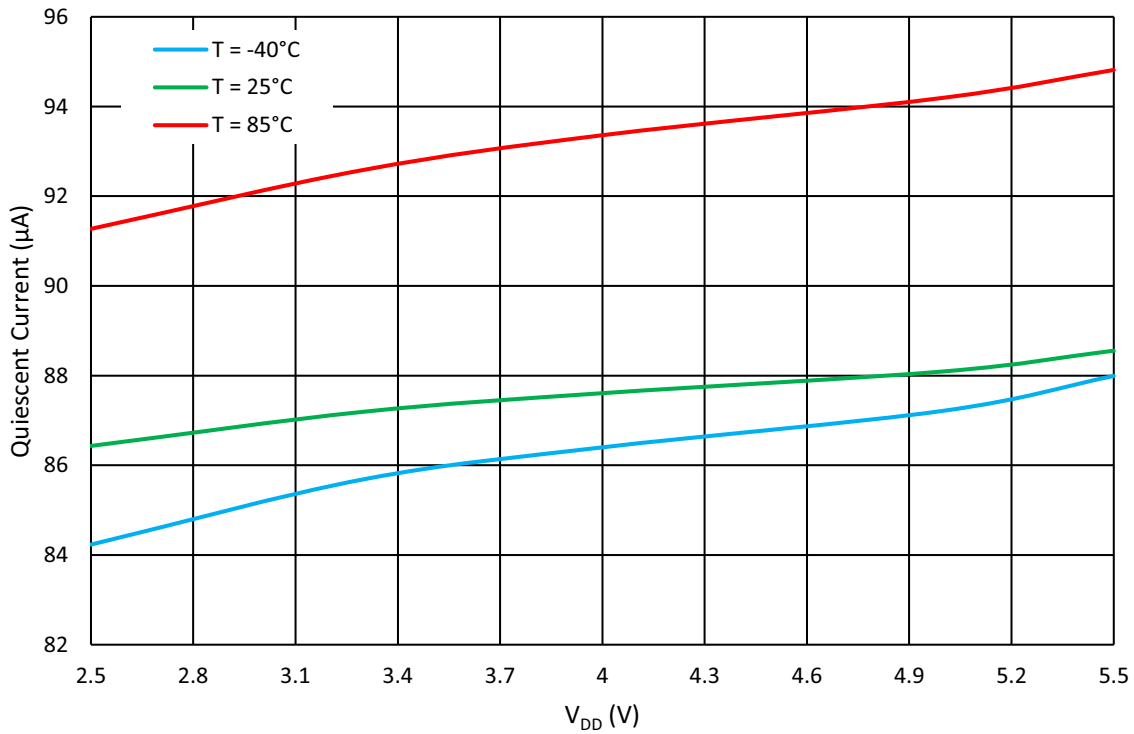

Figure 86: Quiescent Current vs. Power Supply Voltage for BW = 512 kHz

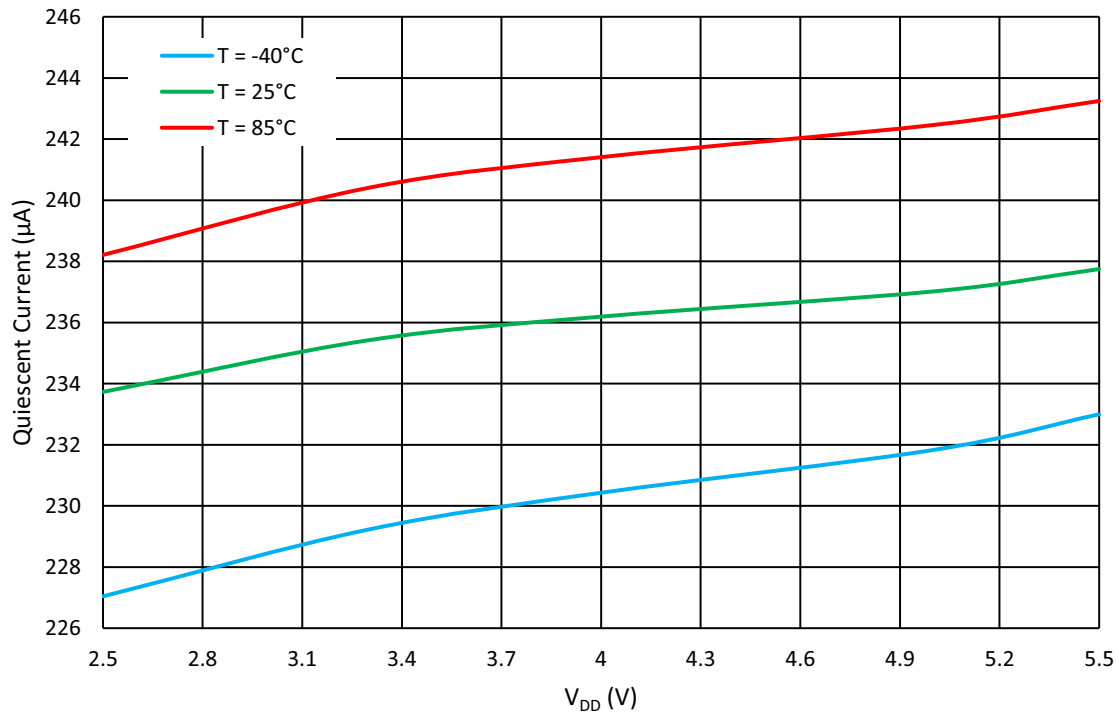

Figure 87: Quiescent Current vs. Power Supply Voltage for BW = 2 MHz

SLG47004

GreenPAK Programmable Mixed-Signal Matrix
with In-System Programmability and Advanced Analog Features

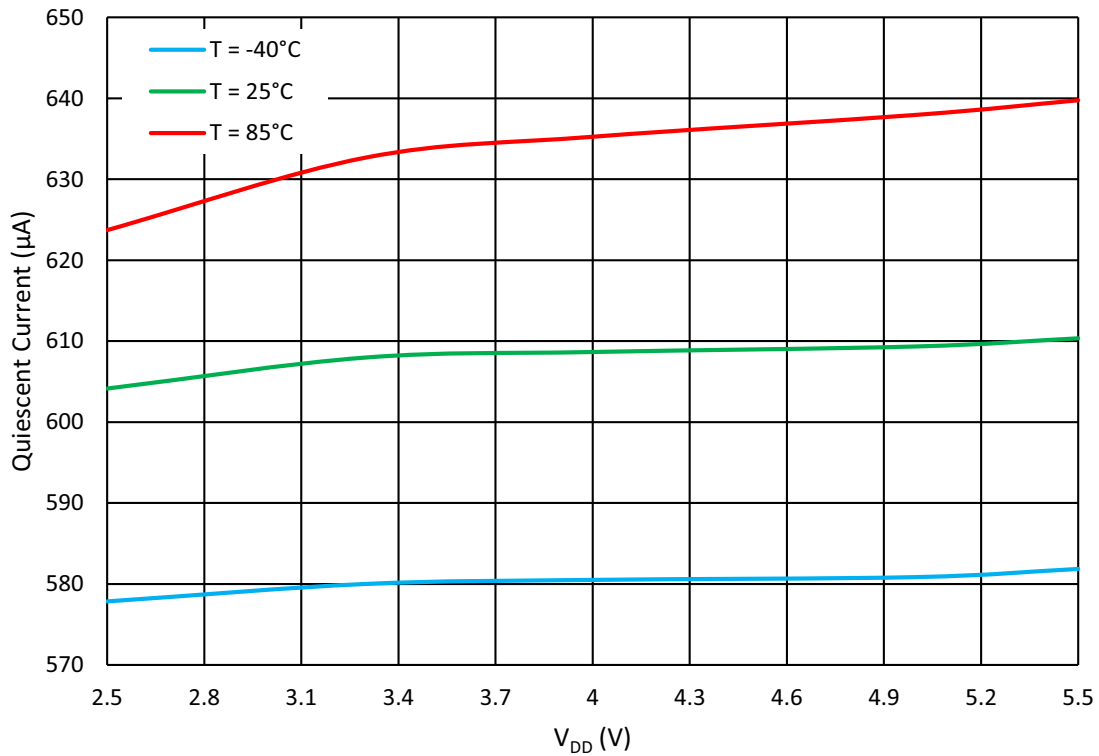

Figure 88: Quiescent Current vs. Power Supply Voltage or BW = 8 MHz

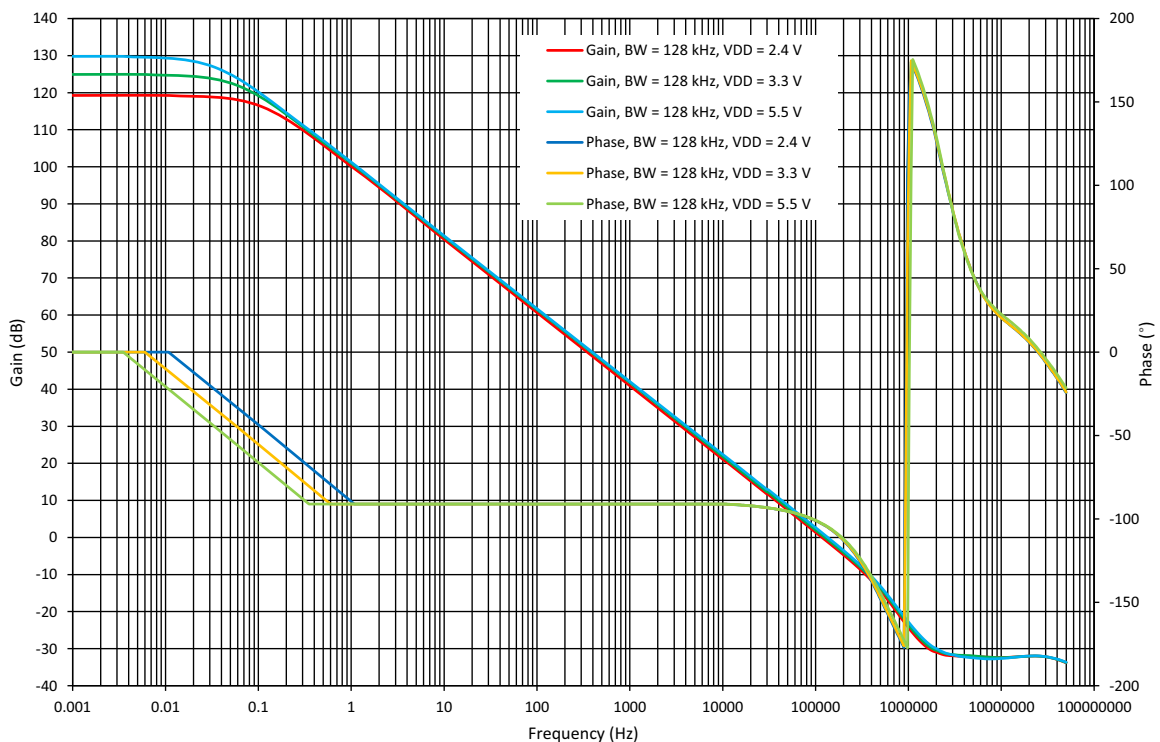

Figure 89: OA0 Open Loop Gain and Phase vs. Frequency for BW = 128 kHz

SLG47004

GreenPAK Programmable Mixed-Signal Matrix with In-System Programmability and Advanced Analog Features

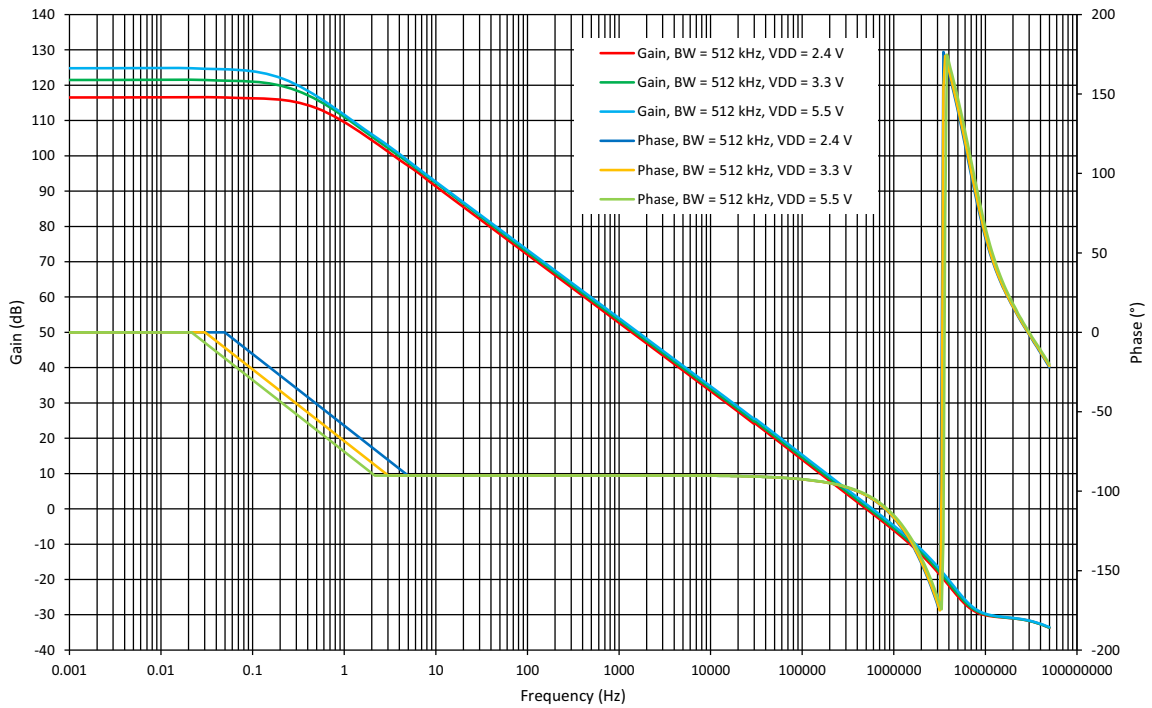

Figure 90: OA0 Open Loop Gain and Phase vs. Frequency for BW = 512 kHz

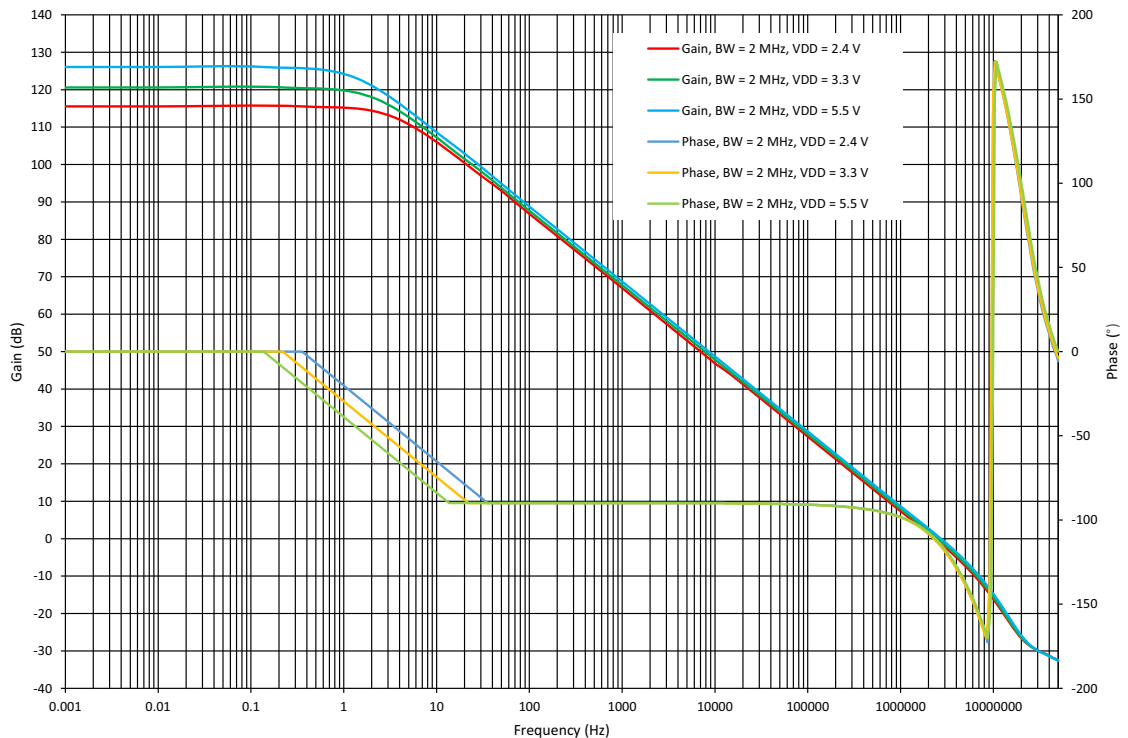

Figure 91: OA0 Open Loop Gain and Phase vs. Frequency for BW = 2 MHz

SLG47004

GreenPAK Programmable Mixed-Signal Matrix with In-System Programmability and Advanced Analog Features

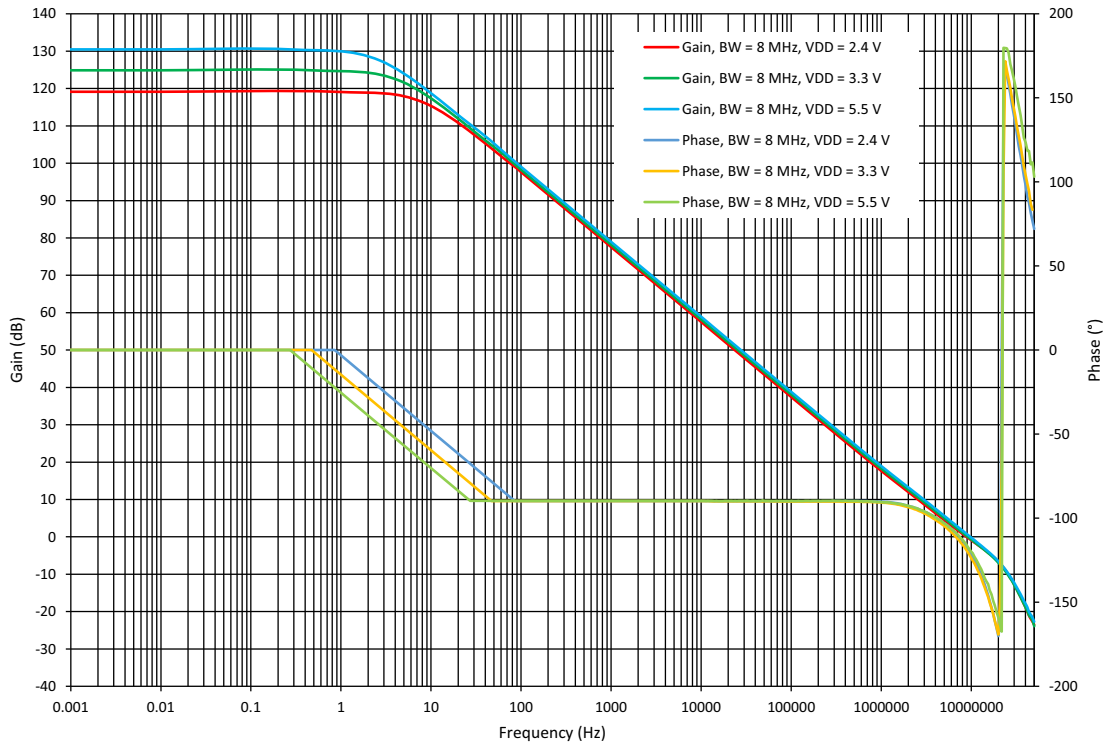

Figure 92: OA0 Open Loop Gain and Phase vs. Frequency for BW = 8 MHz

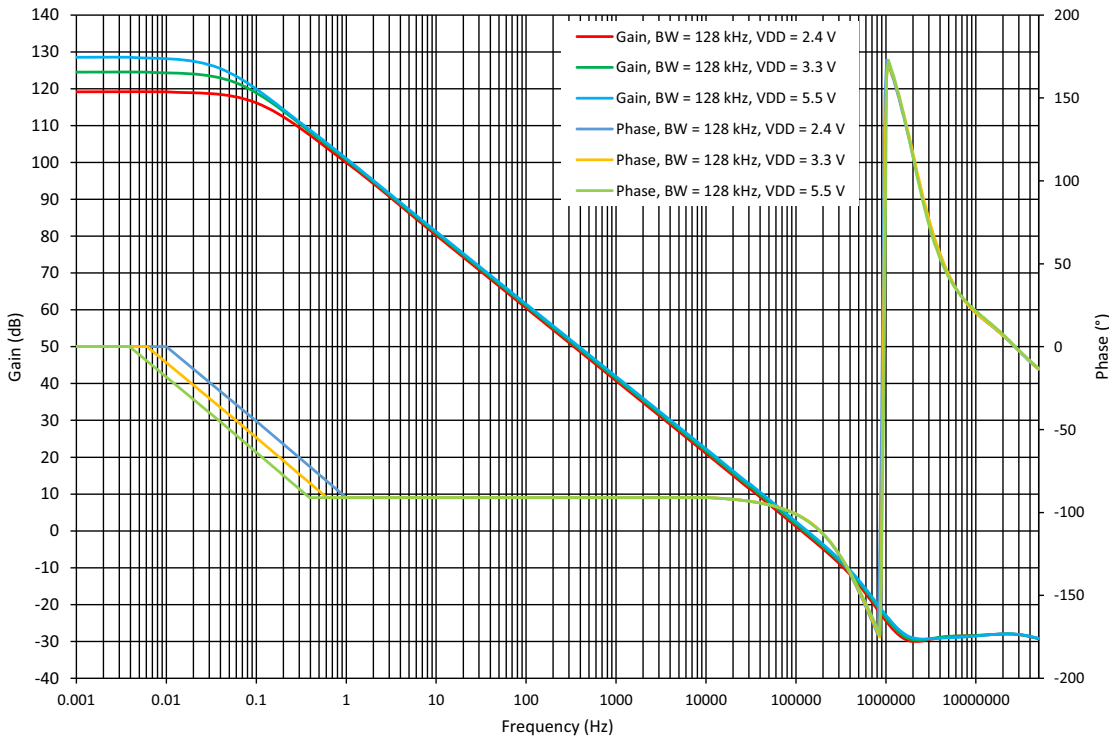

Figure 93: OA1 Open Loop Gain and Phase vs. Frequency for BW = 128 kHz

SLG47004

GreenPAK Programmable Mixed-Signal Matrix
with In-System Programmability and Advanced Analog Features

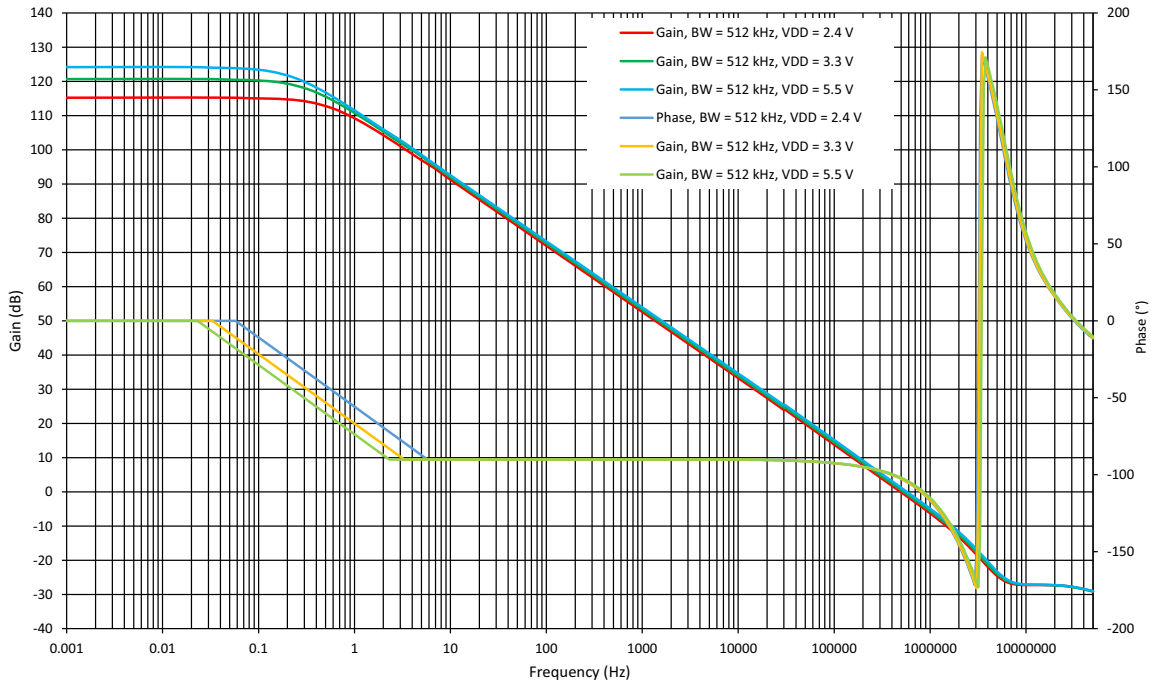

Figure 94: OA1 Open Loop Gain and Phase vs. Frequency for BW = 512 kHz

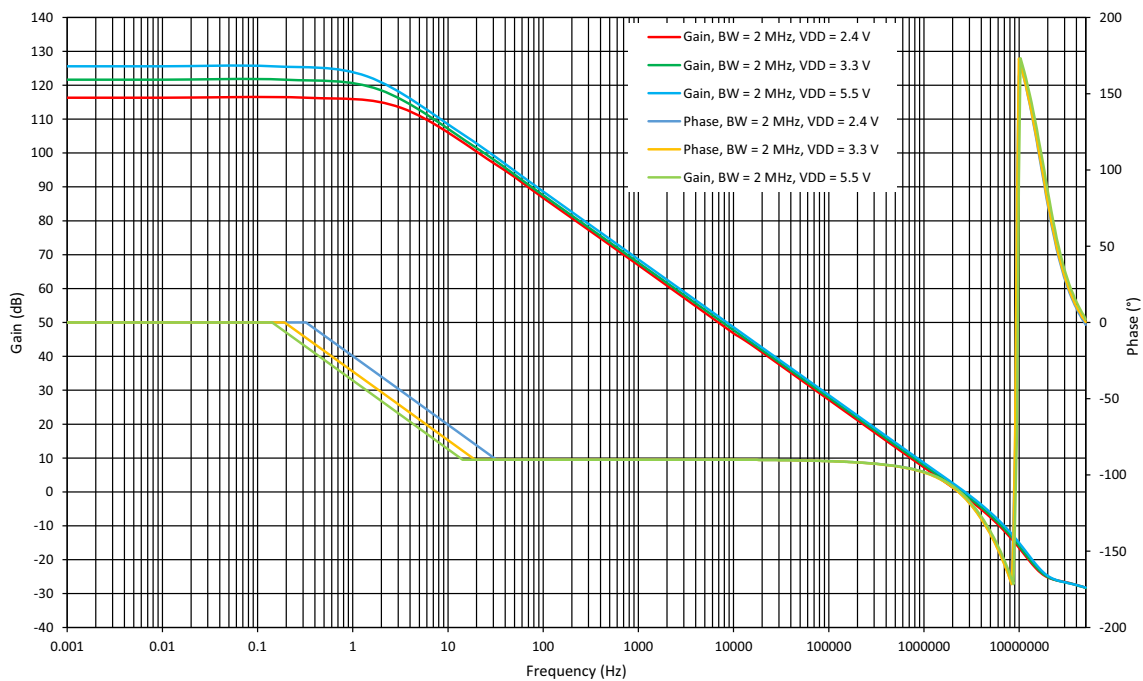

Figure 95: OA1 Open Loop Gain and Phase vs. Frequency for BW = 2 MHz

SLG47004

GreenPAK Programmable Mixed-Signal Matrix with In-System Programmability and Advanced Analog Features

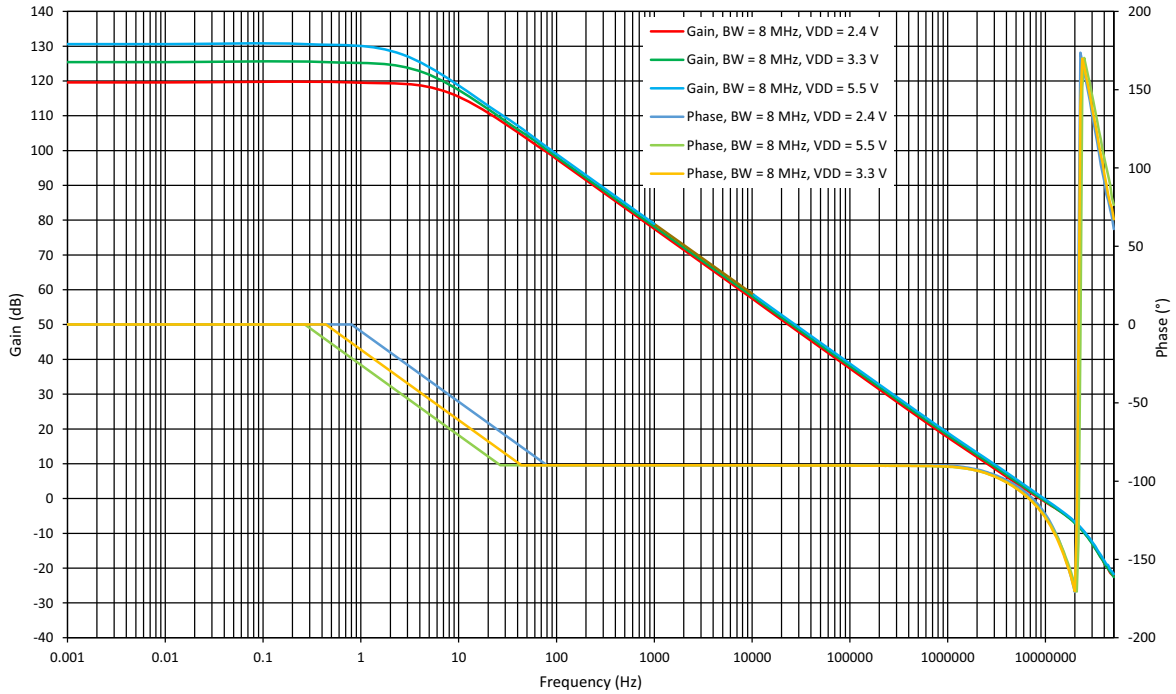

Figure 96: OA1 Open Loop Gain and Phase vs. Frequency for BW = 8 MHz

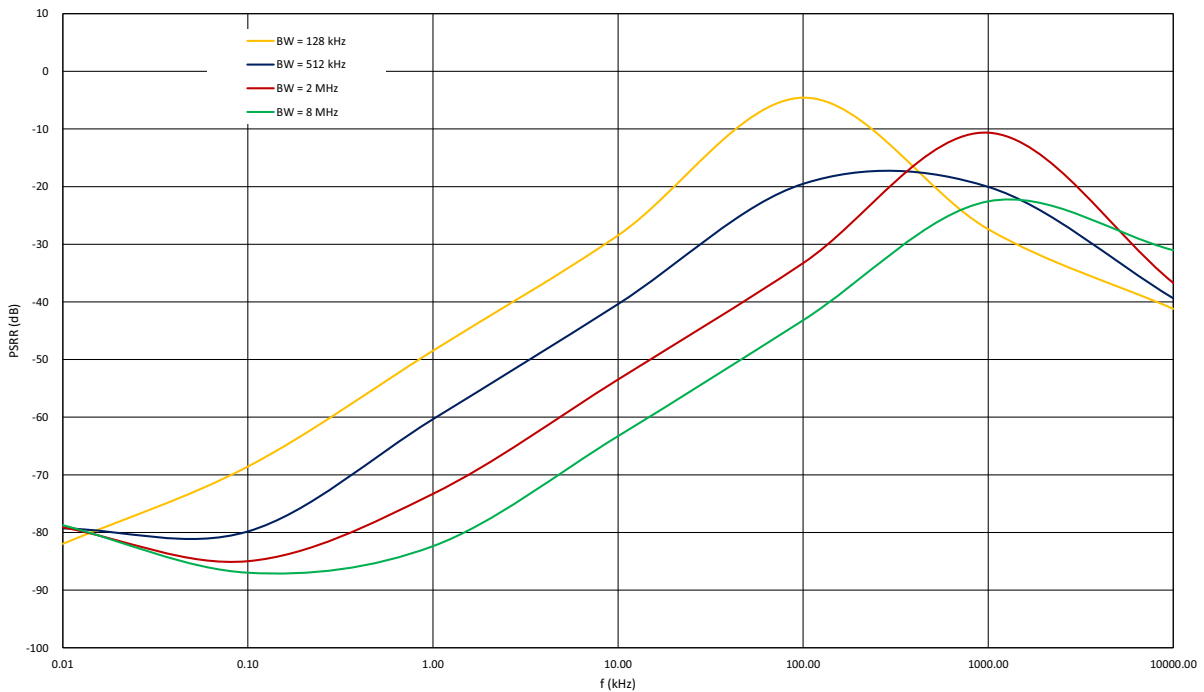

Figure 97: PSRR vs. Frequency $V_{DD} = 2.4\text{ V to }5.5\text{ V}$

SLG47004

GreenPAK Programmable Mixed-Signal Matrix
with In-System Programmability and Advanced Analog Features

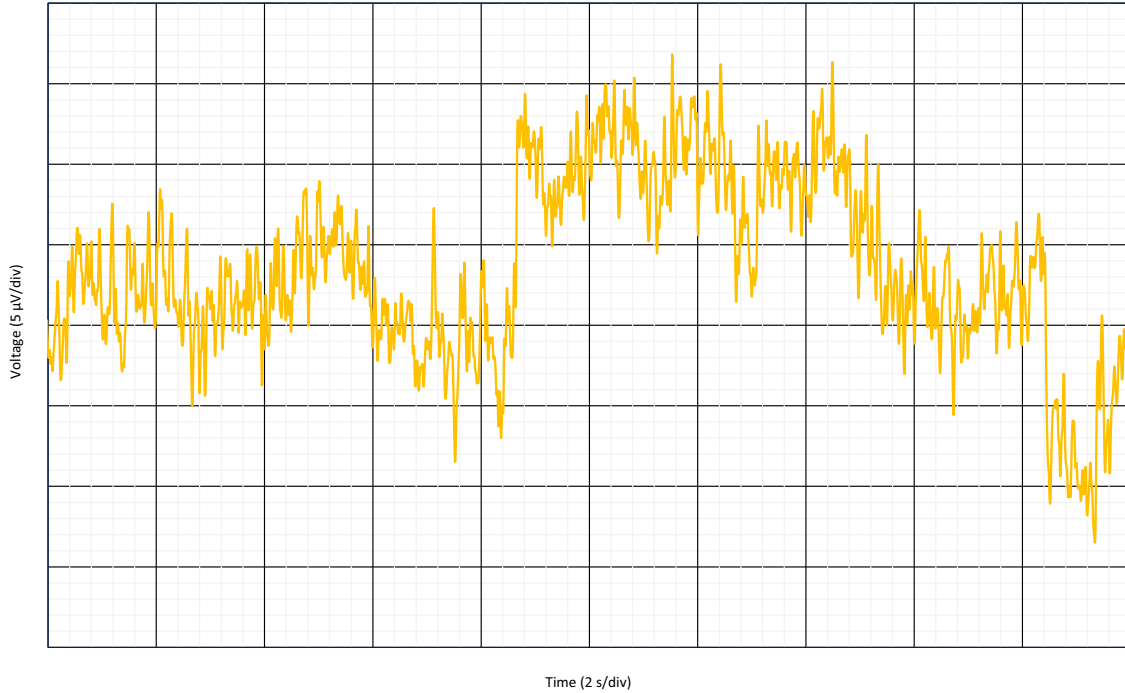

Figure 98: 0.1 Hz to 10 Hz Noise, BW = 128 kHz

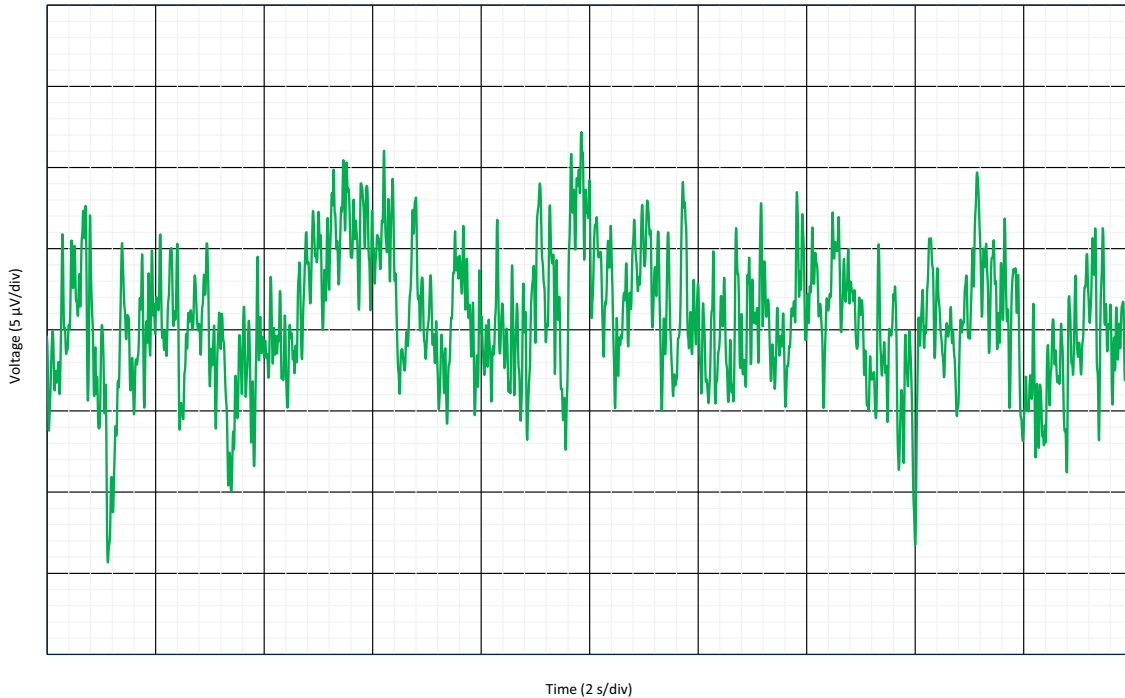

Figure 99: 0.1 Hz to 10 Hz Noise, BW = 512 kHz

SLG47004

GreenPAK Programmable Mixed-Signal Matrix
with In-System Programmability and Advanced Analog Features

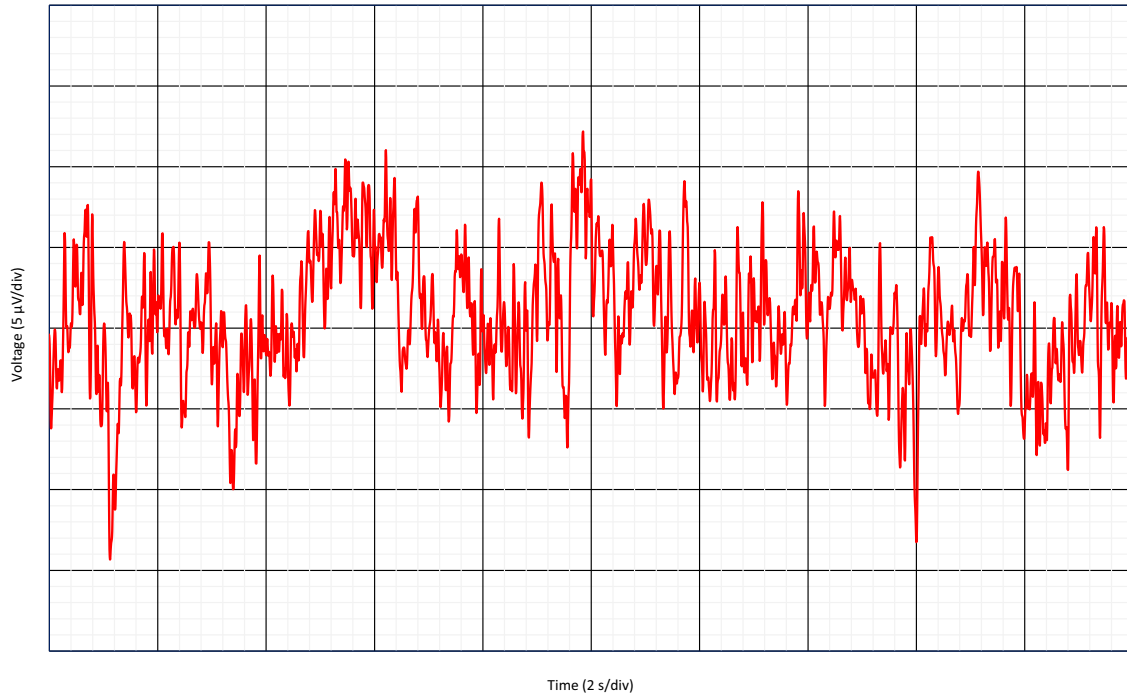

Figure 100: 0.1 Hz to 10 Hz Noise, BW = 2 MHz

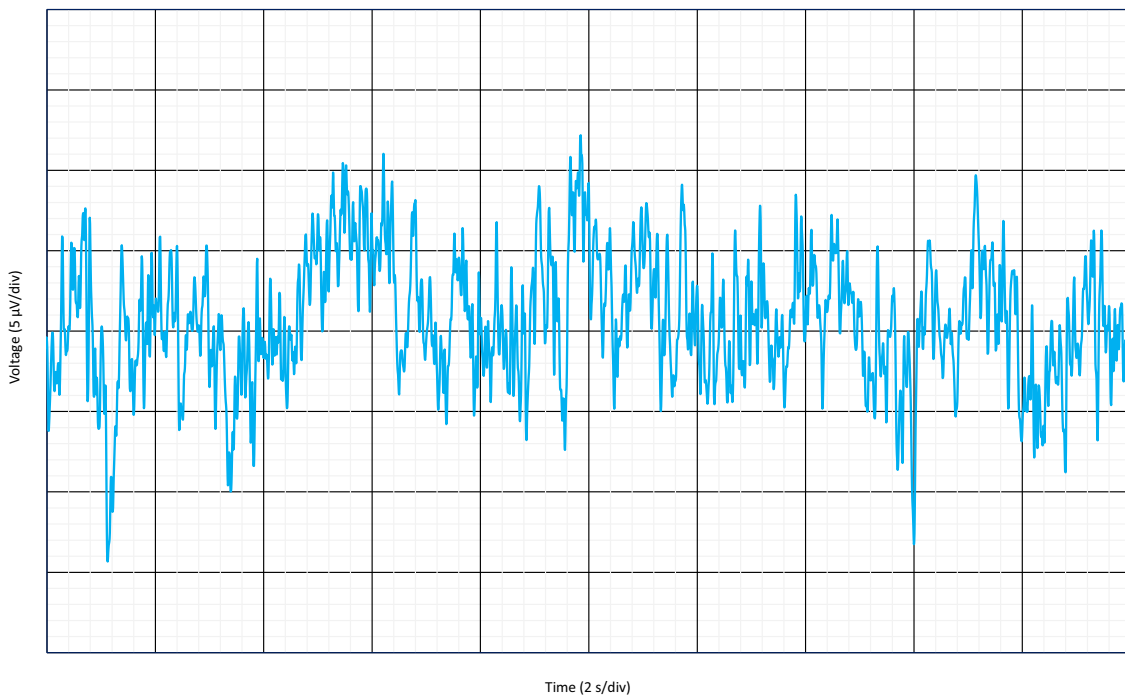

Figure 101: 0.1 Hz to 10 Hz Noise, BW = 8 MHz

SLG47004

GreenPAK Programmable Mixed-Signal Matrix
with In-System Programmability and Advanced Analog Features

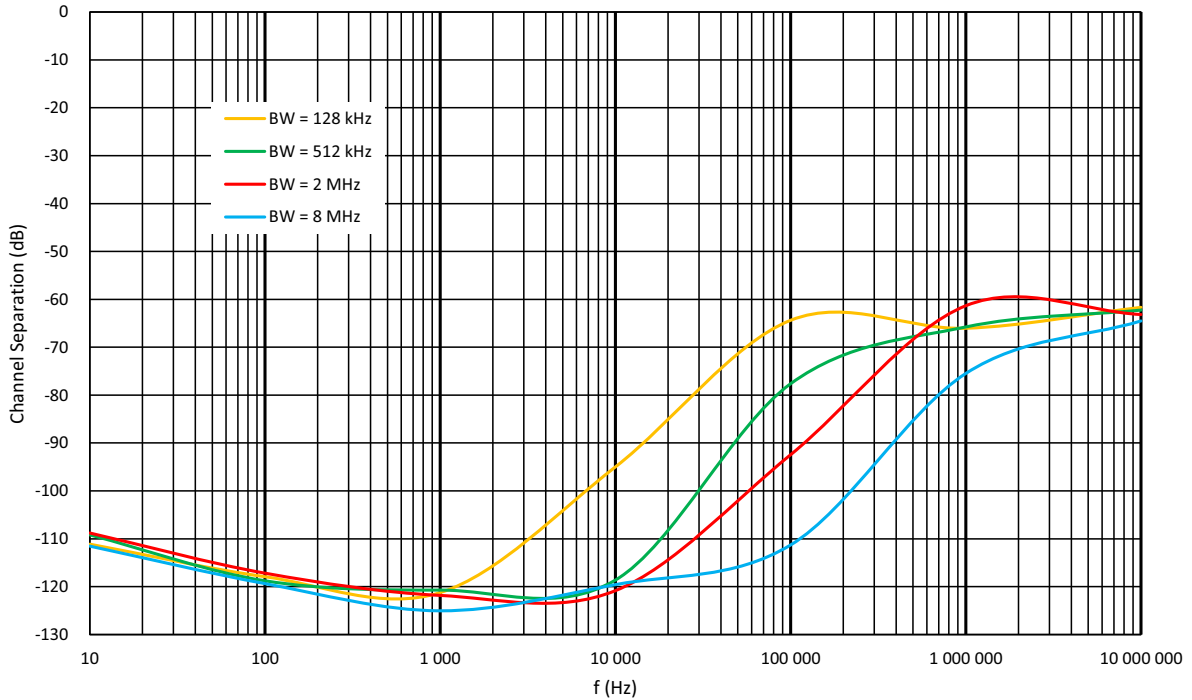

Figure 102: Channel Separation vs. Frequency

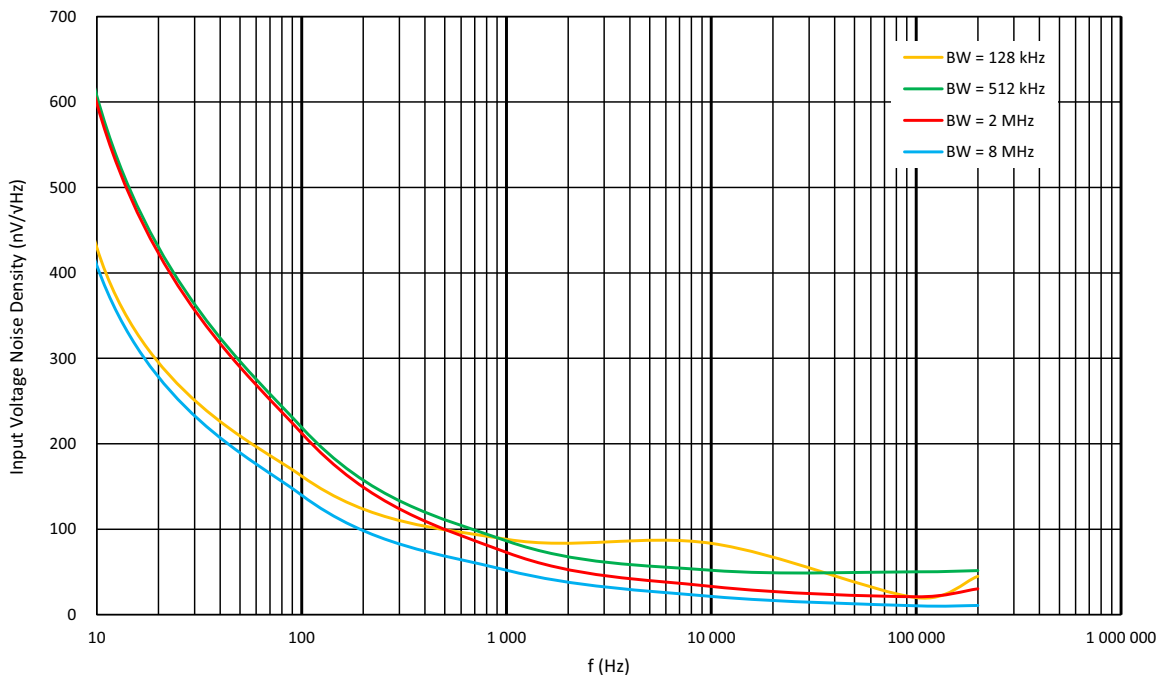

Figure 103: Op Ampx Noise Voltage Density vs. Frequency

SLG47004

GreenPAK Programmable Mixed-Signal Matrix
with In-System Programmability and Advanced Analog Features

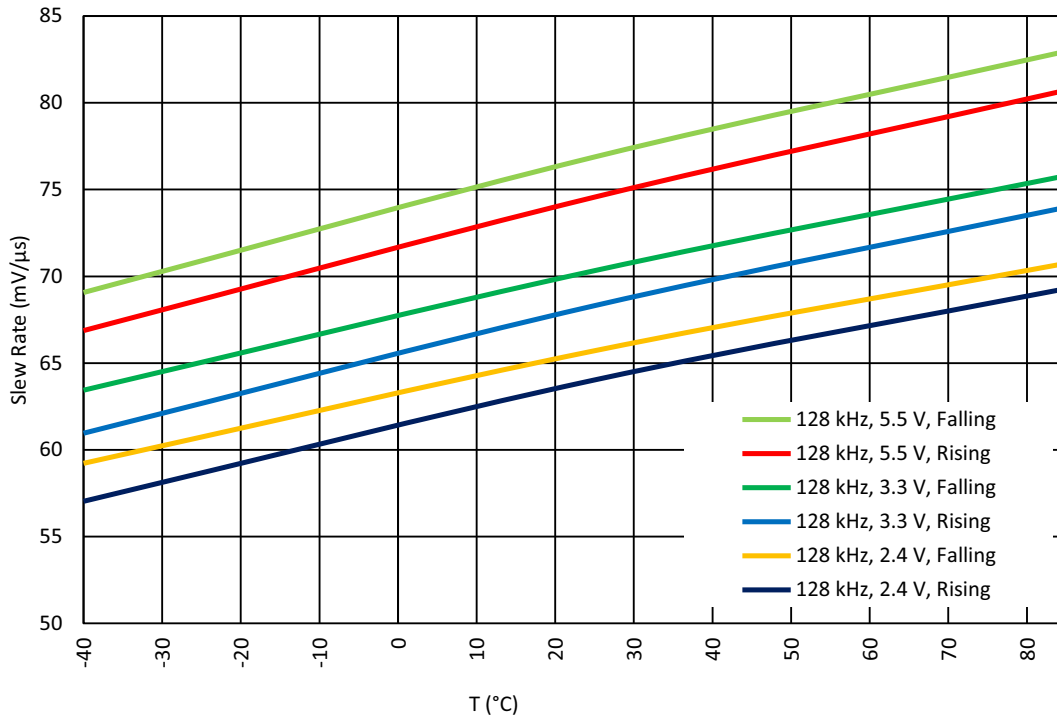

Figure 104: Slew Rate vs. Ambient Temperature $G = 1 \text{ V/V}$; $R_L = 50 \text{ k}\Omega$ for $BW = 128 \text{ kHz}$

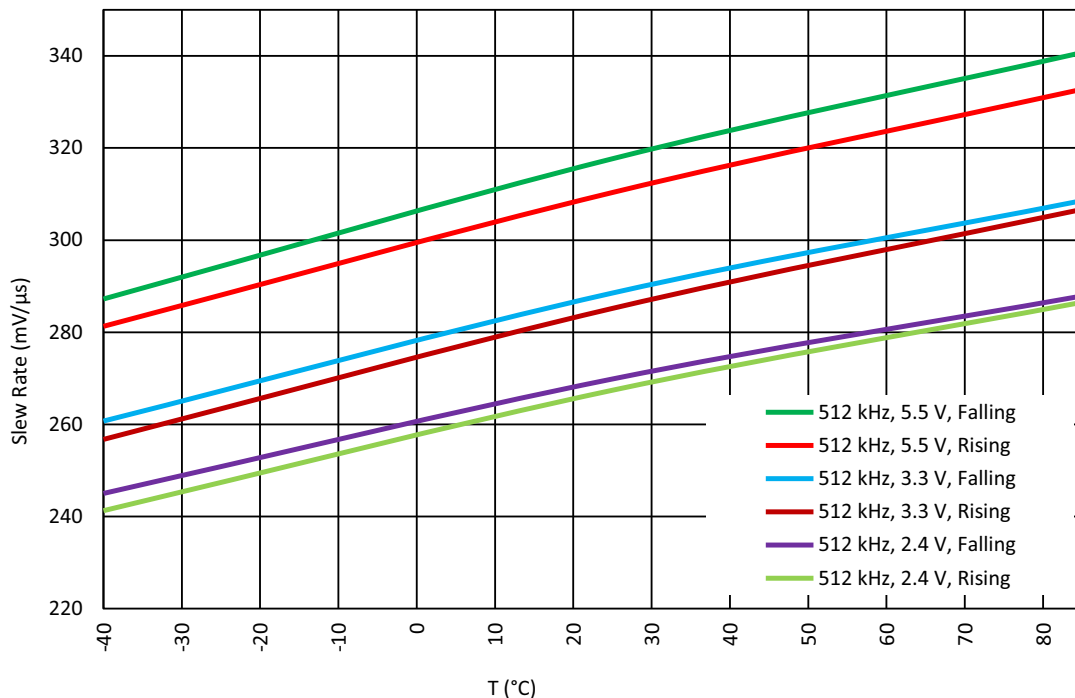

Figure 105: Slew Rate vs. Ambient Temperature $G = 1 \text{ V/V}$; $R_L = 50 \text{ k}\Omega$ for $BW = 512 \text{ kHz}$

SLG47004

GreenPAK Programmable Mixed-Signal Matrix
with In-System Programmability and Advanced Analog Features

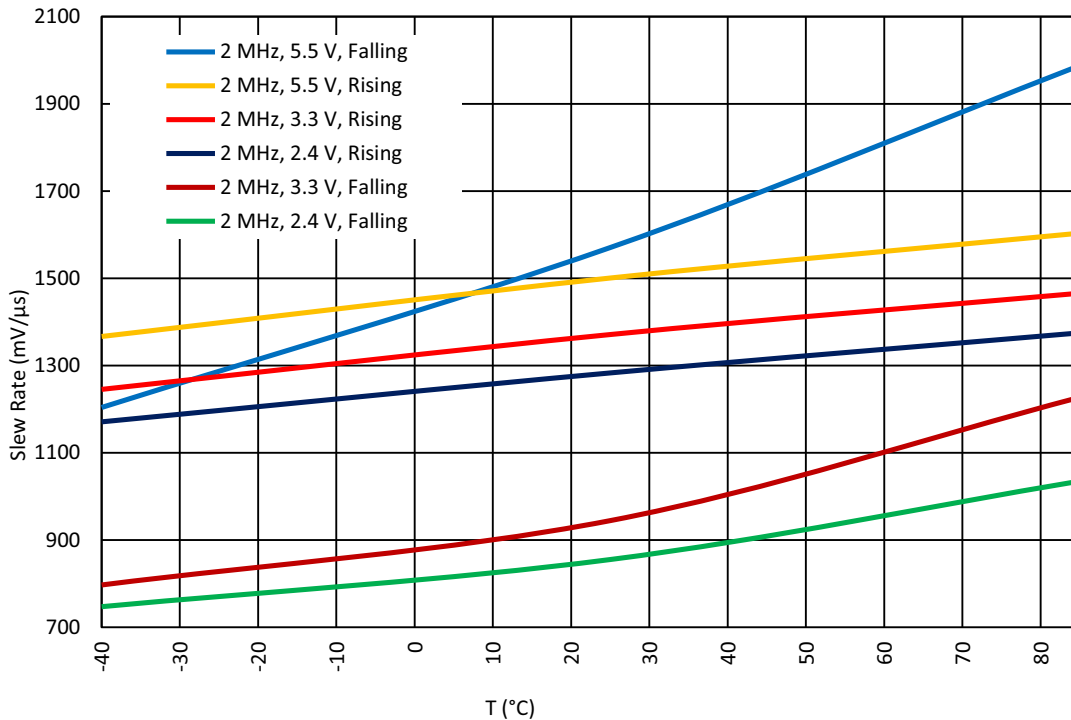

Figure 106: Slew Rate vs. Ambient Temperature $G = 1\text{ V/V}$; $R_L = 50\text{ k}\Omega$ for $BW = 2\text{ MHz}$

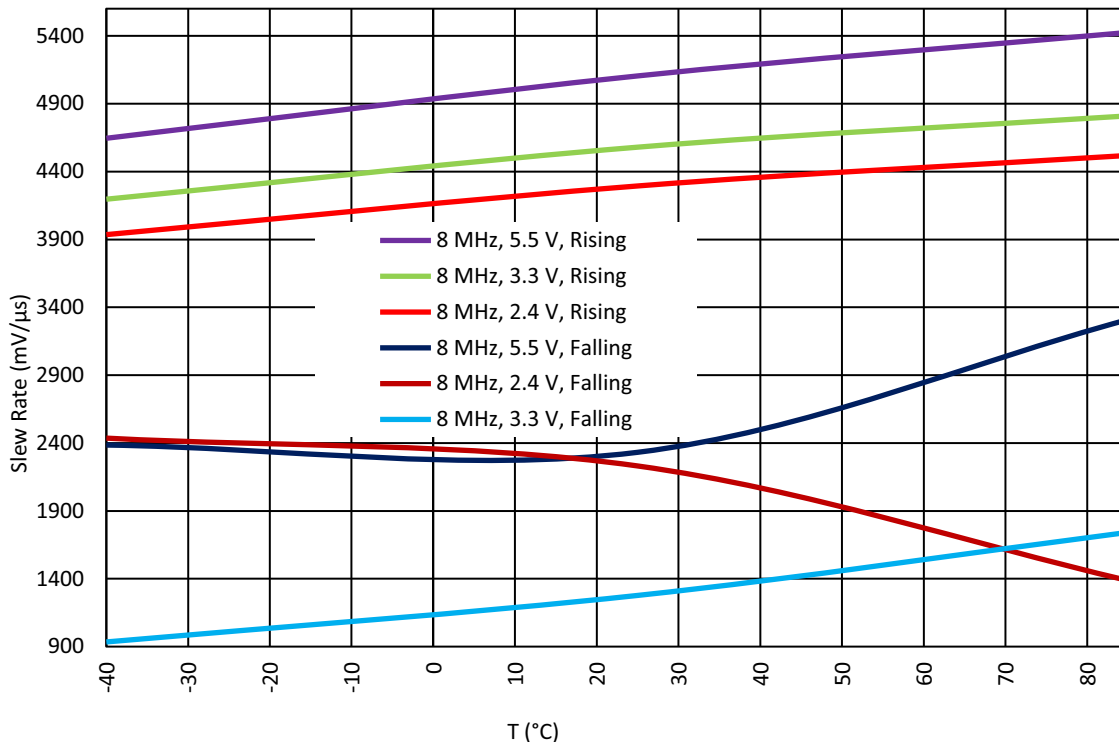

Figure 107: Slew Rate vs. Ambient Temperature $G = 1\text{ V/V}$; $R_L = 50\text{ k}\Omega$ for $BW = 8\text{ MHz}$

SLG47004

GreenPAK Programmable Mixed-Signal Matrix
with In-System Programmability and Advanced Analog Features

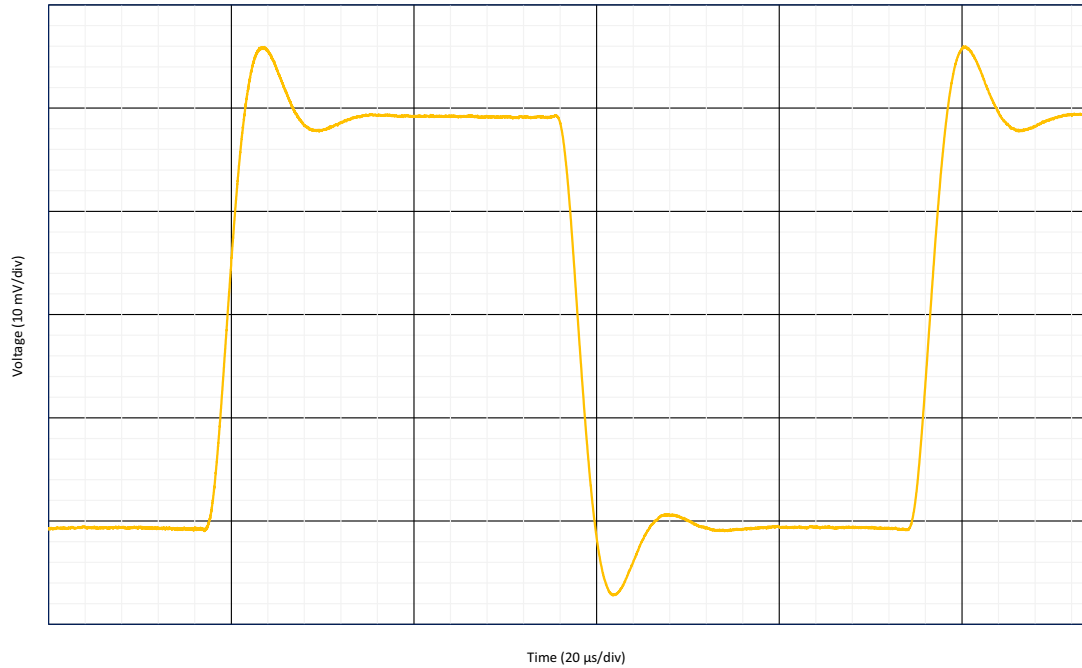

Figure 108: Small Signal Inverting Step Response $G = -1$ V/V, $R_L = 50$ k Ω , $C_L = 60$ pF, BW = 128 kHz

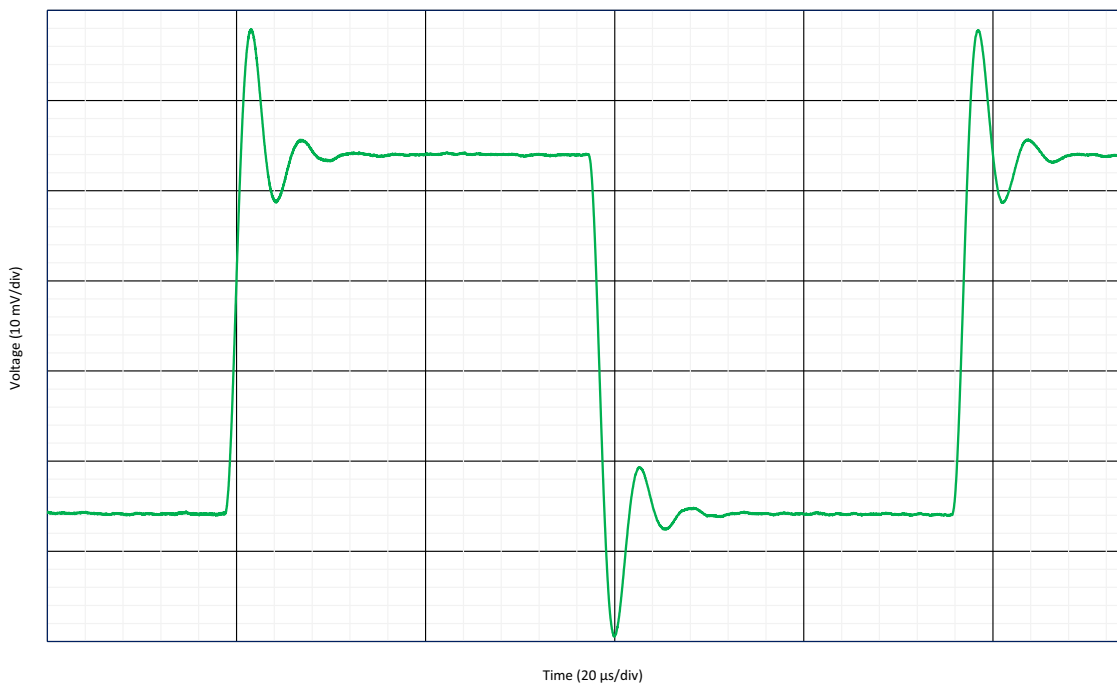

Figure 109: Small Signal Inverting Step Response $G = -1$ V/V, $R_L = 50$ k Ω , $C_L = 60$ pF, BW = 512 kHz

SLG47004

GreenPAK Programmable Mixed-Signal Matrix
with In-System Programmability and Advanced Analog Features

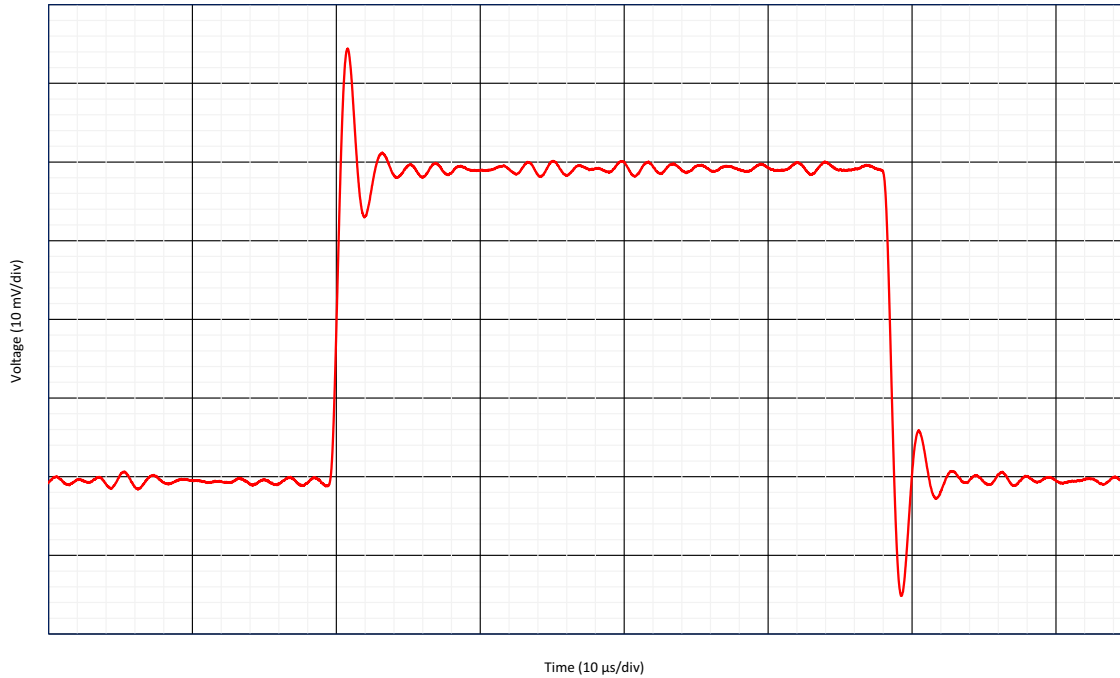

Figure 110: Small Signal Inverting Step Response $G = -1$ V/V, $R_L = 50$ k Ω , $C_L = 60$ pF, BW = 2 MHz

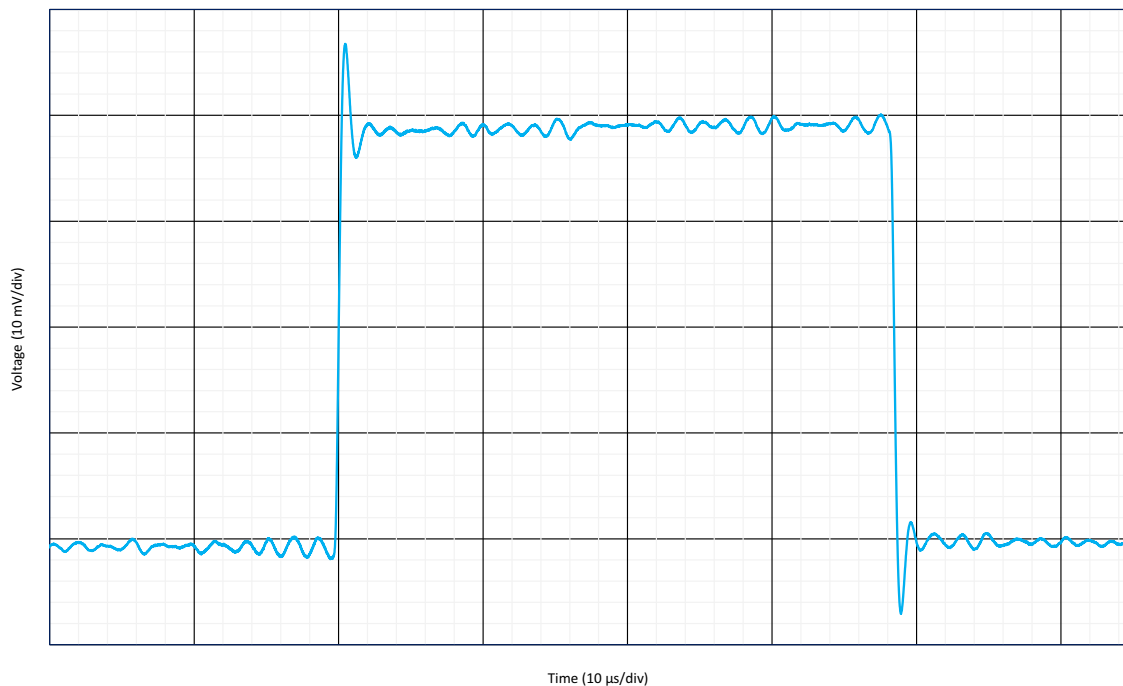

Figure 111: Small Signal Inverting Step Response $G = -1$ V/V, $R_L = 50$ k Ω , $C_L = 60$ pF, BW = 8 MHz

SLG47004

GreenPAK Programmable Mixed-Signal Matrix
with In-System Programmability and Advanced Analog Features

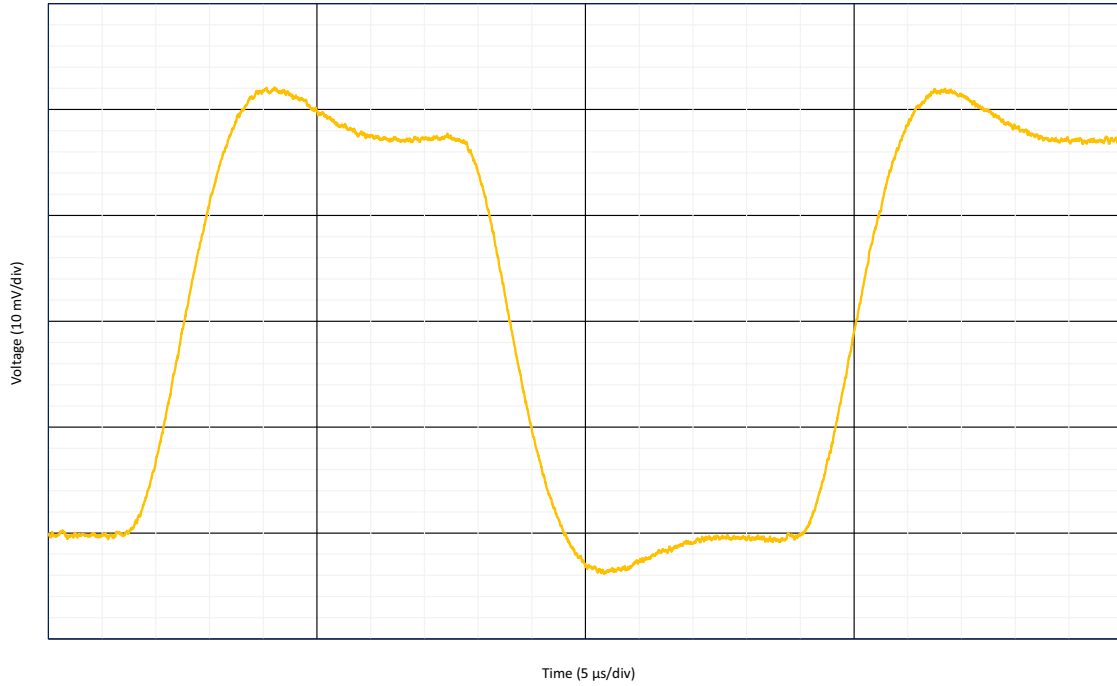

Figure 112: Small Signal Non-Inverting Step Response $G = -1 \text{ V/V}$, $R_L = 50 \text{ k}\Omega$, $C_L = 60 \text{ pF}$, $BW = 128 \text{ kHz}$

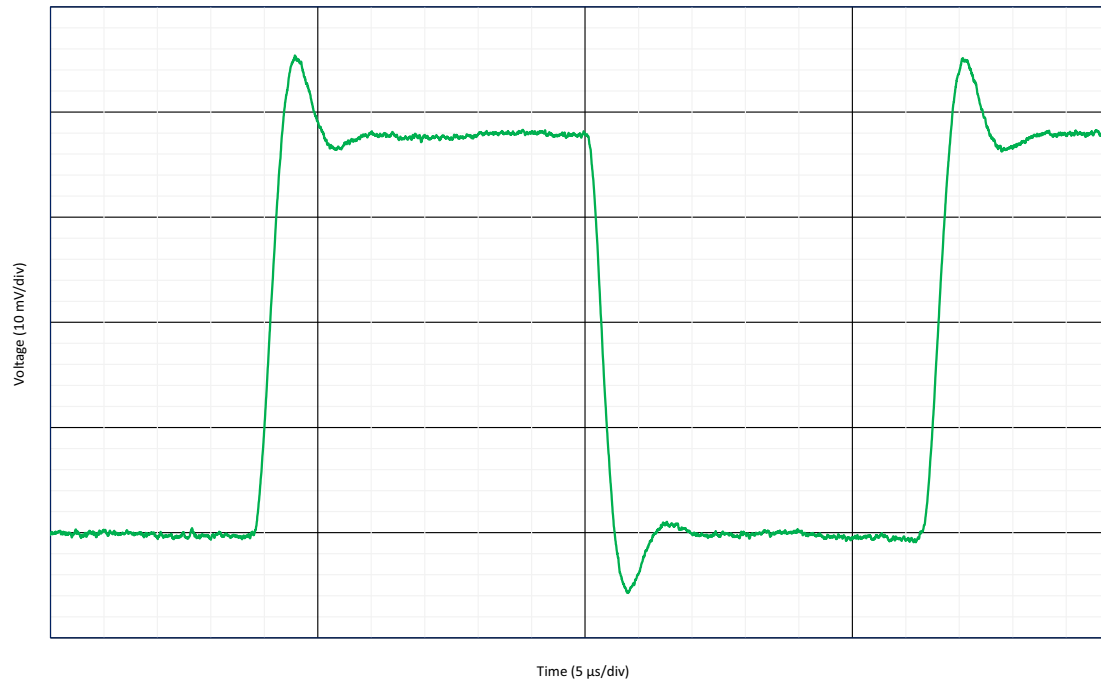

Figure 113: Small Signal Non-Inverting Step Response $G = -1 \text{ V/V}$, $R_L = 50 \text{ k}\Omega$, $C_L = 60 \text{ pF}$, $BW = 512 \text{ kHz}$

SLG47004

GreenPAK Programmable Mixed-Signal Matrix
with In-System Programmability and Advanced Analog Features



Figure 114: Small Signal Non-Inverting Step Response $G = -1 \text{ V/V}$, $R_L = 50 \text{ k}\Omega$, $C_L = 60 \text{ pF}$, $BW = 2 \text{ MHz}$

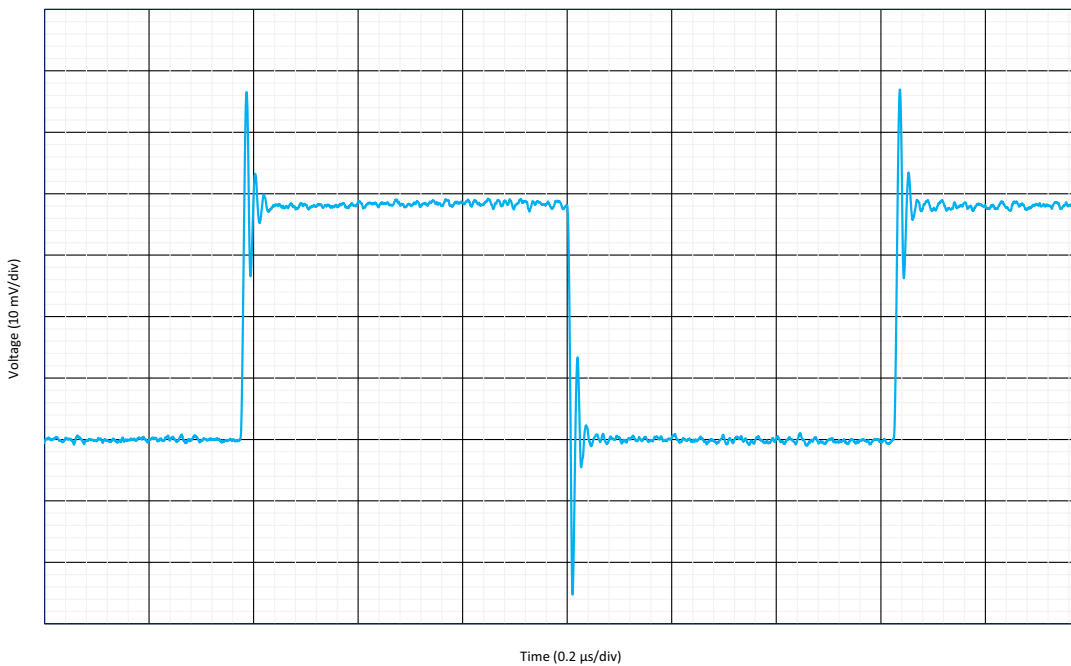

Figure 115: Small Signal Non-Inverting Step Response $G = -1 \text{ V/V}$, $R_L = 50 \text{ k}\Omega$, $C_L = 60 \text{ pF}$, $BW = 8 \text{ MHz}$

SLG47004

GreenPAK Programmable Mixed-Signal Matrix
with In-System Programmability and Advanced Analog Features

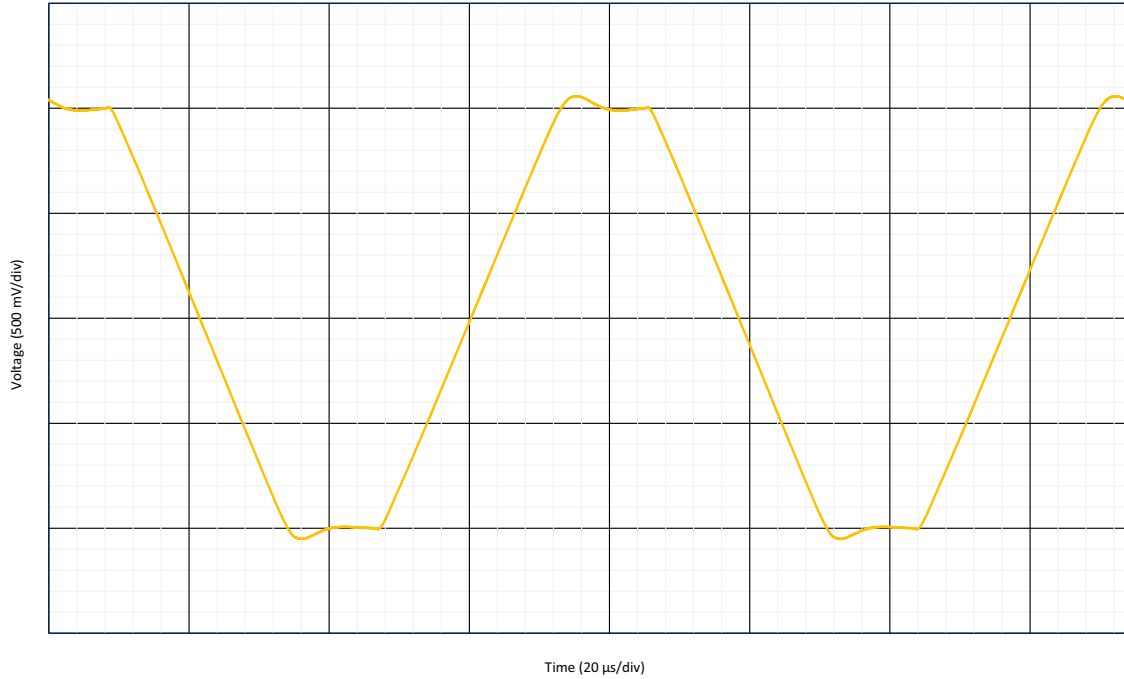

Figure 116: Large Signal Inverting Step Response $G = -1 \text{ V/V}$, $R_L = 50 \text{ k}\Omega$, $C_L = 80 \text{ pF}$, $BW = 128 \text{ kHz}$

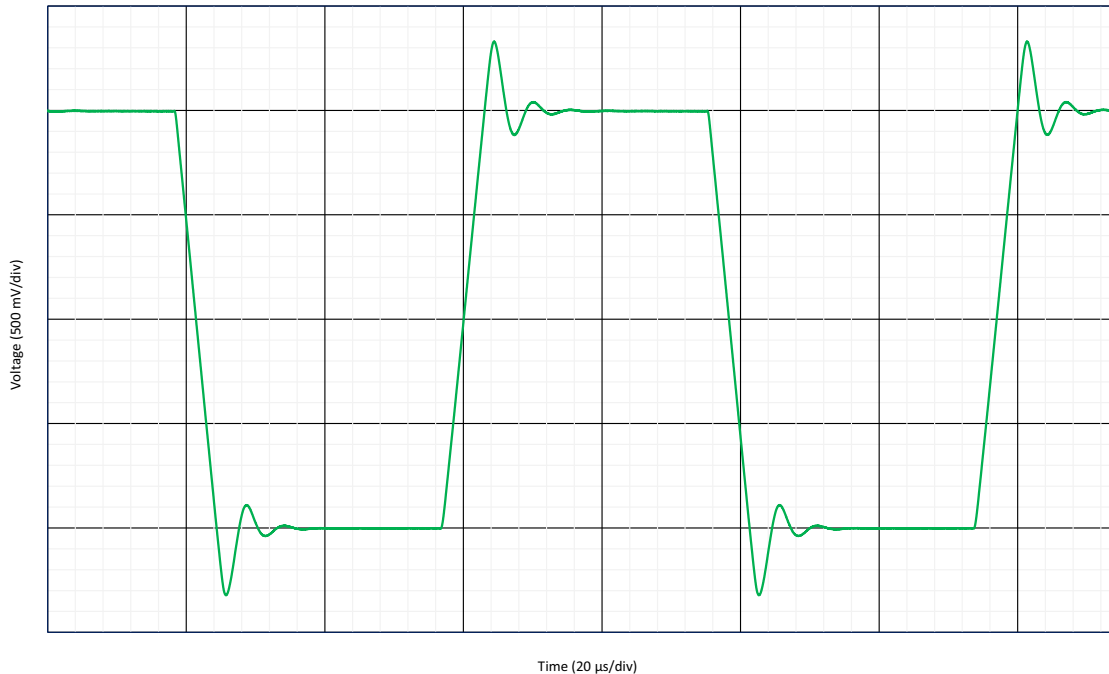

Figure 117: Large Signal Inverting Step Response $G = -1 \text{ V/V}$, $R_L = 50 \text{ k}\Omega$, $C_L = 80 \text{ pF}$, $BW = 512 \text{ kHz}$

SLG47004

GreenPAK Programmable Mixed-Signal Matrix
with In-System Programmability and Advanced Analog Features

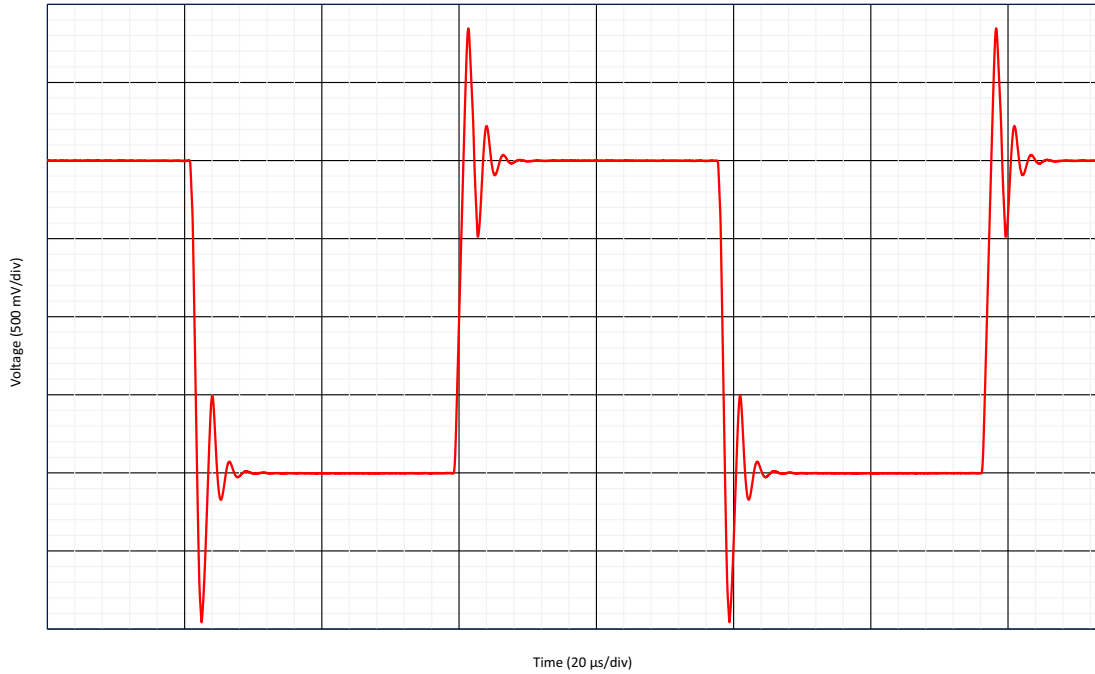

Figure 118: Large Signal Inverting Step Response $G = -1 \text{ V/V}$, $R_L = 50 \text{ k}\Omega$, $C_L = 80 \text{ pF}$, $BW = 2 \text{ MHz}$

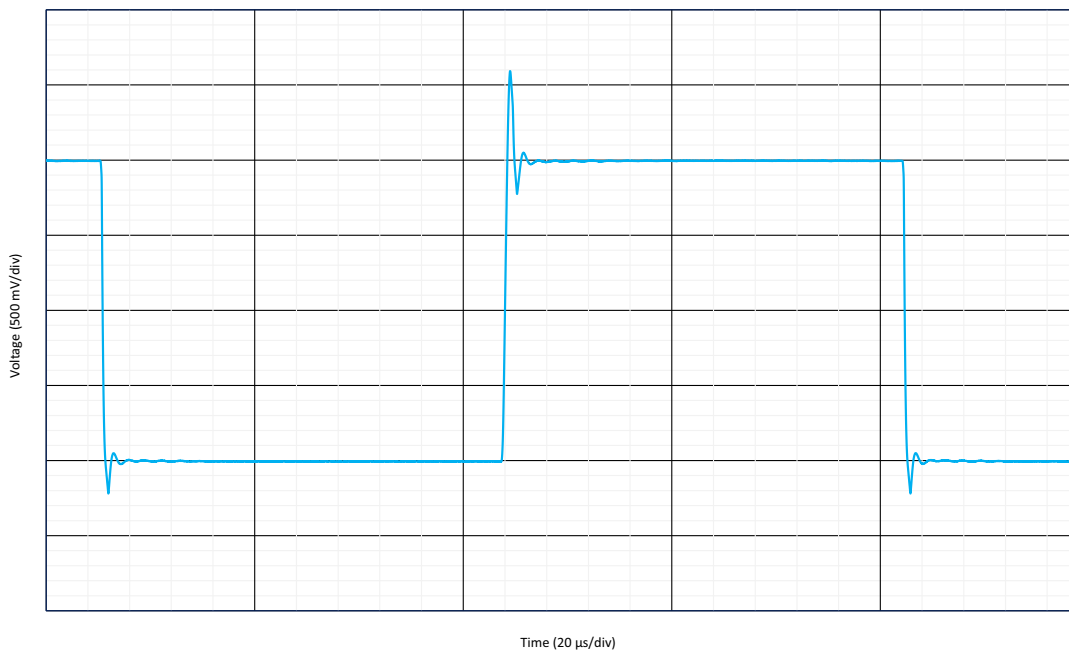

Figure 119: Large Signal Inverting Step Response $G = -1 \text{ V/V}$, $R_L = 50 \text{ k}\Omega$, $C_L = 80 \text{ pF}$, $BW = 8 \text{ MHz}$

SLG47004

GreenPAK Programmable Mixed-Signal Matrix
with In-System Programmability and Advanced Analog Features

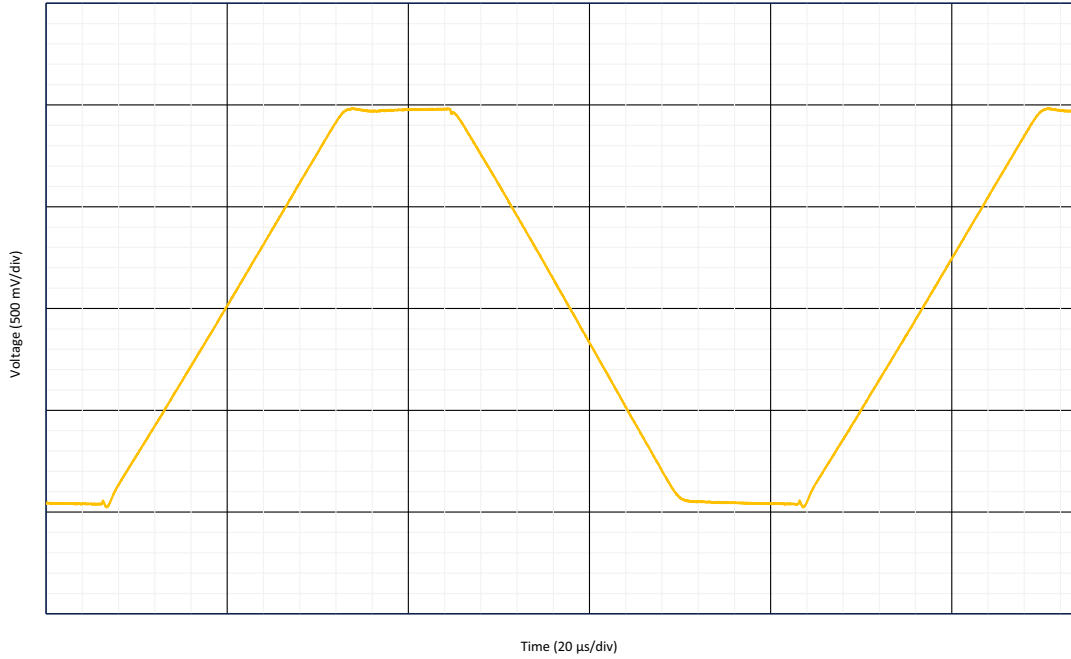

Figure 120: Large Signal Non-Inverting Step Response $G = -1 \text{ V/V}$, $R_L = 50 \text{ k}\Omega$, $C_L = 60 \text{ pF}$, $BW = 128 \text{ kHz}$

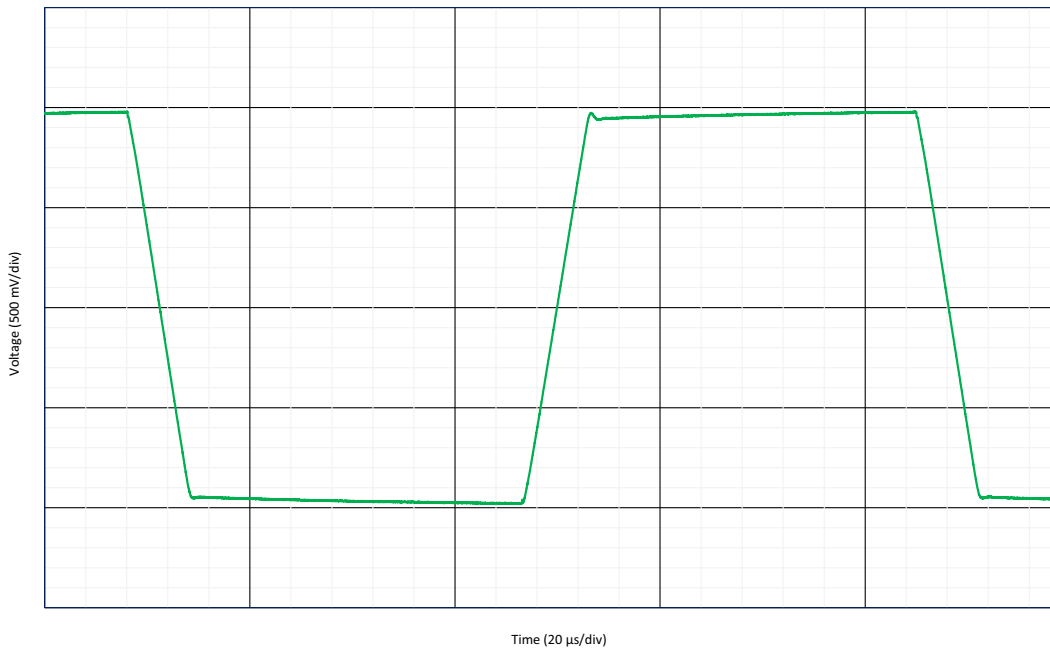

Figure 121: Large Signal Non-Inverting Step Response $G = -1 \text{ V/V}$, $R_L = 50 \text{ k}\Omega$, $C_L = 60 \text{ pF}$, $BW = 512 \text{ kHz}$

SLG47004

GreenPAK Programmable Mixed-Signal Matrix
with In-System Programmability and Advanced Analog Features

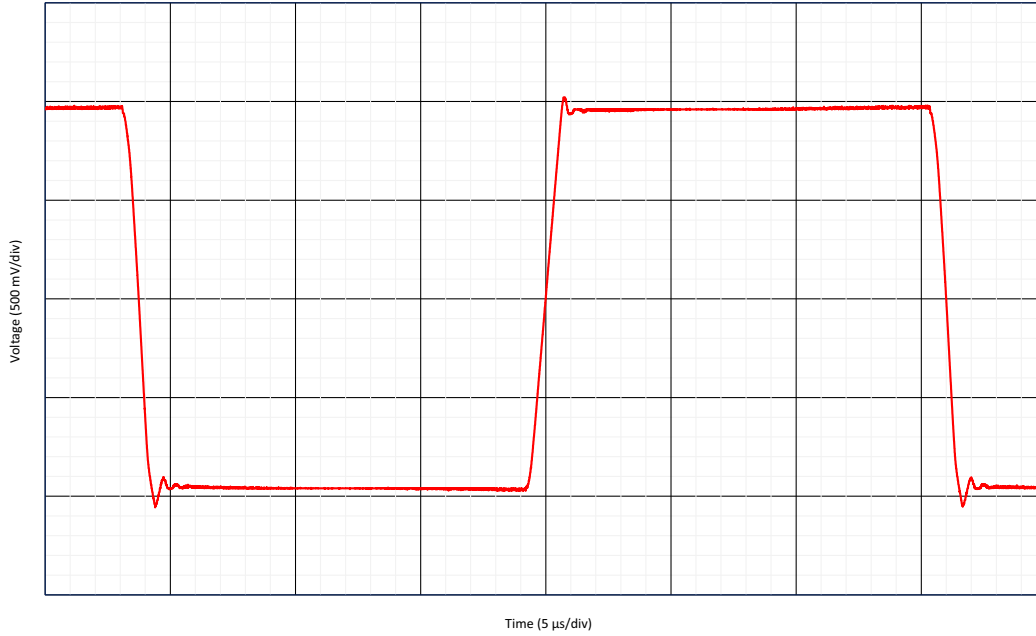

Figure 122: Large Signal Non-Inverting Step Response $G = -1 \text{ V/V}$, $R_L = 50 \text{ k}\Omega$, $C_L = 60 \text{ pF}$, $\text{BW} = 2 \text{ MHz}$

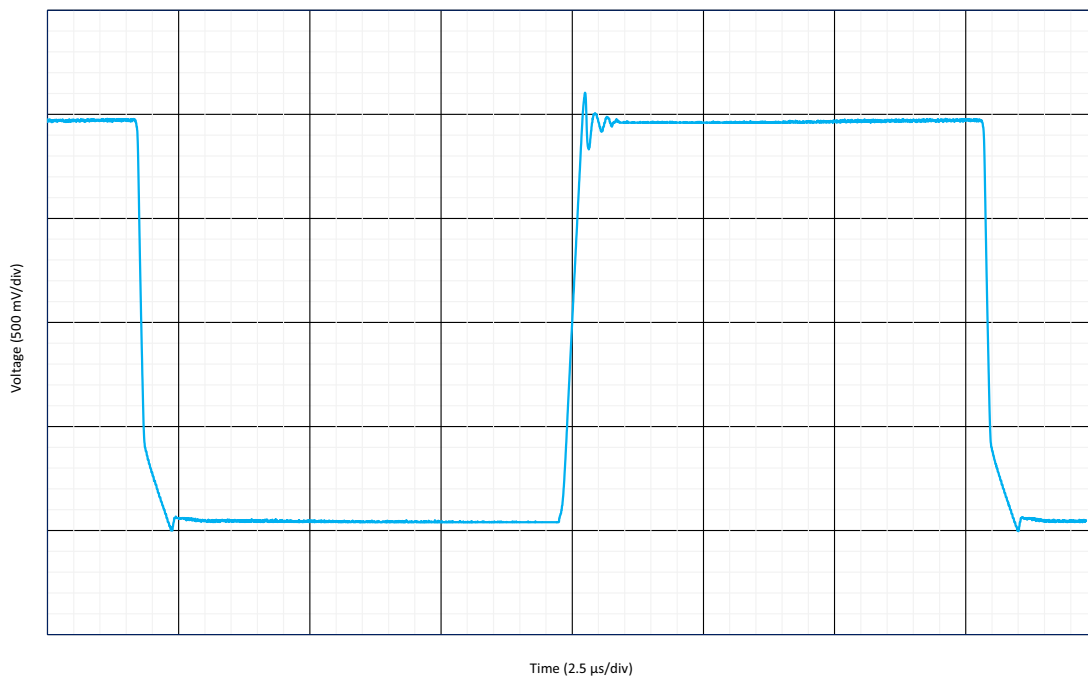

Figure 123: Large Signal Non-Inverting Step Response $G = -1 \text{ V/V}$, $R_L = 50 \text{ k}\Omega$, $C_L = 60 \text{ pF}$, $\text{BW} = 8 \text{ MHz}$

SLG47004

GreenPAK Programmable Mixed-Signal Matrix
with In-System Programmability and Advanced Analog Features

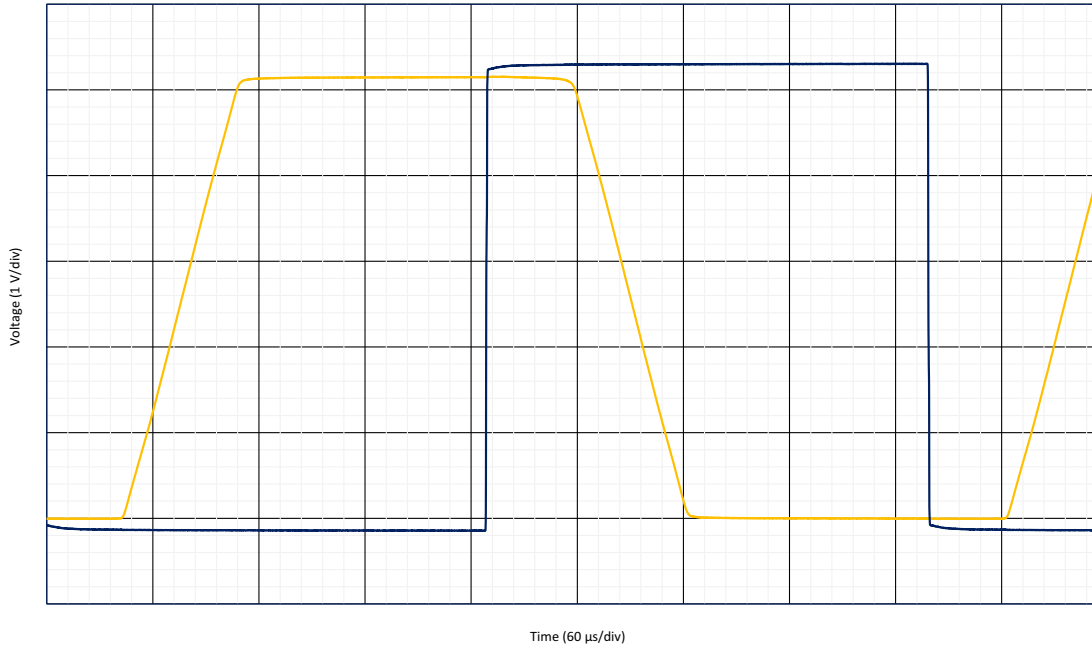

Figure 124: Inverting Overload Recovery $G = -1 \text{ V/V}$, $R_L = 50 \text{ k}\Omega$, $C_L = 60 \text{ pF}$, $BW = 128 \text{ kHz}$

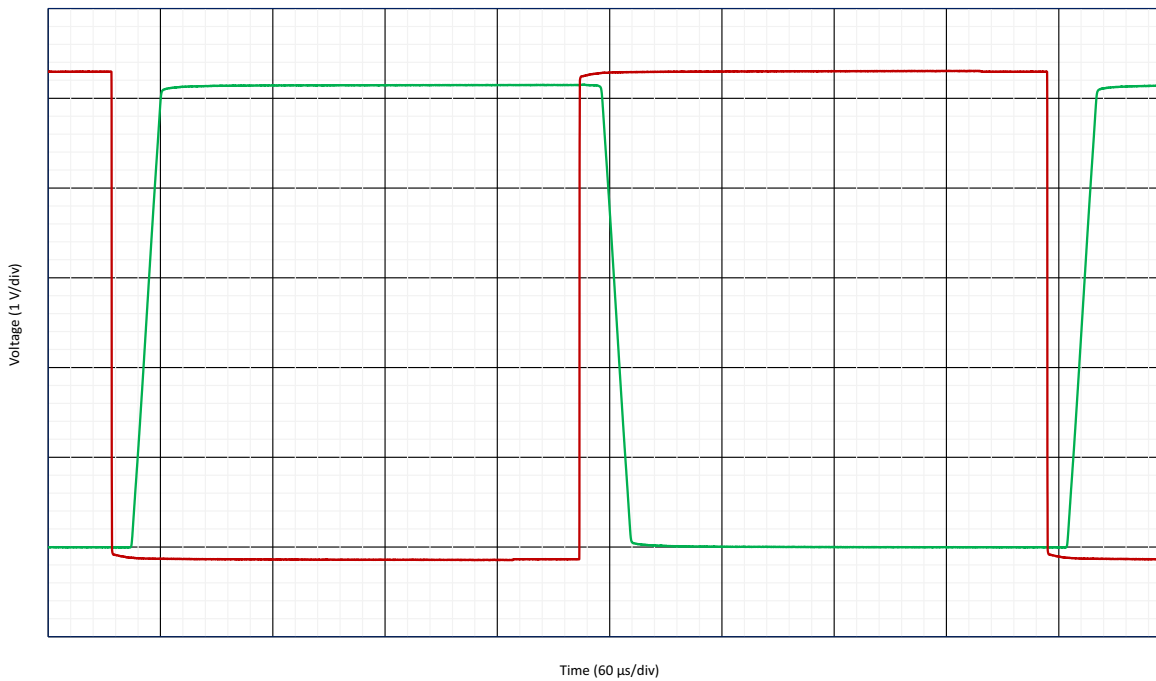

Figure 125: Inverting Overload Recovery $G = -1 \text{ V/V}$, $R_L = 50 \text{ k}\Omega$, $C_L = 60 \text{ pF}$, $BW = 512 \text{ kHz}$

SLG47004

GreenPAK Programmable Mixed-Signal Matrix
with In-System Programmability and Advanced Analog Features

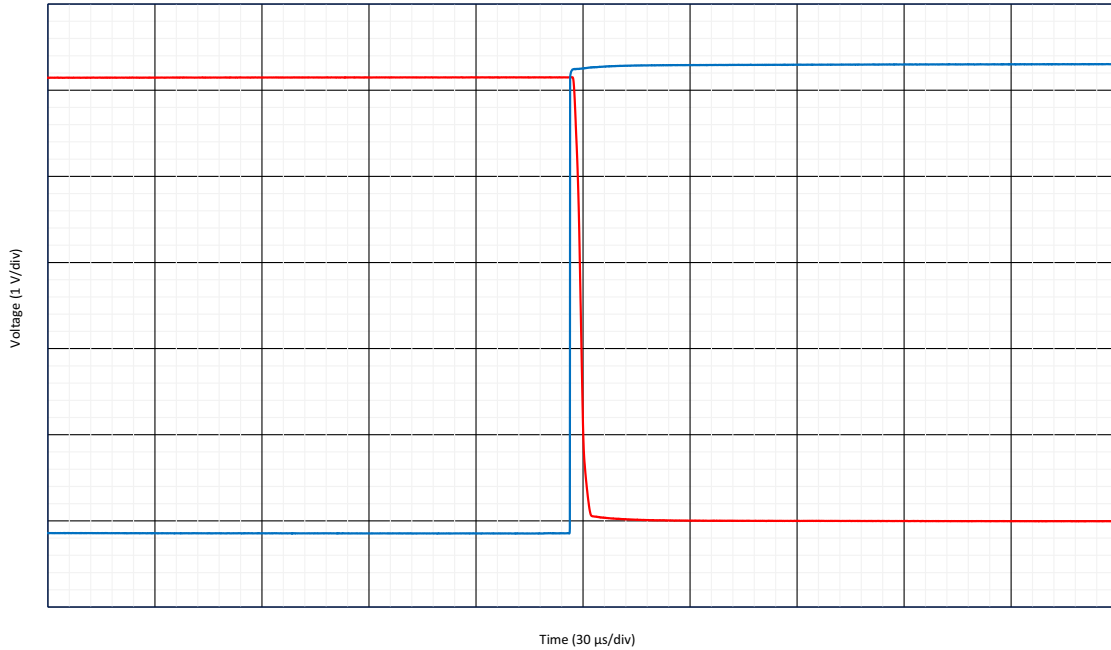

Figure 126: Inverting Overload Recovery $G = -1 \text{ V/V}$, $R_L = 50 \text{ k}\Omega$, $C_L = 60 \text{ pF}$, $BW = 2 \text{ MHz}$

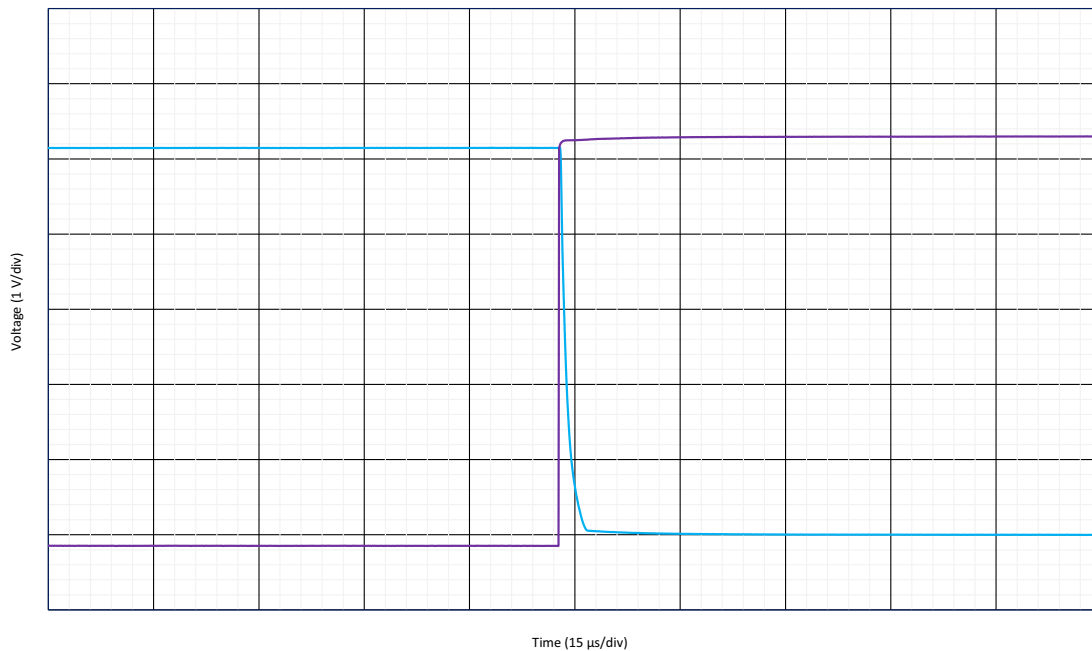

Figure 127: Inverting Overload Recovery $G = -1 \text{ V/V}$, $R_L = 50 \text{ k}\Omega$, $C_L = 60 \text{ pF}$, $BW = 8 \text{ MHz}$

SLG47004

GreenPAK Programmable Mixed-Signal Matrix
with In-System Programmability and Advanced Analog Features

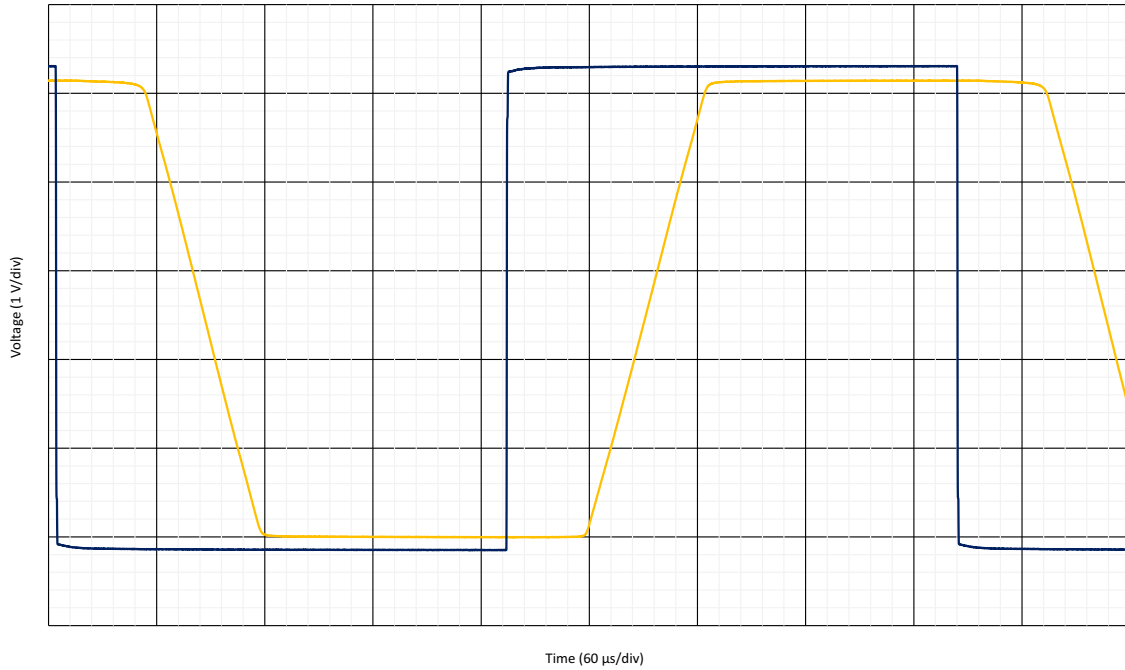

Figure 128: Non-Inverting Overload Recovery $G = -1$ V/V, $R_L = 50$ k Ω , $C_L = 60$ pF, BW = 128 kHz

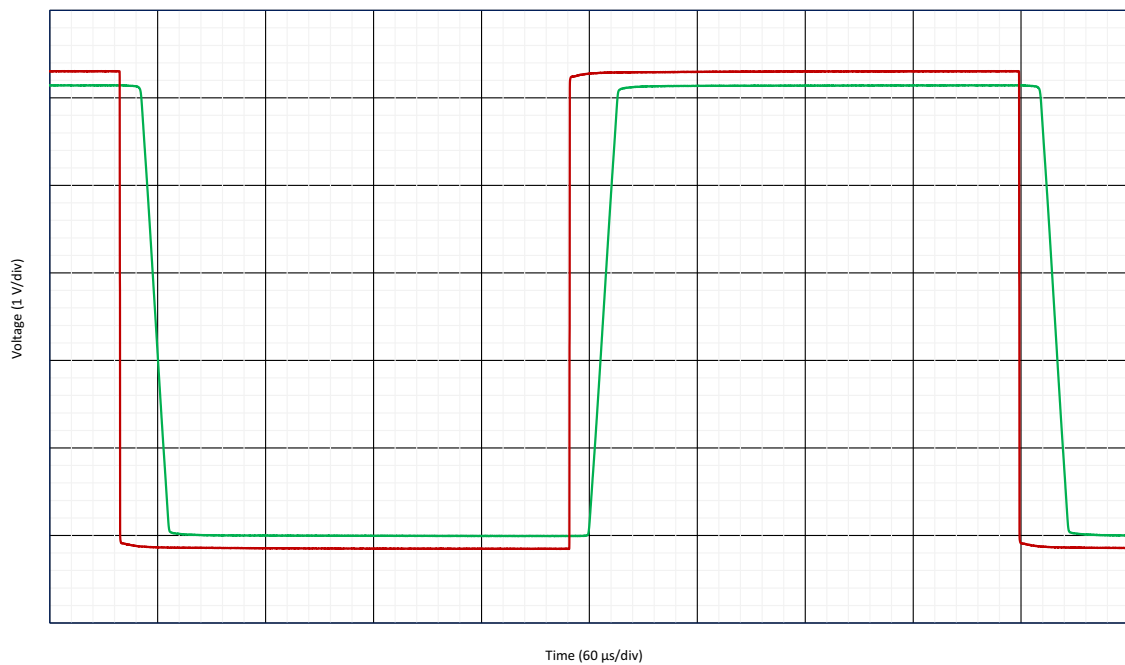

Figure 129: Non-Inverting Overload Recovery $G = -1$ V/V, $R_L = 50$ k Ω , $C_L = 60$ pF, BW = 512 kHz

SLG47004

GreenPAK Programmable Mixed-Signal Matrix
with In-System Programmability and Advanced Analog Features

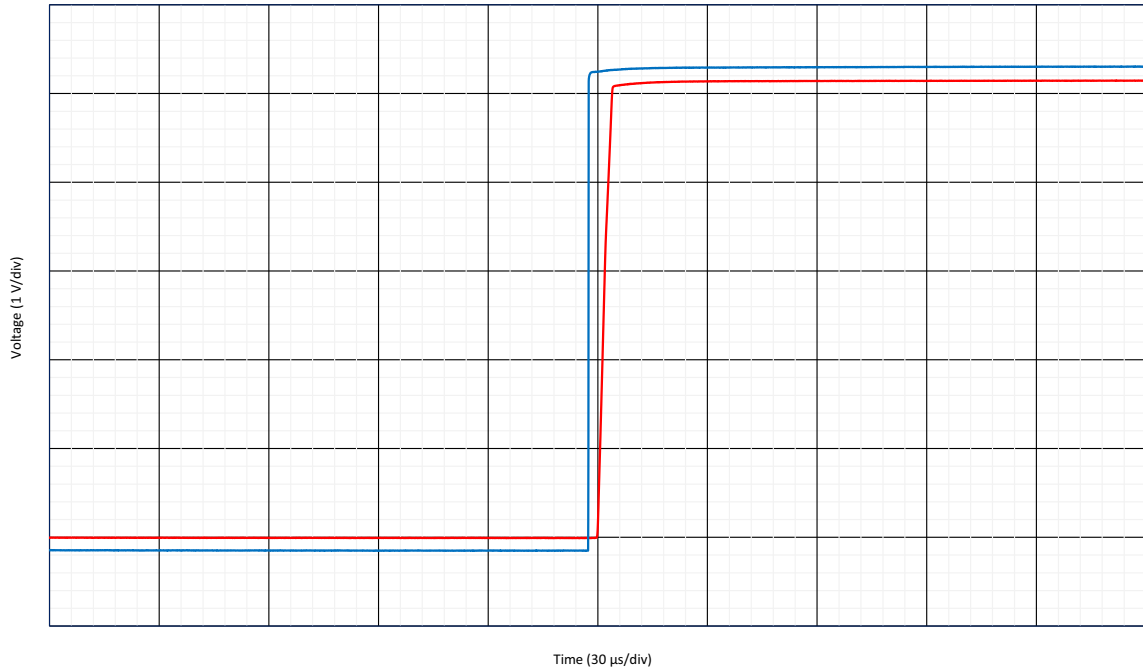

Figure 130: Non-Inverting Overload Recovery $G = -1 \text{ V/V}$, $R_L = 50 \text{ k}\Omega$, $C_L = 60 \text{ pF}$, $BW = 2 \text{ MHz}$

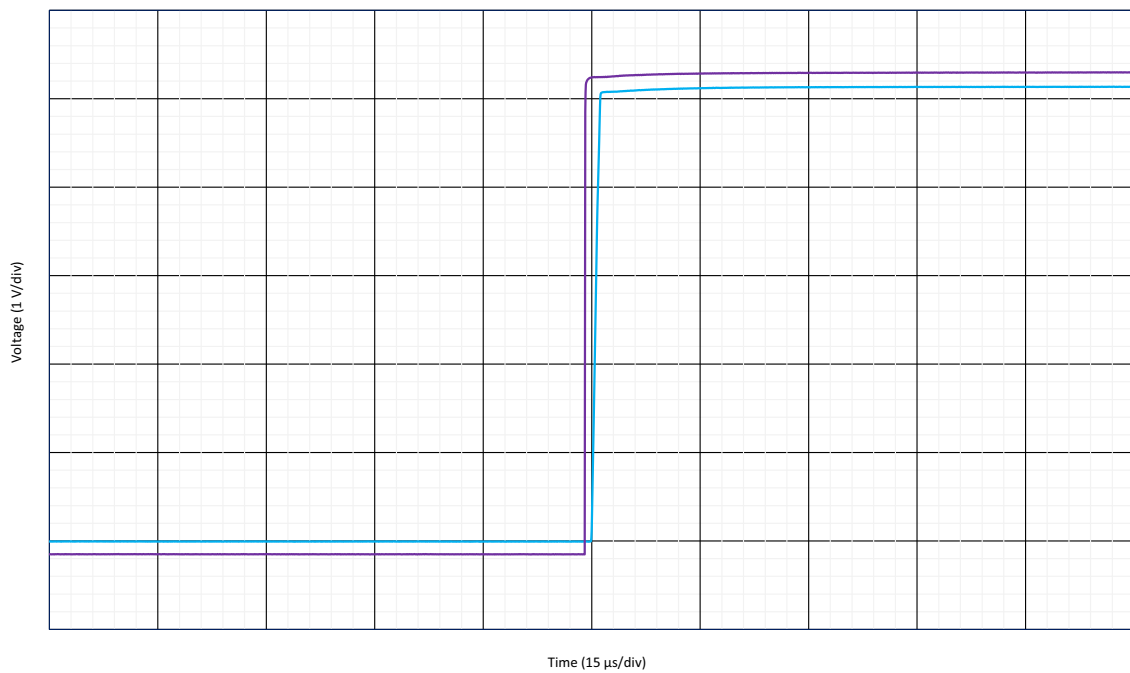

Figure 131: Non-Inverting Overload Recovery $G = -1 \text{ V/V}$, $R_L = 50 \text{ k}\Omega$, $C_L = 60 \text{ pF}$, $BW = 8 \text{ MHz}$

SLG47004

GreenPAK Programmable Mixed-Signal Matrix
with In-System Programmability and Advanced Analog Features

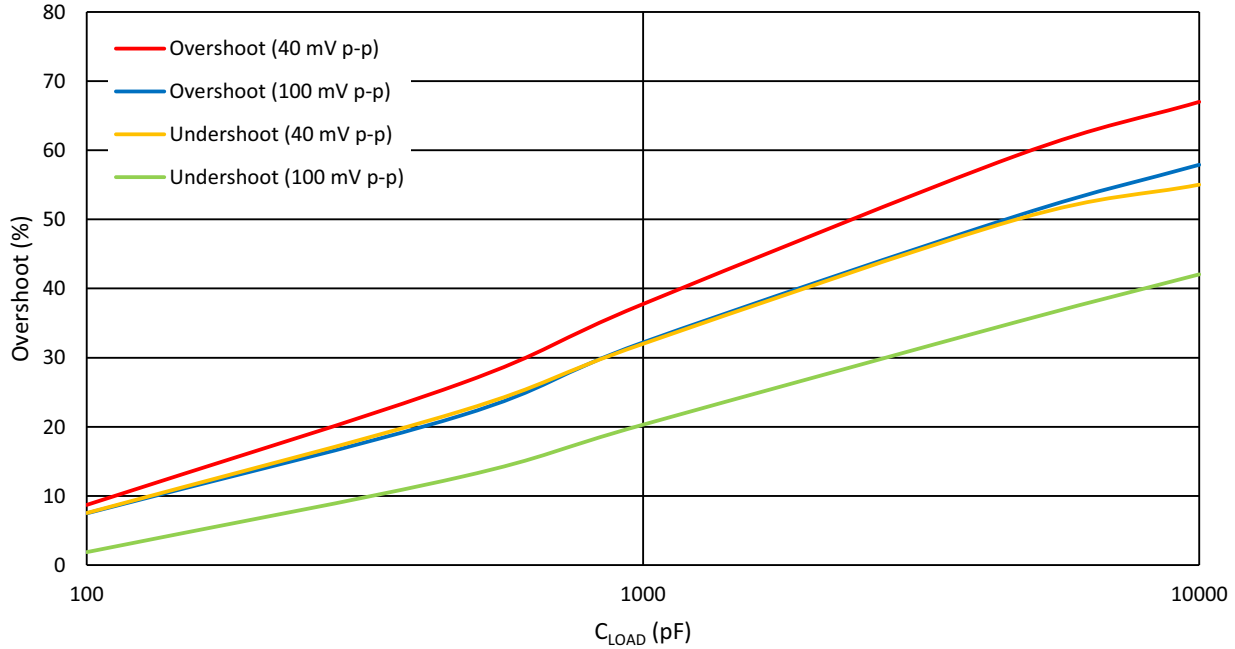

Figure 132: Small Signal Overshoot vs. Capacitive Load $V_{DD} = 3.3\text{ V}$, $G = 1\text{ V/V}$, $BW = 128\text{ kHz}$

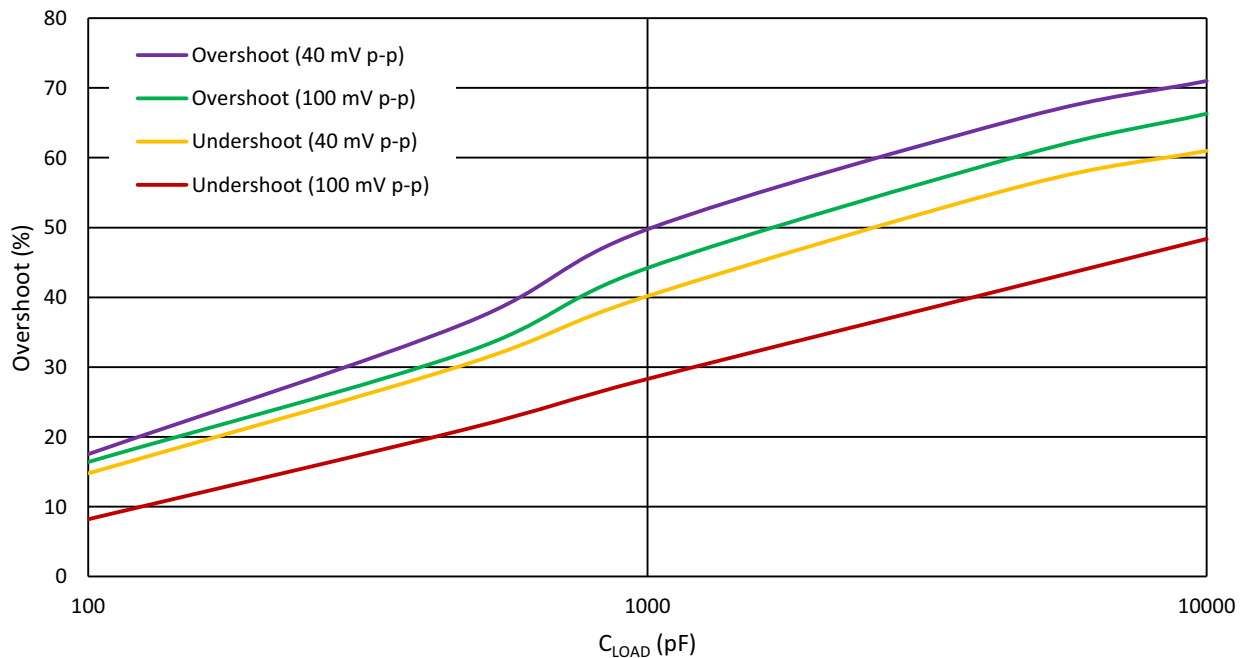

Figure 133: Small Signal Overshoot vs. Capacitive Load $V_{DD} = 3.3\text{ V}$, $G = 1\text{ V/V}$, $BW = 512\text{ kHz}$

SLG47004

GreenPAK Programmable Mixed-Signal Matrix
with In-System Programmability and Advanced Analog Features

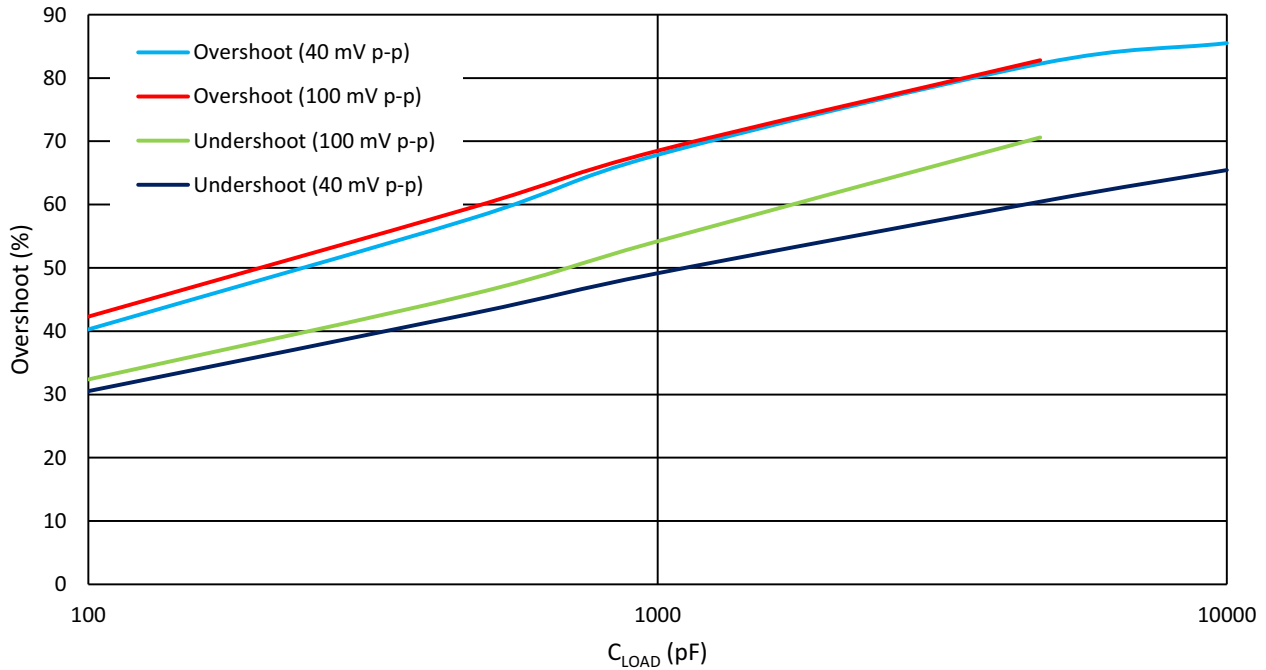

Figure 134: Small Signal Overshoot vs. Capacitive Load $V_{DD} = 3.3\text{ V}$, $G = 1\text{ V/V}$, $BW = 2\text{ MHz}$

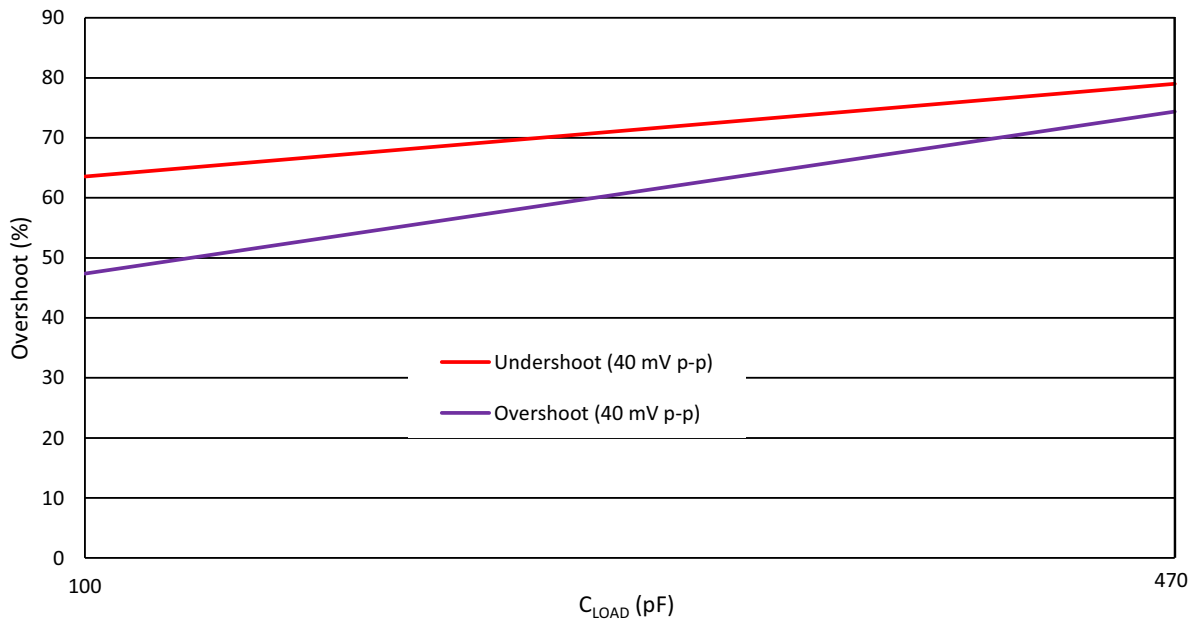

Figure 135: Small Signal Overshoot vs. Capacitive Load $V_{DD} = 3.3\text{ V}$, $G = 1\text{ V/V}$, $BW = 8\text{ MHz}$

SLG47004

GreenPAK Programmable Mixed-Signal Matrix with In-System Programmability and Advanced Analog Features

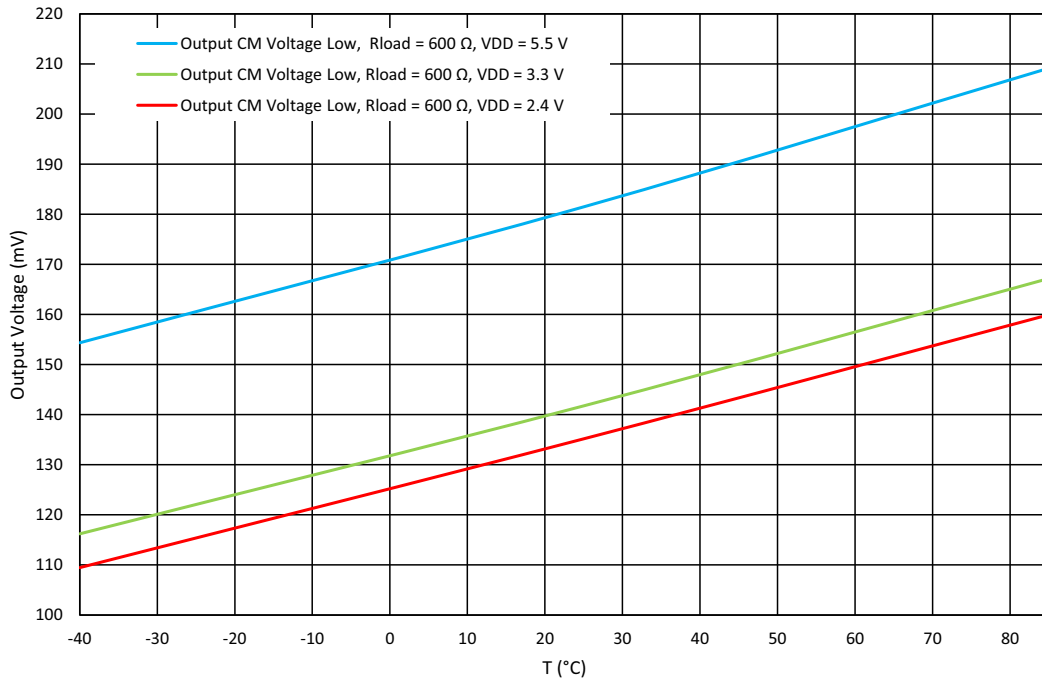

Figure 136: Output Voltage Low ($V_{OUT} - GND$) vs. Temperature at $BW = 128\text{ kHz}$, $R_{LOAD} = 600\ \Omega$

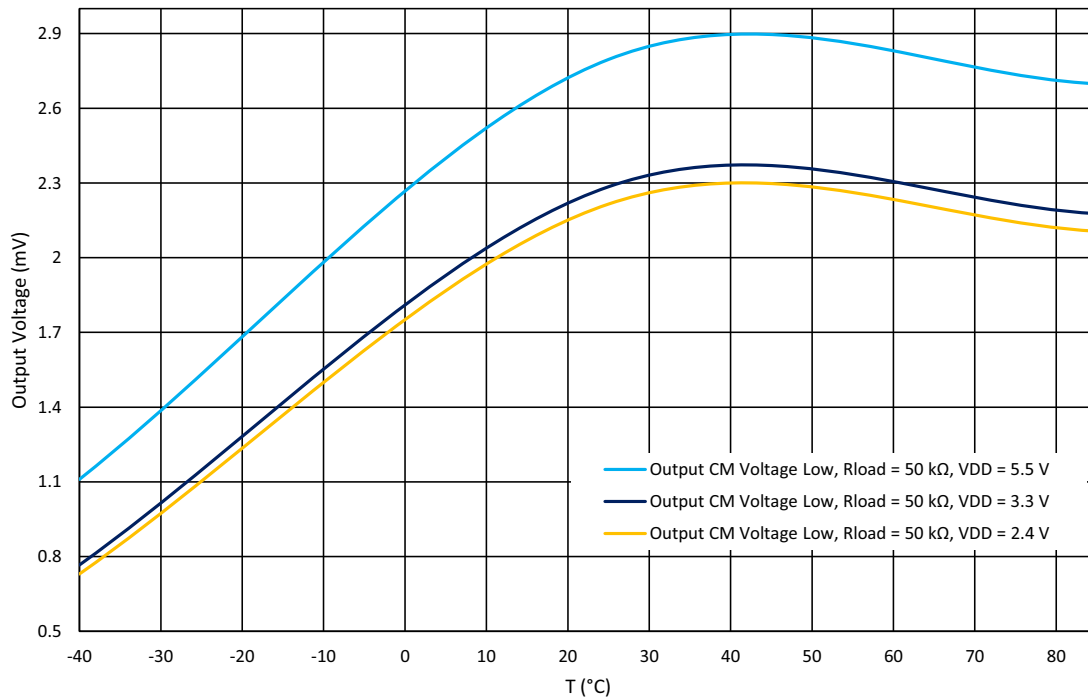

Figure 137: Output Voltage Low ($V_{OUT} - GND$) vs. Temperature at $BW = 128\text{ kHz}$, $R_{LOAD} = 50\text{ k}\Omega$

SLG47004

GreenPAK Programmable Mixed-Signal Matrix with In-System Programmability and Advanced Analog Features

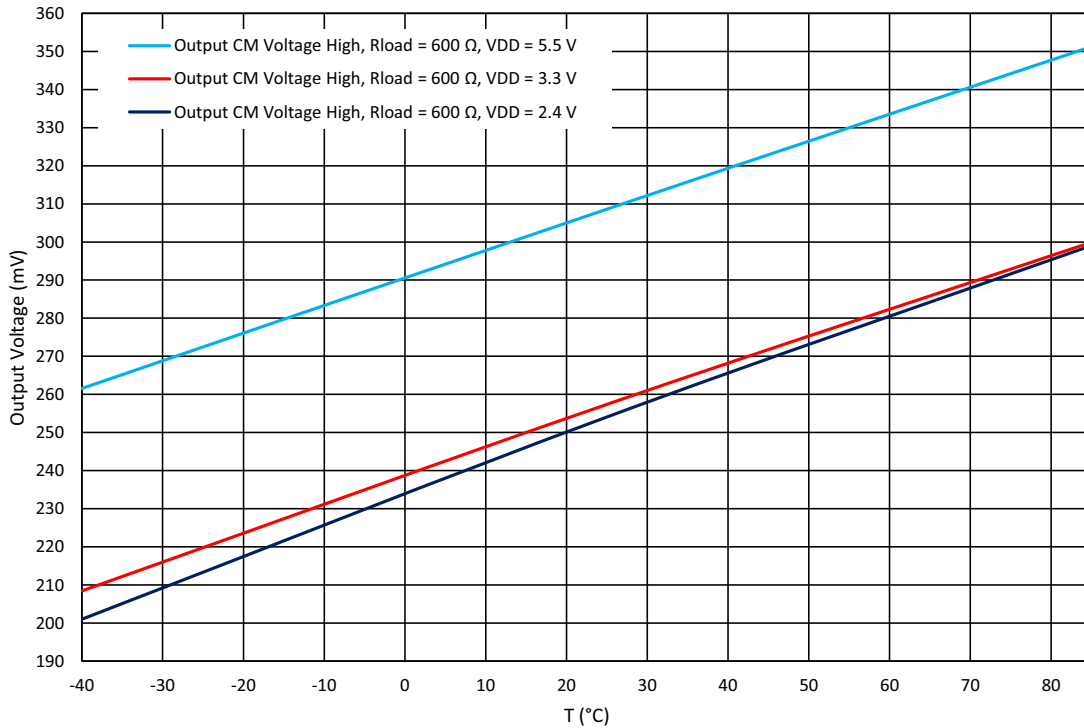

Figure 138: Output Voltage High ($V_{DDA} - V_{OUT}$) vs. Temperature at BW = 128 kHz, $R_{LOAD} = 600 \Omega$

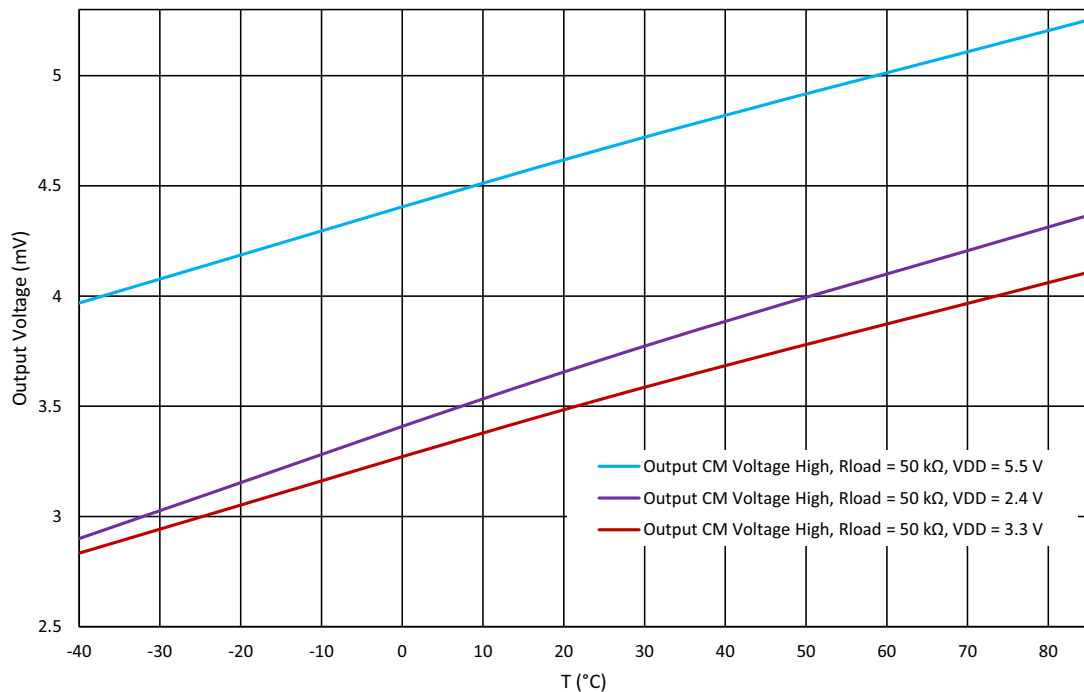

Figure 139: Output Voltage High ($V_{DDA} - V_{OUT}$) vs. Temperature at BW = 128 kHz, $R_{LOAD} = 50 \text{ k}\Omega$

SLG47004

GreenPAK Programmable Mixed-Signal Matrix with In-System Programmability and Advanced Analog Features

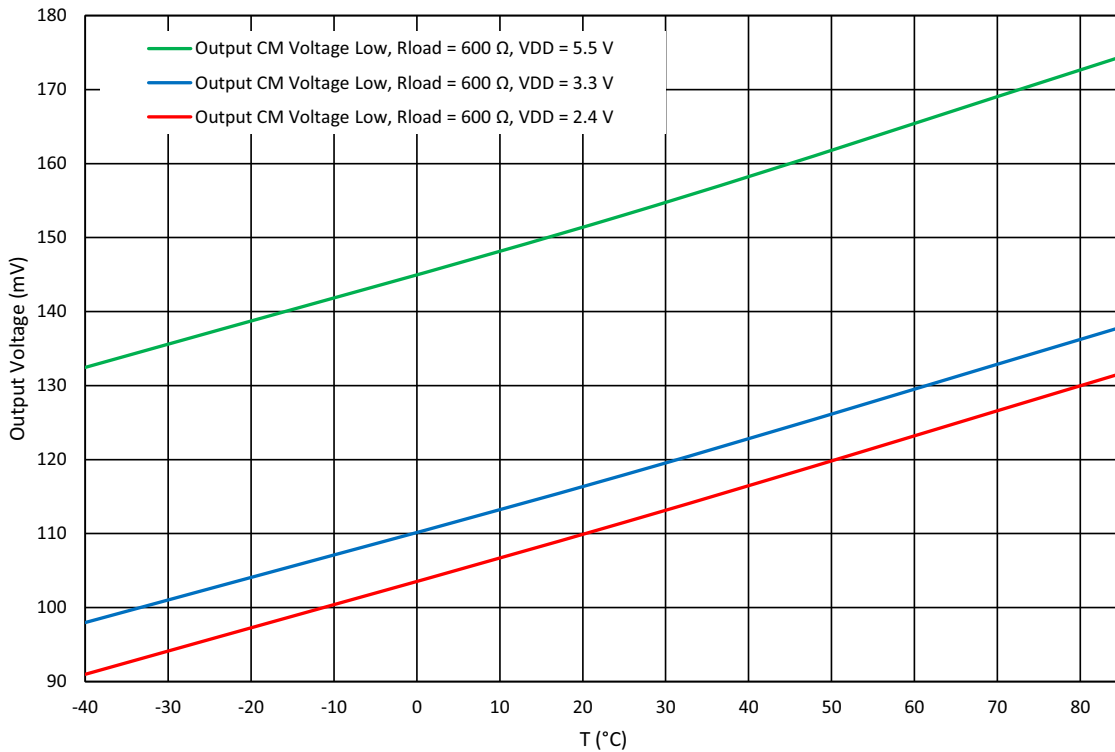

Figure 140: Output Voltage Low ($V_{OUT} - GND$) vs. Temperature at BW = 512 kHz, $R_{LOAD} = 600 \Omega$

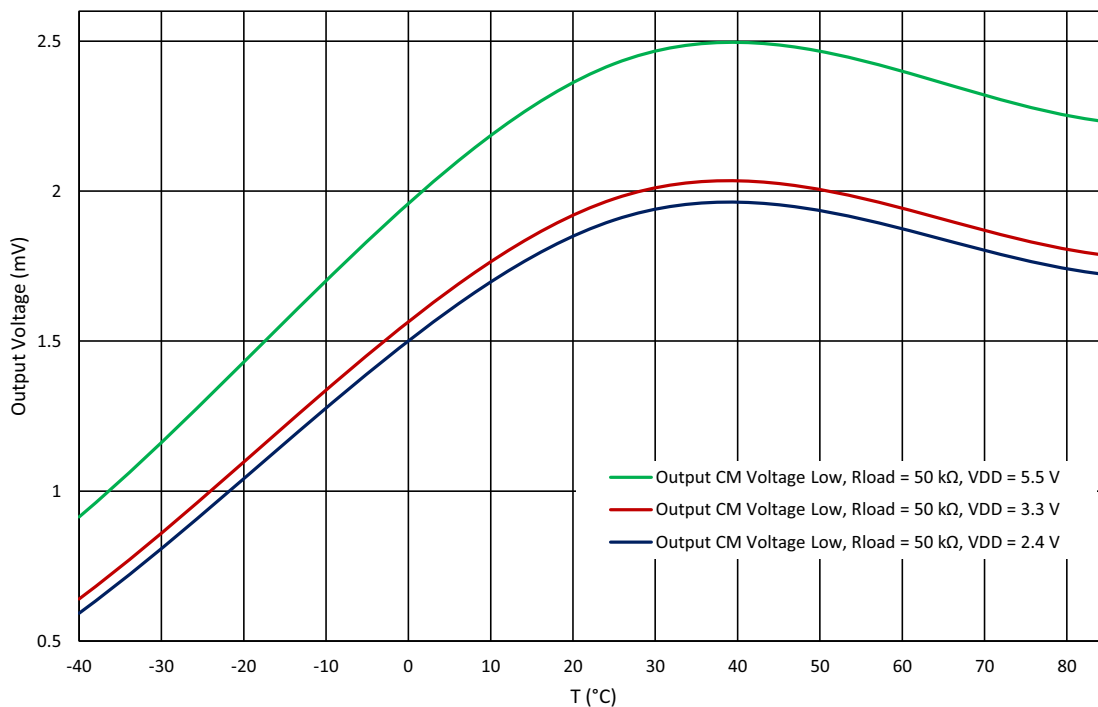

Figure 141: Output Voltage Low ($V_{OUT} - GND$) vs. Temperature at BW = 512 kHz, $R_{LOAD} = 50 \text{ k}\Omega$

SLG47004

GreenPAK Programmable Mixed-Signal Matrix with In-System Programmability and Advanced Analog Features

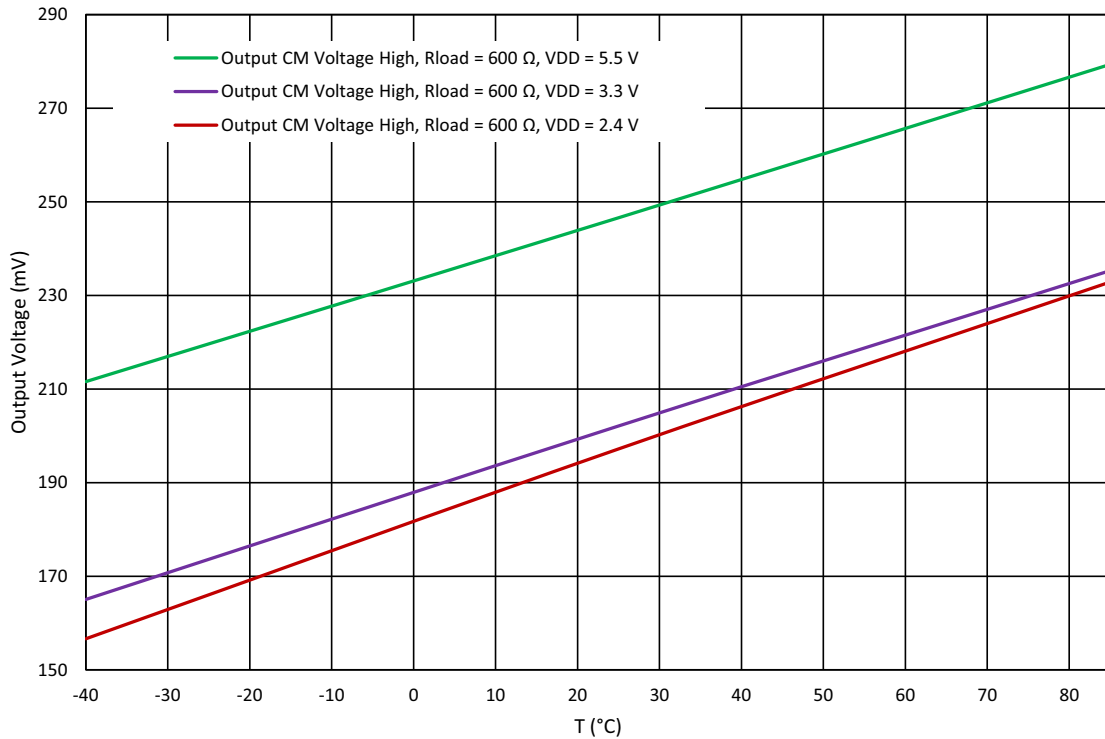

Figure 142: Output Voltage High ($V_{DDA} - V_{OUT}$) vs. Temperature at BW = 512 kHz, $R_{LOAD} = 600 \Omega$

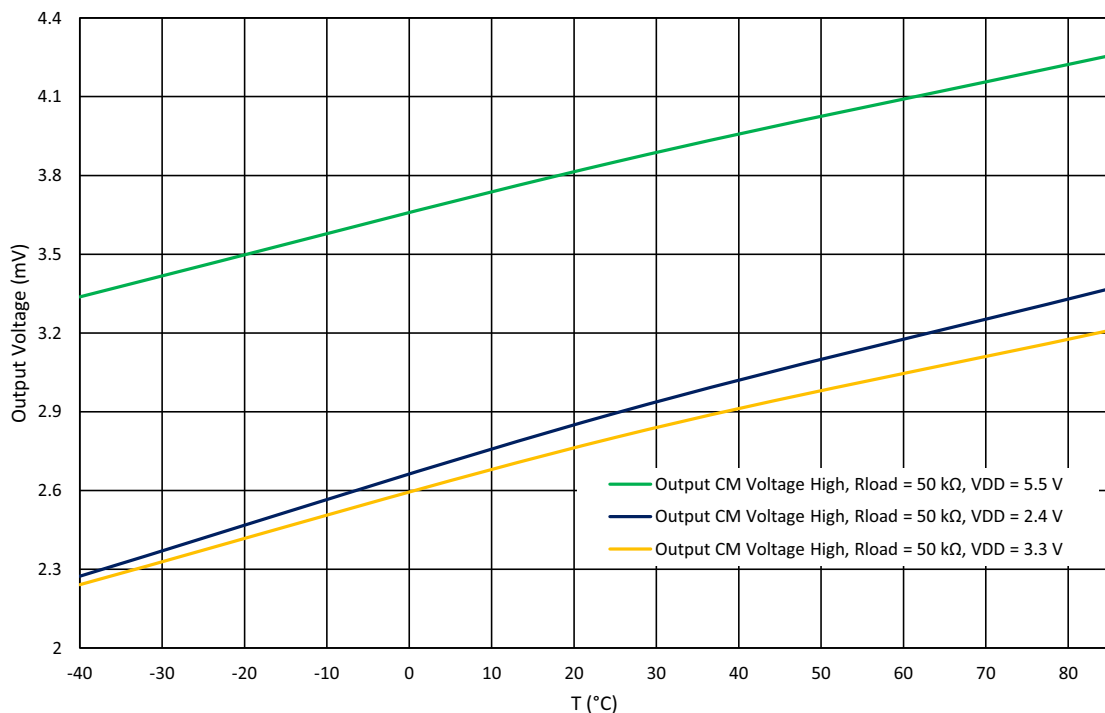

Figure 143: Output Voltage High ($V_{DDA} - V_{OUT}$) vs. Temperature at BW = 512kHz, $R_{LOAD} = 50 \text{ k}\Omega$

SLG47004

GreenPAK Programmable Mixed-Signal Matrix with In-System Programmability and Advanced Analog Features

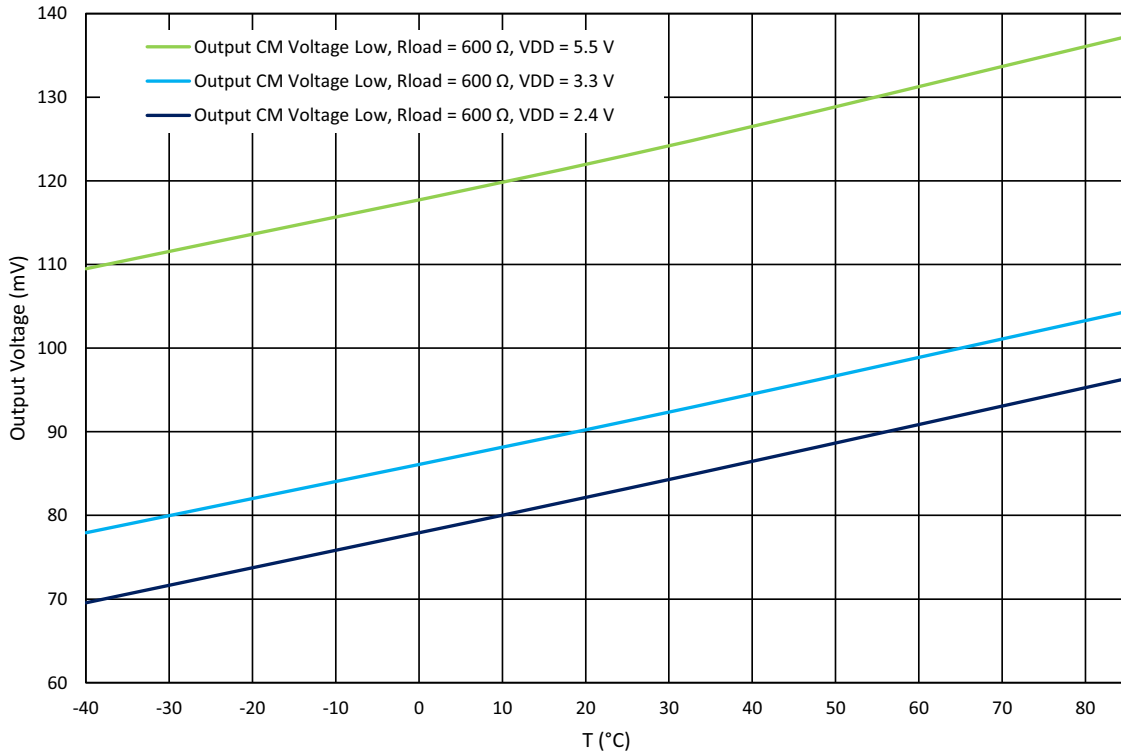

Figure 144: Output Voltage Low ($V_{OUT} - GND$) vs. Temperature at BW = 2 MHz, $R_{LOAD} = 600 \Omega$

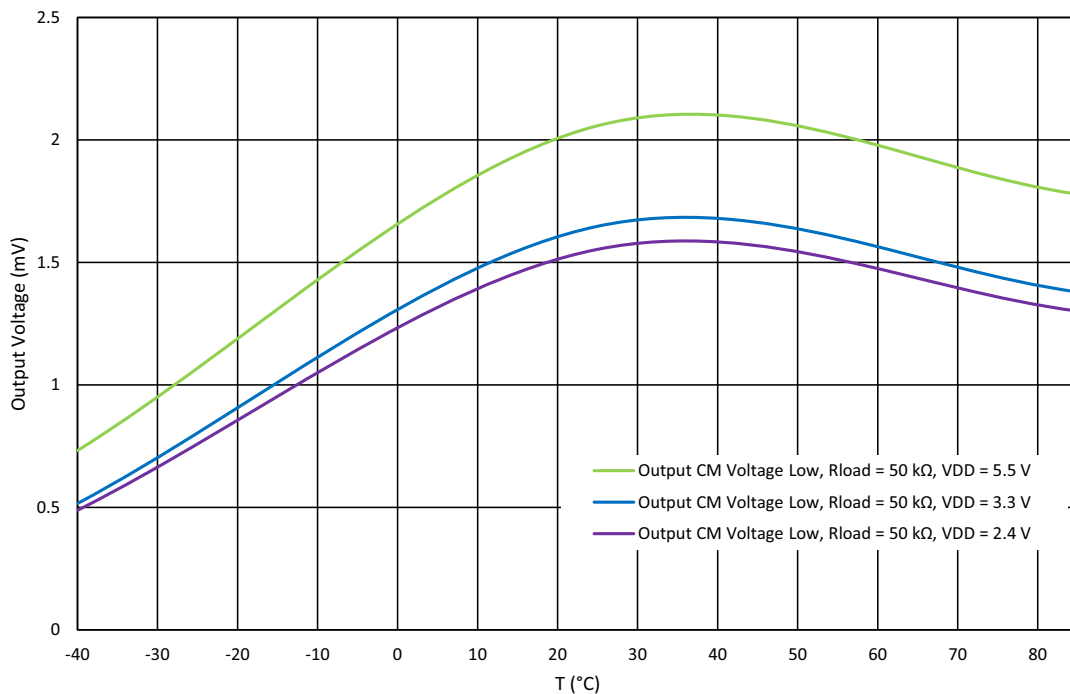

Figure 145: Output Voltage Low ($V_{OUT} - GND$) vs. Temperature at BW = 2 MHz, $R_{LOAD} = 50 k\Omega$

SLG47004

GreenPAK Programmable Mixed-Signal Matrix with In-System Programmability and Advanced Analog Features

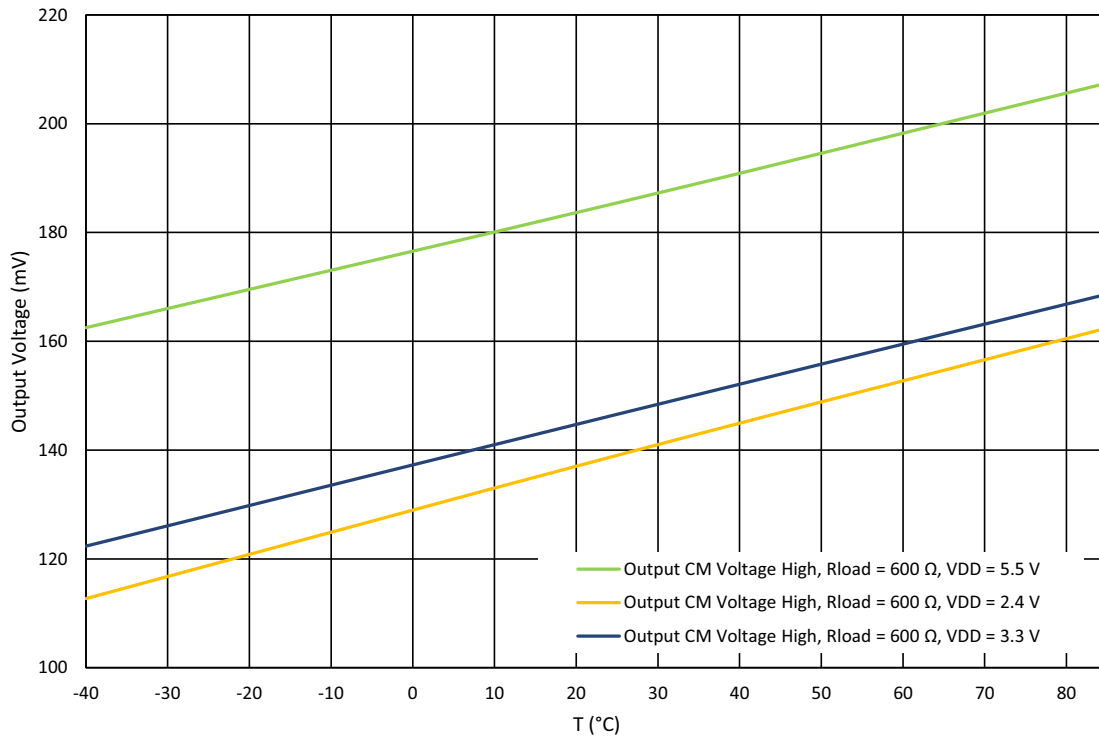

Figure 146: Output Voltage High (V_{DDA} - V_{OUT}) vs. Temperature at BW = 2 MHz, R_{LOAD} = 600 Ω

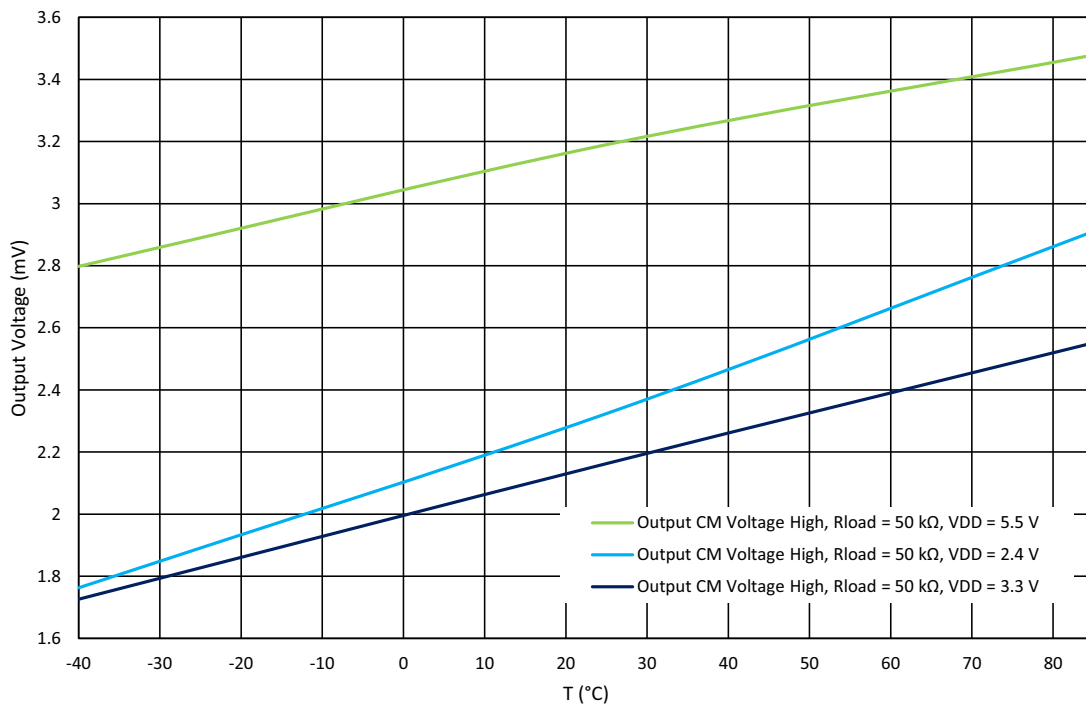

Figure 147: Output Voltage High (V_{DDA} - V_{OUT}) vs. Temperature at BW = 2 MHz, R_{LOAD} = 50 kΩ

SLG47004

GreenPAK Programmable Mixed-Signal Matrix with In-System Programmability and Advanced Analog Features

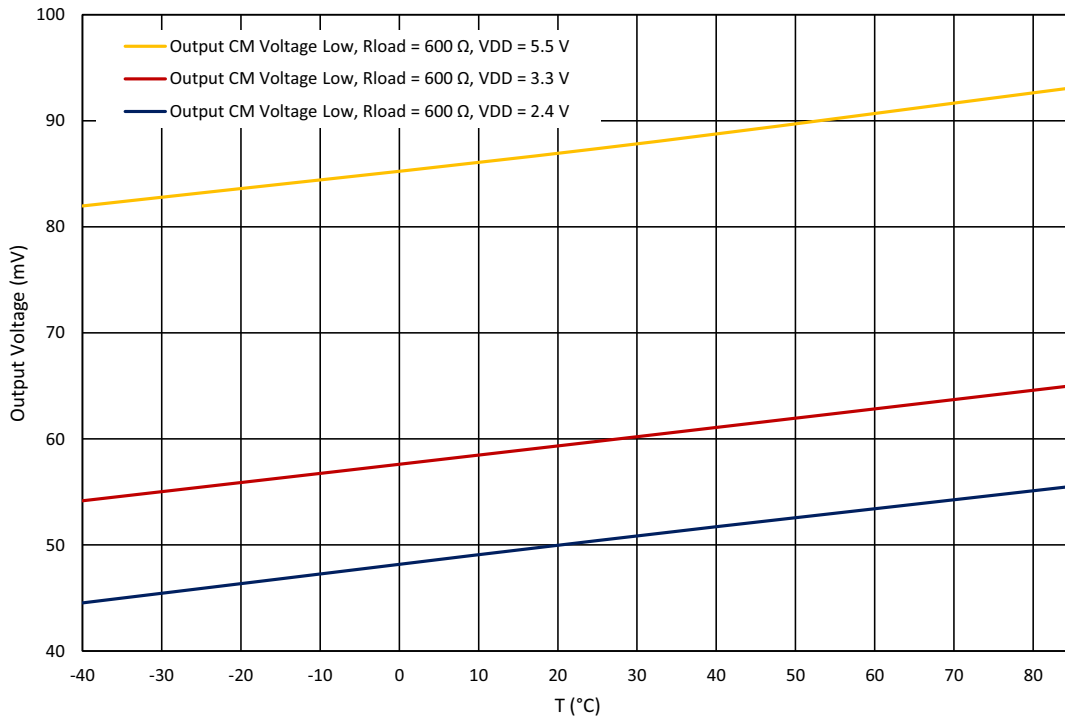

Figure 148: Output Voltage Low ($V_{OUT} - GND$) vs. Temperature at $BW = 8MHz$, $R_{LOAD} = 600 \Omega$

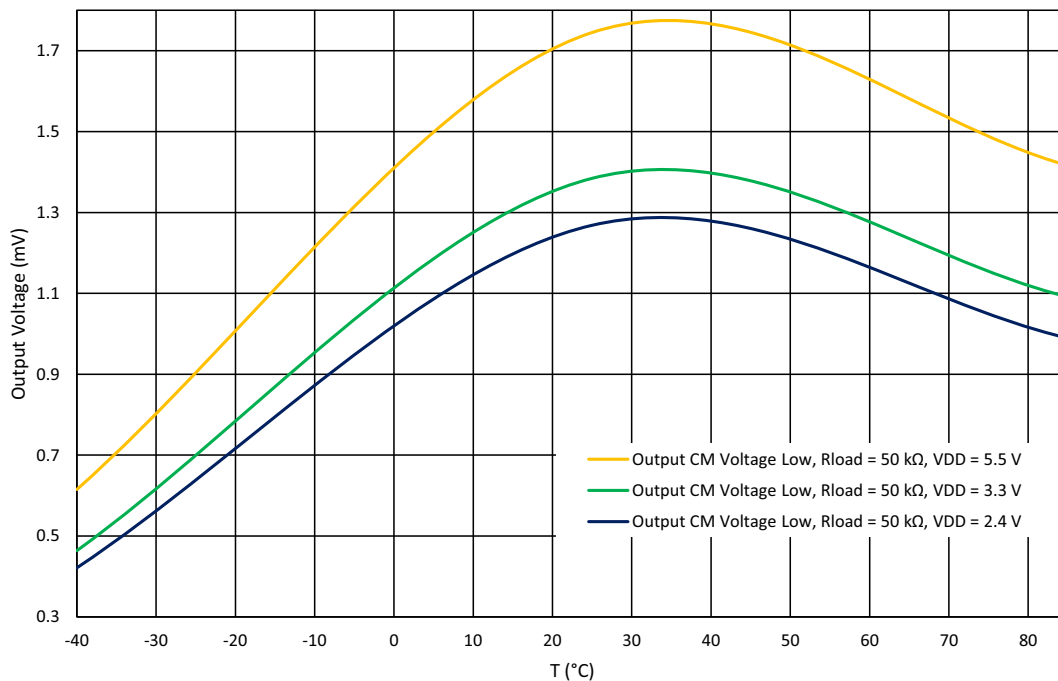

Figure 149: Output Voltage Low ($V_{OUT} - GND$) vs. Temperature at $BW = 8 MHz$, $R_{LOAD} = 50 k\Omega$

SLG47004

GreenPAK Programmable Mixed-Signal Matrix
with In-System Programmability and Advanced Analog Features

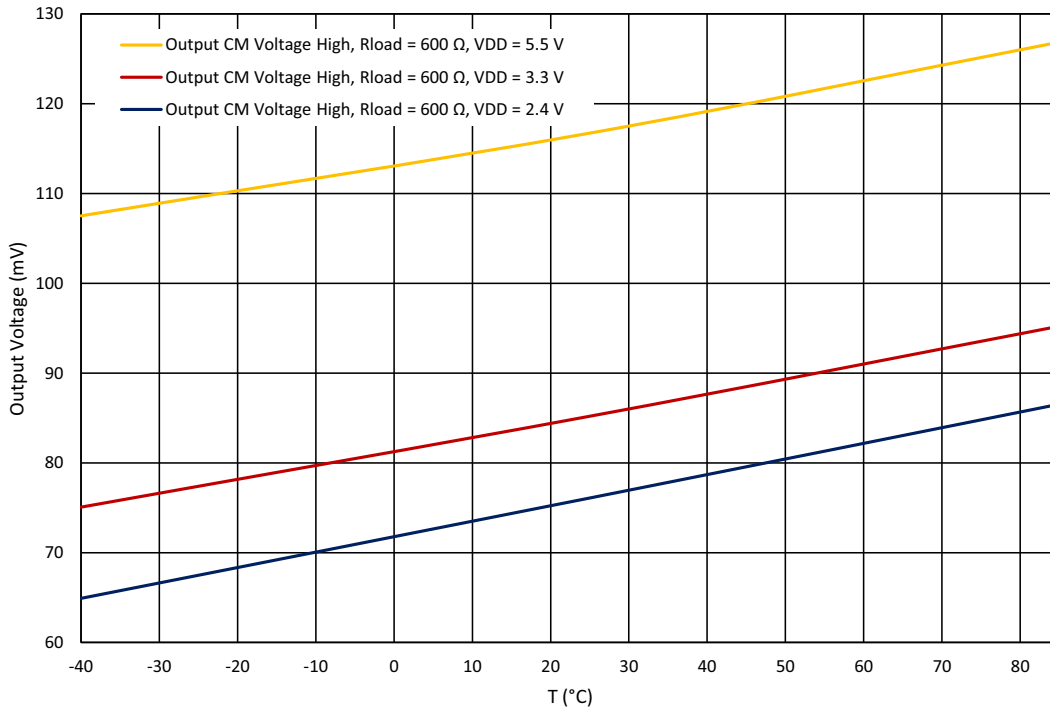

Figure 150: Output Voltage High ($V_{DDA} - V_{OUT}$) vs. Temperature at BW = 8 MHz, $R_{LOAD} = 600 \Omega$

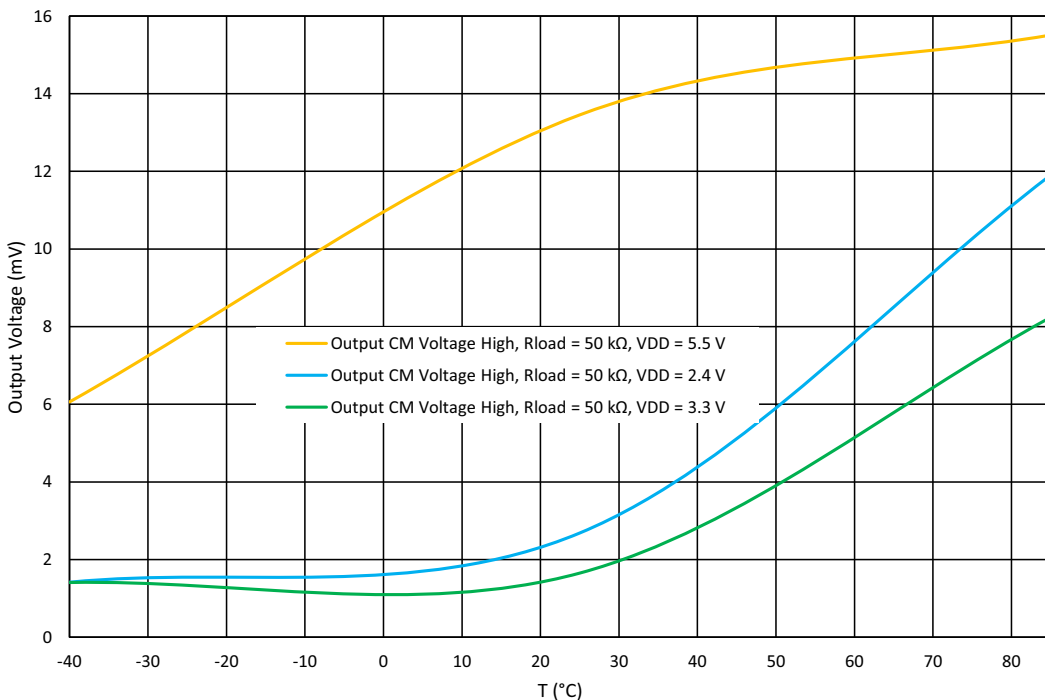

Figure 151: Output Voltage High ($V_{DDA} - V_{OUT}$) vs. Temperature at BW = 8 MHz, $R_{LOAD} = 50 k\Omega$

SLG47004

GreenPAK Programmable Mixed-Signal Matrix
with In-System Programmability and Advanced Analog Features

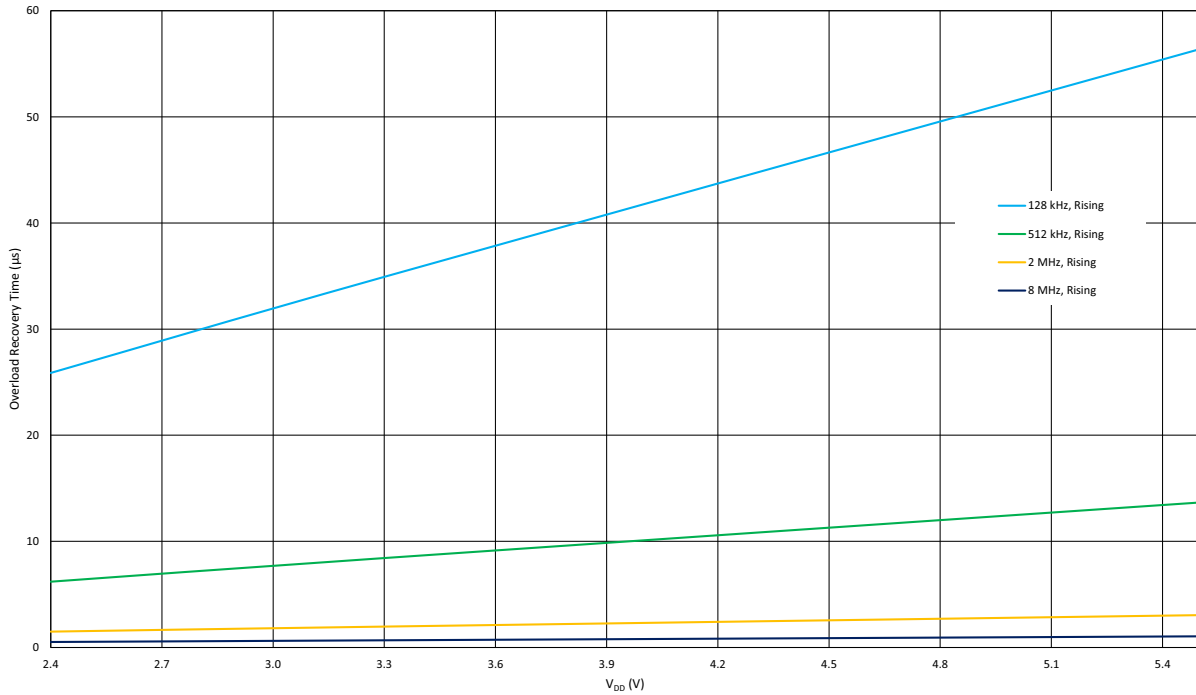

Figure 152: Overload Recovery Time vs. Power Supply Voltage $R_L = 50\text{ k}\Omega$; $G = 1\text{ V/V}$, Rising

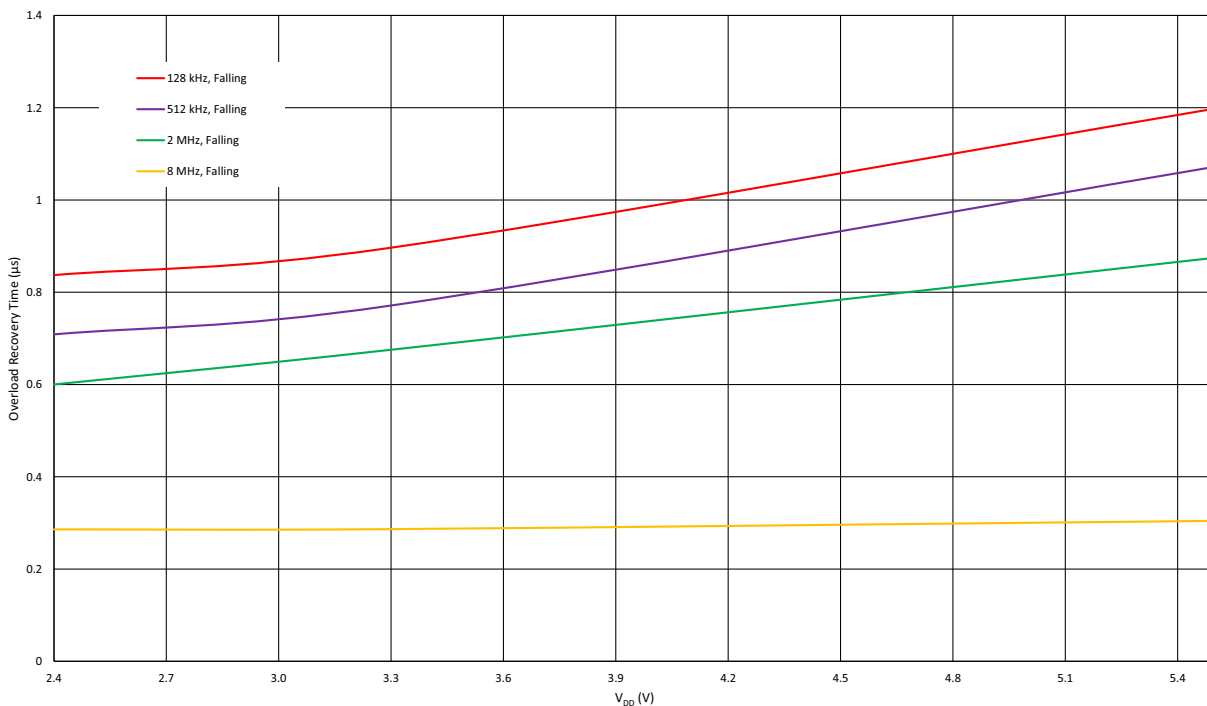

Figure 153: Overload Recovery Time vs. Power Supply Voltage $R_L = 50\text{ k}\Omega$; $G = 1\text{ V/V}$, Falling

SLG47004

GreenPAK Programmable Mixed-Signal Matrix
with In-System Programmability and Advanced Analog Features

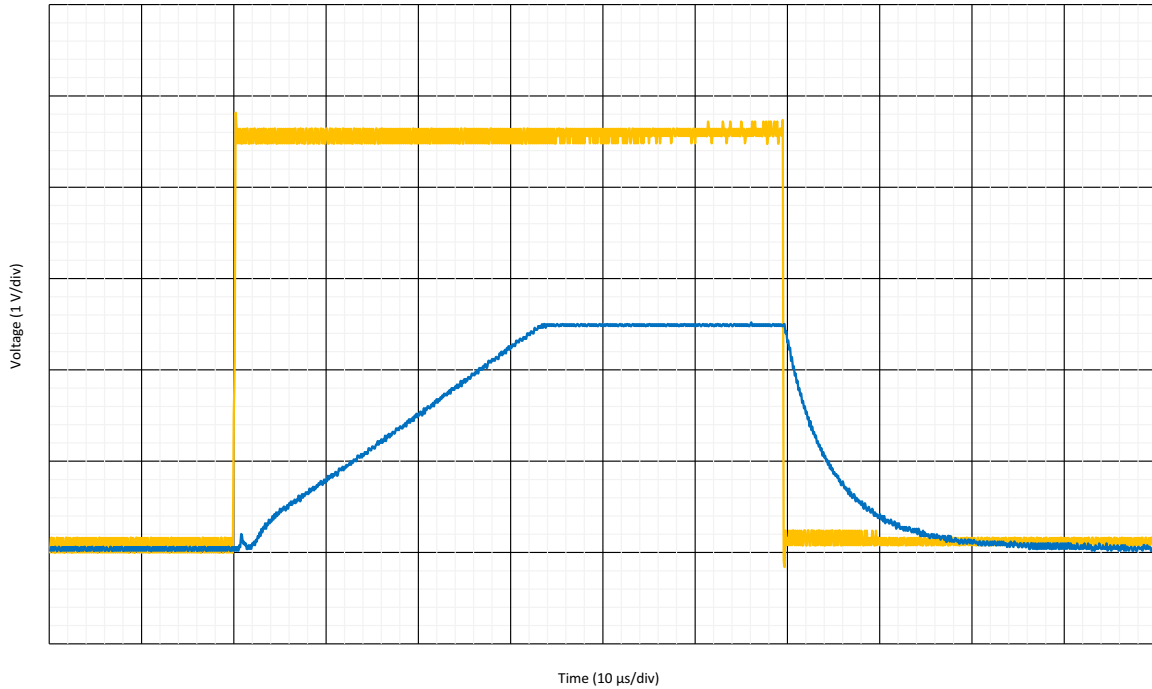

Figure 154: Output Response to Power Down Signal $G = 1 \text{ V/V}$; $R_L = 50 \text{ k}\Omega$; $C_L = 20 \text{ pF}$; $V_{IN} = V_S/2$, $BW = 128 \text{ kHz}$

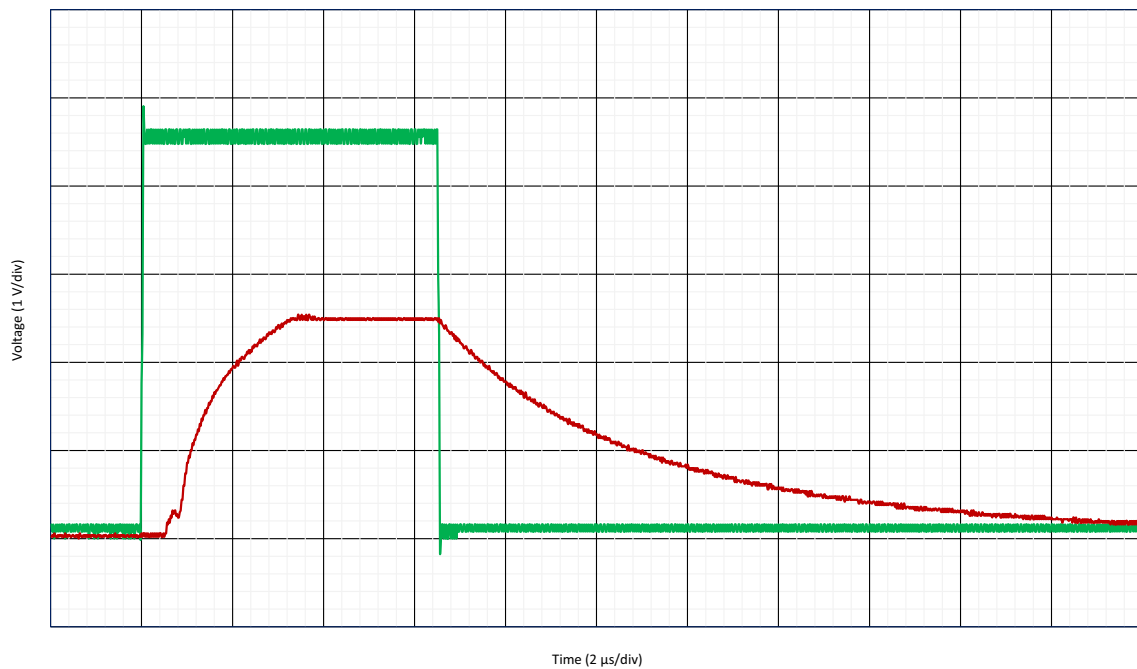

Figure 155: Output Response to Power Down Signal $G = 1 \text{ V/V}$; $R_L = 50 \text{ k}\Omega$; $C_L = 20 \text{ pF}$; $V_{IN} = V_S/2$, $BW = 512 \text{ kHz}$

SLG47004

GreenPAK Programmable Mixed-Signal Matrix
with In-System Programmability and Advanced Analog Features

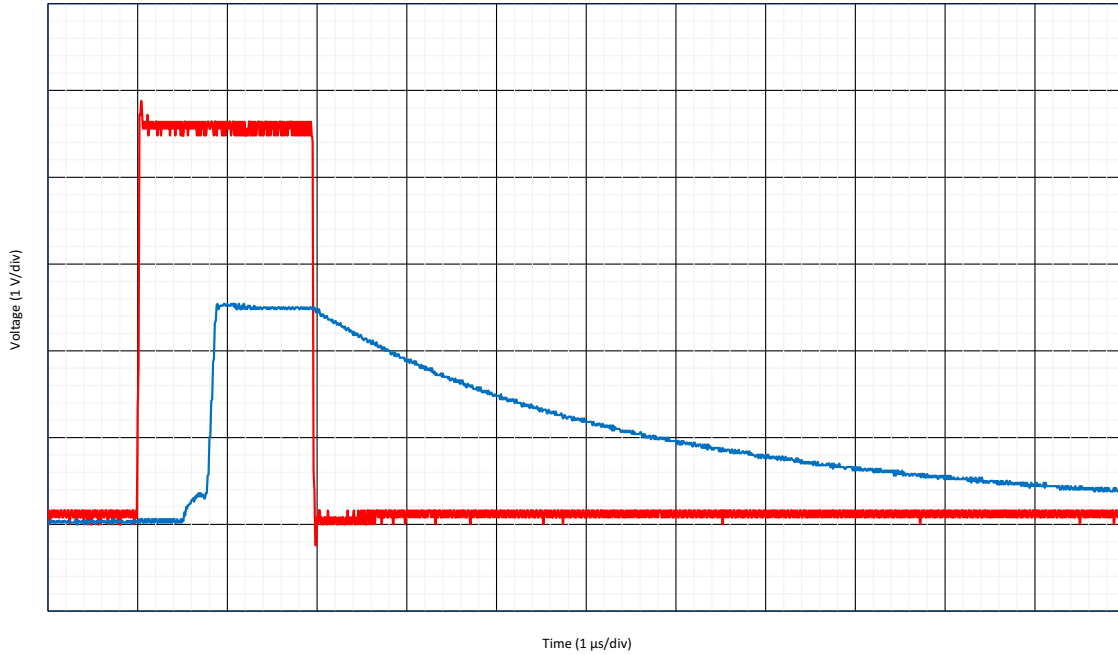

Figure 156: Output Response to Power Down Signal $G = 1 \text{ V/V}$; $R_L = 50 \text{ k}\Omega$; $C_L = 20 \text{ pF}$; $V_{IN} = V_S/2$, $BW = 2 \text{ MHz}$

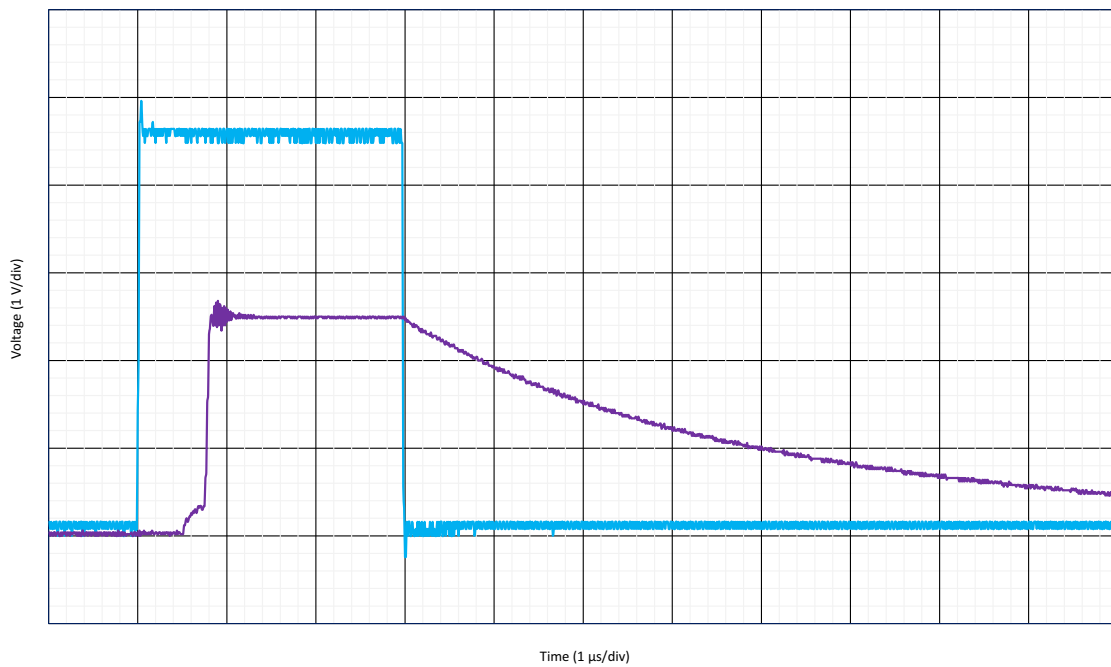

Figure 157: Output Response to Power Down Signal $G = 1 \text{ V/V}$; $R_L = 50 \text{ k}\Omega$; $C_L = 20 \text{ pF}$; $V_{IN} = V_S/2$, $BW = 8 \text{ MHz}$

SLG47004

GreenPAK Programmable Mixed-Signal Matrix
with In-System Programmability and Advanced Analog Features

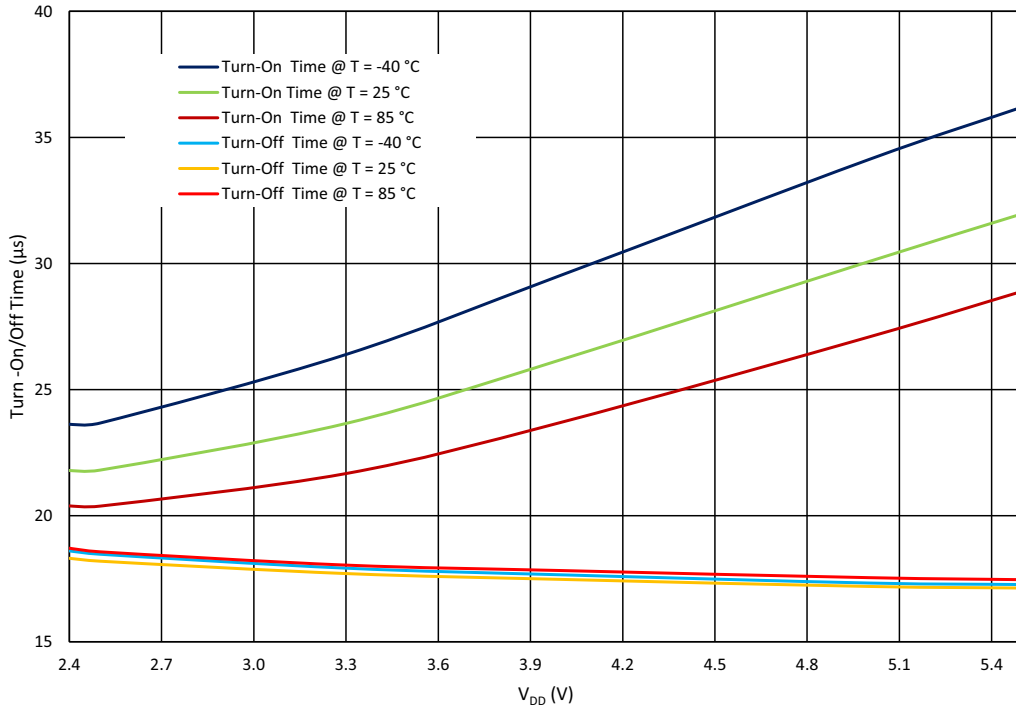

Figure 158: Opampx Turn-On/Off Time vs. V_{DD} at V_{IN} = V_{DD}/2, BW = 128 kHz

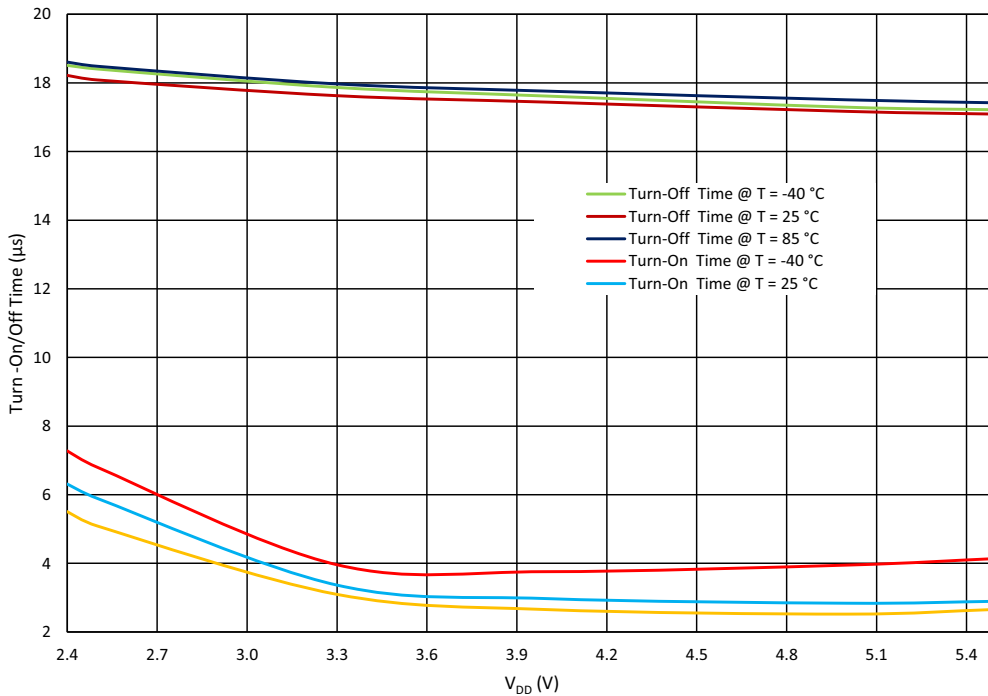

Figure 159: Opampx Turn-On/Off Time vs. V_{DD} at V_{IN} = V_{DD}/2, BW = 512 kHz

SLG47004

GreenPAK Programmable Mixed-Signal Matrix
with In-System Programmability and Advanced Analog Features

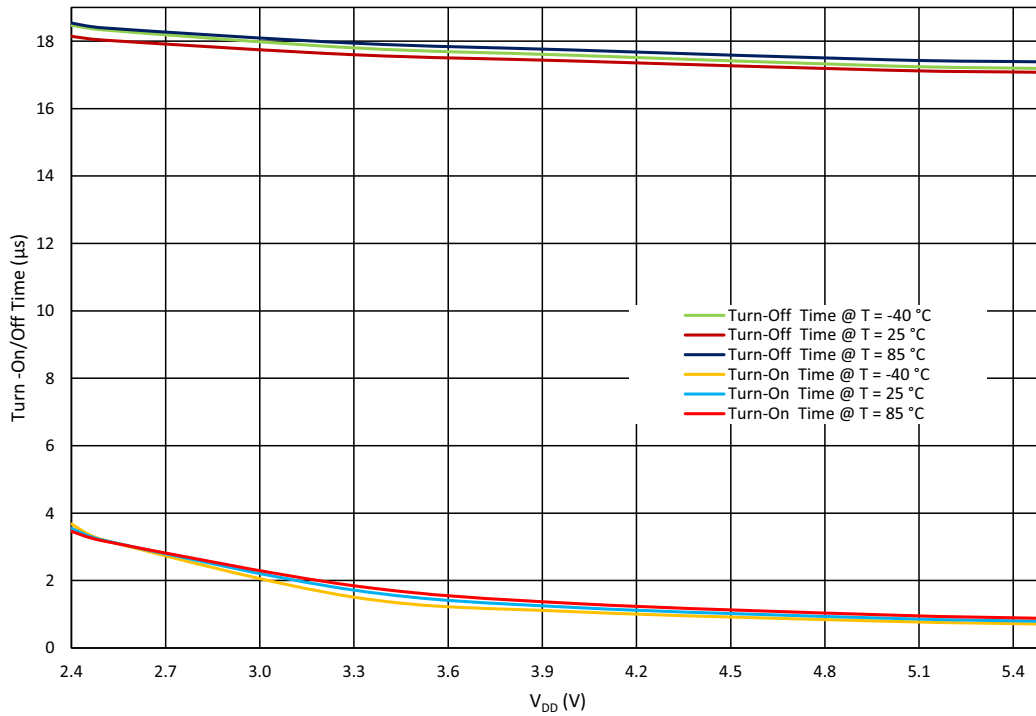

Figure 160: Opampx Turn-On/Off Time vs. V_{DD} at V_{IN} = V_{DD}/2, BW = 2 MHz

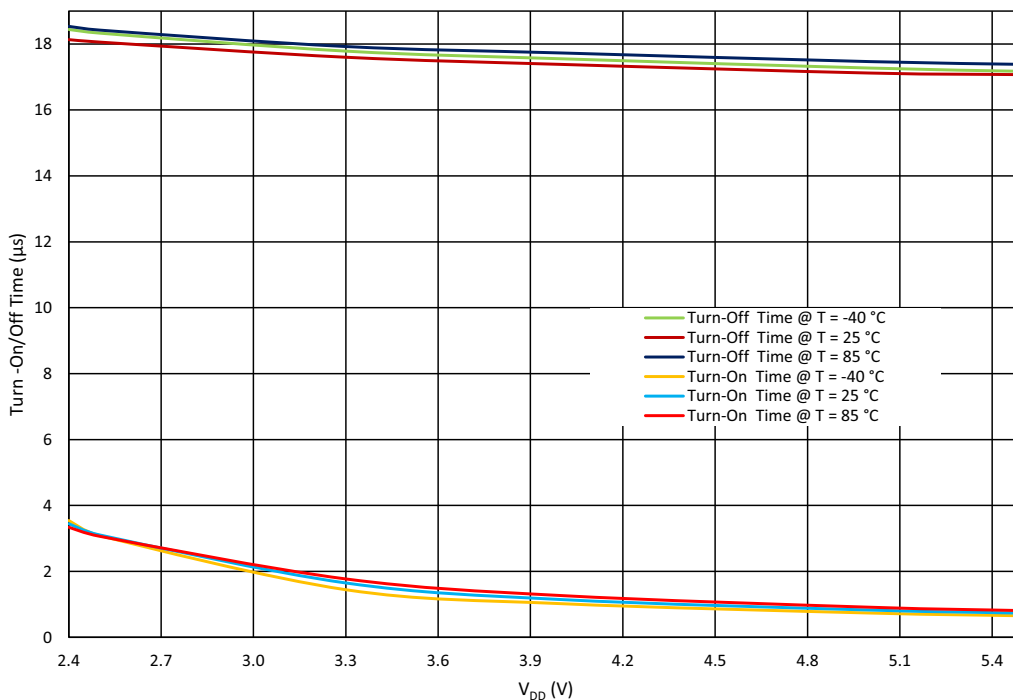

Figure 161: Opampx Turn-On/Off Time vs. V_{DD} at V_{IN} = V_{DD}/2, BW = 8 MHz

SLG47004

GreenPAK Programmable Mixed-Signal Matrix
with In-System Programmability and Advanced Analog Features

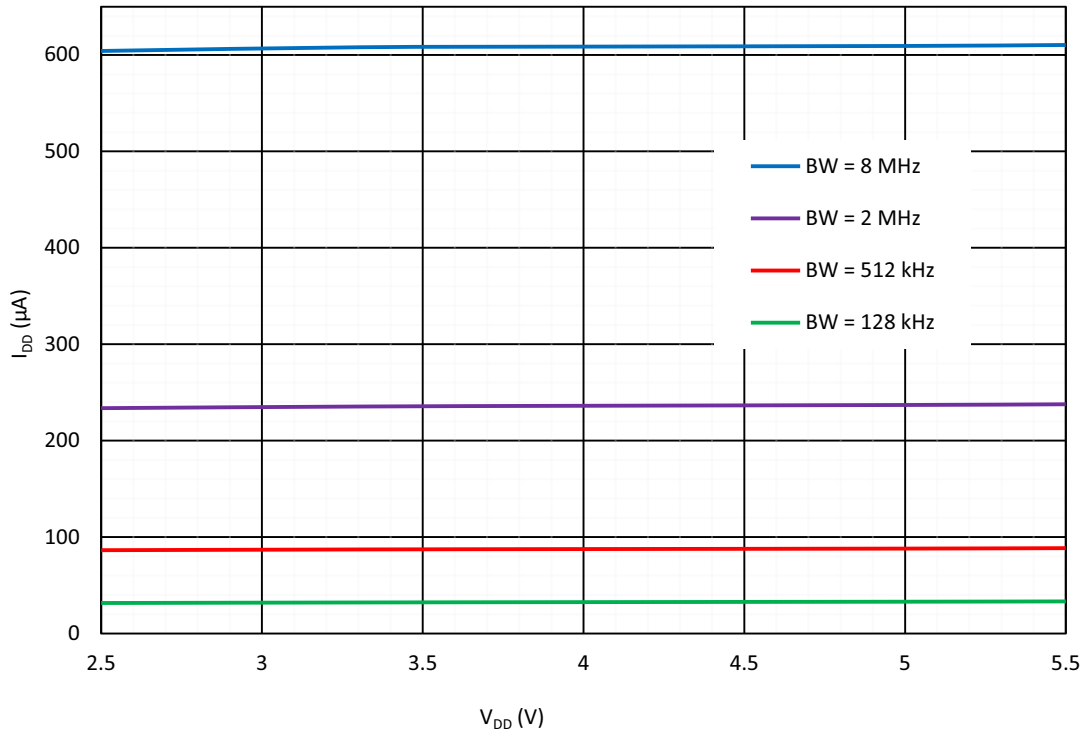

Figure 162: Opamps Quiescent Current Consumption vs. V_{DD}

SLG47004

GreenPAK Programmable Mixed-Signal Matrix with In-System Programmability and Advanced Analog Features

11 Analog Switch Macrocell

11.1 ANALOG SWITCH GENERAL DESCRIPTION

The SLG47004 contains two single-pole/single throw (SPST) normally open analog switches (AS). The structure of the Analog Switches is shown in Figure 163 and Figure 164.

Each analog switch can be controlled from the following sources:

- Connection matrix
- Operational Amplifier macrocell.

Small NMOS (small PMOS) of Analog Switch must be enabled when macrocell is controlled by logic signal from connection matrix. Otherwise, small NMOS (small PMOS) must be disabled when macrocell is controlled by op amp.

Table 56 and Table 57 show possible operation modes of analog switches.

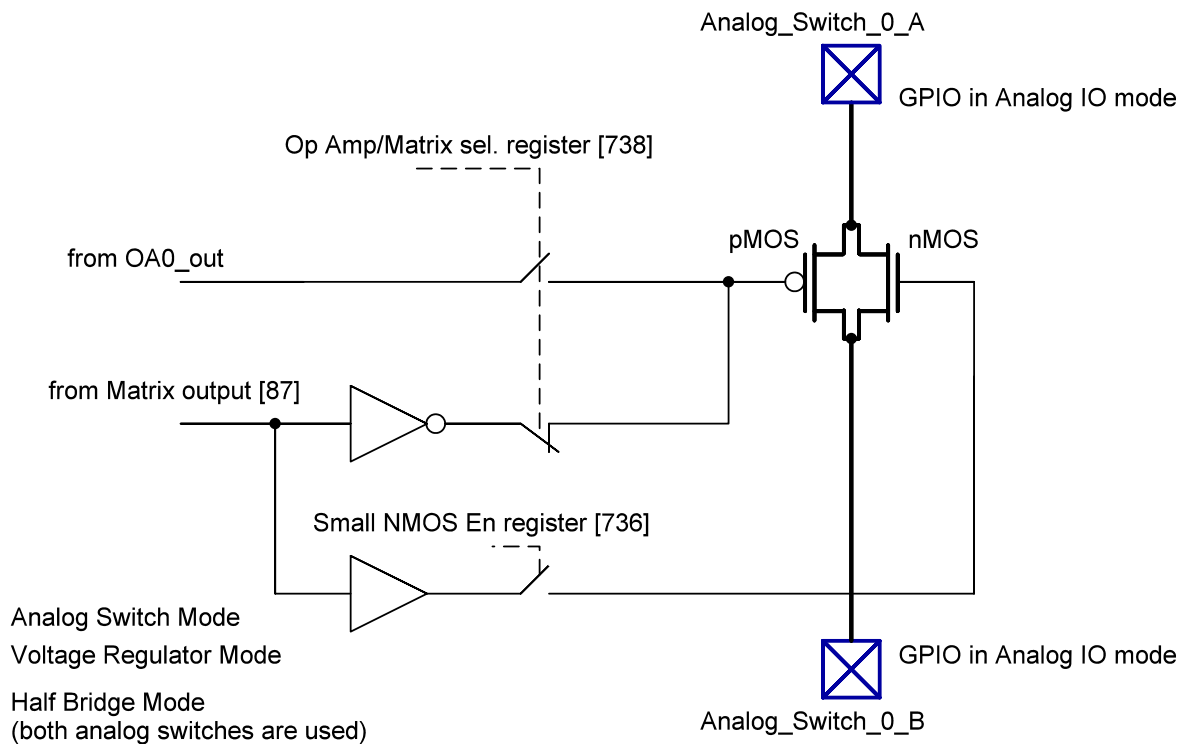

Figure 163: Analog Switch 0 Control Circuit

SLG47004

GreenPAK Programmable Mixed-Signal Matrix with In-System Programmability and Advanced Analog Features

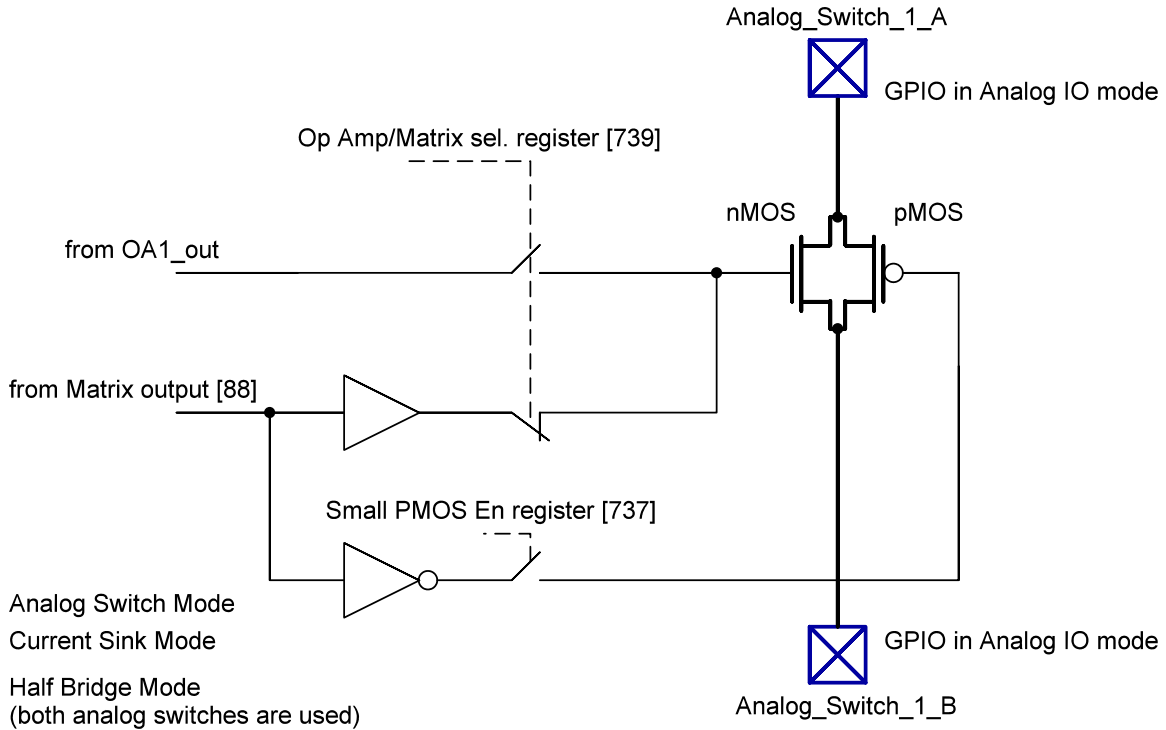

Figure 164: Analog Switch 1 Control Circuit

Table 56: Analog Switch 0 Modes of Operation

Mode of Operation	Half Bridge Mode Enable Register [740]	Matrix/Op Amp Control Register [738]	Small nMOS Enable Register [736]
Analog Switch mode with big pMOS only (control from connection matrix)	0	0	0
Analog Switch mode with all FETs enabled (control from connection matrix)	0	0	1
Voltage Regulator mode	0	1	0
Half Bridge mode with big pMOS only (control from connection matrix)	1	x	0
Half Bridge mode with all FETs enabled (control from connection matrix)	1	x	1

SLG47004

GreenPAK Programmable Mixed-Signal Matrix with In-System Programmability and Advanced Analog Features

Table 57: Analog Switch 1 Modes of Operation

Mode of Operation	Half Bridge Mode Enable Register [740]	Matrix/Op Amp Control Register [739]	Small pMOS Enable Register [737]
Analog Switch mode with big nMOS only (control from connection matrix)	0	0	0
Analog Switch mode with all FETs enabled (control from connection matrix)	0	0	1
Current Sink mode	0	1	0
Half Bridge mode with big nMOS only (control from connection matrix)	1	x	0
Half Bridge mode with all FETs enabled (control from connection matrix)	1	x	1

11.2 HALF BRIDGE MODE

Two switches can be externally connected in series to create a half bridge. Please refer to tables [Table 56](#) and [Table 57](#) to enable half bridge mode. Additional logic will be connected to the analog switches to simplify control. [Figure 165](#) shows the half bridge structure with two analog switches.

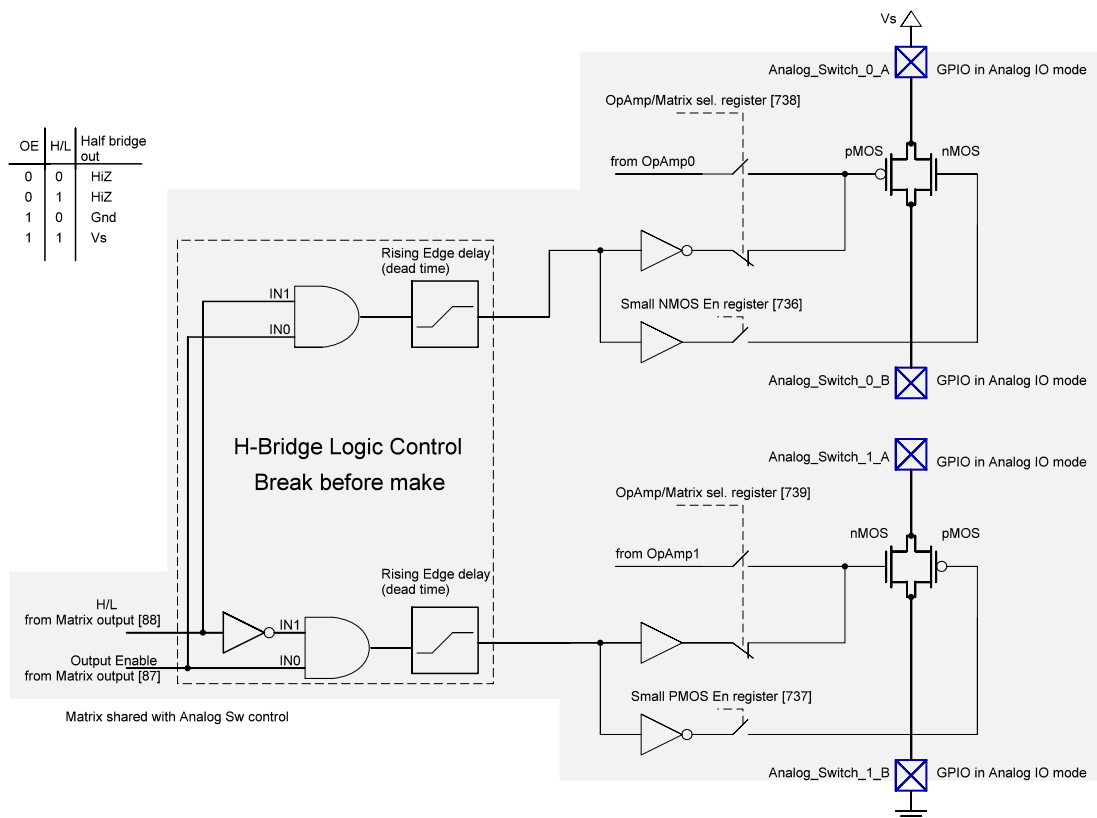

Figure 165: Structure of Half Bridge

SLG47004

GreenPAK Programmable Mixed-Signal Matrix with In-System Programmability and Advanced Analog Features

11.3 ANALOG SWITCHES TYPICAL PERFORMANCE

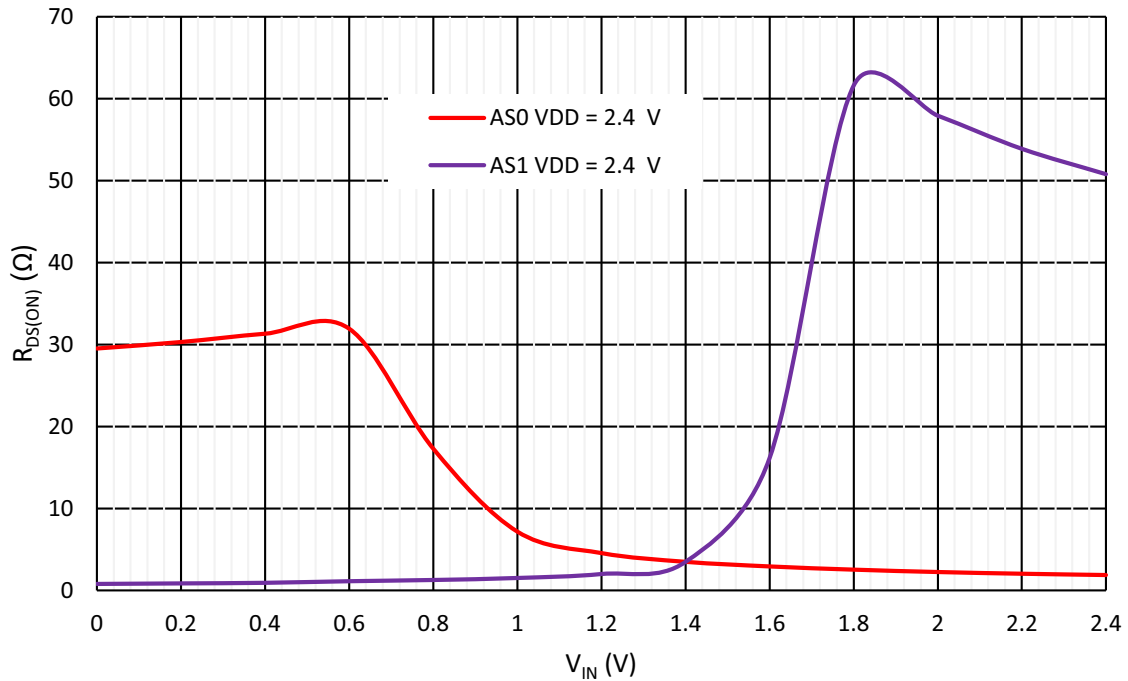

Figure 166: Typical R_{ON} vs. Input Voltage (V_i) for $V_i = 0$ to V_{DDA} , $I_{LOAD} = 1$ mA, $V_{DDA} = 2.4$ V

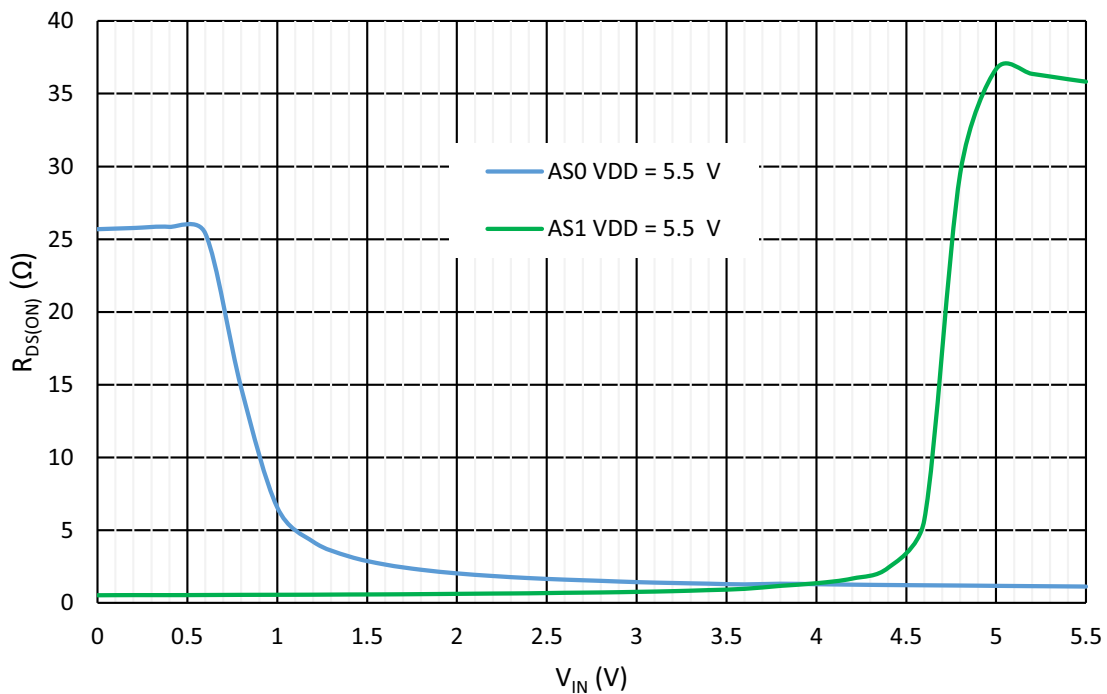

Figure 167: Typical R_{ON} vs. Input Voltage (V_i) for $V_i = 0$ to V_{DDA} , $I_{LOAD} = 1$ mA, $V_{DDA} = 5.5$ V

SLG47004

GreenPAK Programmable Mixed-Signal Matrix
with In-System Programmability and Advanced Analog Features

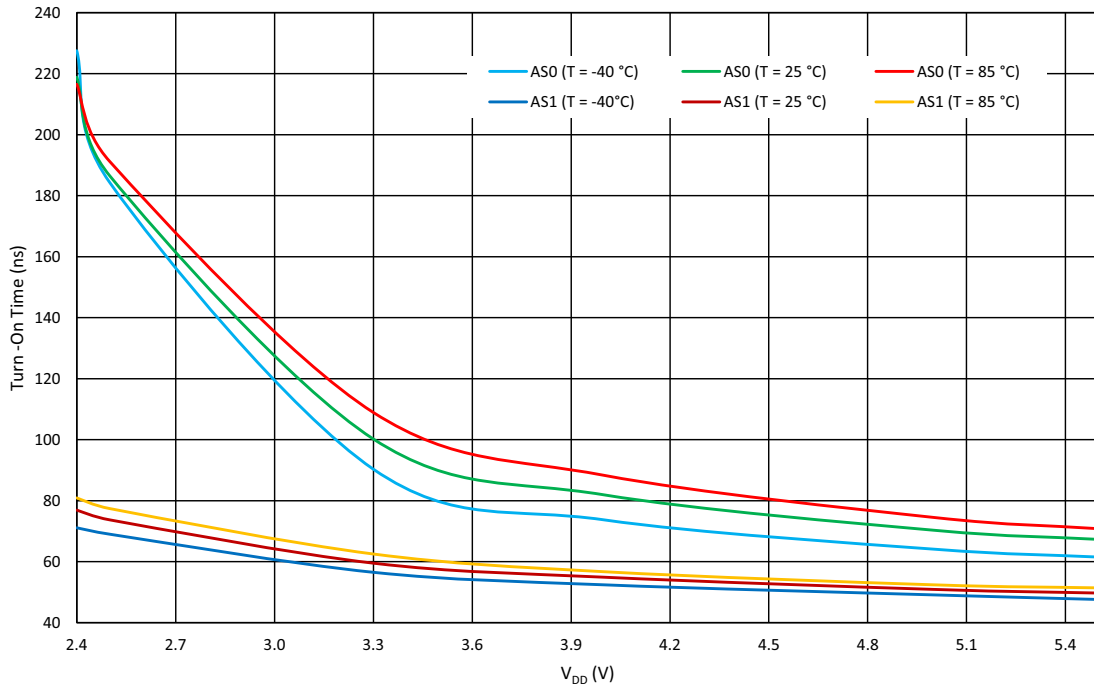

Figure 168: Turn-On Time vs. V_{DD} at R_{LOAD} = 100 Ω to GND, V_{IN} = V_{DD}/2

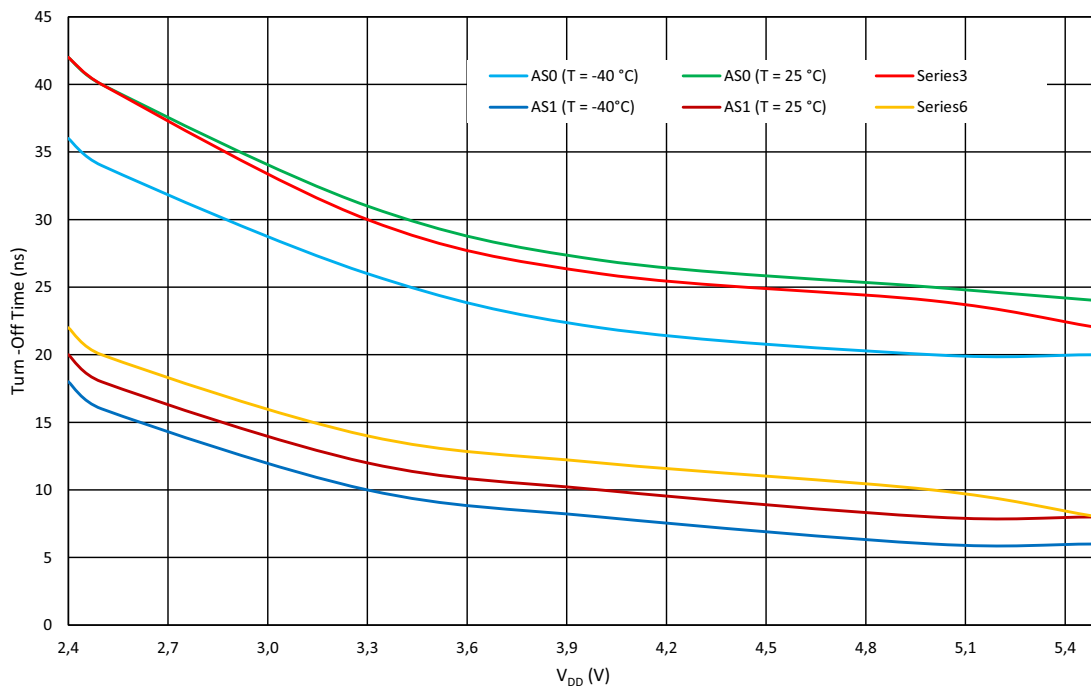

Figure 169: Turn-Off Time vs. V_{DD} at R_{LOAD} = 100 Ω to GND, V_{IN} = V_{DD}/2

12 Digital Rheostats and Programmable Trim Block

The SLG47004 contains two 10-bit Digital Rheostats. The structure of both macrocells is shown in [Figure 170](#). The range of digital code that corresponds to the rheostat resistance ranges from 0 to 1023 (1024 taps). Code 0 corresponds to the minimum resistance between the RHx_A and RHx_B terminals. As the code value increases, the resistance between the RHx_A and RHx_B terminals monotonically increases. Consequently, when the code value decreases, the resistance between the RH0_A and RH0_B terminals decreases as well (see [Section 12.2](#)). The voltage on any rheostat pin can be in the range from AGND to V_{DDA} , as well as be dynamically changed during operation.

To guarantee proper operation of digital rheostats charge pump must be turned on (matrix input [86] must be logic High or registers [912] = 1, [913] = 1). Optionally user can turn off rheostats charge pump to decrease energy consumption. But it's strongly recommended to use the charge pump if $V_{DD} < 4.5$ V.

The rheostat resistance can be changed in three ways:

- Changing the Rheostat value using the I²C interface;
- Manually changing the rheostat value using clock and up/down signals, similar to the counter;
- Using the Built-in Auto-Trim mode, where the rheostat value change is done using a special logic based on the signal from the Chopper ACMP.

Each rheostat also has three Switching Speed Modes:

- Regular mode (Register [915] = 0, Register [914] = 0) - up to 1 kHz. In this mode, Low Power Bandgap Chopper Oscillator that oscillates around 120 kHz is used as a source for the charge pump clock. This setting has a lower quiescent current at the expense of a longer recovery time after input voltage spikes.
- Fast mode (Register [915] = 0, Register [914] = 1) - up to 100 kHz. In this mode, the 2 MHz OSC is used as a source for the charge pump clock. This setting has a faster recovery time for input voltage spikes at the expense of a larger quiescent current. Please note that this selection forces On the OSC1 (2.048 MHz).
- Auto Selection (Register [915] = 1, Register [914] = either) when trim is used. When Auto-Trim is active, the fast mode is used. After the Auto-Trim process completes, the regular mode is used.

Note: The maximum switching speed can be achieved if no external capacitive load is connected to the rheostat terminals.

The Programmable Trim (PT) blocks of rheostats macrocell contain analog MUXs, digital MUXs, Chopper ACMP, and additional logic. The two analog MUXs (M1 and M2) and the Chopper ACMP are both shared between the two rheostats. All analog and digital MUXs are set by NVM bits and can be overwritten with I²C.

The M_CK0 and M_CK1 MUXs select the clock source from internal pre-dividers of the internal oscillators or from the connection matrix. The internal clock sources for the rheostats are OSC0, OSC0/8, OSC0/64, OSC0/512, OSC0/4096, OSC0/32768, OSC0/262144, OSC1, OSC1/8, OSC1/64, and OSC1/512. The PT blocks of the rheostat use the same clock scheme as Counter/Delay Macrocells (refer to [16.5](#)). M_CH0 and M_CH1 select the Chopper comparator or a matrix output as the signal source for the main rheostat up/down counter direction. The output of the Chopper ACMP is connected with the Up/Down inputs of the PT blocks by default. The output of the Chopper ACMP can be optionally inverted by setting register [882] to "1".

M1 MUX selects the input for the Chopper comparator to be connected either internally to one of 3 integrated op amps (Op Amp0 out, Op Amp1 out, In Amp Out) or externally to a PIN. M2 MUX is simplified symbol of Chopper ACMP reference selection blocks. The Chopper ACMP reference ("-") input can be: analog signal from pin, divided internal Vref voltage (6-bit divider), or divide V_{DDA} voltage (6-bit divider). In Auto-Trim mode each of Rheostats has it own settings for Chopper ACMP inputs. For more information about Chopper ACMP Vref see [Section 9.2](#).

The power-up signal for the Chopper ACMP can be handled either by matrix output signal or Set0/Set1 signal from the PT macrocell. In Auto-Trim mode (Auto_Cal_Dis_RHx NVM bit = 0) additional internal logic enables the clocking of the corresponding PT macrocell counter and disables clocking when one of the stop conditions is reached. See a detailed description in [Section 12.4](#). In [Figure 170](#) when Auto_Cal_Dis_RHx NVM bit = 0 (Auto-Trim mode is enabled), the clocking pulses for the internal PT macrocell counter are under control of additional logic. When Auto_Cal_Dis_RHx NVM bit = 1 (Auto-Trim mode is disabled), all additional logics (Set signal, internal Set signal, Idle/Active signal) operate the same way, but clock pulses are always enabled and generated externally by the user. Calibration channel can be selected automatically (1st channel is channel 0, second channel is channel 1) or can be set manually by registers [893:892].

The inputs of Chopper ACMP can be reconfigured while operating in Auto-Trim mode. There is one configuration of inputs (M1, M2 configuration, [Figure 170](#)) for the case when Set0 signal is latched, and another configuration of M1, M2 MUXs when Set1 signal is latched. For example, M1 MUX can be configured to operate with In Amp out when Set0 is latched and Chopper_ACMP+ pin when Set1 is latched. The same way, M2 can be configured to work with any of M2 inputs when Set0 or Set1 are latched. Note that the default configuration is the configuration for Set0 signal. When Chopper ACMP operates as separate ACMP and Auto-Trim function is disabled, M1 and M2 MUXs operates with configuration for Set0 signal.

SLG47004

GreenPAK Programmable Mixed-Signal Matrix with In-System Programmability and Advanced Analog Features

Keep in mind that two Auto-Trim processes cannot be done simultaneously. When the Auto-Trim process for one rheostat is active, all signals on the Set input for another rheostat will be ignored. See a detailed description in [12.4.1](#). The initial user defined value of Digital Rheostat resistance can be programmed into the NVM. The initial value will be loaded during the Power-On event and this value will be used as the initial rheostat resistance, as well as a starting point for count down or count up.

Both read and write operations are allowed for rheostat resistance value, stored in NVM. Also, both read and write operations are allowed for current rheostat resistance value. RH0 read operation - registers [1561:1552], write operation - registers [1545:1536]. RH1 read operation - registers [1689:1680], write operation - registers [1673:1664].

SLG47004

GreenPAK Programmable Mixed-Signal Matrix with In-System Programmability and Advanced Analog Features

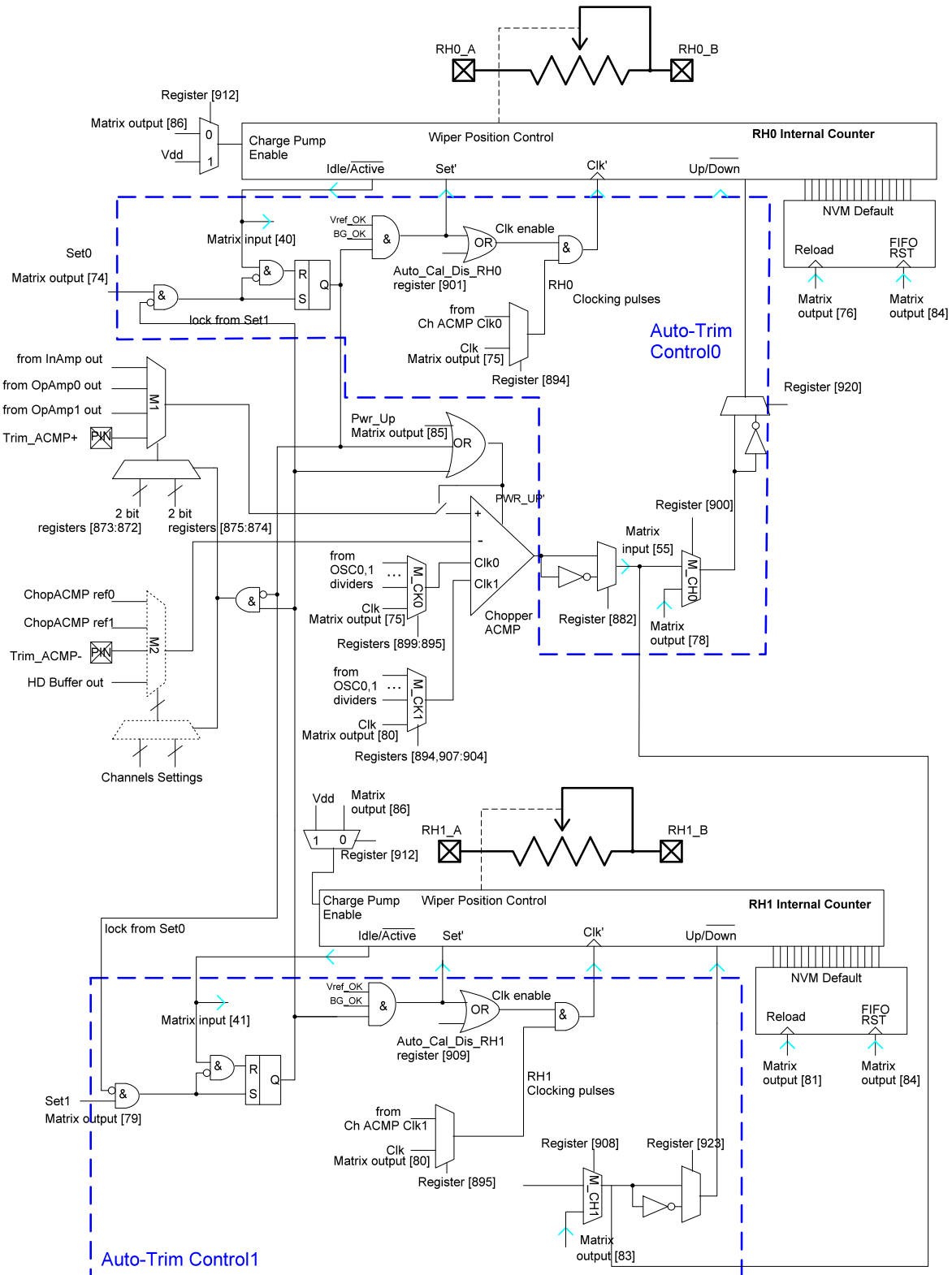

Figure 170: Programmable Trim Blocks and Digital Rheostat's Internal Circuit

SLG47004

GreenPAK Programmable Mixed-Signal Matrix with In-System Programmability and Advanced Analog Features

PT macrocell signals:

- “Set”: external Set signal begins the Auto-Trim process when Auto_Cal_Dis_RHx bit is cleared (registers [901]). Otherwise, this signal has no effect. The behavior of the PT macrocell in Auto-Trim mode is described below.
- “Reload”: when Reload goes high the rheostat value stored in the MTP NVM will be loaded into the rheostat (Register and Counter) overwriting any current setting. This signal is edge sensitive. It has no effect while the Auto-Trim procedure is active. For detailed information see Section 12.3.
- “Program”: when Program goes high the Internal Counter value of the rheostat will be programmed into the MTP overwriting any current value in the NVM. This procedure can be done up to 1000 times. This signal is also edge sensitive. It has no effect while the Auto-Trim procedure is active. For detailed information see 12.3. To enable "Program" signal from connection matrix RH_PRB register must be cleared (RH_PRB [1796] = 0). If RH_PRB [1796] register is set to 1, the access to NVM is disabled for "Program" signal. Refer to Section 19.6 for more details.
- “Clock”: this input has the following options: the PT macrocell can be clocked internally or from matrix. When clocked internally, the clock is automatically enabled/disabled by the Set input logic in Auto-Trim mode. The internal clock is synchronized with the Chopper ACMP clock.
- “Up/Down”: the rheostat counter counts up when the signal is High and down when the signal is Low.
- “Idle/Active”: this is the connection matrix input, that is logic HIGH by default. It goes LOW with rising edge on SET input if Auto-Trim mode is enabled (Auto_Cal_Dis_RHx NVM bit = 0). After the end of Auto-Trim procedure (one of stop conditions occurs) this signal sets to logic HIGH again.
- “FIFO nReset”: low level at this input clears internal FIFO buffer for commands Reload and Program for both rheostats. User should provide high logic level at this input for the normal rheostat operation.

There is also an overflow protection option, for which the counter will stop counting up when the maximum value (0x3FF) is reached or stop counting down when the minimum value (0x00) is reached. The digital rheostat is initialized/powered in the first place. The rheostat value is Hi-Z (or highest resistance if it is impossible to disconnect the rheostat) during the Power-On sequence.

12.1 POTENTIOMETER MODE

This mode allows two 2-pin rheostats to work as one 3-pin potentiometer. When this mode is active (register [917] = 1), user changes the value of RH0 internal counter. In this mode, the value of RH1 counter is the inverted value of RH0 counter (Figure 171). Note that the RH0_B pin and the RH1_A pin must be connected externally. Also, note that the Auto-Trim function isn't allowed in Potentiometer Mode.

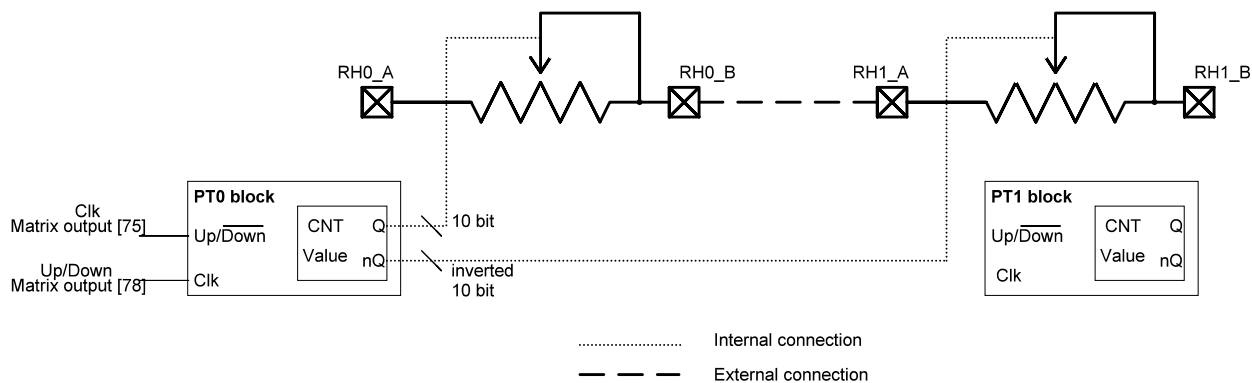
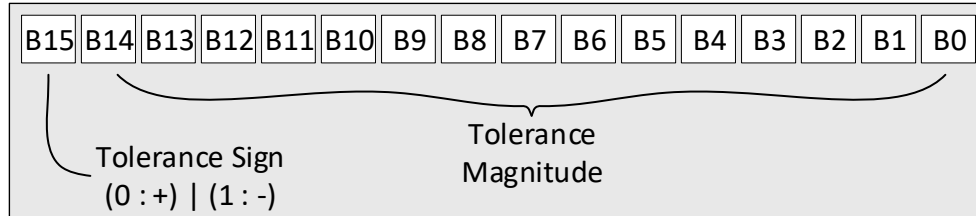

Figure 171: Rheostats in Potentiometer Mode

12.2 CALCULATING ACTUAL RESISTANCE

In applications where the absolute rheostat resistance is critical, the user can calculate it using the rheostat tolerance data, the minimum rheostat resistance, and the desired code.

The 16-bit tolerance data for both rheostats has been programmed into registers 0xE6 to 0xE9. These registers can be used to calculate the total rheostat resistance. The 16th bit defines the sign (0 = +, 1 = -) of the tolerance. The other fifteen bits correspond to the absolute value of the rheostat tolerances variation from 100 kΩ measured at 25 °C.

Figure 172: Rheostat Tolerance Registers

Note that the rheostat tolerance data is programmed into registers 0xE6 to 0xE9. To avoid losing this tolerance data, special attention must be paid when erasing and reprogramming page 14 in the NVM.

The rheostat value at a given code depends on the total digital rheostat resistance. The equations below can be used to calculate the rheostat resistance.

$$R_{Code} = (R_{DR} - R_{DR\ MIN}) \times (code/1023) + R_{DR\ MIN}$$

$$R_{DR} = 100 \times 10^3 + (sign_{RH_Tolerance} \times R_{RH_Tolerance})$$

where:

R_{Code} - Rheostat Resistance at a Given Code;

R_{DR} - Total Digital Rheostat Resistance;

$R_{DR\ MIN}$ - Minimum Rheostat Resistance;

$code$ - Rheostat Position Ranging from 0x000 to 0x3FF;

$sign_{RH_Tolerance}$ - the MSB of the Rheostat's Tolerance Data;

$R_{RH_Tolerance}$ - the 15 LSBs of the Rheostat's Tolerance Data.

For example, let's say that 0x2B67 has been written into the rheostat tolerance registers within the GreenPAK's NVM. B15 corresponds to a positive sign while B14:0 translates into a decimal value of 11111. R_{DR} calculates to approximately 111,111 Ω and can be used with the minimum rheostat resistance to calculate the resistance at a given code. Note that the minimum rheostat resistance must be measured to obtain precise results, but a range is provided in [Table 24](#).

12.3 DIGITAL RHEOSTAT VALUE SELF-PROGRAMMING INTO THE NVM

The current value of rheostat is stored in the Internal Counter. This value can be programmed into the MTP by setting logic HIGH at "Program" input. In this case, SLG47004 will generate a specific memory control sequence to rewrite a new value into the NVM. There is a separate NVM page that is dedicated for the Digital Rheostat value.

There is a dedicated bit RH_PRB, that enables/disables "Program" signal of PT block to change NVM rheostats resistance values. If RH_PRB[1796] = 0, "Program" signal is enabled. If RH_PRB[1796] = 1, "Program" signal is disabled. Note that RH_PRB bit has no effect on I²C access to NVM. To enable/disable I²C access to rheostat resistance value, stored in NVM, user must change NPRB0, NPRB1 bits. Refer to [Section 18.5](#).

SLG47004 can latch up to four "Program" and "Reload" signals of RH0 and RH1 (Reload RH0, Program RH0, Reload RH1, Program RH1). The same signal can't be latched second time, until it is processed. All latched signals will be processed in the order of arrival (FIFO buffer), since only one signal can access NVM at the same time. If Auto-Trim process of RH0 or RH1 is active and one or more "Reload", "Program" signals for corresponding rheostat come, SLG47004 will wait until the end of Auto-Trim process and then process will latch "Reload", "Program" signals. Set0 or Set1 signal can be latched at any time and processed when rheostat clocking isn't disabled by "Program" or "Reload" signals.

User can clear the FIFO buffer by setting low logic level at FIFO nReset input of PT blocks.

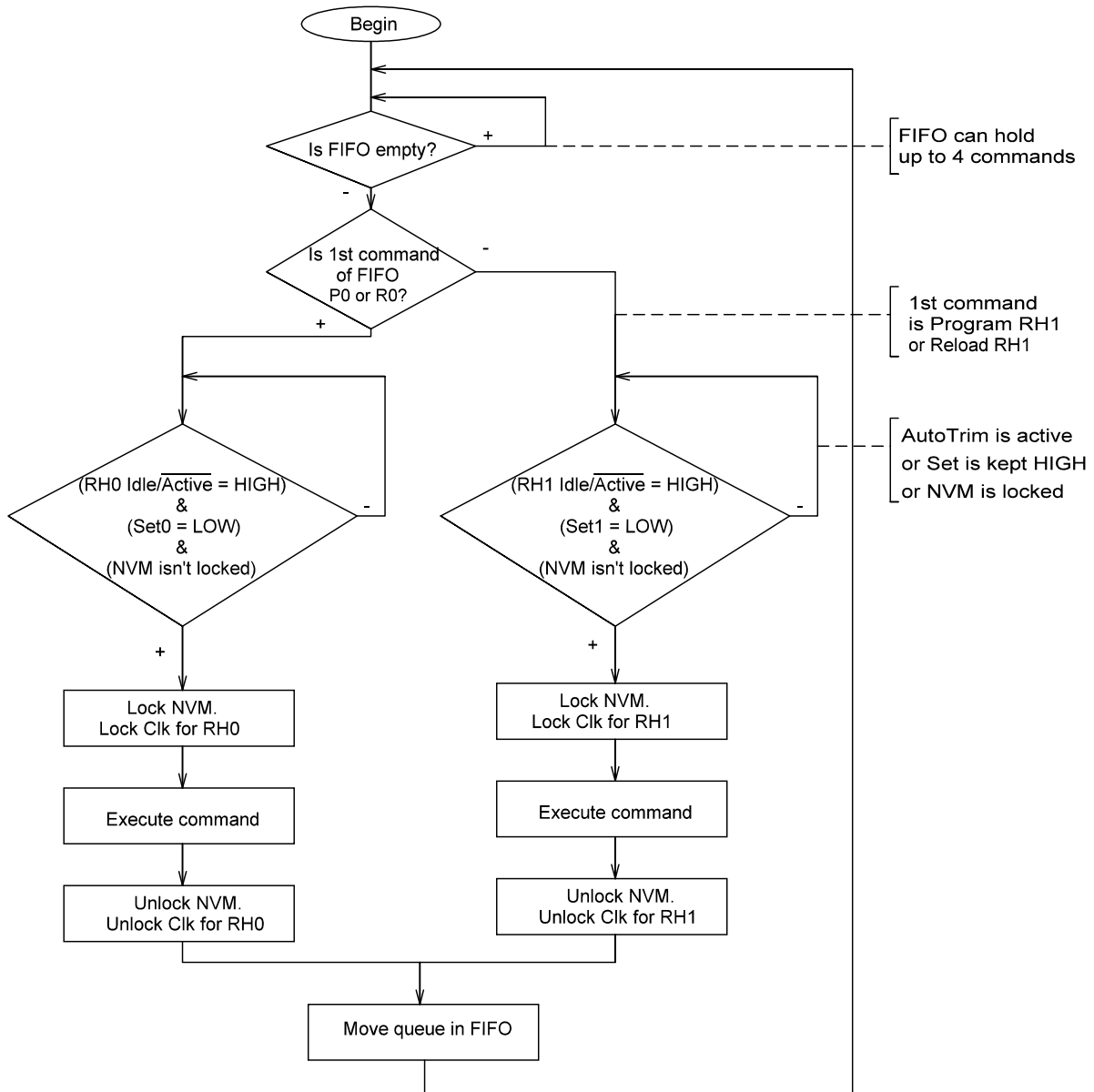

Figure 173: Flowchart of "Program" and "Reload" Signals

SLG47004

GreenPAK Programmable Mixed-Signal Matrix
with In-System Programmability and Advanced Analog Features

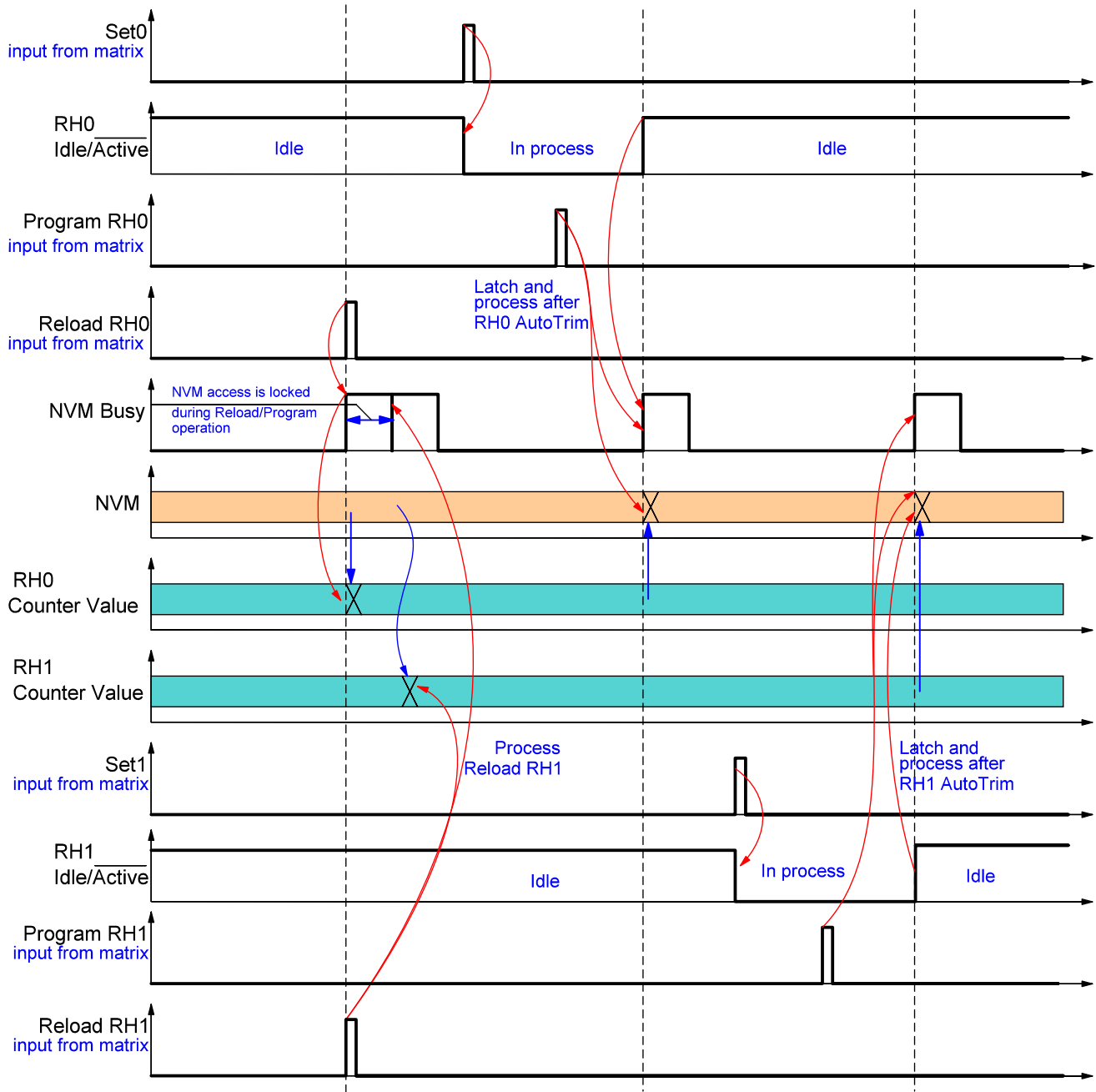

Figure 174: Example of Latching and Processing "Program" and "Reload" Signals

Since the access to the MTP NVM is disabled during NVM self-programming procedure, the device will not acknowledge it via I²C interface. This can be used to determine when the erase/programming cycle is completed (this feature can be used to maximize bus throughput). ACK polling can be used in this case.

If the device is still busy during the write cycle, then no ACK will be returned. If no ACK is returned, then the Start bit and control byte must be re-sent. Once the cycle is complete, then the device will return the ACK and the master can proceed with the next Read or Write command.

12.4 TRIMMING PROCESS USING PROGRAMMABLE TRIM BLOCK

There are several ways of implementing the trimming process using the PT block. One of the essential features of the PT macrocell is the Auto-Trim function described below. It allows the user to design simple calibration circuits for a wide variety of applications.

12.4.1 Trimming Process with Auto-Trim Option Enabled

For using the Auto-Trim function the following preliminary steps must be taken:

- Clear Auto_Cal_Dis_RHx NVM bit (0 is default value). This enables Auto-Trim function.
- Configure M1 MUX (registers [875:872]). It can be user system voltage feedback. If Auto-Trim function is used for two rheostats, M1 MUX must be configured for both rheostats (for cases when Set0 is latched and when Set1 is latched).
- Configure M2 MUX. It can be user desired set point threshold. If Auto-Trim function is used for two rheostats, M2 MUX must be configured for both rheostats (for cases when Set0 is latched and when Set1 is latched). Remember, that M2 MUX is simplified symbol of Chopper ACMP reference selection blocks.
- Configure M_CH0 (M_CH1) MUX to work with Chopper ACMP (M_CH0,1 MUXs are configured to work with Chop ACMP by default).
- Configure inverting or non-inverting Chopper ACMP output (registers [923], [920] and [882]);
- Select clock source (internal clock from internal pre-dividers or from connection matrix). Note that in Auto-Trim mode clock source frequency for the PT Block is limited by the Chopper Comparator time response. Therefore, the clock source frequency must not be greater than $\langle f_{ChACMP} \rangle$ kHz.
- Start the Auto-Trim process by setting the Set0 (Set1) input of PT block to a High level. The Auto-Trim process stops if one of three stop conditions occur:
 - 1) 2nd time change on Up/Down input at the moment of rising edge on Clock input (see [Figure 175](#)).
 - 2) the value of rheostat reaches its maximum (1023).
 - 3) the value of rheostat reaches its minimum (0).

Stop conditions result in a change of the Idle/Active signal, which resets the internal Auto-Trim logic.

Note that the Set input is edge sensitive, but if the user keeps a High logic level at this input after reaching the set point, the PT block will continue to operate and continue to switch rheostat around the set point.
- To start new Auto-Trim process user should reapply a High level on Set input.

The detailed flow of Auto-Trim process is shown in [Figure 175](#), [Figure 176](#), [Figure 177](#).

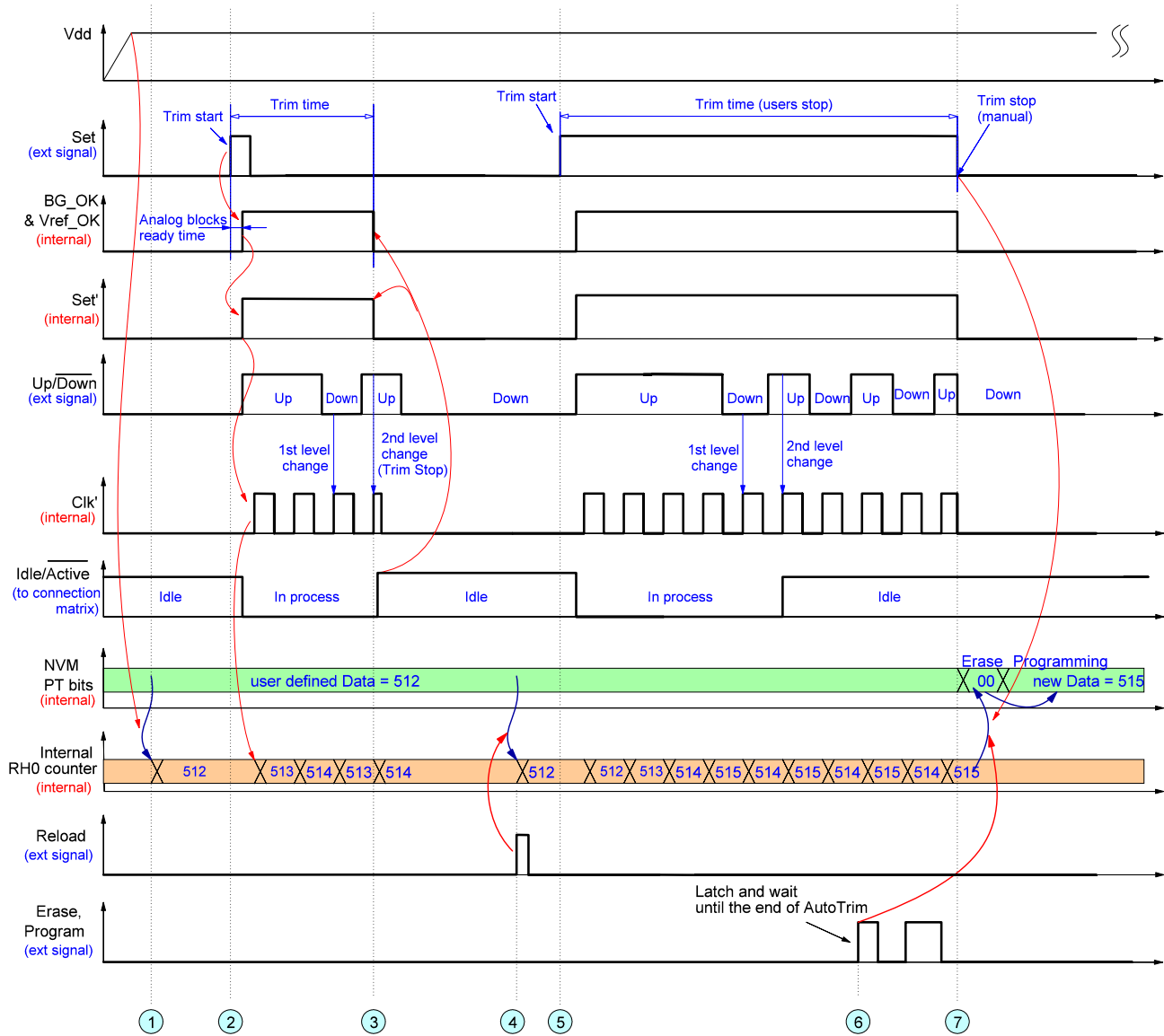

Figure 175: Example of Auto-Trim Process for a Single Rheostat

The key events of the Auto-Trim process are the following (see [Figure 175](#)):

1. During the startup event the SLG47004 loads the rheostat value from NVM to Internal Counter. In this example this value is 512.
2. The Trim process starts with a rising edge on Set input. This Set signal is latched until the end of the Auto-Trim process. The Set signal will enable the Chopper ACMP and the Vref, if they were not enabled earlier. After a ready signal from analog blocks (BG_OK & Vref_OK), the clock pulses for the internal counter are enabled. The counter starts to count up or down depending on the level at the Up/Down input. If user selected the "Internal Clock" option for Clock input, these clock pulses are generated automatically during trim time. Each rising edge of the Clock pulse changes the value of the counter and, consequently, the value of the rheostat.
3. There are three stop conditions for the Auto-Trim process:
 - 1) A subsequent change on Up/Down input at the moment of rising edge on Clock input.

SLG47004

GreenPAK Programmable Mixed-Signal Matrix with In-System Programmability and Advanced Analog Features

- 2) The value of the rheostat reaches its maximum (1023).
- 3) The value of the rheostat reaches its minimum (0).

If the Set input signal is shorter than the trim time, the Auto-Trim process stops automatically after a stop condition occurs (event 3, [Figure 175](#)). However, if a stop condition comes and High logic level holds on the Set input, the rheostat value will be switched near the set point until a Low level on the Set input occurs (event 7, [Figure 175](#)). Note that the Idle/Active signal changes its level to High (Auto-Trim is done) even if the user keeps a High logic level at the Set input.

After the end of the Auto-Trim process, Chopper ACMP powers down and its output goes to a Low logic level.

4. After a rising edge at the “Reload” signal, the value from NVM is copied to the rheostat Internal Counter overwriting current rheostat settings.
5. During this event user starts Auto-Trim process, but holds High logic level at Set input for a time longer than Auto-Trim process.
6. A “Program” signal comes. The “Program” command is latched and will be executed at the end of the Auto-Trim process.
7. The Auto-Trim process stops when the signal at the Set input goes to Low level. Note that a logic High level at the Set input was held longer than the time that was needed for the Auto-Trim process. At the end of the Auto-Trim process, the SLG47004 starts the NVM self-programming routine to copy the rheostat value from Reg LATCH to MPT NVM.

[Figure 176](#) shows a similar Auto-Trim example. The only difference is that the user defined clock source as “External clock” from connection matrix. The clock pulses are present at the Clock input all the time, but have effect (rheostat value changes) during Trim time only. The stop condition for this case is the following: PT block reaches boundary value of 1023 and the logic level at change Set input is Low.

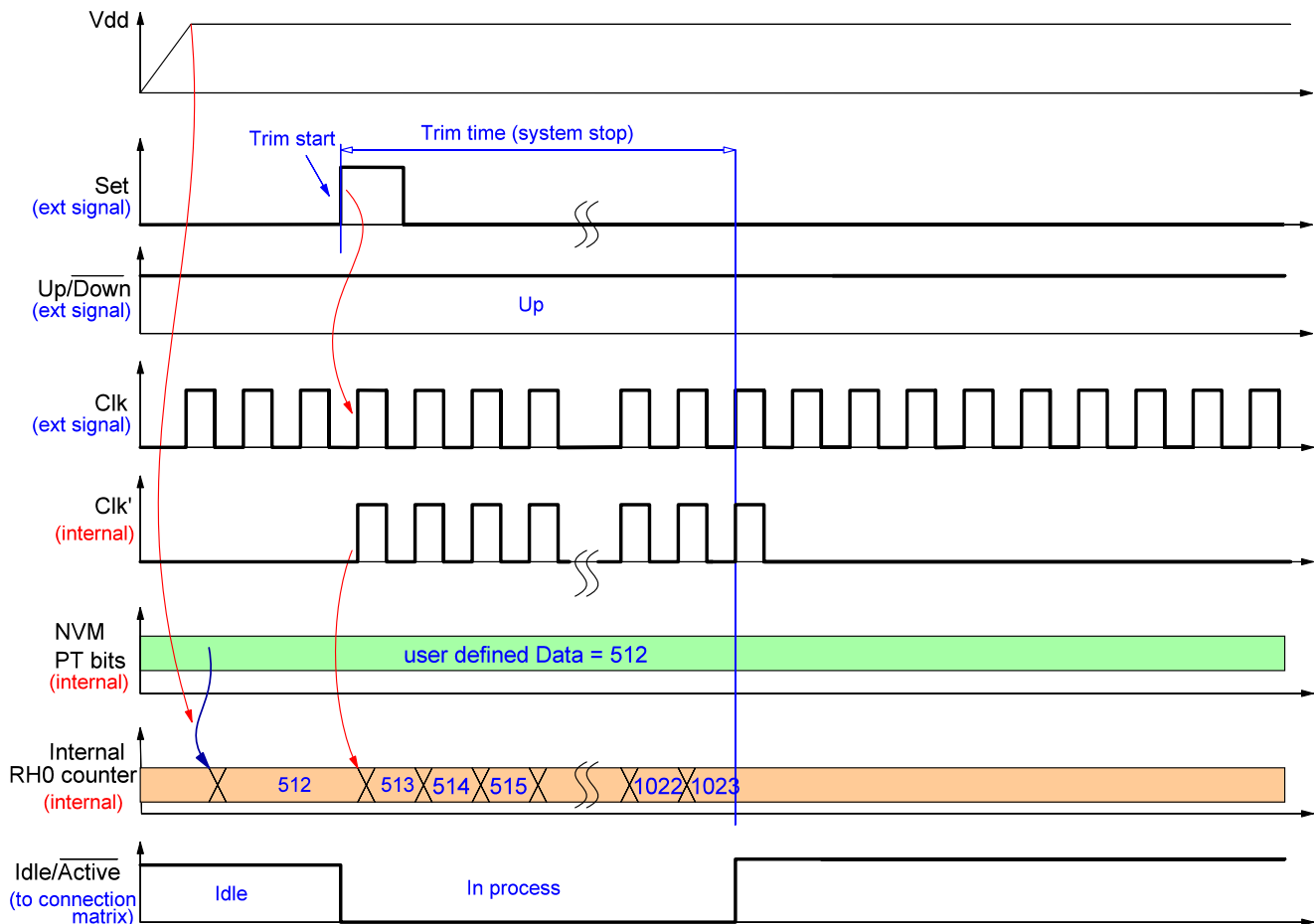

Figure 176: Example of Auto-Trim Process with External Clock Signal

SLG47004

GreenPAK Programmable Mixed-Signal Matrix with In-System Programmability and Advanced Analog Features

Figure 177 shows Auto-Trim process flow for two rheostats.

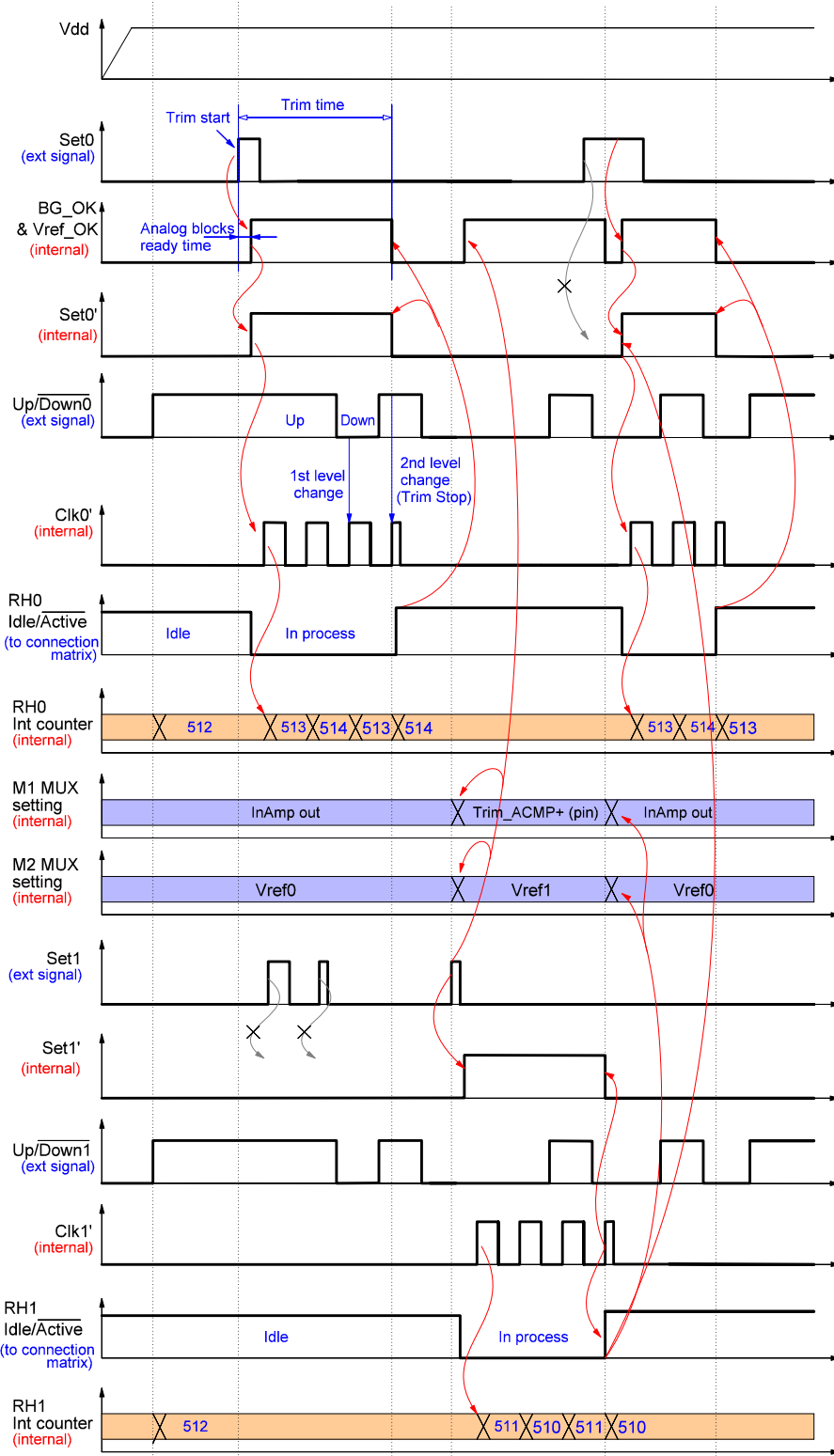

Figure 177: Example of Auto-Trim Process for Two Rheostats

SLG47004

GreenPAK Programmable Mixed-Signal Matrix with In-System Programmability and Advanced Analog Features

12.4.2 I²C Controlled Trimming Process with Auto-Trim Option Enabled

It's possible to start the Auto-Trim process via I²C interface. In this case the user must configure the SLG47004 PT macrocell as described in Section 12.4.1. To start the Auto-Trim process via I²C interface the user can use I²C virtual inputs.

Also, an external I²C master device can force the SLG47004 to reload the rheostat value from NVM ("Reload" command) or to copy rheostat value to NVM ("Program" command) using I²C virtual inputs.

See Figure 178 for an example of the Auto-Trim process under external I²C master control.

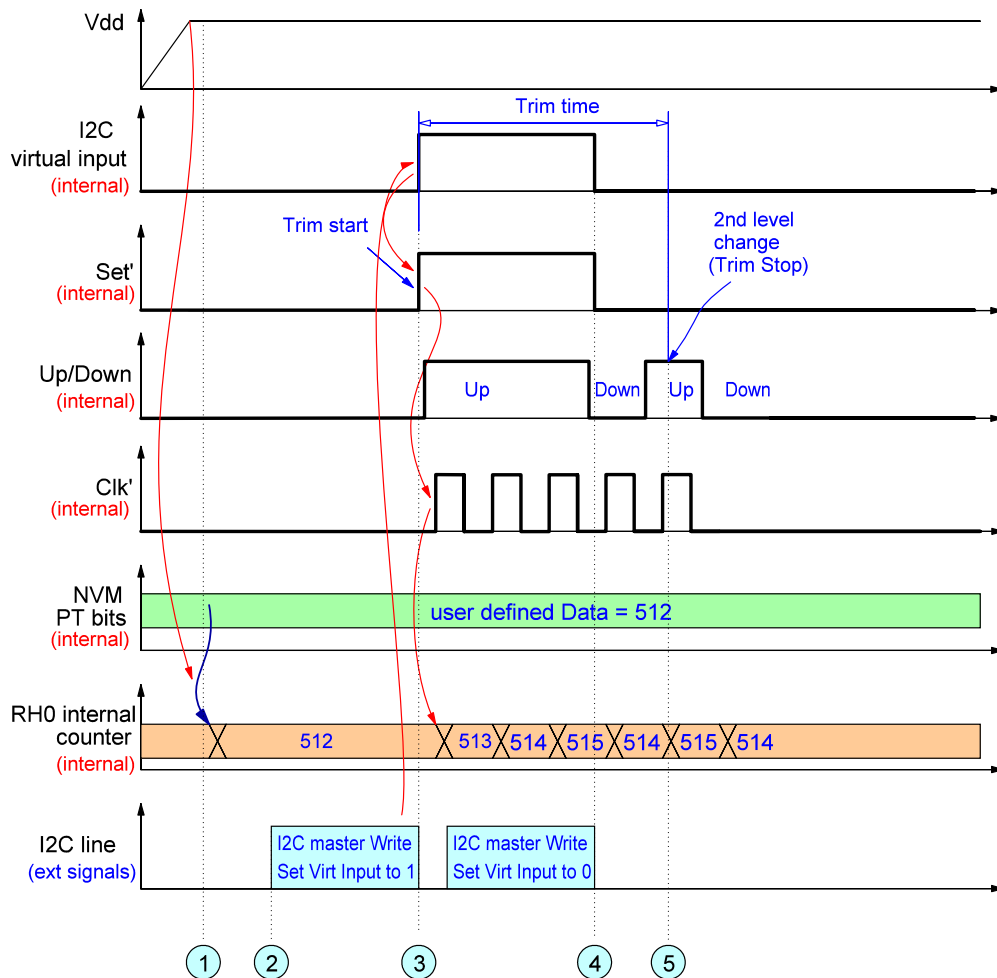

Figure 178: Example of Auto-Trim Process via I²C

The key events of the Auto-Trim process under external I²C master control are as follows:

1. During the startup event the SLG47004 loads the rheostat value from the NVM to the Internal Counter. In the example this value is 512.
2. I²C master sends the message to set High one of the I²C virtual inputs that is connected with Set input of the PT macrocell.
3. After the I²C message is received and processed, the I²C virtual input and the Set input will be at a High logic level. The Auto-Trim process begins.
4. I²C master clears the virtual input and, consequently, the Set input. The Auto-Trim process goes on until a trim stop condition occurs.

SLG47004

GreenPAK Programmable Mixed-Signal Matrix with In-System Programmability and Advanced Analog Features

5. The Auto-Trim process ends. The stop condition in this example is a 2nd change on Up/Down input at the moment of rising edge on the Clock input and Low level at the Set input.

12.4.3 Changing Rheostat Value Directly via I²C

The user can perform their own trim algorithm setting the rheostat value directly via I²C interface. In the example below, a microcontroller uses a user defined trim algorithm to change SLG47004's rheostat via I²C interface (Figure 179). Note that during Auto-Trim process SLG47004 will return nACK, if master tries to get access (both read and write) to rheostats registers via I²C.

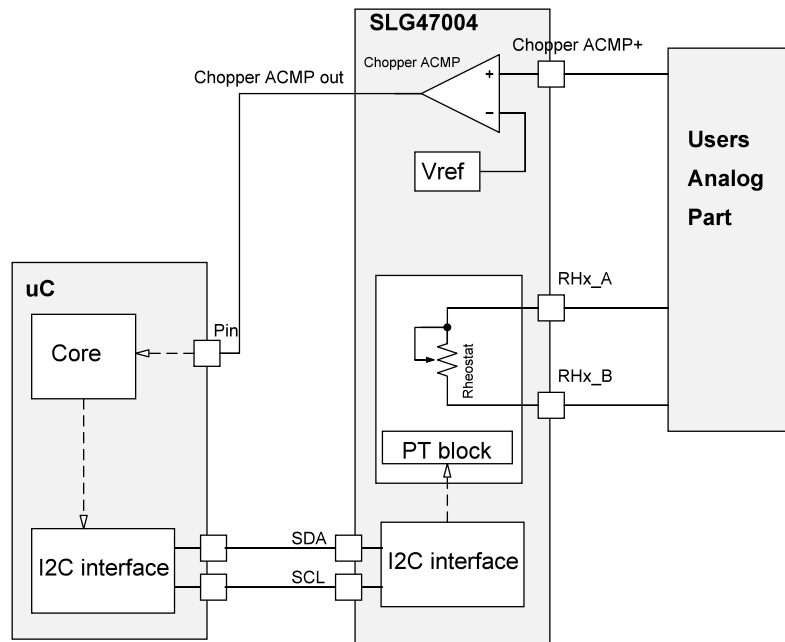

Figure 179: Example of Hardware Configuration

Note that the PT Registers are allowed to read and write via communication interface, if not protected.

The preliminary configuration of system shown in Figure 179 is the following:

- Auto_Cal_Dis_RHx bit is set to 1 (disable Auto-Trim mode);
- M1 MUX (registers [875:872]) is configured to work with user system voltage feedback (pin Chop_ACMP+);
- M2 MUX is configured to work with SLG47004 programmable Vref. Note that M2 MUX is simplified symbol of Chopper ACMP reference selection blocks (see Section 9.2);
- Chopper ACMP is powered up from connection matrix. Chopper ACMP out is connected to output pin;
- No Clock source for PT block.

The example of a system trim via I²C is shown in the figure below. In this example the I²C master uses a simple approximation algorithm for reaching the set point. Every next step the rheostat code is changed by $\pm(\text{Previous rheostat code step value}/2)$. The sign depends on the Chopper ACMP output. The algorithm steps are as follows:

- Set rheostat code to $1024/2 = 512$;
- Wait until the system settles down and check if Chopper ACMP output = 1, then $\text{Next_rheostat_code} = 512 + (512/2)$. If Chopper ACMP output = 0, then $\text{Next_rheostat_code} = 512 - (512/2)$;
- Repeat previous step until $\text{Next_rheostat_code} = \text{Prev_rheostat_code} \pm 1$;

SLG47004

GreenPAK Programmable Mixed-Signal Matrix with In-System Programmability and Advanced Analog Features

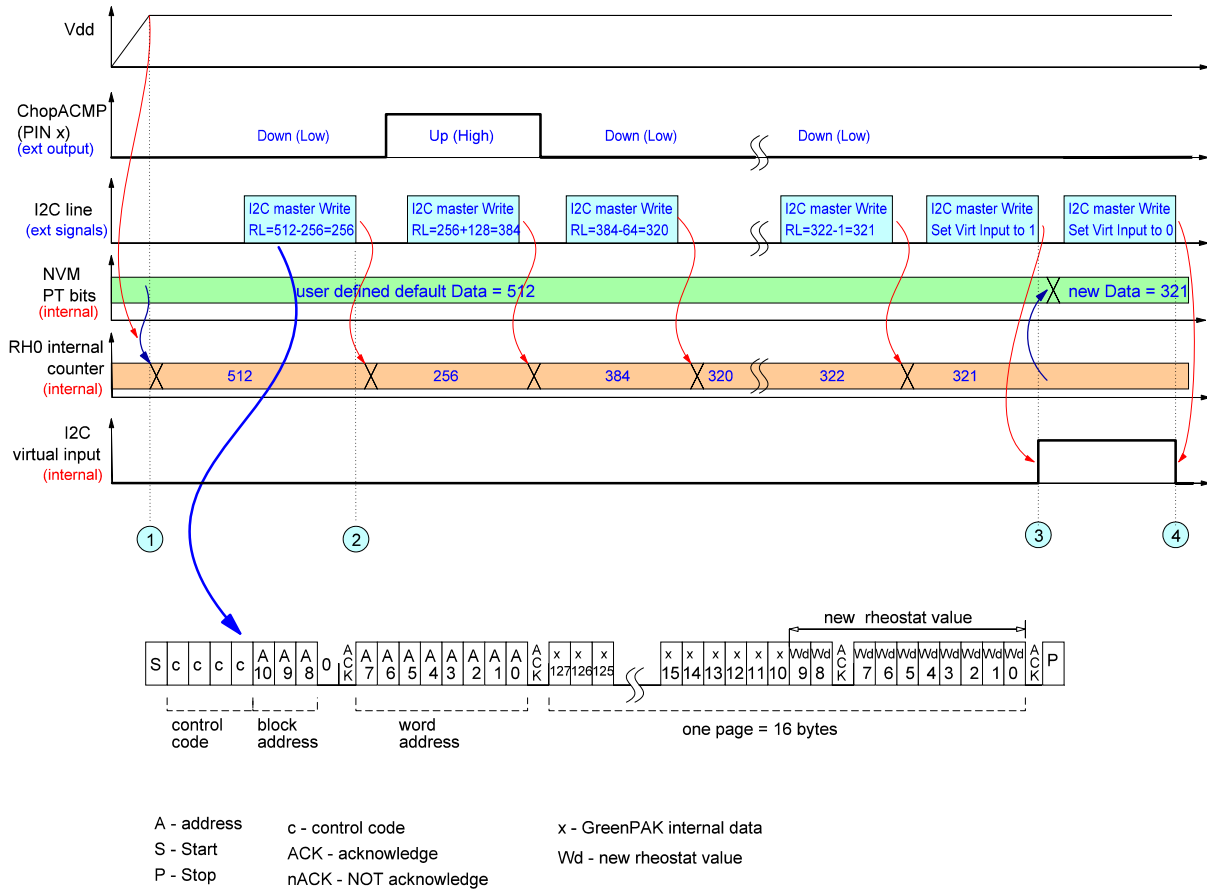

Figure 180: Example of User Specific Trimming Process under I²C Master Control

The key events of a user specific trimming process under I²C master control are as follows:

1. During the startup event the SLG47004 loads the rheostat value from NVM to Internal Counter. In the example this value is 512.
2. I²C master writes a new value to the Rheostat's Internal Counter according to Chopper ACMP output. Note that the minimum time for changing the rheostat code depends on the time response of the user system.
3. After the trim process is completed, the I²C master sets the I²C virtual input to logic "1". This input is connected to the "Program" signal of the PT macrocell. The rising edge on this input starts the NVM self-programming routine.
4. The I²C master clears the I²C virtual input.

Additionally, the I²C Master macrocell can use internal resources such as an ADC to read the system data, find the error, and then adjust the Rheostat value. Also, it is possible to change the Rheostat value for different conditions. For example, the I²C Master macrocell can change the Rheostat value based on the temperature change to reduce the system error.

12.5 USING CHOPPER ACMP

When the Auto-Trim Function is disabled, the Chopper comparator can be used as a standalone analog comparator. Inputs of the Chopper ACMP are selected by the M1 and M2 analog MUXs. Output of the Chopper ACMP can be optionally inverted by register [882]. This comparator output is the input [55] of the connection matrix. In case of a disabled Auto-Trim Function, the power up source for the Chopper ACMP comes from connection matrix. Please refer to Section 9 for more details.

SLG47004

GreenPAK Programmable Mixed-Signal Matrix
with In-System Programmability and Advanced Analog Features

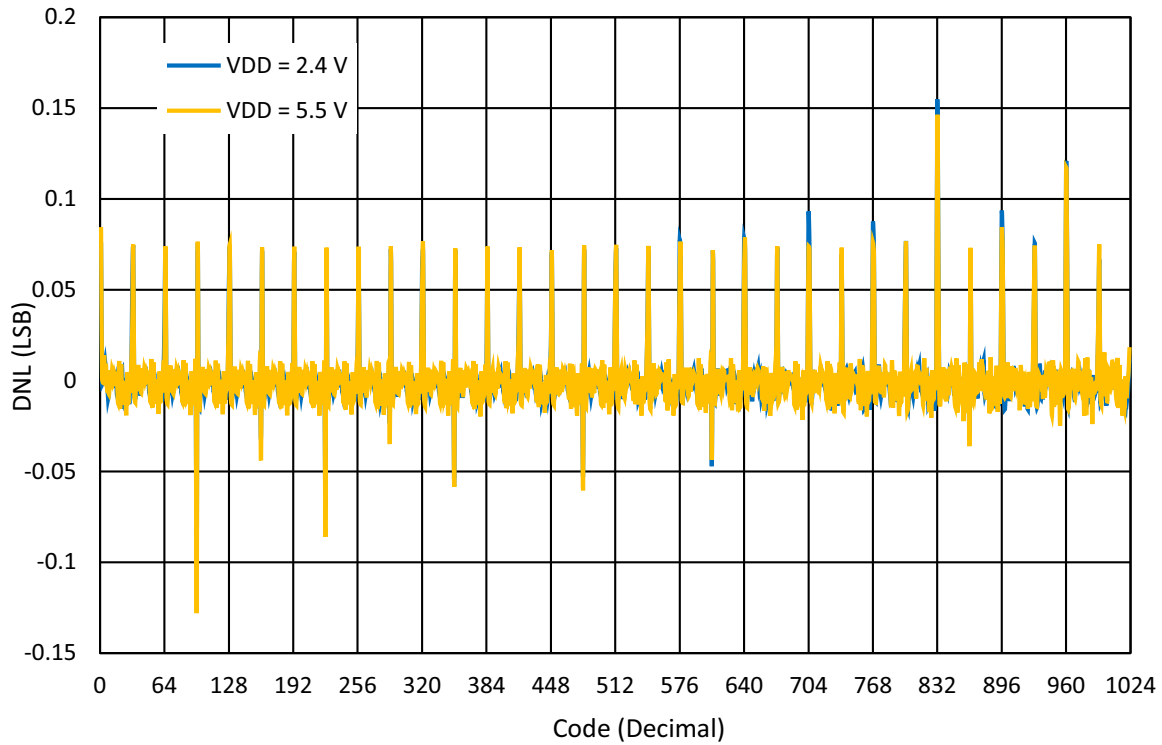

Figure 181: DNL vs. Digital Code, Rheostat Mode ($V_{AB} = 1\text{ V}$) at $T = 25\text{ }^{\circ}\text{C}$

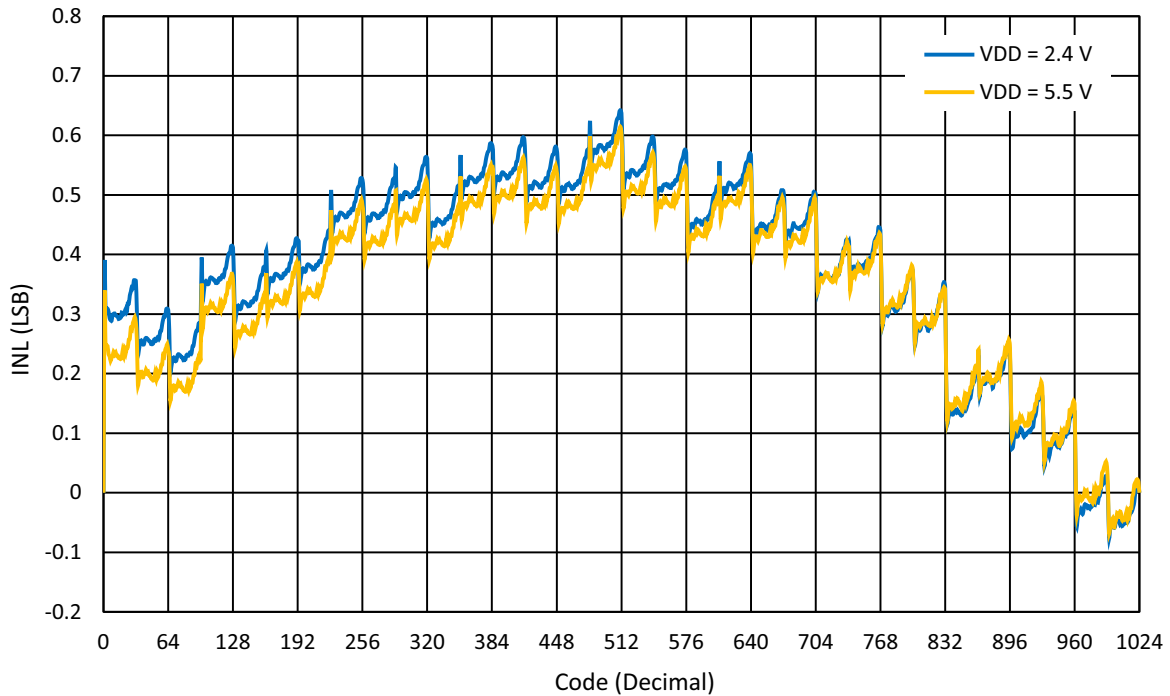

Figure 182: INL vs. Digital Code, Rheostat Mode ($V_{AB} = 1\text{ V}$) at $T = 25\text{ }^{\circ}\text{C}$

SLG47004

GreenPAK Programmable Mixed-Signal Matrix
with In-System Programmability and Advanced Analog Features

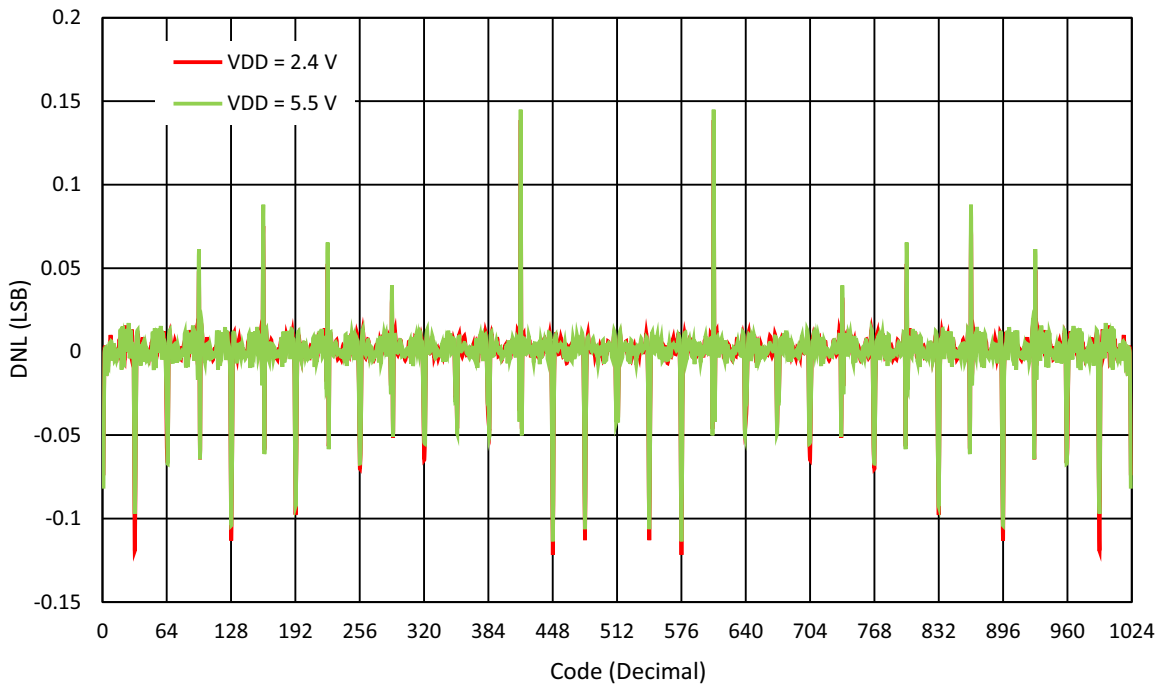

Figure 183: DNL vs. Digital Code, Potentiometer Mode ($V_{AB} = 1\text{ V}$) at $T = 25\text{ °C}$

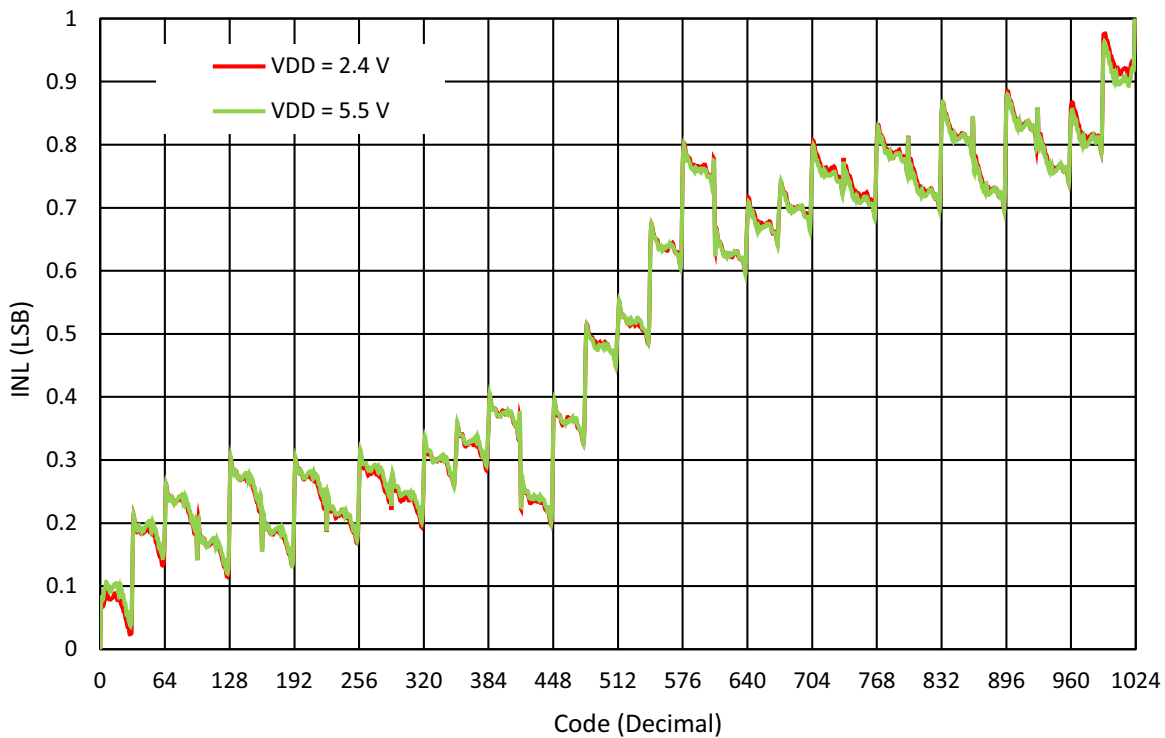

Figure 184: INL vs. Digital Code, Potentiometer Mode ($V_{AB} = 1\text{ V}$) at $T = 25\text{ °C}$

SLG47004

GreenPAK Programmable Mixed-Signal Matrix
with In-System Programmability and Advanced Analog Features

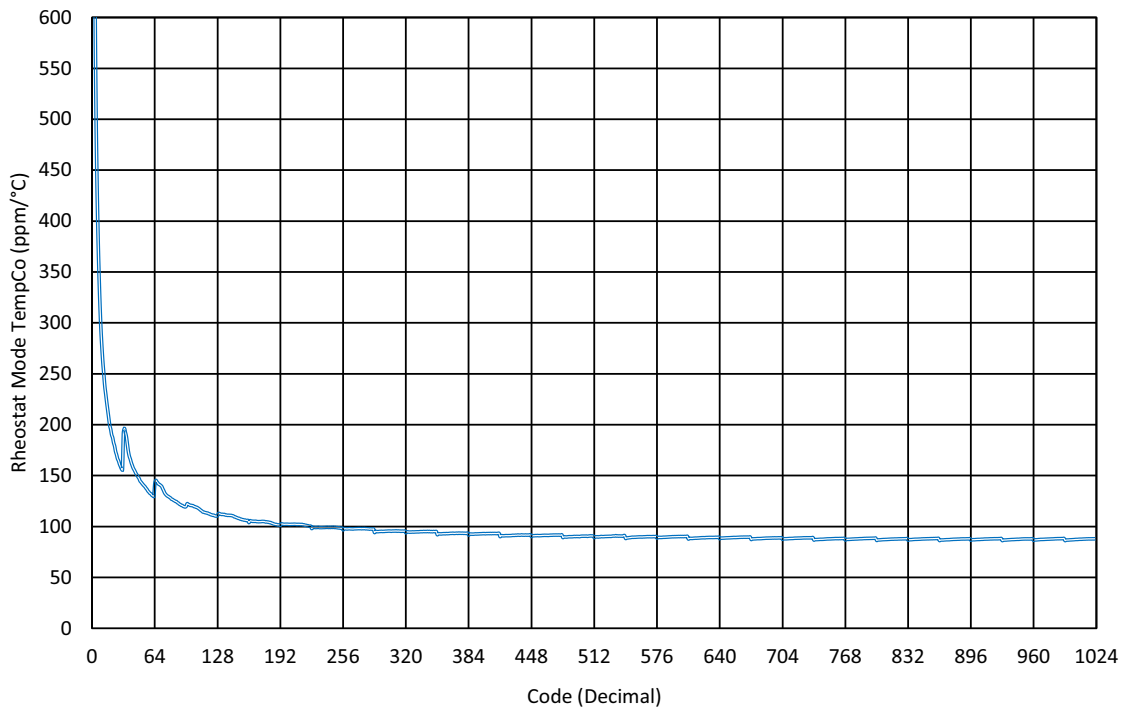

Figure 185: $(\Delta R_{AB}/R_{AB})/\Delta T_A$ Rheostat Mode Tempco

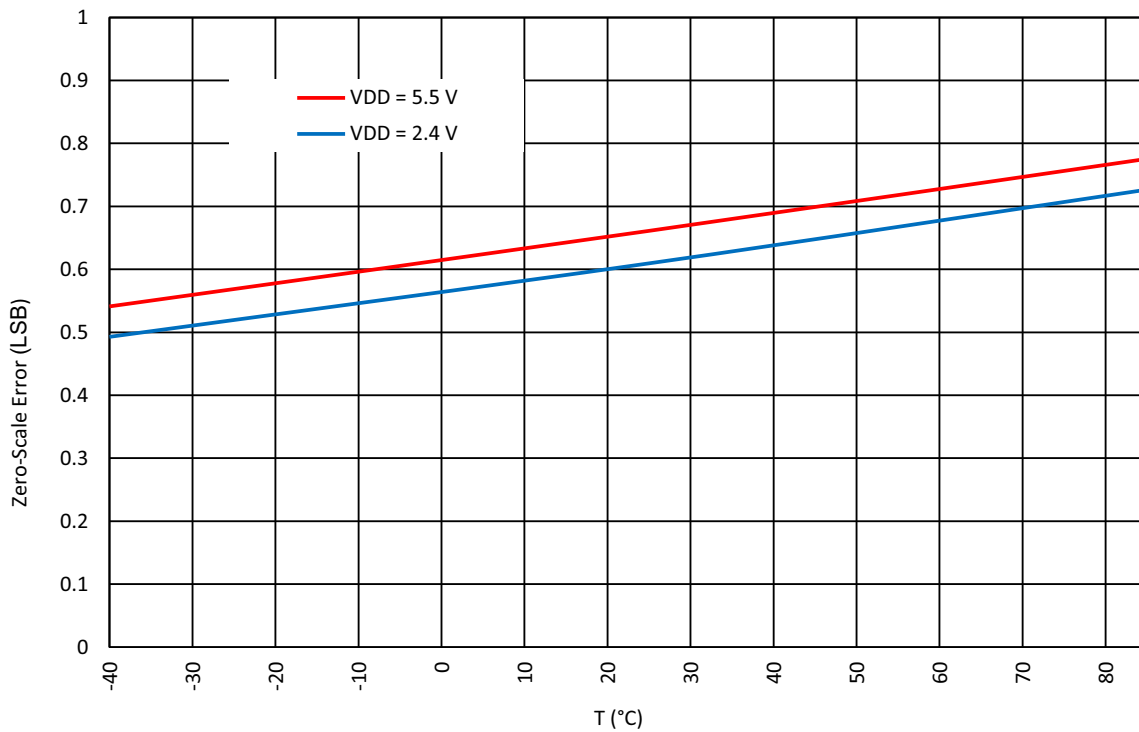

Figure 186: RHx Zero Scale Error vs. Temperature ($V_{IN} = 1\text{ V}$)

SLG47004

GreenPAK Programmable Mixed-Signal Matrix
with In-System Programmability and Advanced Analog Features

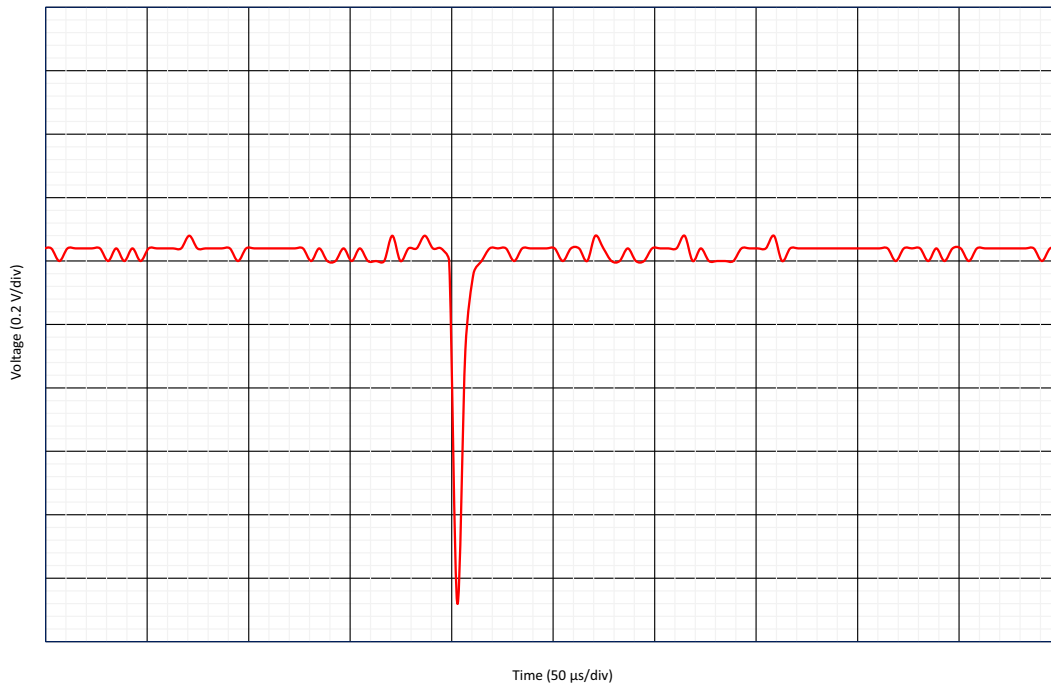

Figure 187: Transition Glitch in Worst Case (Code = 511 to Code = 512)

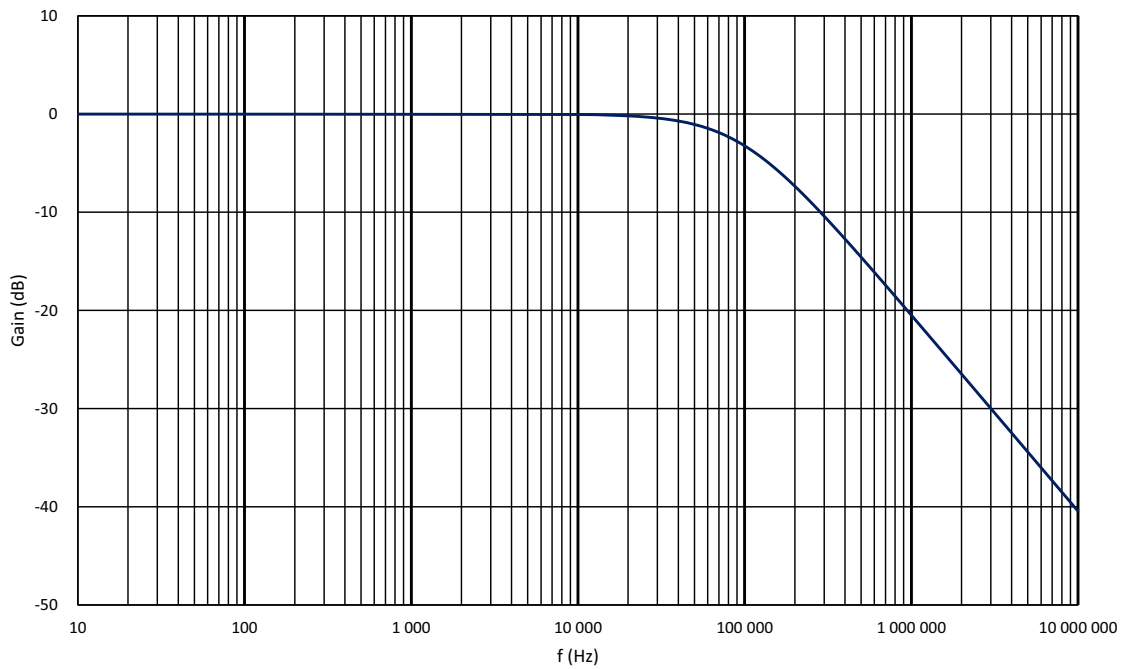

Figure 188: Gain vs. Frequency (Code = 512) at T = 25 °C, V_{DDA} = 5 V

SLG47004

GreenPAK Programmable Mixed-Signal Matrix
with In-System Programmability and Advanced Analog Features

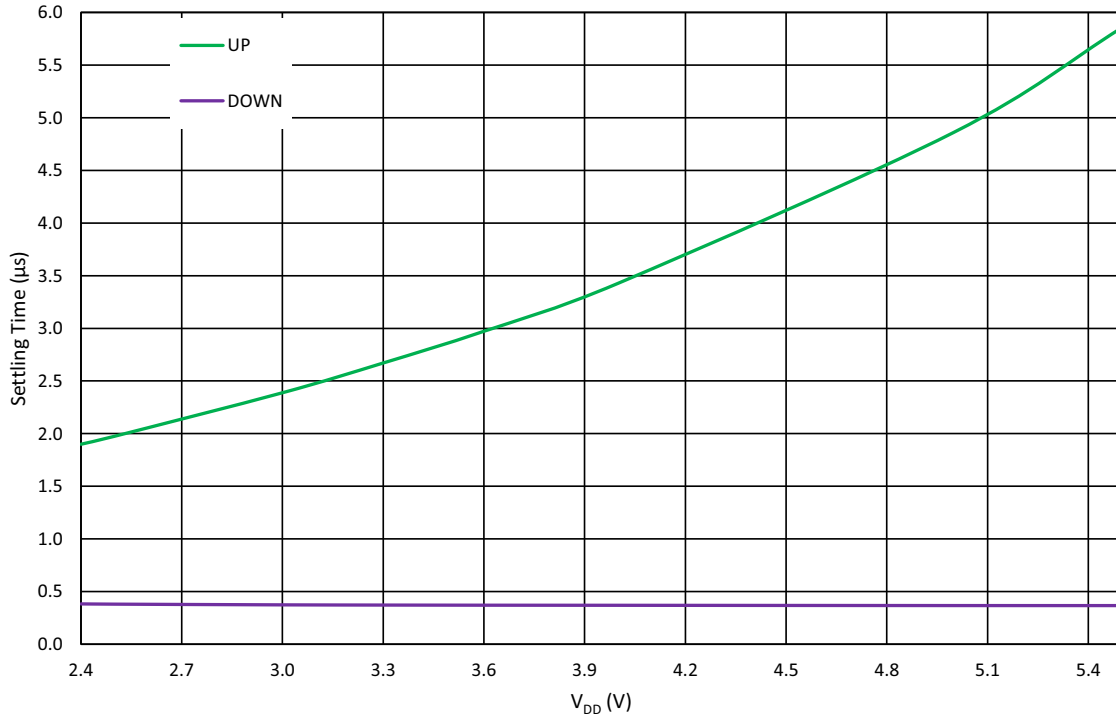

Figure 189: RHx Settling Time vs. V_{DD} at I_{LOAD} = 1 mA, T = 25 °C

SLG47004

GreenPAK Programmable Mixed-Signal Matrix with In-System Programmability and Advanced Analog Features

13 Programmable Delay/Edge Detector

The SLG47004 has a programmable time delay logic cell available, that can generate a delay that is selectable from one of four timings (time 2) configured in the GreenPAK Designer. The programmable time delay cell can generate one of four different delay patterns, rising edge detection, falling edge detection, both edge detection, and both edge delay. These four patterns can be further modified with the addition of delayed edge detection, which adds an extra unit of delay, as well as glitch rejection during the delay period. See Figure 191 for further information.

Note: The input signal must be longer than the delay, otherwise it will be filtered out.

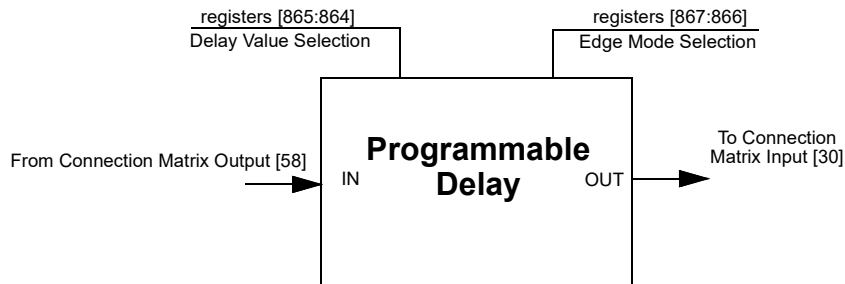

Figure 190: Programmable Delay

13.1 PROGRAMMABLE DELAY TIMING DIAGRAM - EDGE DETECTOR OUTPUT

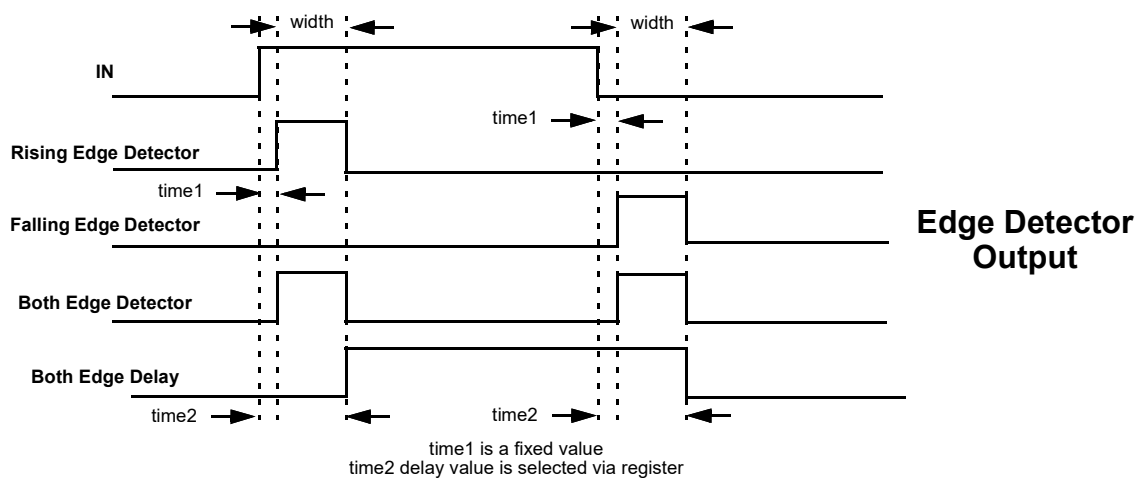

Figure 191: Edge Detector Output

Please refer to Table 12.

SLG47004

GreenPAK Programmable Mixed-Signal Matrix with In-System Programmability and Advanced Analog Features

14 Additional Logic Function. Deglitch Filter

The SLG47004 has one Deglitch Filter macrocell with inverter function that is connected directly to the Connection Matrix inputs and outputs. In addition, this macrocell can be configured as an Edge Detector, with the following settings:

- Rising Edge Detector
- Falling Edge Detector
- Both Edge Detector
- Both Edge Delay

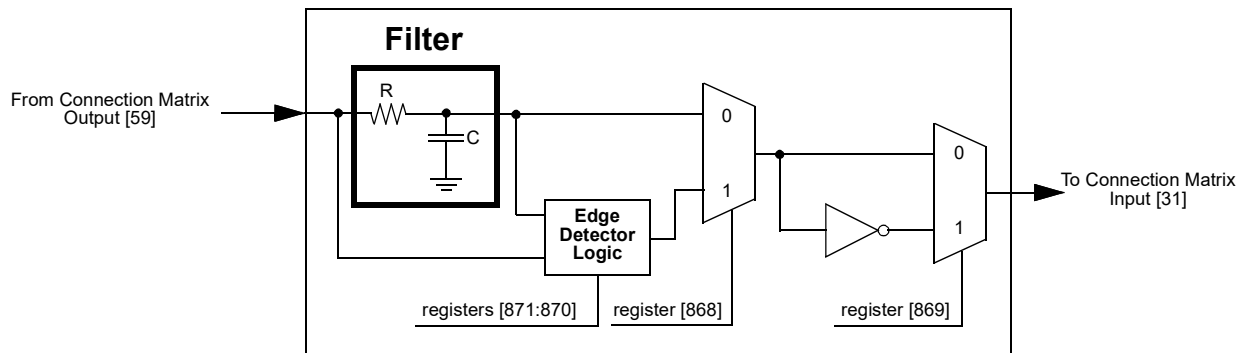

Figure 192: Deglitch Filter or Edge Detector

SLG47004

GreenPAK Programmable Mixed-Signal Matrix with In-System Programmability and Advanced Analog Features

15 Voltage Reference

15.1 VOLTAGE REFERENCE OVERVIEW

The SLG47004 has a Voltage Reference (Vref) Macrocell to provide reference to analog comparators and operational amplifiers. The macrocell also has the option to output reference voltages on external pins (see Table 1). Vref0 and Vref1 share output buffers with Temperature sensor. Note that user can use any of output buffers, but Temperature sensor is calibrated for Vref1 output buffer. See Table 58 for the available selections for each analog comparator. Also, see Figure 193, Figure 194, and Figure 195, which show the reference output structure.

Also there is a high drive voltage reference macrocell called HD Buffer. The purpose of this macrocell is to provide stable voltage to the relatively high-power load (Please refer to the Table 19). HD Buffer has shared voltage reference source with the Op Amp0 Vref. User can select output voltage in the range from $V_{DD}/64$ to V_{DD} with a step $V_{DD}/64$, or output voltage in a range from 32 mV to 2.048 V with a step 32 mV (see Figure 195).

Note that Chopper ACMP will automatically enable HD Buffer if HD Buffer is selected as a source for Chopper ACMP In-signal (register 946 = 0) and Chopper ACMP is powered up.

15.2 VREF SELECTION TABLE

Table 58: Vref Selection Table

SEL[5:0]	Vref	SEL[5:0]	Vref
0	0.032	33	1.088
1	0.064	34	1.12
2	0.096	35	1.152
3	0.128	36	1.184
4	0.16	37	1.216
5	0.192	38	1.248
6	0.224	39	1.28
7	0.256	40	1.312
8	0.288	41	1.344
9	0.32	42	1.376
10	0.352	43	1.408
11	0.384	44	1.44
12	0.416	45	1.472
13	0.448	46	1.504
14	0.48	47	1.536
15	0.512	48	1.568
16	0.544	49	1.6
17	0.576	50	1.632
18	0.608	51	1.664
19	0.64	52	1.696
20	0.672	53	1.728
21	0.704	54	1.76
22	0.736	55	1.792
23	0.768	56	1.824
24	0.8	57	1.856
25	0.832	58	1.888
26	0.864	59	1.92
27	0.896	60	1.952

SLG47004

GreenPAK Programmable Mixed-Signal Matrix with In-System Programmability and Advanced Analog Features

Table 58: Vref Selection Table(Continued)

SEL[5:0]	Vref	SEL[5:0]	Vref
28	0.928	61	1.984
29	0.96	62	2.016
30	0.992	63	2.048
31	1.024	64	External
32	1.056		

SLG47004

GreenPAK Programmable Mixed-Signal Matrix with In-System Programmability and Advanced Analog Features

15.3 VREF BLOCK DIAGRAM

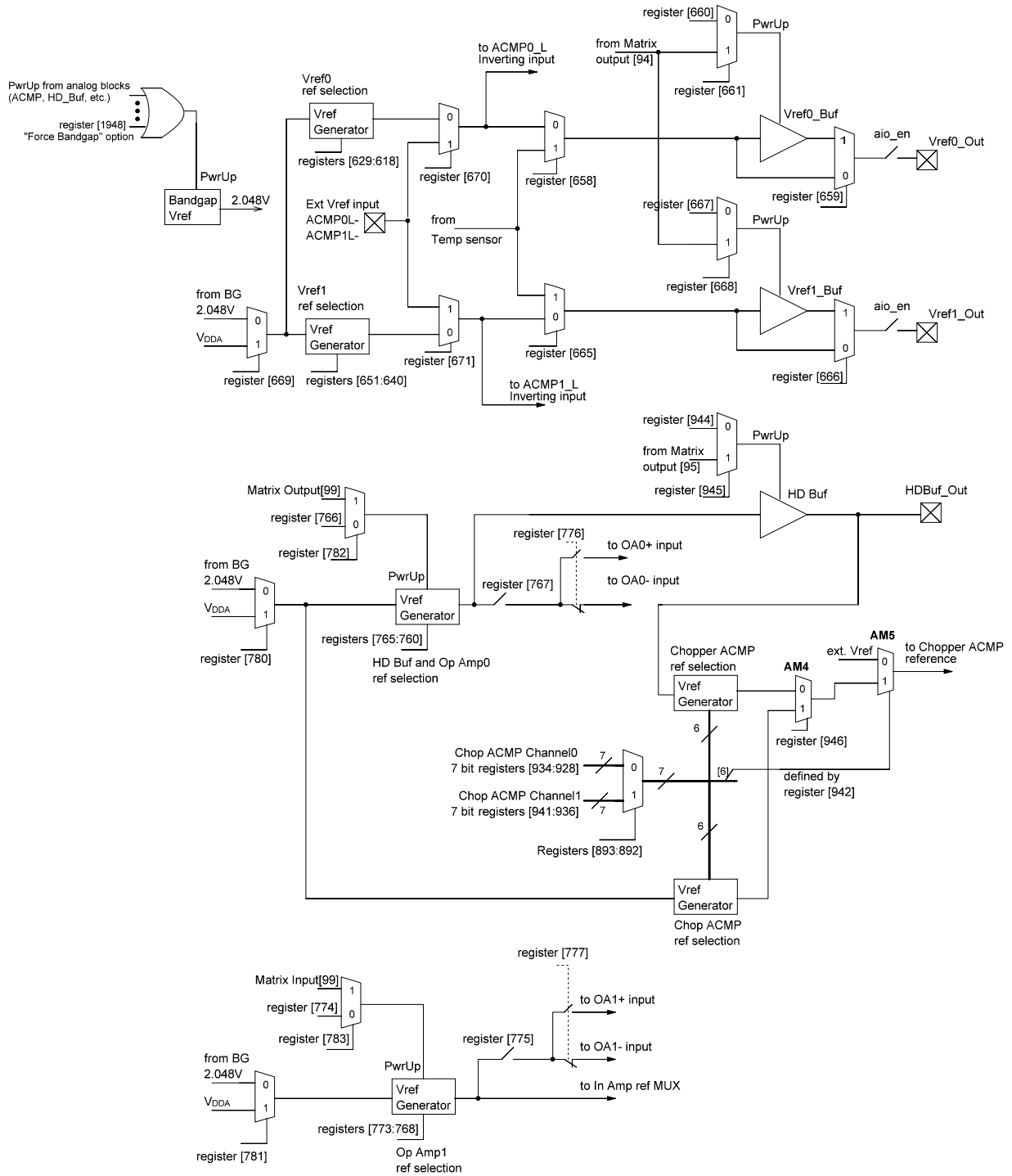

SLG47004

GreenPAK Programmable Mixed-Signal Matrix
with In-System Programmability and Advanced Analog Features

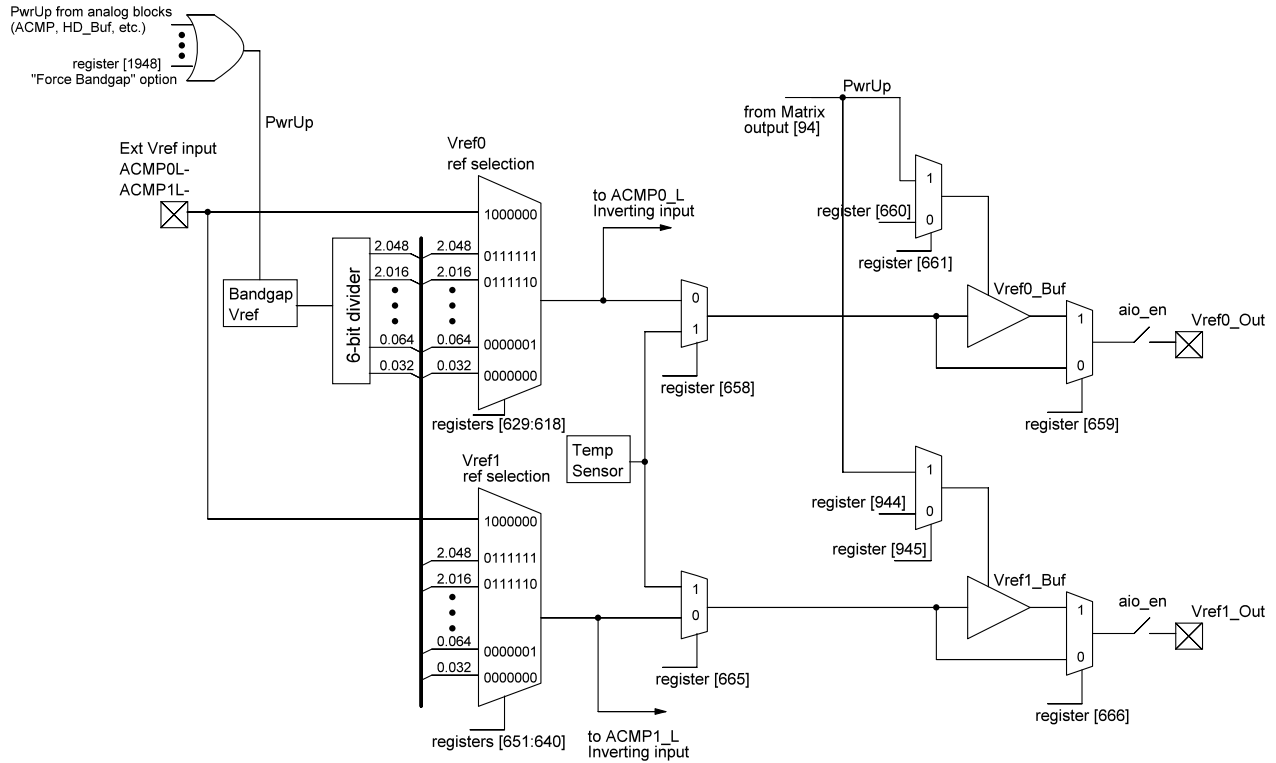

Figure 194: ACMP0L, ACMP1L Voltage Reference Block Diagram

SLG47004

GreenPAK Programmable Mixed-Signal Matrix
with In-System Programmability and Advanced Analog Features

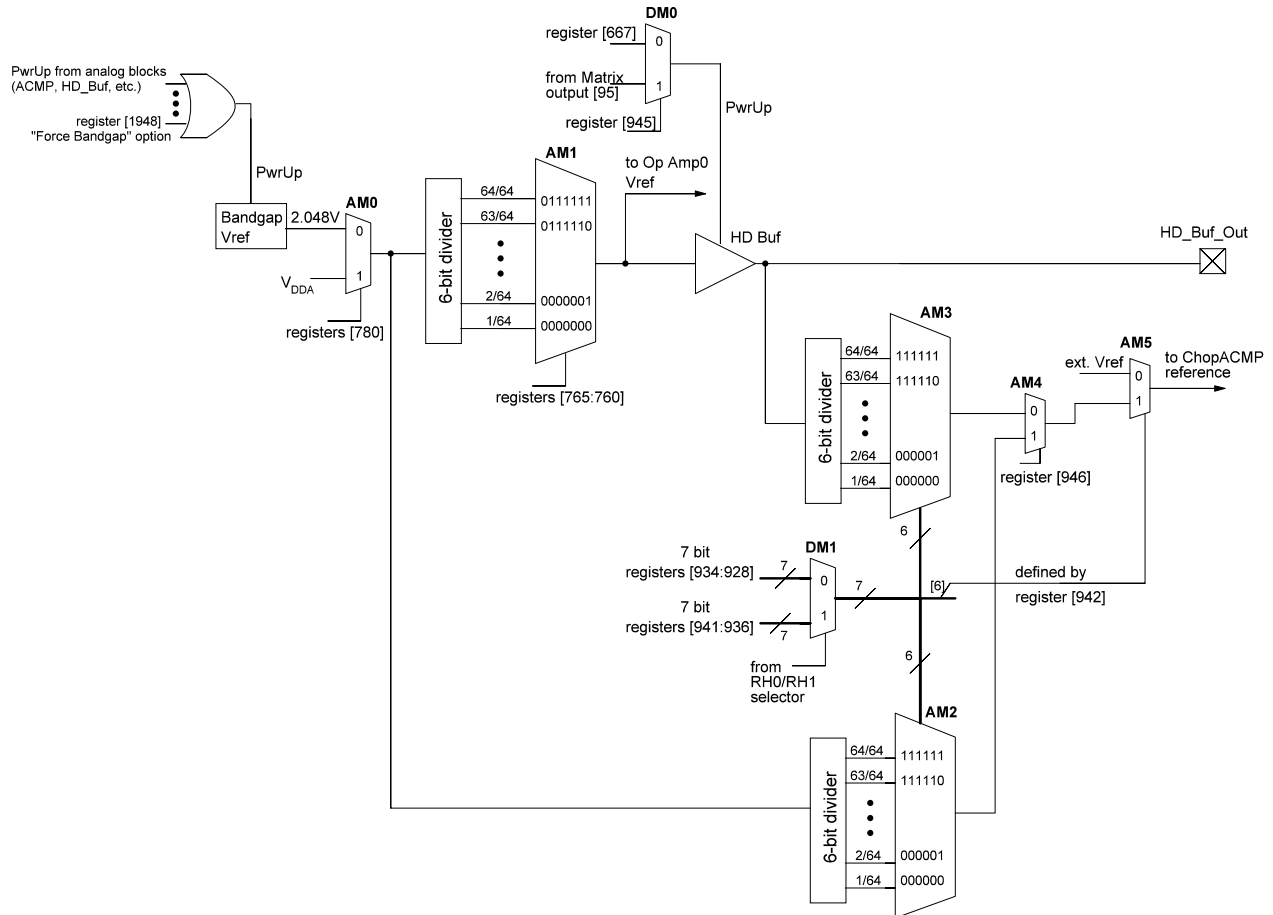

Figure 195: HD Buffer and Chopper ACMP Reference Block Diagram

SLG47004

GreenPAK Programmable Mixed-Signal Matrix with In-System Programmability and Advanced Analog Features

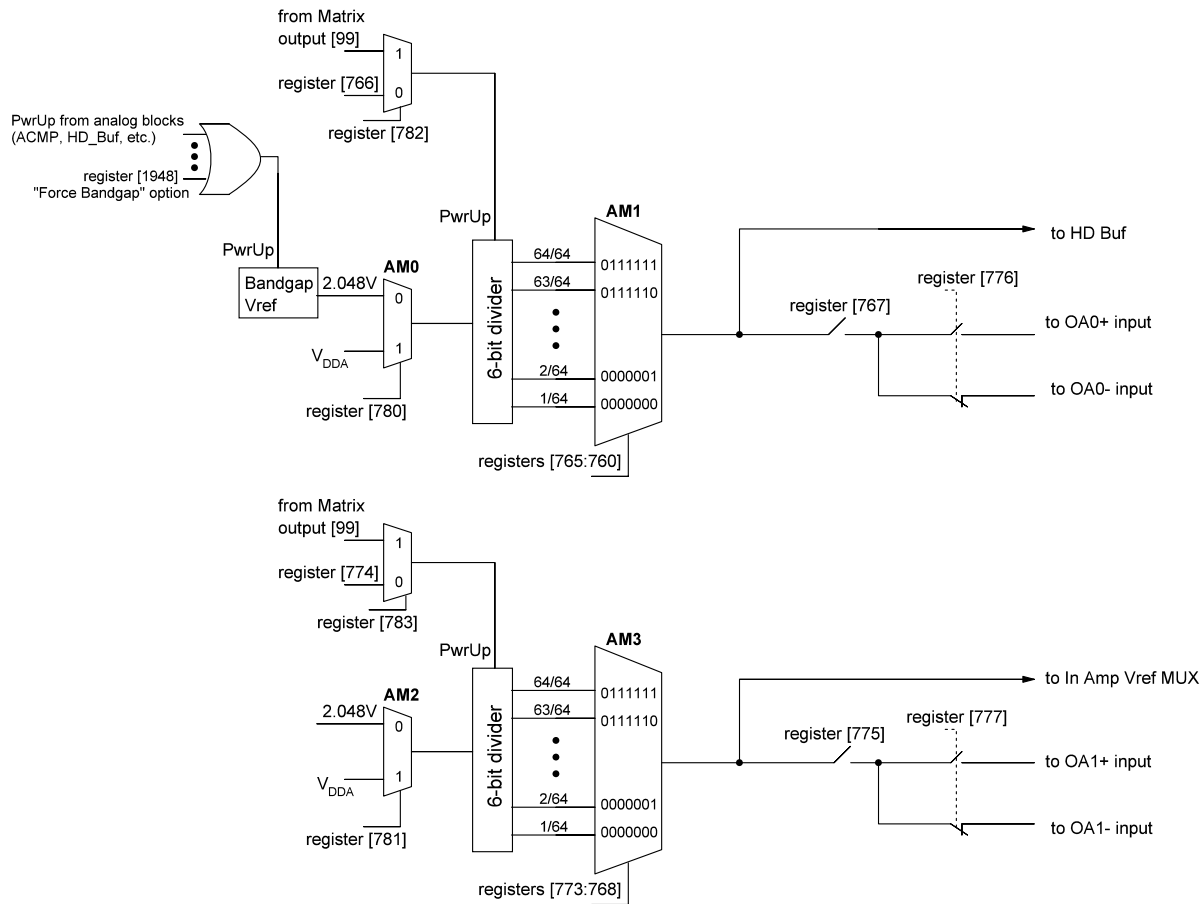

Figure 196: Operational Amplifiers Voltage Reference Block Diagram

SLG47004

GreenPAK Programmable Mixed-Signal Matrix with In-System Programmability and Advanced Analog Features

15.4 VOLTAGE REFERENCE TYPICAL PERFORMANCE

Note 1 It is not recommended to use Vref connected to external pin without buffer.

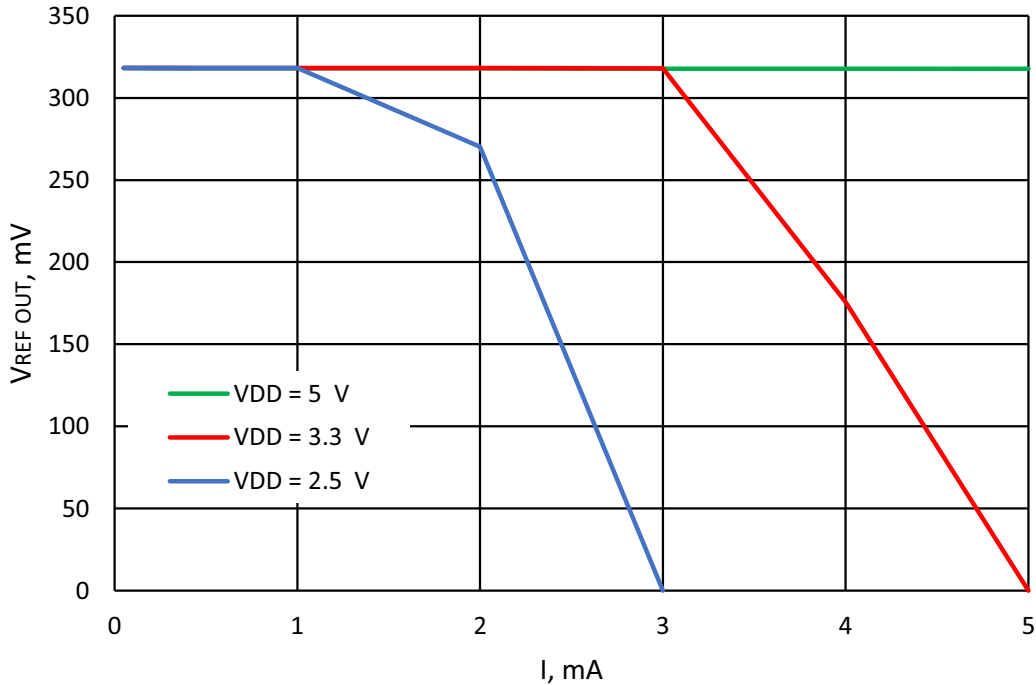

Figure 197: Typical Load Regulation, Vref = 320 mV, T = -40 °C to +85 °C, Buffer - Enable

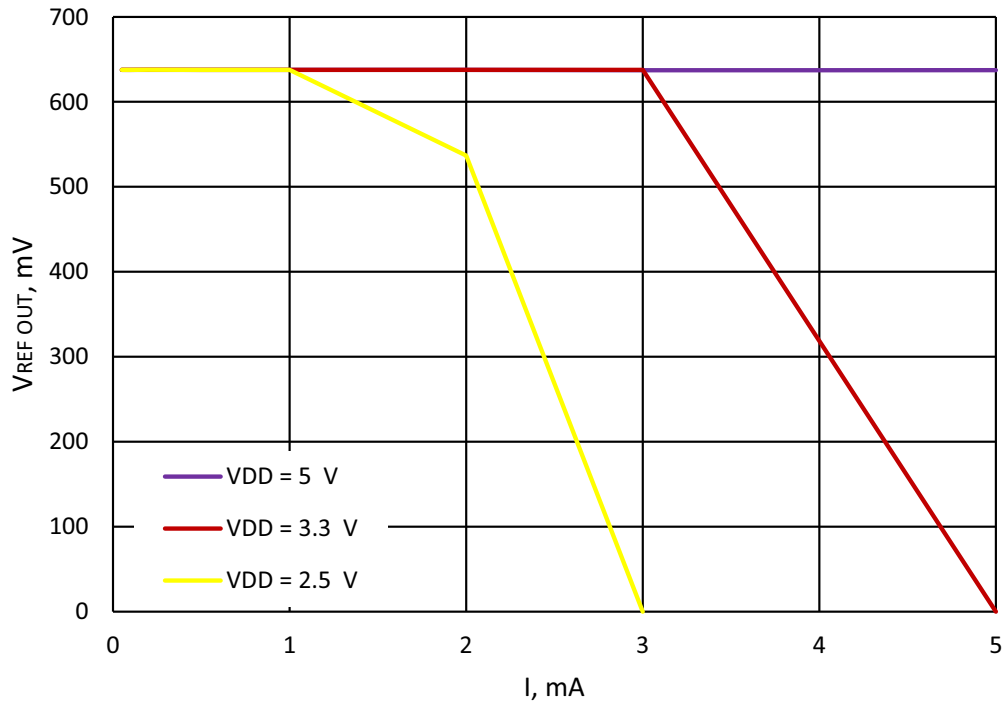

Figure 198: Typical Load Regulation, Vref = 640 mV, T = -40 °C to +85 °C, Buffer - Enable

SLG47004

GreenPAK Programmable Mixed-Signal Matrix
with In-System Programmability and Advanced Analog Features

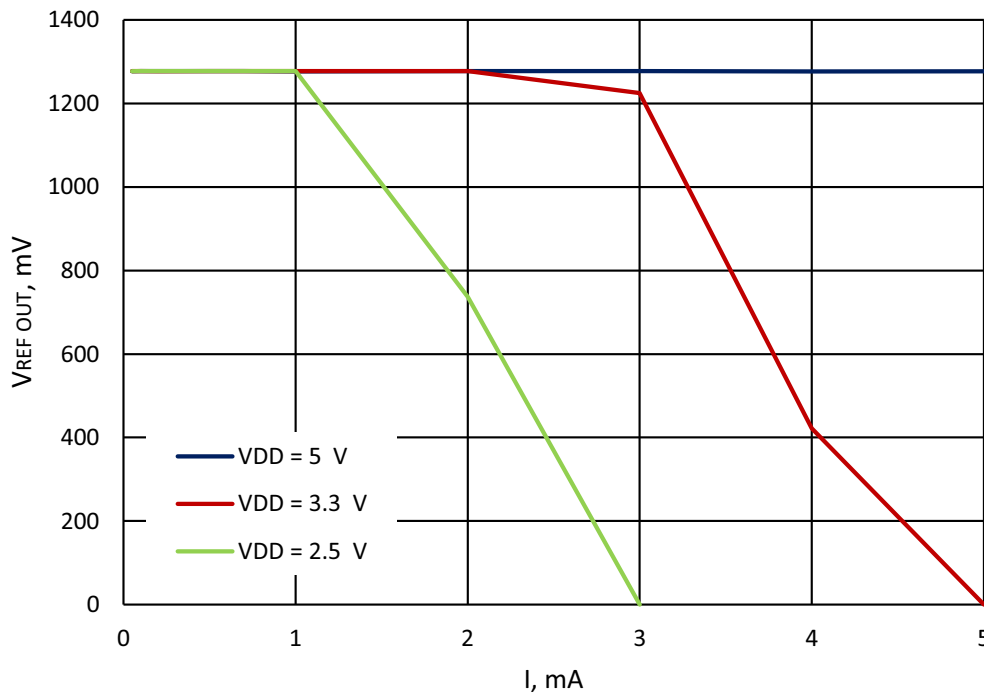

Figure 199: Typical Load Regulation, Vref = 1280 mV, T = -40 °C to +85 °C, Buffer - Enable

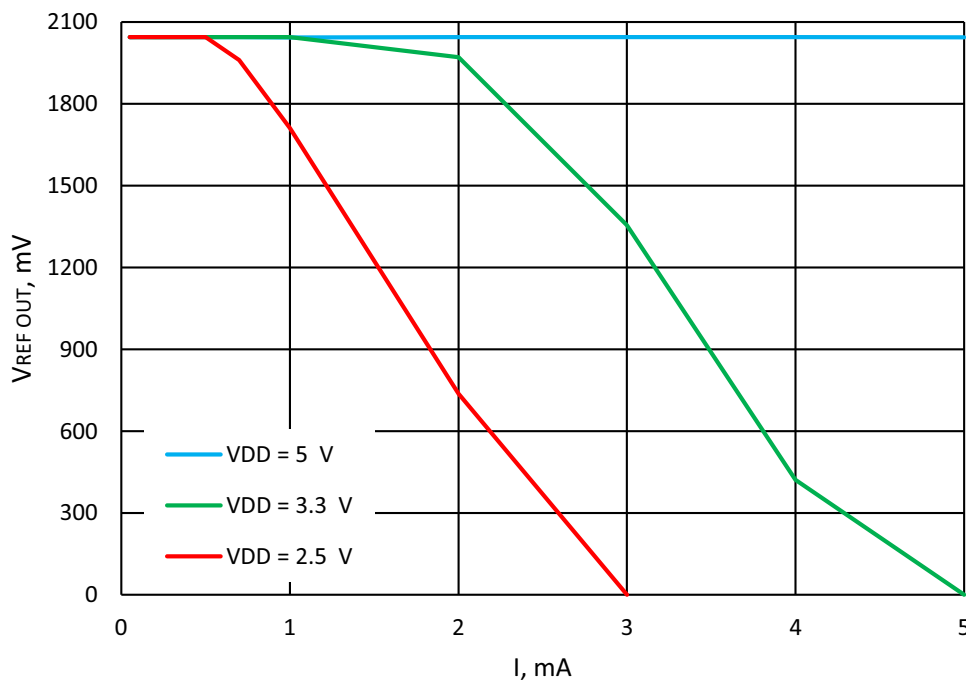

Figure 200: Typical Load Regulation, Vref = 2048 mV, T = -40 °C to +85 °C, Buffer - Enable

SLG47004

GreenPAK Programmable Mixed-Signal Matrix with In-System Programmability and Advanced Analog Features

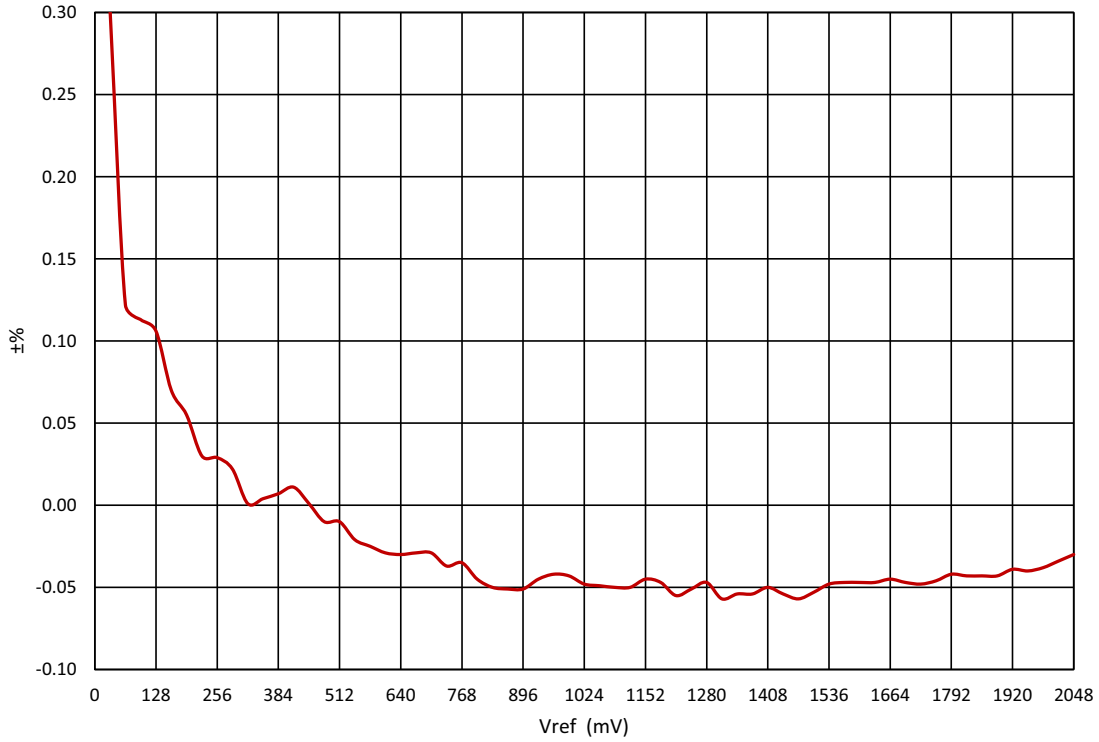

Figure 201: Typical Input Offset Voltage vs. Vref at $V_{DD} = 2.4\text{ V to }5.5\text{ V}$, $T = 25\text{ }^{\circ}\text{C}$, Buffer Disabled

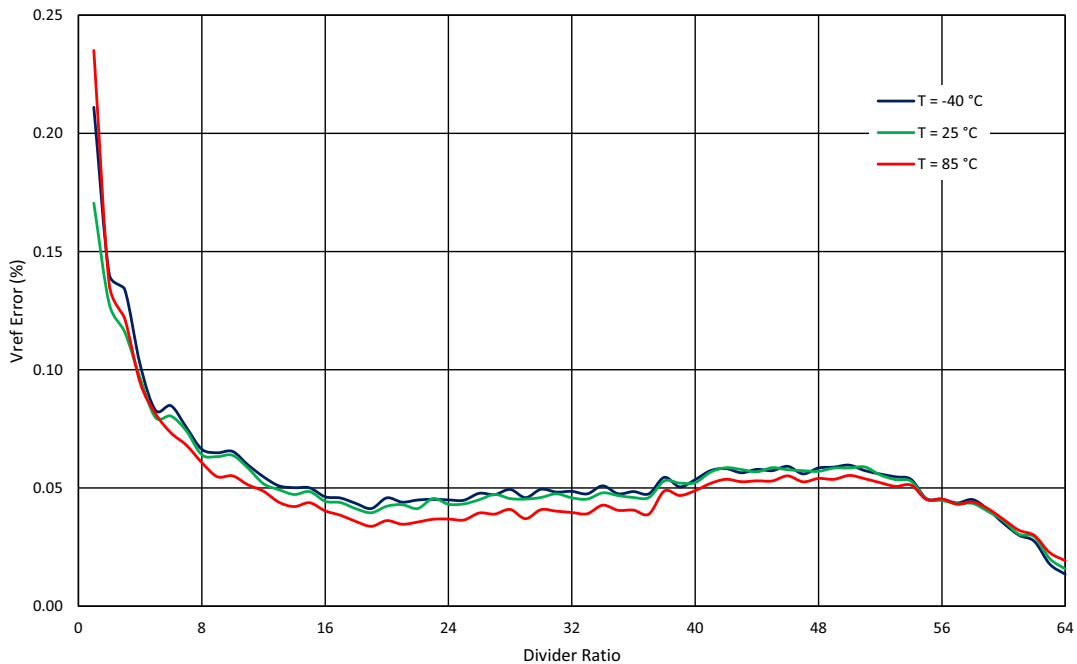

Figure 202: Op Ampx Vref Divider Accuracy at $V_{DD} = 3.3\text{ V}$

SLG47004

GreenPAK Programmable Mixed-Signal Matrix with In-System Programmability and Advanced Analog Features

15.5 HD BUFFER TYPICAL PERFORMANCE

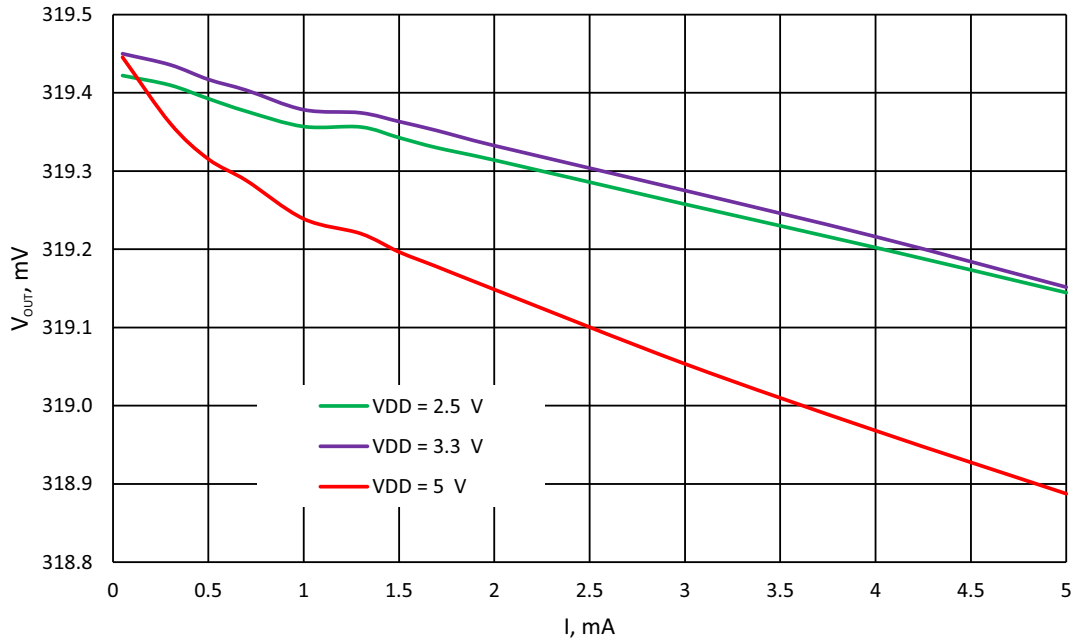

Figure 203: HD Buffer Typical Load Regulation, Vref = 320 mV, T = -40 °C to +85 °C

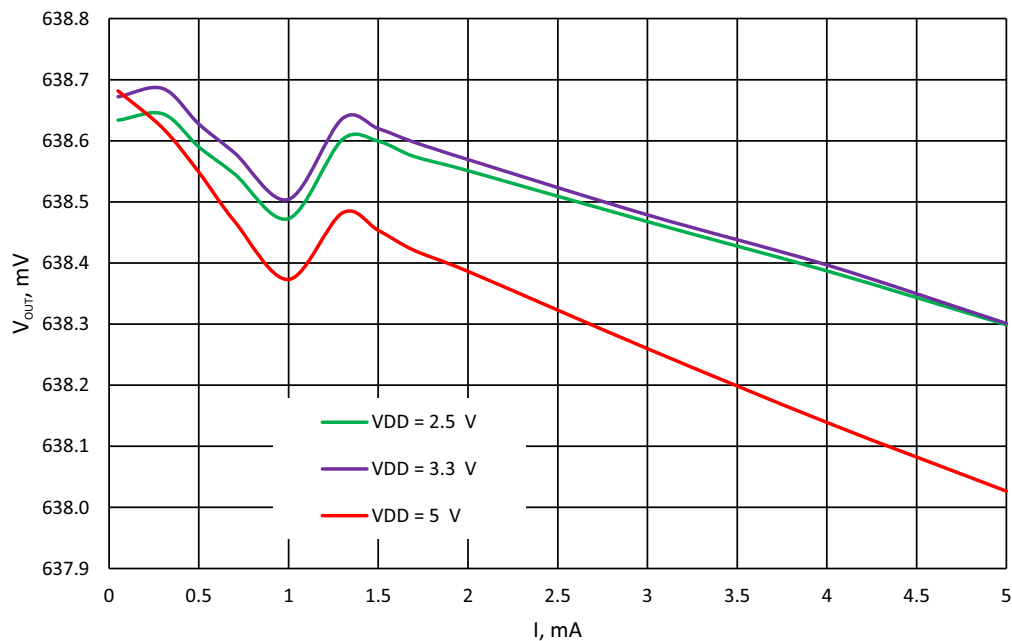

Figure 204: HD Buffer Typical Load Regulation, Vref = 640 mV, T = -40 °C to +85 °C

SLG47004

GreenPAK Programmable Mixed-Signal Matrix
with In-System Programmability and Advanced Analog Features

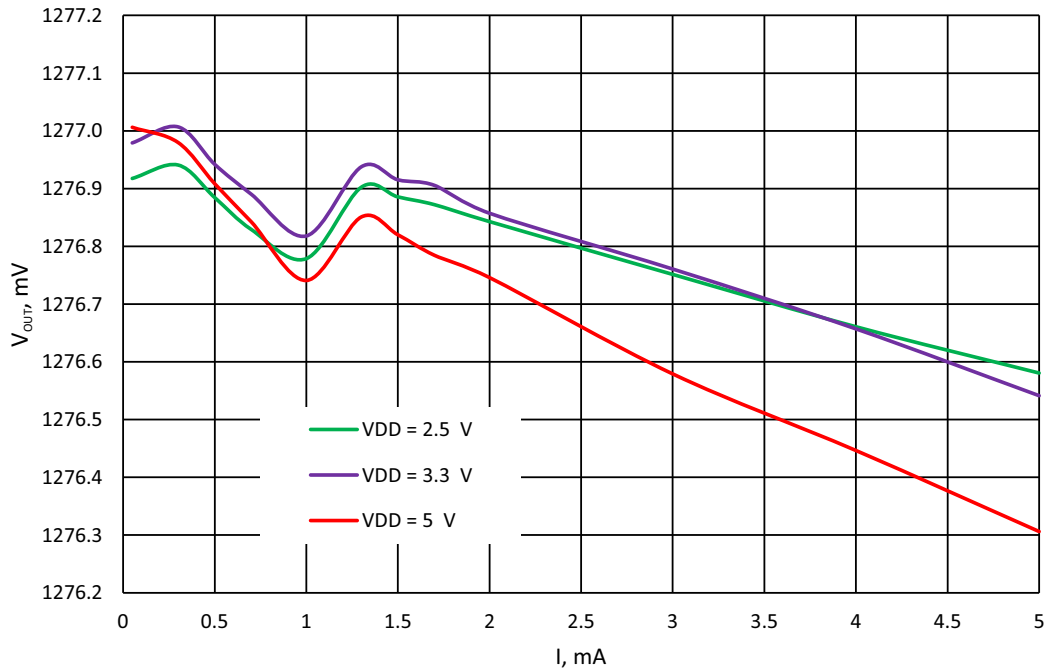

Figure 205: HD Buffer Typical Load Regulation, $V_{ref} = 1280 \text{ mV}$, $T = -40^\circ\text{C}$ to $+85^\circ\text{C}$

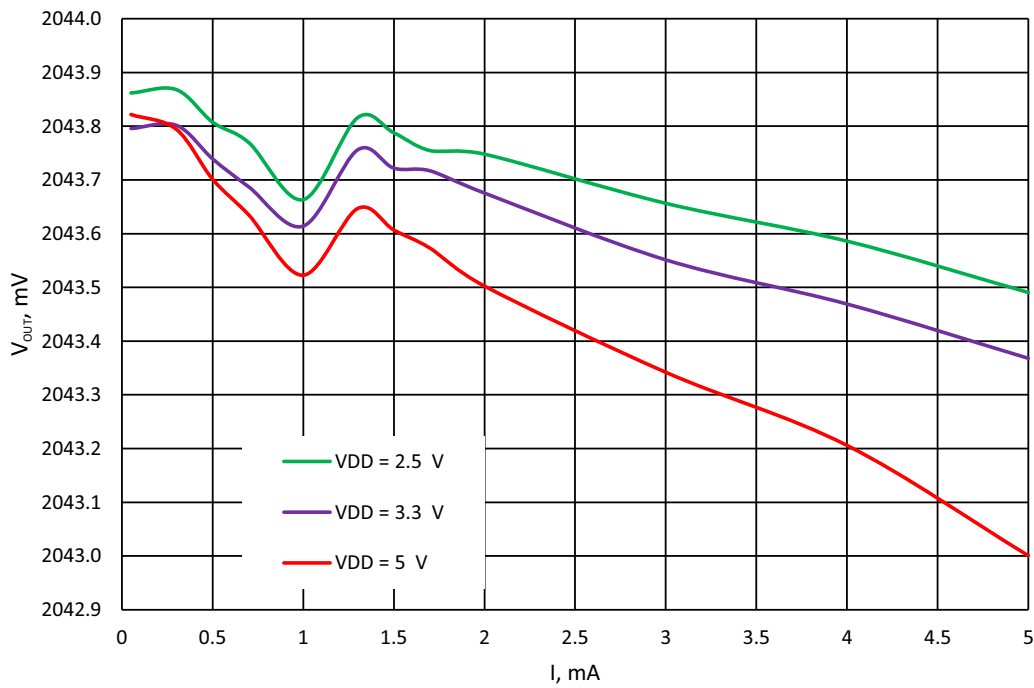

Figure 206: HD Buffer Typical Load Regulation, $V_{ref} = 2048 \text{ mV}$, $T = -40^\circ\text{C}$ to $+85^\circ\text{C}$

SLG47004

GreenPAK Programmable Mixed-Signal Matrix
with In-System Programmability and Advanced Analog Features

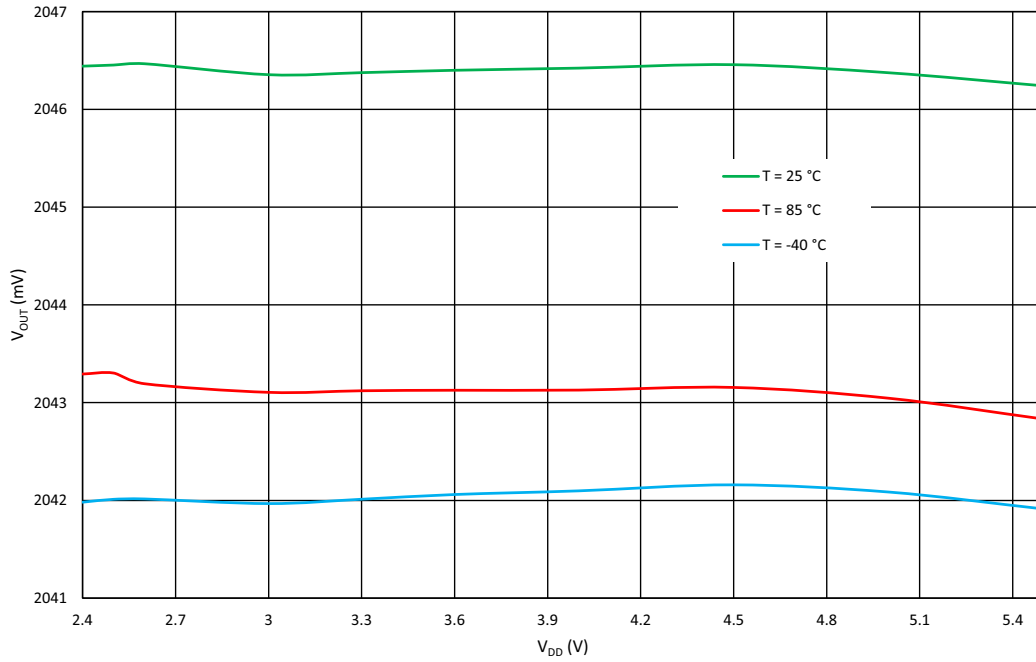

Figure 207: HD Buffer Typical Line Regulation, $I_{LOAD} = 5$ mA

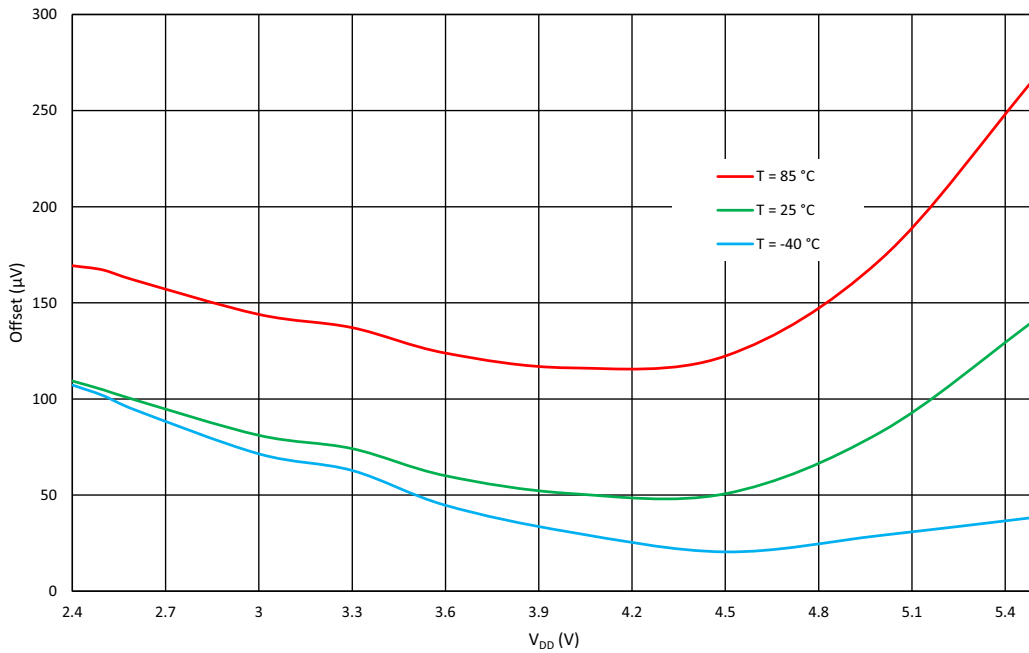

Figure 208: HD Buffer Offset vs. V_{DD}

SLG47004

GreenPAK Programmable Mixed-Signal Matrix
with In-System Programmability and Advanced Analog Features

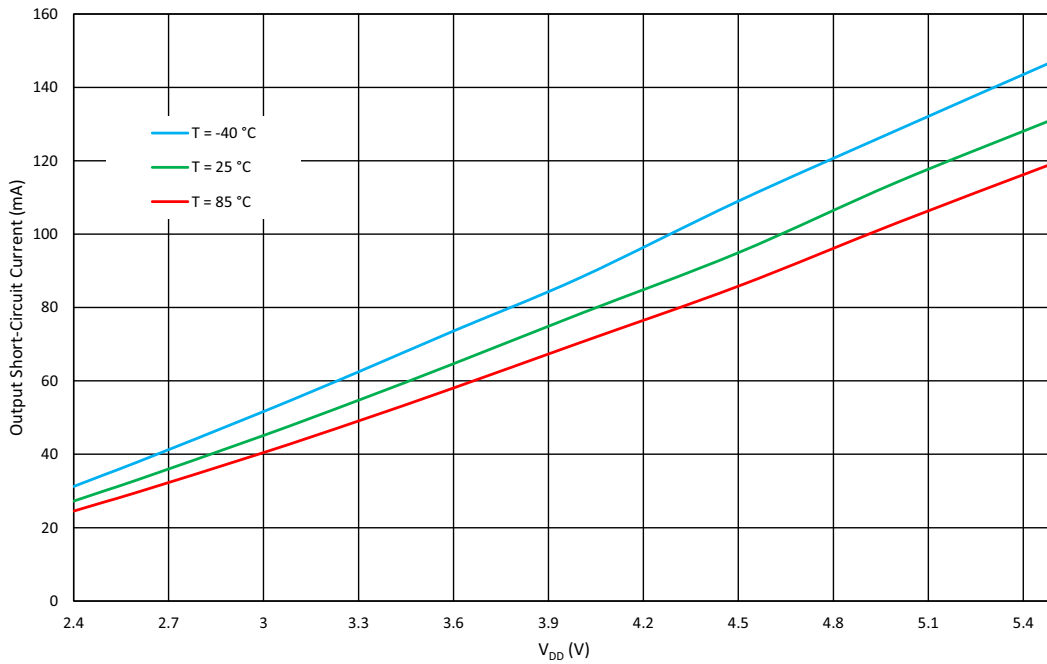

Figure 209: HD Buffer Output Short-Circuit Current vs. V_{DD}

SLG47004

GreenPAK Programmable Mixed-Signal Matrix with In-System Programmability and Advanced Analog Features

16 Clocking

16.1 OSC GENERAL DESCRIPTION

The SLG47004 has three internal oscillators to support a variety of applications:

- Oscillator0 (2.048 kHz)
- Oscillator1 (2.048 MHz)
- Oscillator2 (25 MHz)

There are two divider stages for each oscillator that give the user flexibility for introducing clock signals to connection matrix, as well as various other Macrocells. The pre-divider (first stage) for Oscillator allows the selection of /1, /2, /4, or /8 to divide down frequency from the fundamental. The second stage divider has an input of frequency from the pre-divider, and outputs one of eight different frequencies divided by /1, /2, /3, /4, /8, /12, /24, or /64 on Connection Matrix Input lines [52], [53], and [54]. Please see [Figure 213](#) for more details on the SLG47004 clock scheme.

Oscillator2 (25 MHz) has an additional function of 100 ns delayed startup, which can be enabled/disabled by register [713]. This function is recommended to use when analog blocks are used along with the Oscillator.

The Matrix Power-down/Force On function allows switching off or force on the oscillator using an external pin. The Matrix Power-down/Force On (Connection Matrix Output [91], [92], [93]) signal has the highest priority. The OSC operates according to the [Table 59](#)

It is highly recommended to force the bandgap on when OSC1 or OSC2 are used in the project.

Table 59: Oscillator Operation Mode Configuration Settings

POR	External Clock Selection	Signal From Connection Matrix	Register: Power-Down or Force On by Matrix Input	Register: Auto Power-On or Force On	OSC Enable Signal from CNT/DLY Macrocells	OSC Operation Mode
0	X	X	X	X	X	OFF
1	1	X	X	X	X	Internal OSC is OFF, logic is ON
1	0	1	0	X	X	OFF
1	0	1	1	X	X	ON
1	0	0	X	1	X	ON
1	0	0	X	0	CNT/DLY requires OSC	ON
1	0	0	X	0	CNT/DLY does not require OSC	OFF

Note 1 The OSC will run only when any macrocell that uses OSC is powered on.

SLG47004

GreenPAK Programmable Mixed-Signal Matrix with In-System Programmability and Advanced Analog Features

16.2 OSCILLATOR0 (2.048 kHz)

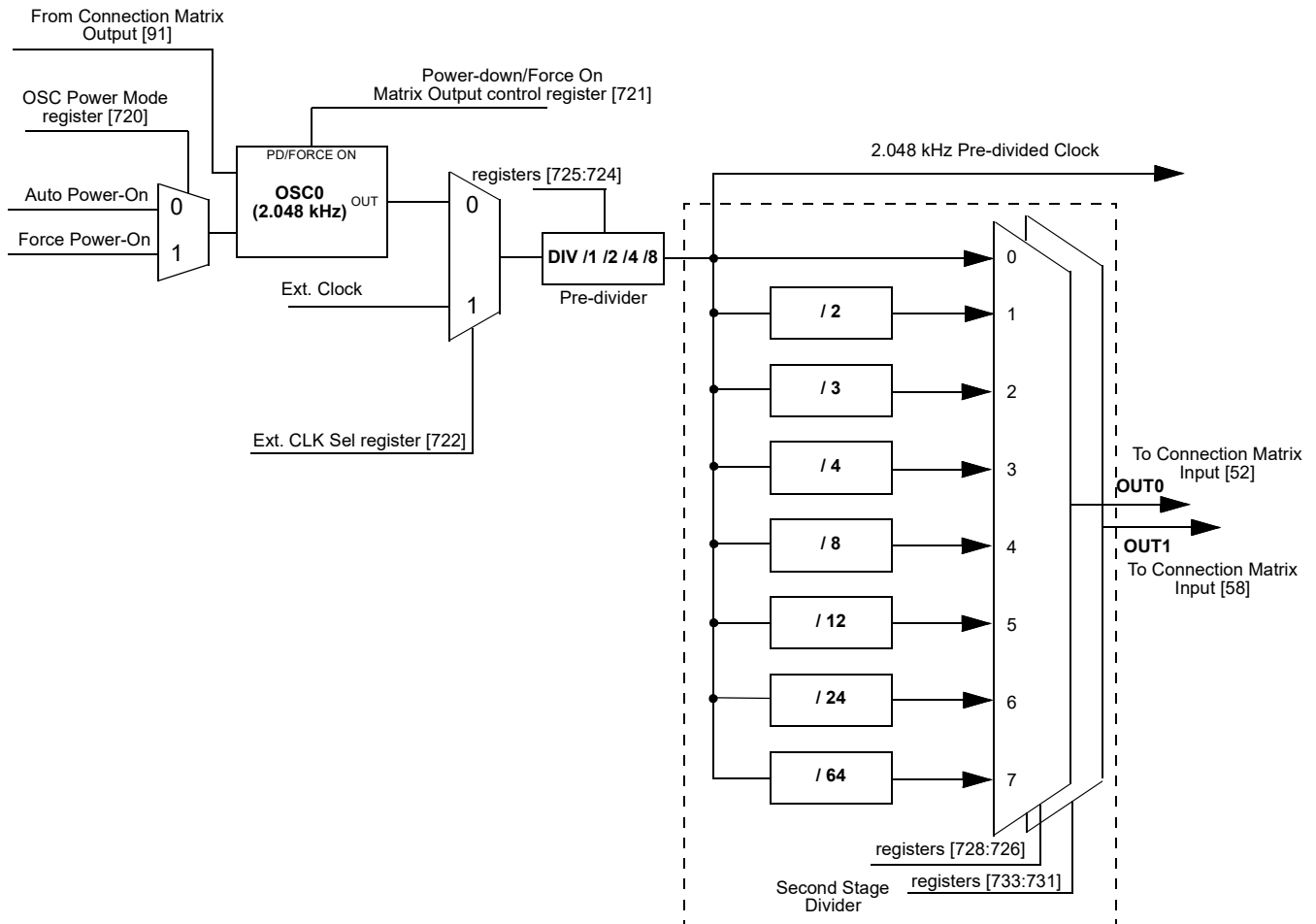

Figure 210: Oscillator0 Block Diagram

SLG47004

GreenPAK Programmable Mixed-Signal Matrix with In-System Programmability and Advanced Analog Features

16.3 OSCILLATOR1 (2.048 MHZ)

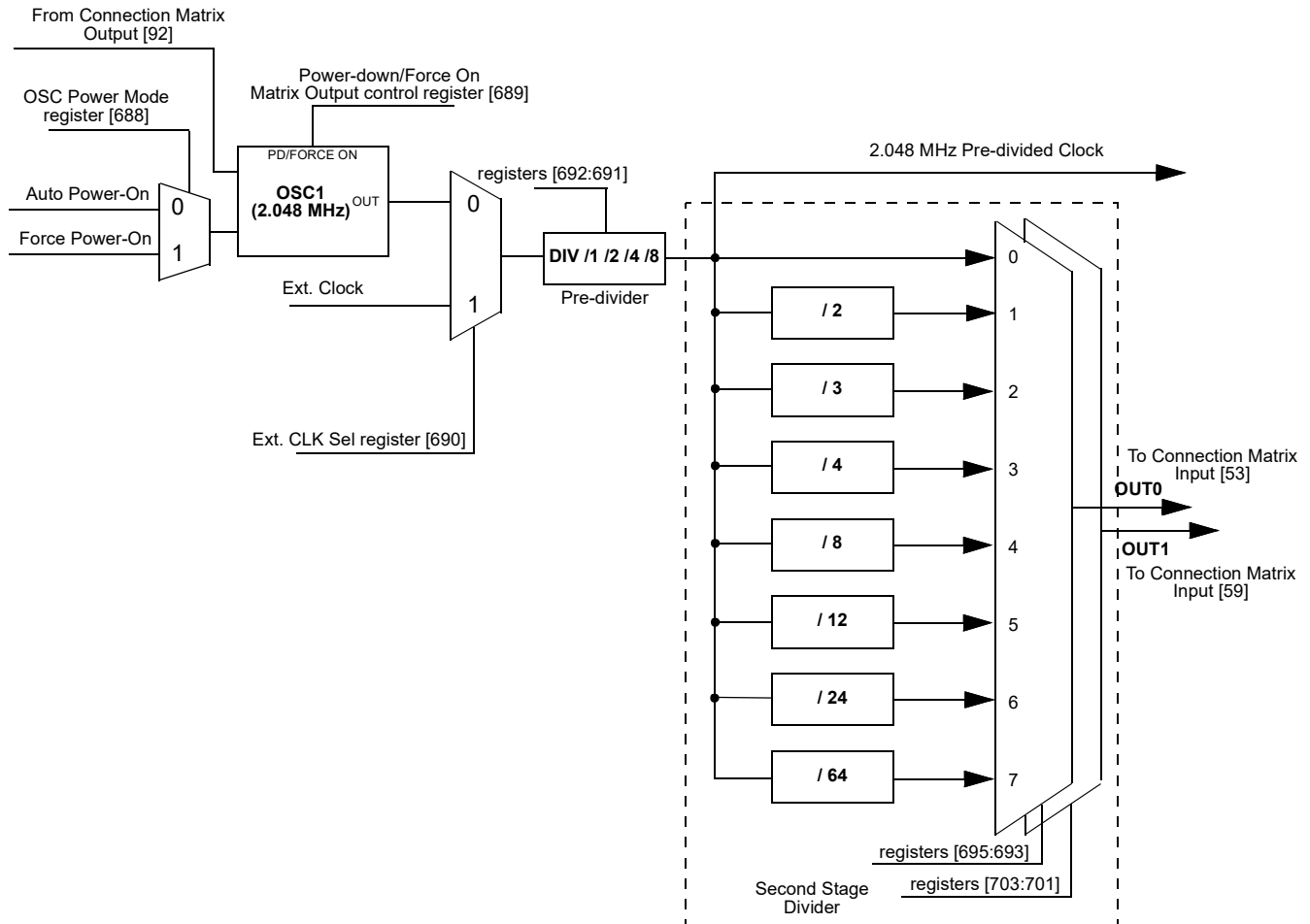

Figure 211: Oscillator1 Block Diagram

SLG47004

GreenPAK Programmable Mixed-Signal Matrix with In-System Programmability and Advanced Analog Features

16.4 OSCILLATOR2 (25 MHZ)

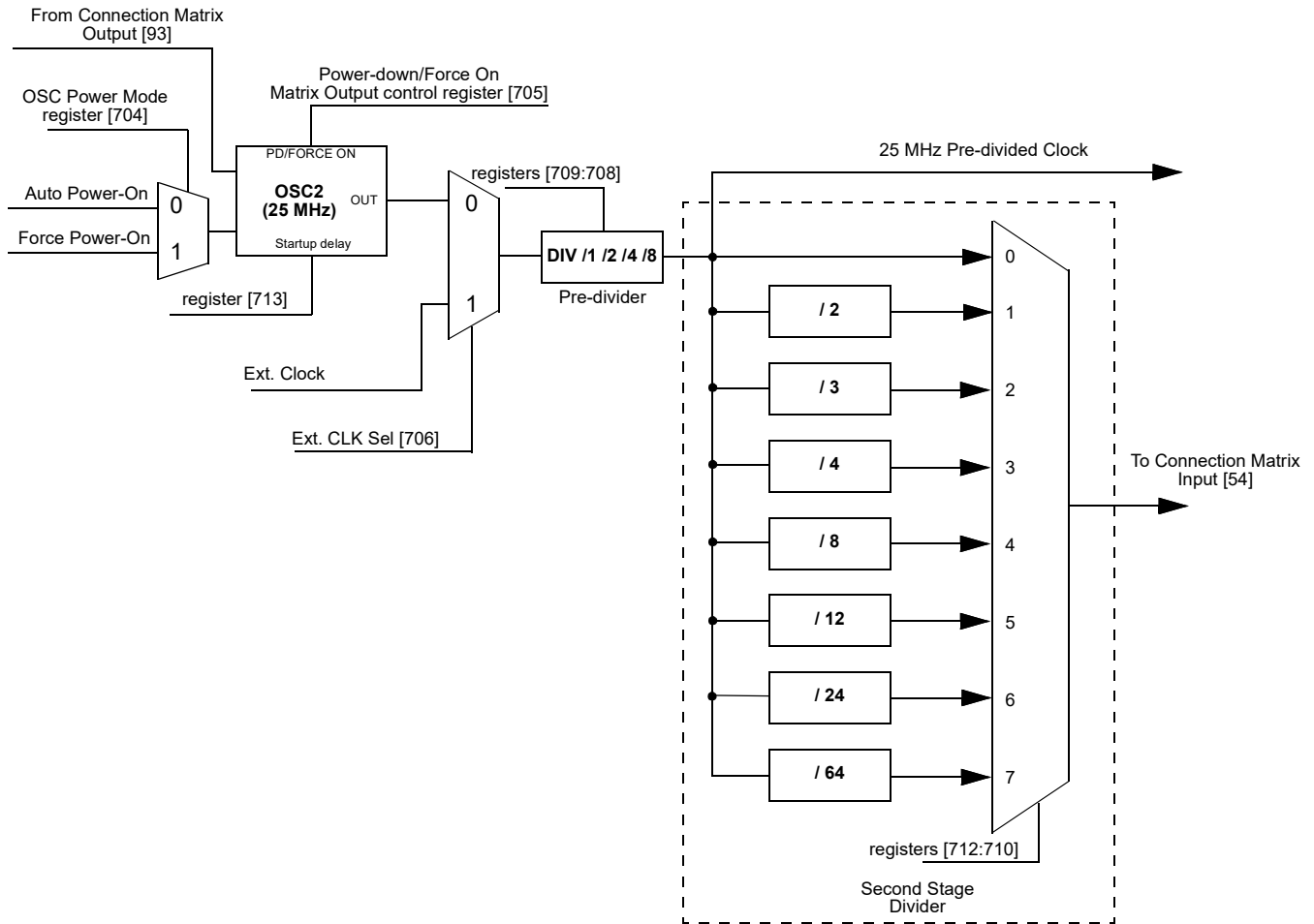

Figure 212: Oscillator2 Block Diagram

16.5 CNT/DLY CLOCK SCHEME

Each CNT/DLY within Multi-Function macrocell has its own additional clock divider connected to oscillators pre-divider. Available dividers are:

- OSC0/1, OSC0/8, OSC0/64, OSC0/512, OSC0/4096, OSC0/32768, OSC0/262144
- OSC1/1, OSC1/8, OSC1/64, OSC1/512
- OSC2/1, OSC2/4

SLG47004

GreenPAK Programmable Mixed-Signal Matrix with In-System Programmability and Advanced Analog Features

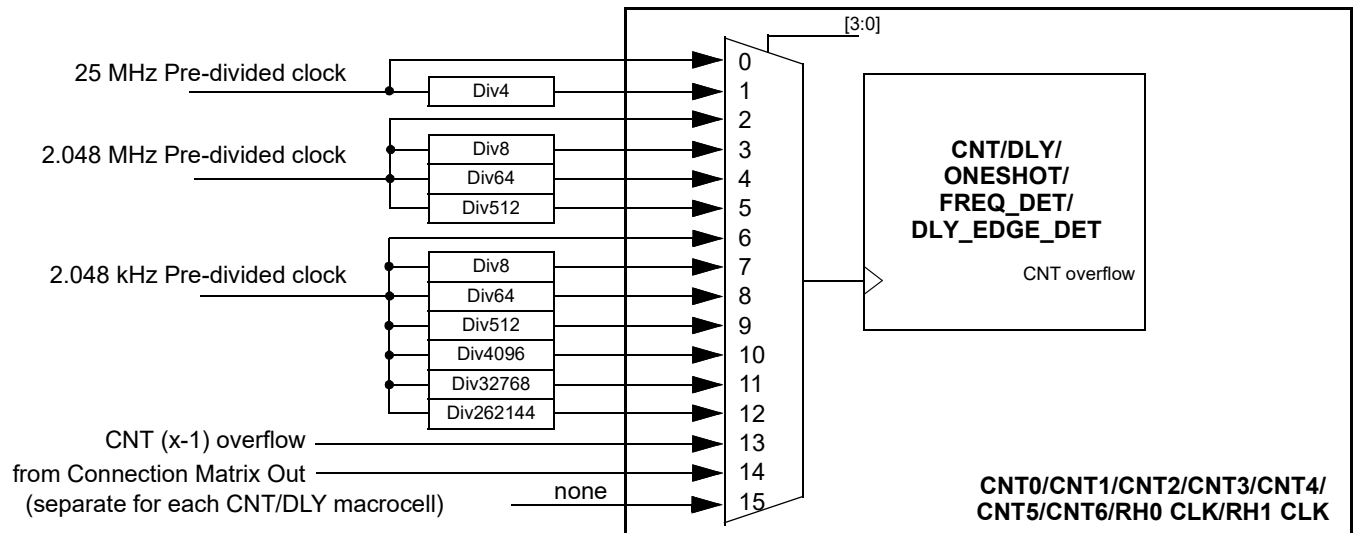

Figure 213: Clock Scheme

16.6 EXTERNAL CLOCKING

The SLG47004 supports several ways to use an external, higher accuracy clock as a reference source for internal operations.

16.6.1 IO10 Source for Oscillator0 (2.048 kHz)

When register [722] is set to 1, an external clocking signal on IO0 will be routed in place of the internal oscillator derived 2.048 kHz clock source. See Figure 210. The high and low limits for frequency that can be selected are 0 MHz and 10 MHz.

16.6.2 IO1 Source for Oscillator1 (2.048 MHz)

When register [690] is set to 1, an external clocking signal on IO1 will be routed in place of the internal oscillator derived 2.048 MHz clock source. See Figure 211. The high and low limits for frequency that can be selected are 0 MHz and 10 MHz.

16.6.3 IO2 Source for Oscillator2 (25 MHz)

When register [706] is set to 1, an external clocking signal on IO2 will be routed in place of the internal oscillator derived 25 MHz clock source. See Figure 212. The external frequency range is 0 MHz to 20 MHz at $V_{DD} = 2.4$ V, 0 MHz to 30 MHz at $V_{DD} = 3.3$ V, 0 MHz to 50 MHz at $V_{DD} = 5.0$ V. When an external clock is selected for OSC2, the oscillator's output signal will be inverted with respect to the IO2 input signal.

SLG47004

GreenPAK Programmable Mixed-Signal Matrix with In-System Programmability and Advanced Analog Features

16.7 OSCILLATORS POWER-ON DELAY

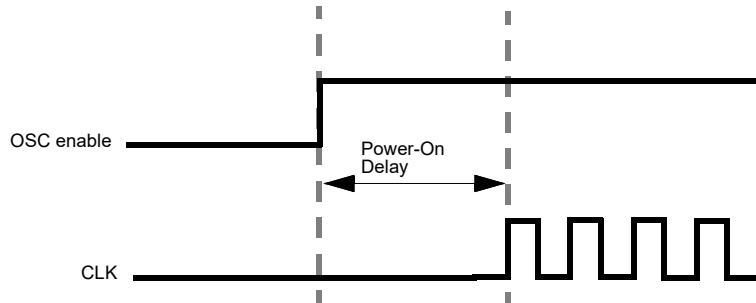

Figure 214: Oscillator Startup Diagram

Note 1 OSC power mode: “Auto Power-On”.

Note 2 “OSC enable” signal appears when any macrocell that uses OSC is powered on

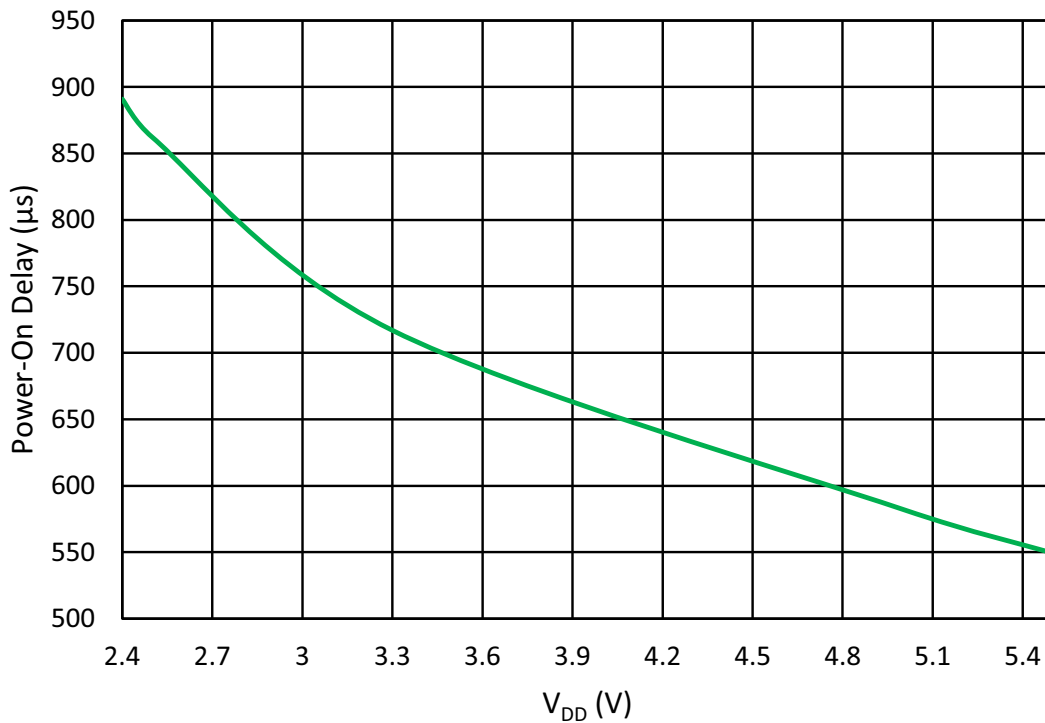

Figure 215: OSC0 Maximum Power-On Delay vs. V_{DD} at T = 25 °C, OSC0 = 2.048 kHz

SLG47004

GreenPAK Programmable Mixed-Signal Matrix
with In-System Programmability and Advanced Analog Features

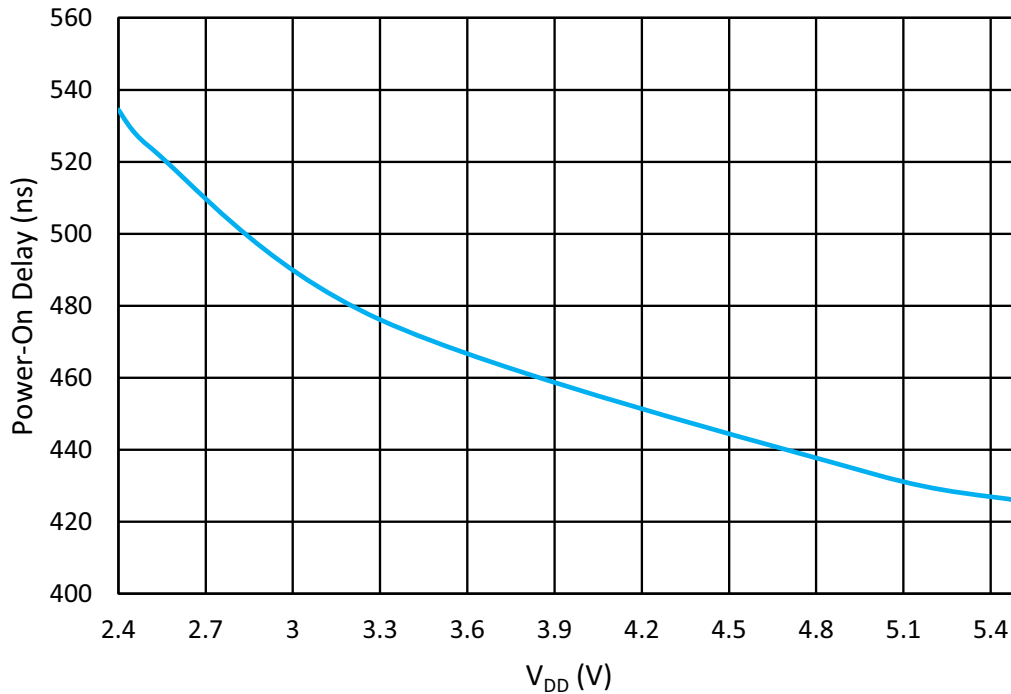

Figure 216: OSC1 Oscillator Maximum Power-On Delay vs. V_{DD} at T = 25 °C, OSC1 = 2.048 MHz

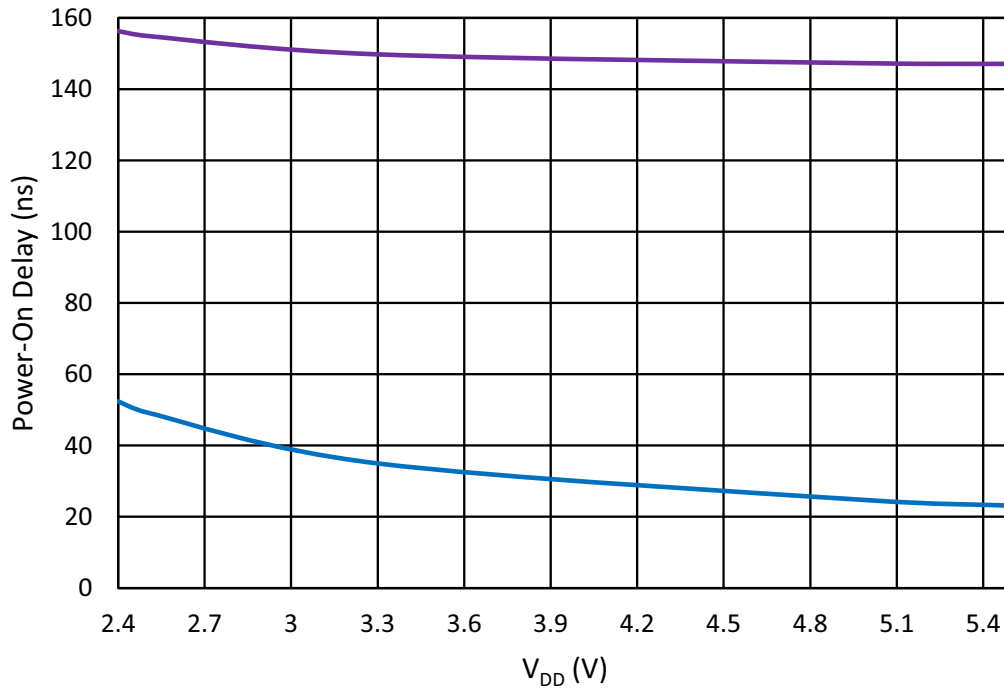

Figure 217: OSC2 Maximum Power-On Delay vs. V_{DD} at T = 25 °C, OSC2 = 25 MHz

SLG47004

GreenPAK Programmable Mixed-Signal Matrix with In-System Programmability and Advanced Analog Features

16.8 OSCILLATORS ACCURACY

Note: OSC power setting: Force Power-On; Clock to matrix input - enable; Bandgap: turn on by register - enable.

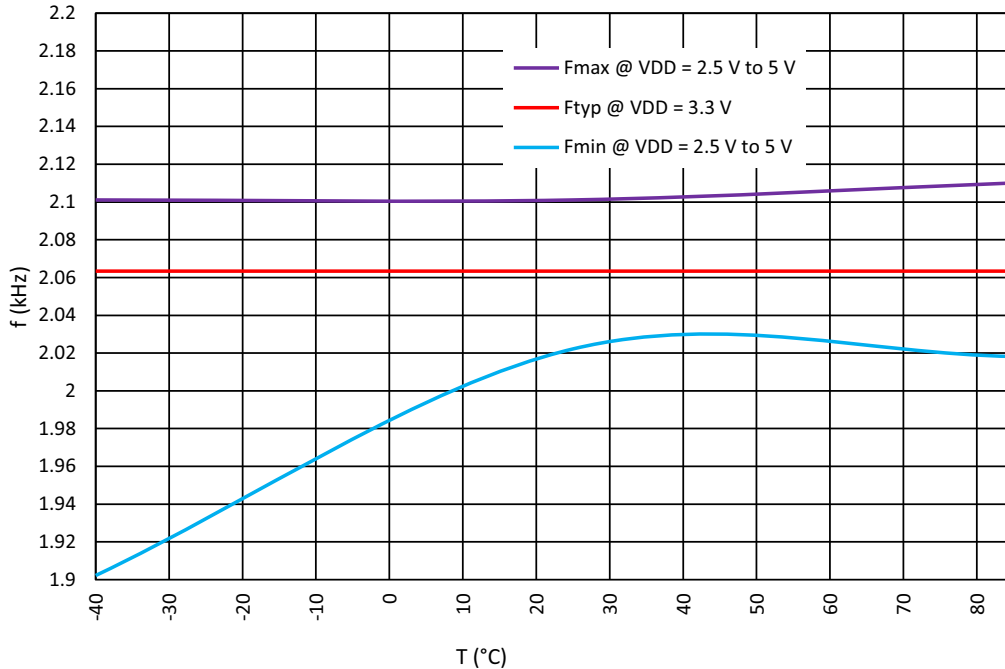

Figure 218: OSC0 Frequency vs. Temperature, OSC0 = 2.048 kHz

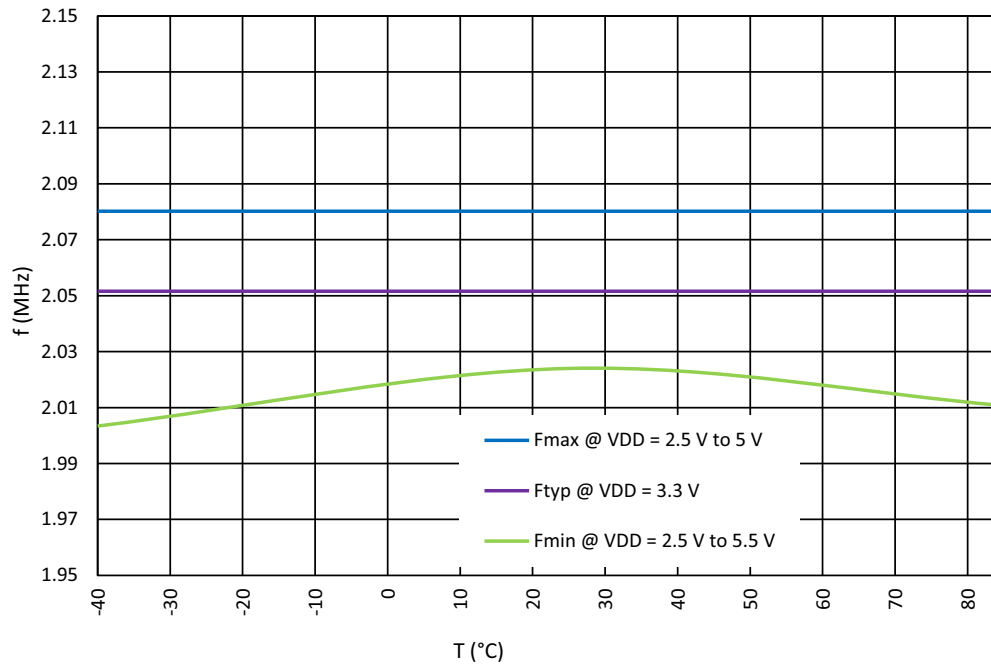

Figure 219: OSC1 Frequency vs. Temperature, OSC1 = 2.048 MHz

SLG47004

GreenPAK Programmable Mixed-Signal Matrix
with In-System Programmability and Advanced Analog Features

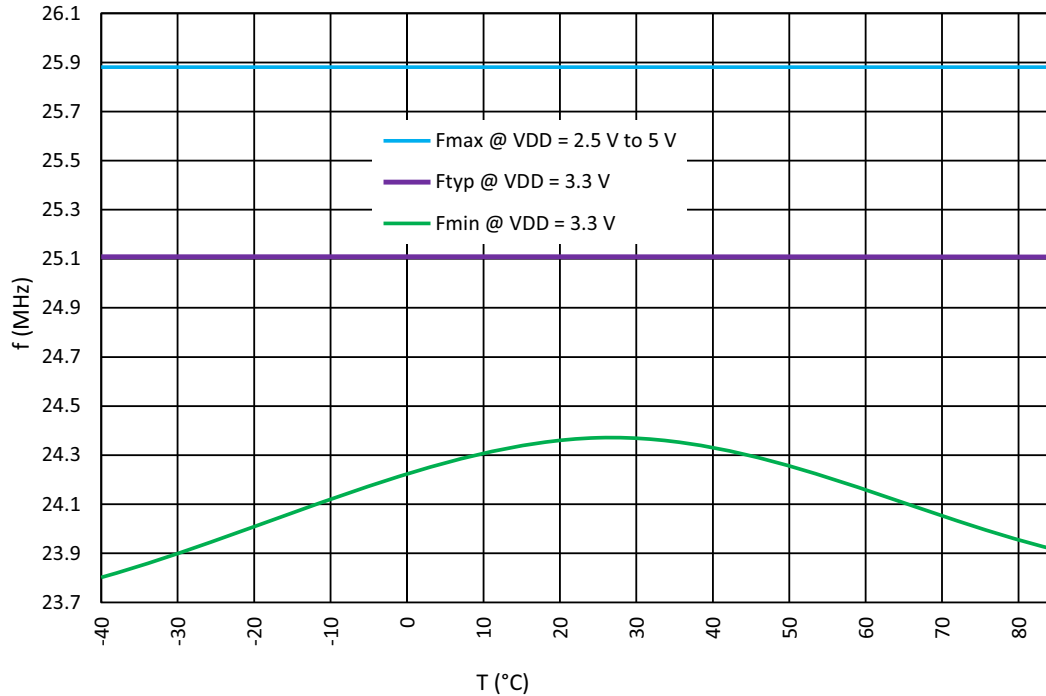

Figure 220: OSC2 Frequency vs. Temperature, OSC2 = 25 MHz

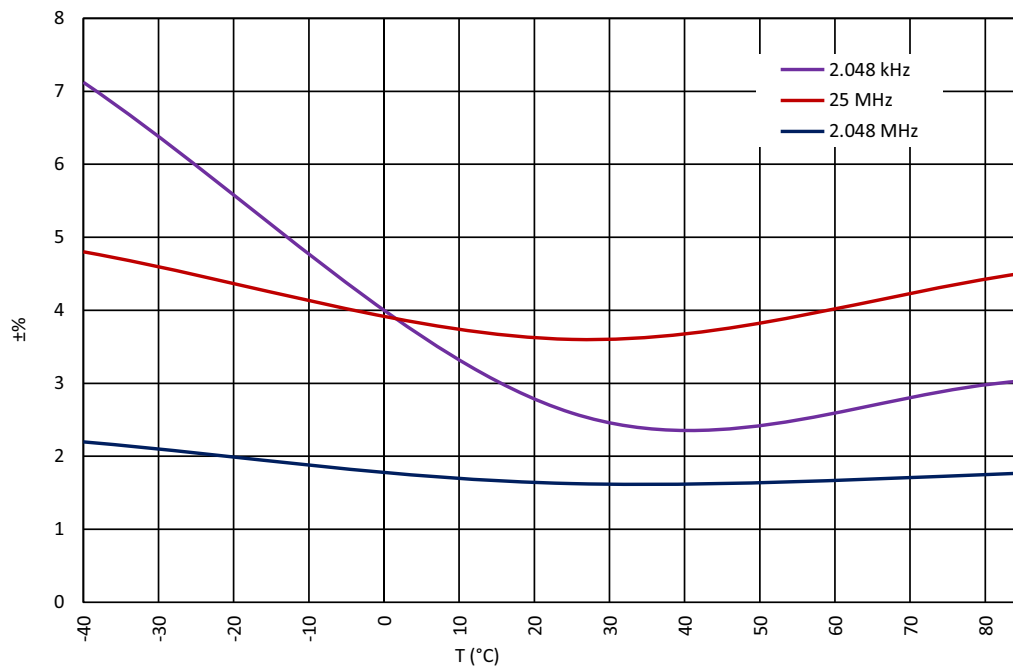

Figure 221: Oscillators Total Error vs. Temperature at V_{DD} = 2.4 V to 5.5 V

SLG47004

GreenPAK Programmable Mixed-Signal Matrix with In-System Programmability and Advanced Analog Features

Note: For more information see Section 3.8.

16.9 OSCILLATORS SETTLING TIME

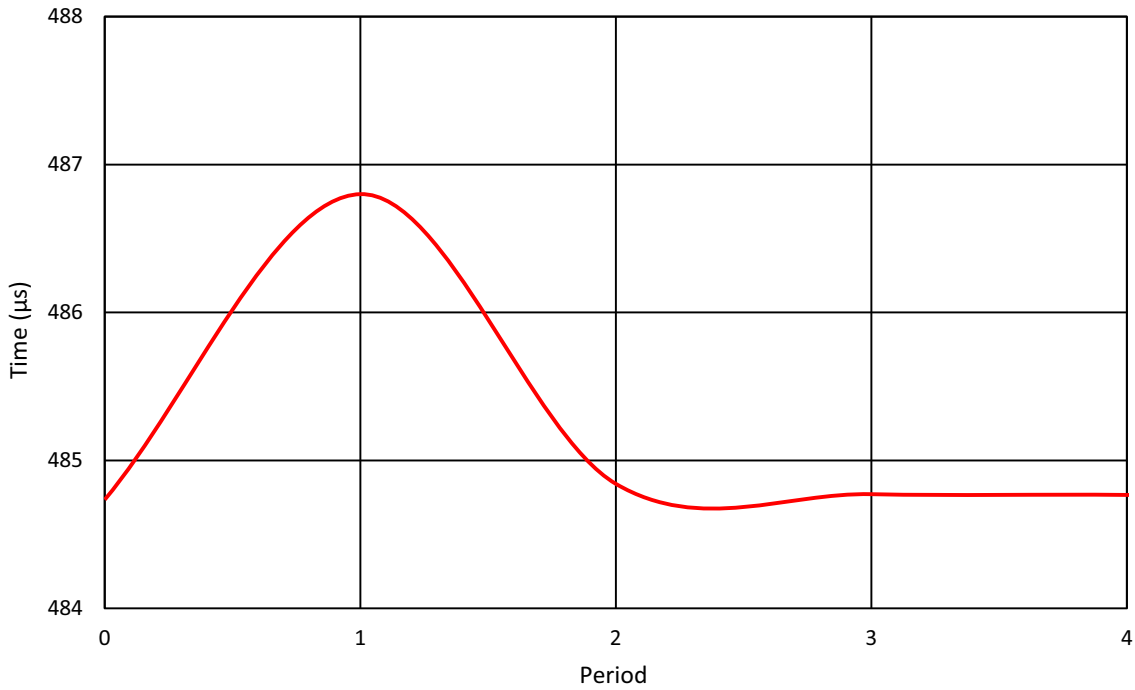

Figure 222: Oscillator0 Settling Time, $V_{DD} = 3.3\text{ V}$, $T = 25\text{ }^{\circ}\text{C}$, $\text{OSC0} = 2\text{ kHz}$

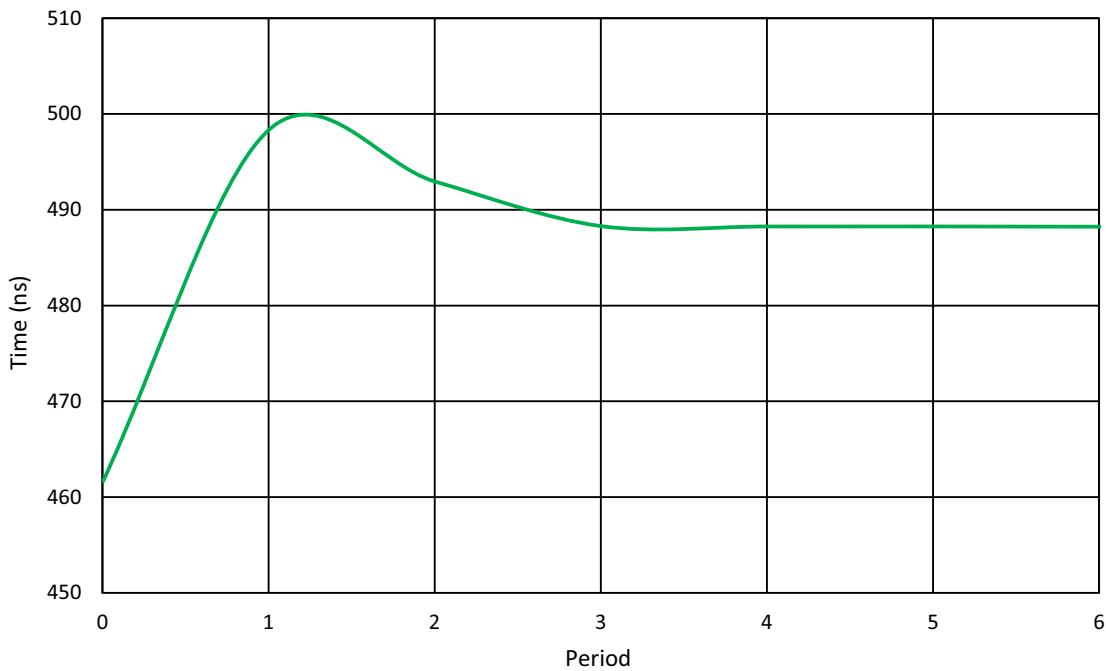

Figure 223: Oscillator1 Settling Time, $V_{DD} = 3.3\text{ V}$, $T = 25\text{ }^{\circ}\text{C}$, $\text{OSC1} = 2\text{ MHz}$

SLG47004

GreenPAK Programmable Mixed-Signal Matrix
with In-System Programmability and Advanced Analog Features

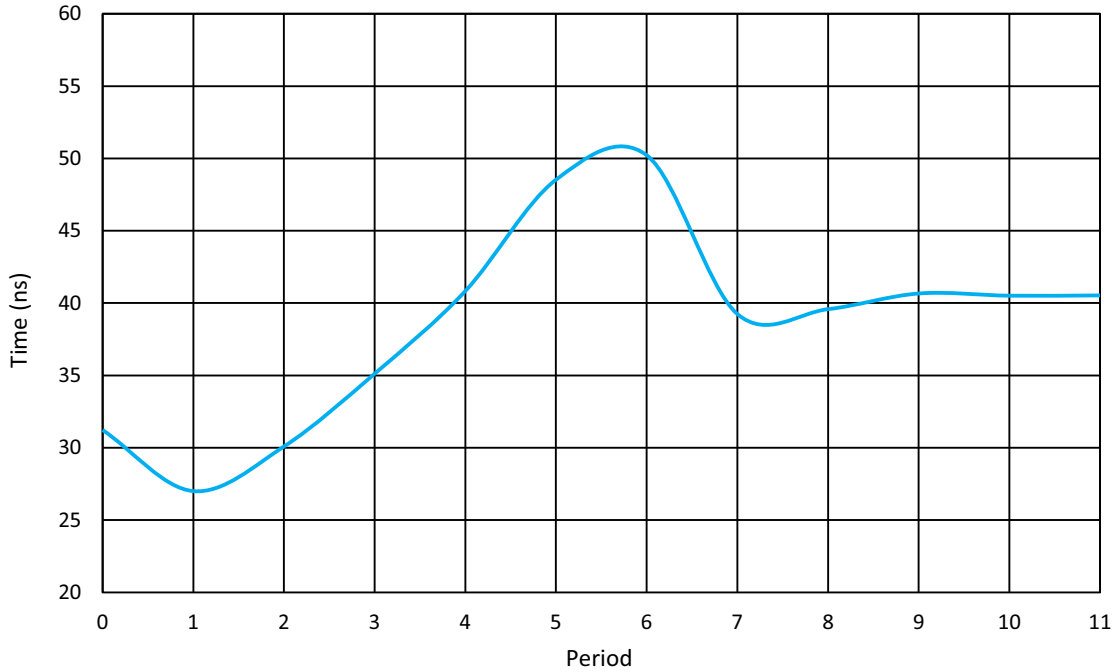

Figure 224: Oscillator2 Settling Time, $V_{DD} = 3.3\text{ V}$, $T = 25\text{ }^\circ\text{C}$, $\text{OSC2} = 25\text{ MHz}$ (Normal Start)

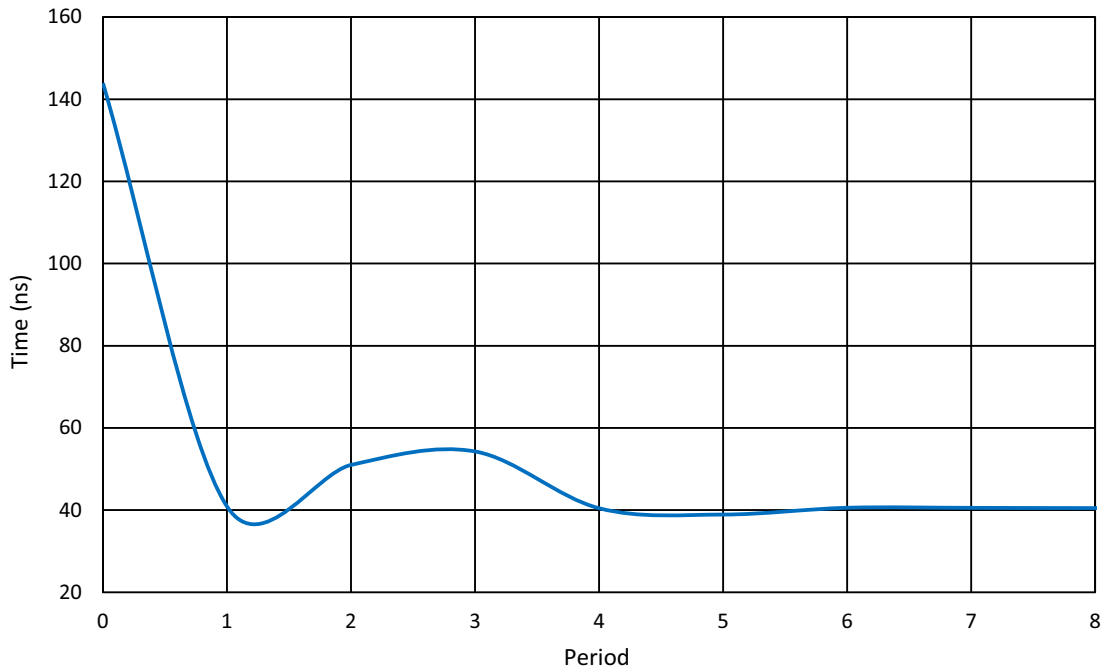

Figure 225: Oscillator2 Settling Time, $V_{DD} = 3.3\text{ V}$, $T = 25\text{ }^\circ\text{C}$, $\text{OSC2} = 25\text{ MHz}$ (Start with Delay)

SLG47004

GreenPAK Programmable Mixed-Signal Matrix
with In-System Programmability and Advanced Analog Features

16.10 OSCILLATORS CURRENT CONSUMPTION

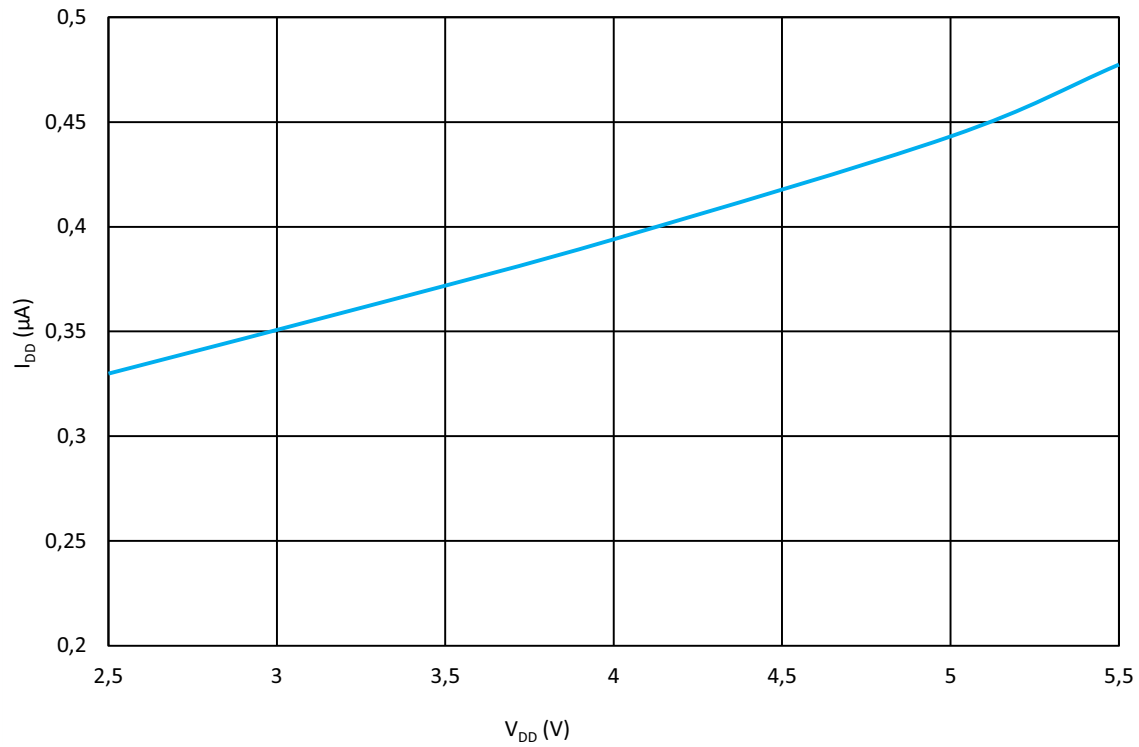

Figure 226: OSC0 Current Consumption vs. V_{DD} at T = -40 °C to +85 °C (All Pre-Dividers)

SLG47004

GreenPAK Programmable Mixed-Signal Matrix
with In-System Programmability and Advanced Analog Features

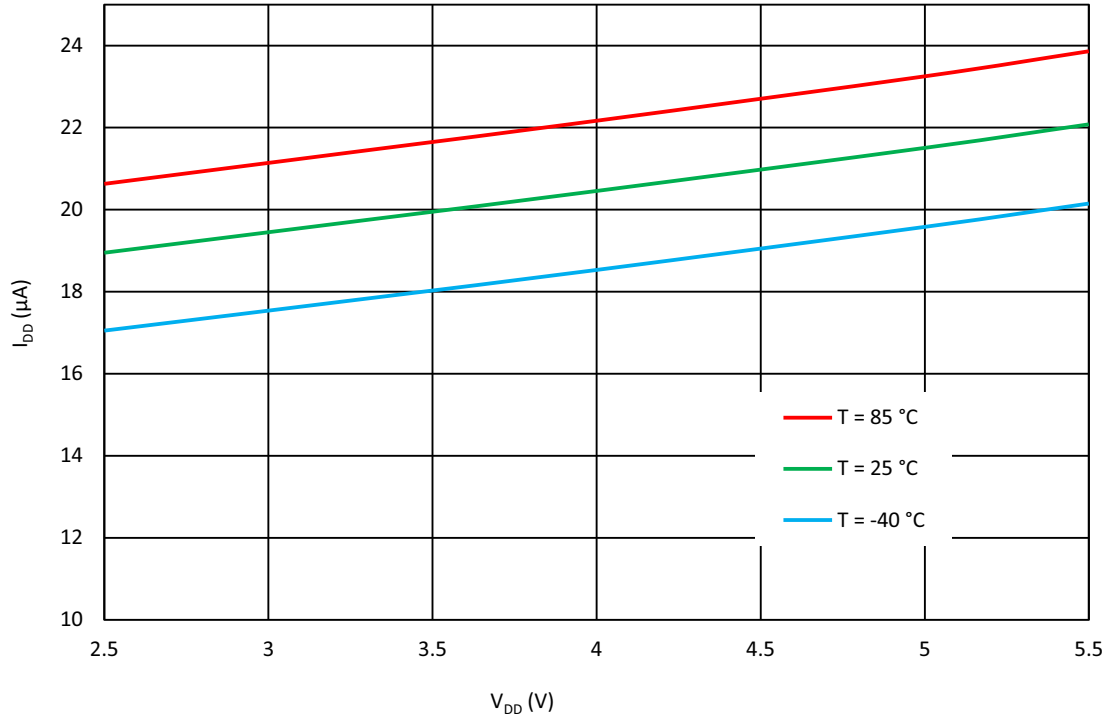

Figure 227: OSC1 Current Consumption vs. V_{DD} (Pre-Divider = 1)

SLG47004

GreenPAK Programmable Mixed-Signal Matrix
with In-System Programmability and Advanced Analog Features

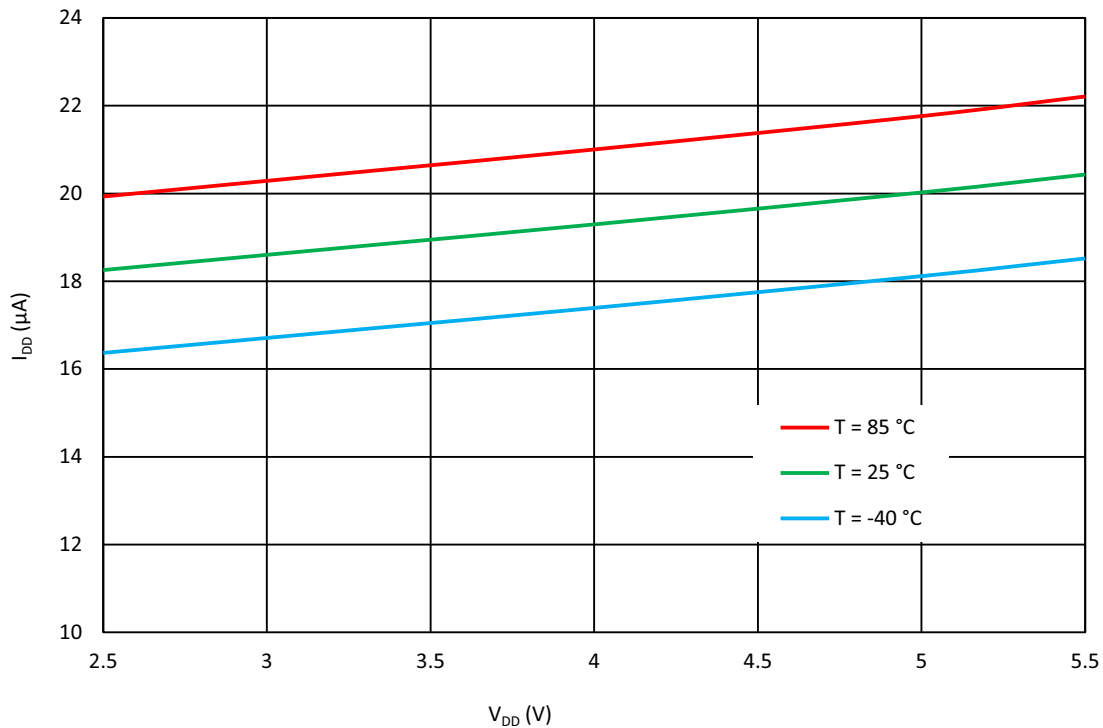

Figure 228: OSC1 Current Consumption vs. V_{DD} (Pre-Divider = 4)

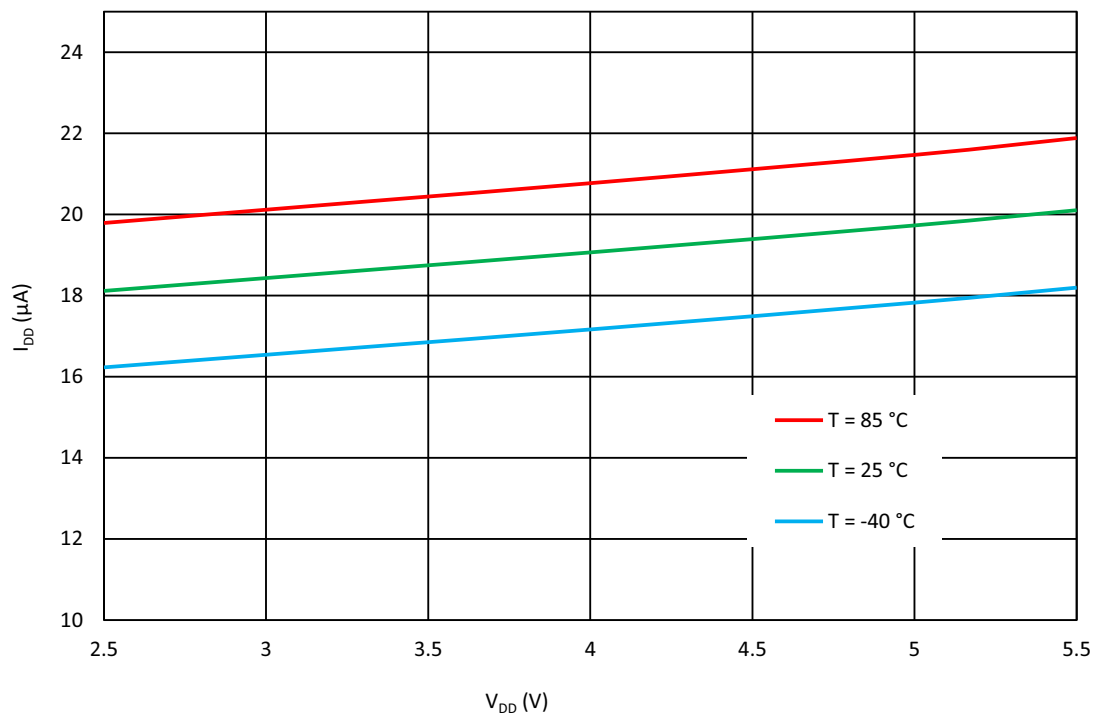

Figure 229: OSC1 Current Consumption vs. V_{DD} (Pre-Divider = 8)

SLG47004

GreenPAK Programmable Mixed-Signal Matrix
with In-System Programmability and Advanced Analog Features

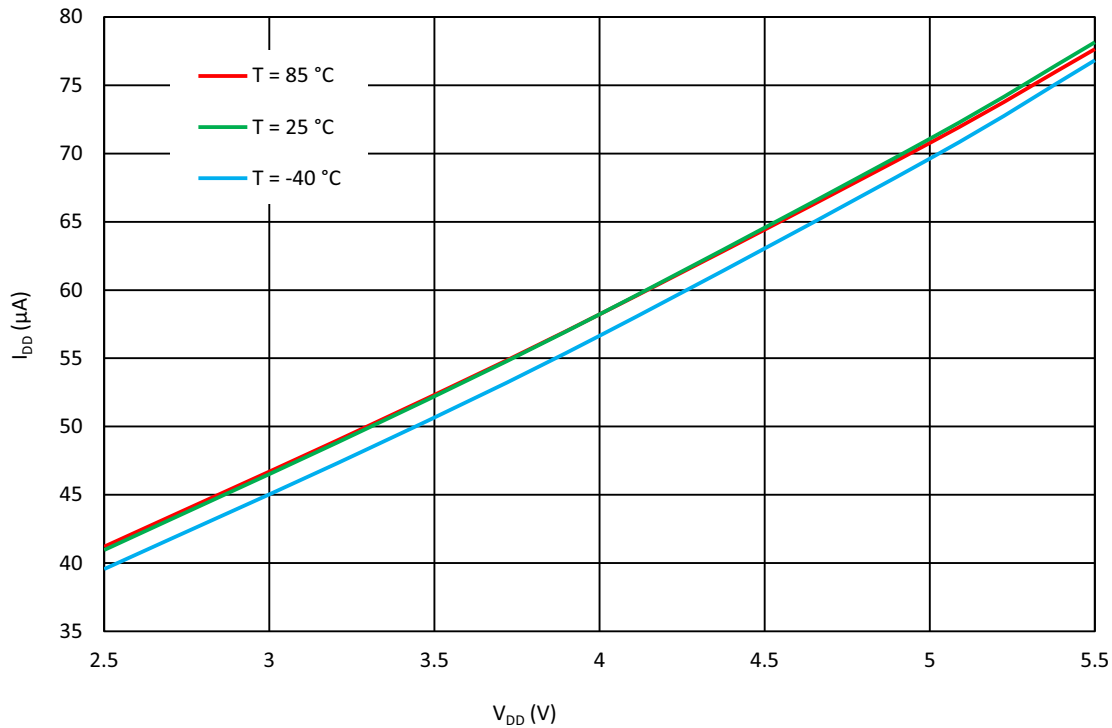

Figure 230: OSC2 Current Consumption vs. V_{DD} (Pre-Divider = 1)

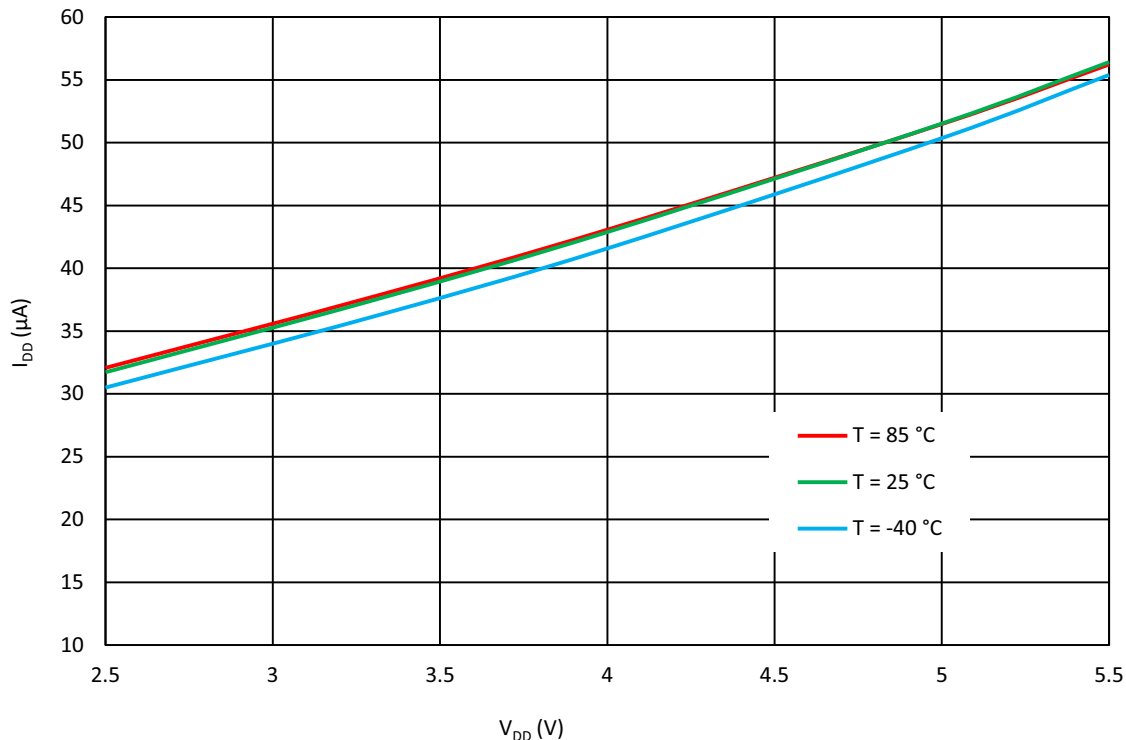

Figure 231: OSC2 Current Consumption vs. V_{DD} (Pre-Divider = 4)

SLG47004

GreenPAK Programmable Mixed-Signal Matrix
with In-System Programmability and Advanced Analog Features

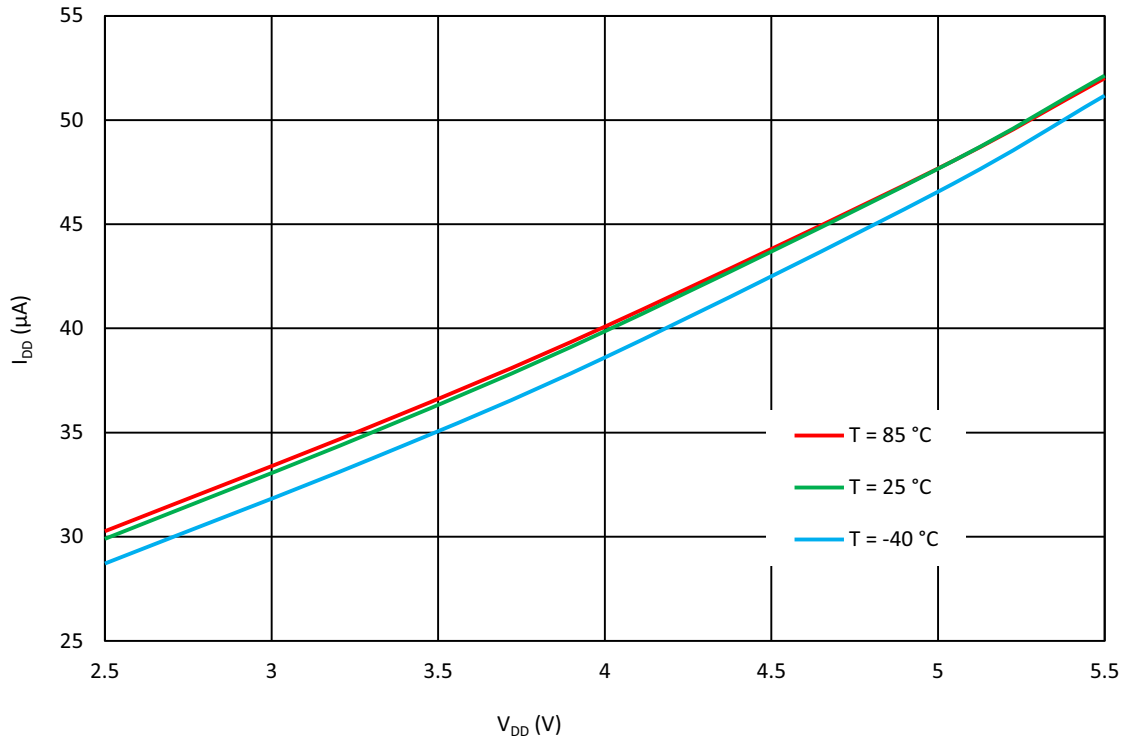

Figure 232: OSC2 Current Consumption vs. V_{DD} (Pre-Divider = 8)

SLG47004

GreenPAK Programmable Mixed-Signal Matrix with In-System Programmability and Advanced Analog Features

17 Power-On Reset

The SLG47004 has a Power-On Reset (POR) macrocell to ensure correct device initialization and operation of all macrocells in the device. The purpose of the POR circuit is to have consistent behavior and predictable results when the V_{DD} power is first ramping to the device, and also while the V_{DD} is falling during Power-down. To accomplish this goal, the POR drives a defined sequence of internal events that trigger changes to the states of different macrocells inside the device, and finally to the state of the IOs.

17.1 GENERAL OPERATION

The SLG47004 is guaranteed to be powered down and non-operational when the V_{DD} voltage (voltage on PIN13) is less than Power-Off Threshold (see in [Table 6](#)), but not less than -0.6 V. Another essential condition for the chip to be powered down is that no voltage higher (Note) than the V_{DD} voltage is applied to any other PIN. For example, if V_{DD} voltage is 0.3 V, applying a voltage higher than 0.3 V to any other PIN is incorrect, and can lead to incorrect or unexpected device behavior.

Note: There is a 0.6 V margin due to forward drop voltage of the ESD protection diodes.

To start the POR sequence in the SLG47004, the voltage applied on the V_{DD} should be higher than the Power-On Threshold (Note). The full operational V_{DD} range for the SLG47004 is 2.4 V to 5.5 V. This means that the V_{DD} voltage must ramp up to the operational voltage value, but the POR sequence will start earlier, as soon as the V_{DD} voltage rises to the Power-On Threshold. After the POR sequence has started, the SLG47004 will have a typical Startup Time (see in [Table 6](#)) to go through all the steps in the sequence, and will be ready and completely operational after the POR sequence is complete.

Note: The Power-On Threshold is defined in [Table 6](#).

To power down the chip, the V_{DD} voltage should be lower than the operational and to guarantee that chip is powered down, it should be less than Power-Off Threshold.

All PINs are in high impedance state when the chip is powered down and while the POR sequence is taking place. The last step in the POR sequence releases the IO structures from the high impedance state, at which time the device is operational. The pin configuration at this point in time is defined by the design programmed into the chip. Also, as it was mentioned before, the voltage on PINs can't be bigger than the V_{DD} , this rule also applies to the case when the chip is powered on.

SLG47004

GreenPAK Programmable Mixed-Signal Matrix with In-System Programmability and Advanced Analog Features

17.2 POR SEQUENCE

The POR system generates a sequence of signals that enable certain macrocells. The sequence is shown in [Figure 233](#).

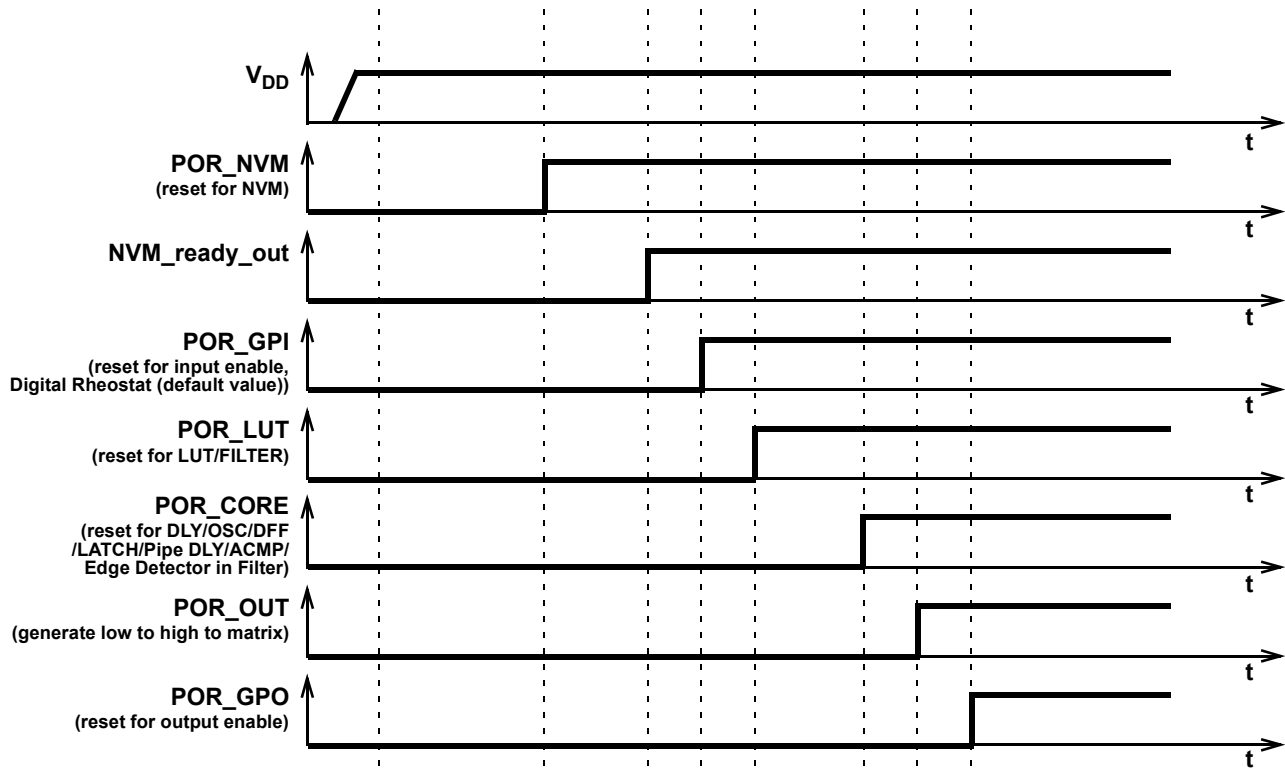

Figure 233: POR Sequence

As can be seen from [Figure 233](#) after the V_{DD} has started ramping up and crossed the Power-On Threshold, first, the on-chip NVM memory is reset. Next, the chip reads the data from NVM and transfers this information to a CMOS LATCH, that serves to configure each macrocell, and the Connection Matrix, which routes signals between macrocells. The third stage causes the reset of the input pins, and then enables them. At that time Digital Rheostats value is set to its default value. After that, the LUTs are reset and become active. After LUTs, the Delay cells, OSCs, DFFs, LATCHES, and Pipe Delay are initialized. Only after all macrocells are initialized, internal POR signal (POR macrocell output) goes from LOW to HIGH (POR_OUT in [Figure 233](#)). The last portion of the device to be initialized is the output pins, which transition from high impedance to active at this point.

The typical time that takes to complete the POR sequence varies by device type in the GreenPAK family. It also depends on many environmental factors, such as: slew rate, V_{DD} value, temperature, and even will vary from chip to chip (process influence).

17.3 MACROCELLS OUTPUT STATES DURING POR SEQUENCE

To have a full picture of SLG47004 operation during powering and POR sequence refer to [Figure 234](#), which describes the macrocell output states during the POR sequence.

First, before the NVM has been reset, all macrocells have their output set to logic LOW (except the output pins which are in high impedance state). On the next step, some of the macrocells start initialization: input pins output state becomes LOW; Digital Rheostats value is set to its default value; LUTs also output LOW. After that input pins are enabled. Next, only LUTs are configured. Then, all other macrocells are initialized. After macrocells are initialized, internal POR matrix signal switches from LOW to HIGH. The last are output pins that become active and determined by the input signals.

SLG47004

GreenPAK Programmable Mixed-Signal Matrix with In-System Programmability and Advanced Analog Features

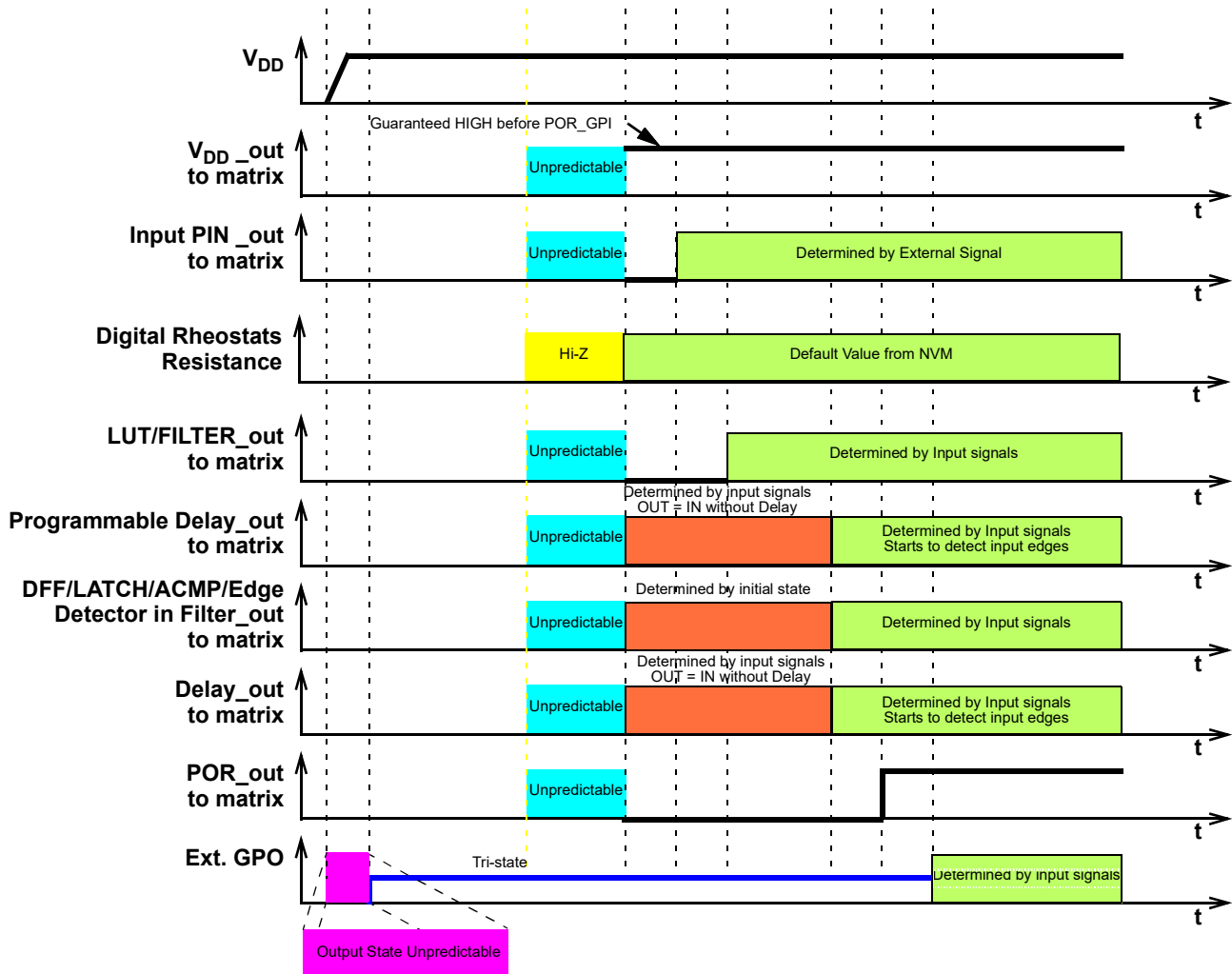

Figure 234: Internal Macrocell States During POR Sequence

17.3.1 Initialization

All internal macrocells by default have initial low level. Starting from indicated power-up time of 1.63 V to 2.04 V, macrocells in SLG47004 are powered on while forced to the reset state. All outputs are in Hi-Z and chip starts loading data from NVM. Then the reset signal is released for internal macrocells and they start to initialize according to the following sequence:

1. Input pins, Pull-up/down, Digital Rheostats, Op Amps.
2. LUTs.
3. DFFs, Delays/Counters, Pipe Delay, OSCs, ACMPs.
4. POR output to matrix.
5. Output pin corresponds to the internal logic.

The Vref output pin driving signal can precede POR output signal going high by 3 μs to 5 μs. The POR signal going high indicates the mentioned power-up sequence is complete.

Note: The maximum voltage applied to any pin should not be higher than the V_{DD} level. There are ESD Diodes between pin →

SLG47004

GreenPAK Programmable Mixed-Signal Matrix with In-System Programmability and Advanced Analog Features

V_{DD} and pin \rightarrow GND on each pin. Exceeding V_{DD} results in leakage current on the input pin, and V_{DD} will be pulled up, following the voltage on the input pin.

17.3.2 Power-Down

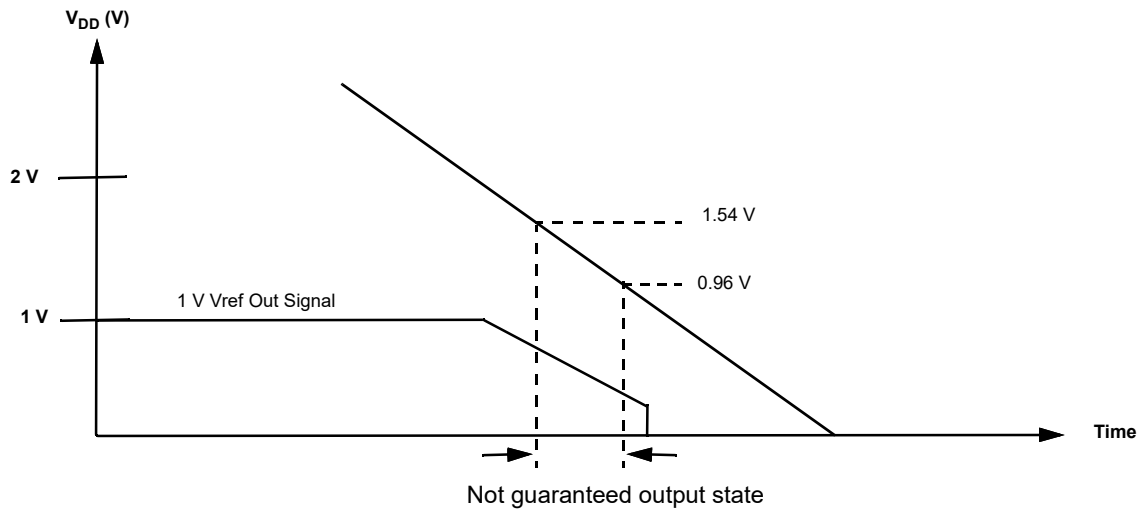

Figure 235: Power-Down

During Power-down macrocells in SLG47004 are powered off after V_{DD} falling down below Power-Off Threshold. Please note, that during a slow rampdown outputs can possibly switch state.

18 I²C Serial Communications Macrocell

18.1 I²C SERIAL COMMUNICATIONS MACROCELL OVERVIEW

In the standard use case for the GreenPAK devices, the configuration choices made by the user are stored as bit settings in the Non-Volatile Memory (NVM), and this information is transferred at startup time to volatile RAM registers that enable the configuration of the macrocells. Other RAM registers in the device are responsible for setting the connections in the Connection Matrix to route signals in the manner most appropriate for the user's application.

The I²C Serial Communications Macrocell in this device allows an I²C bus Master to read and write this information via a serial channel directly to the RAM registers, allowing the remote re-configuration of macrocells, and remote changes to signal chains within the device.

The I²C bus Master is also able to read and write other register bits that are not associated with NVM memory. As an example, the input lines to the Connection Matrix can be read as digital register bits. These are the signal outputs of each of the macrocells in the device, giving the I²C bus Master the capability to remotely read the current value of any macrocell.

The user has the flexibility to control read access and write access via registers bits registers [1795:1792]. See Section 19 for more details on I²C read/write memory protection.

18.2 I²C SERIAL COMMUNICATIONS DEVICE ADDRESSING

Each command to the I²C Serial Communications macrocell begins with a Control Byte. The bits inside this Control Byte are shown in Figure 236. After the Start bit, the first four bits are a control code. Each bit in a control code can be sourced independently from the register or by value defined externally by IO1, IO2, IO3, and IO4. The LSB of the control code is defined by the value of IO1, while the MSB is defined by the value of IO4. The address source (either register bit or PIN) for each bit in the control code is defined by registers [1019:1016]. This gives the user flexibility on the chip level addressing of this device and other devices on the same I²C bus. The default control code is 0001. The Block Address is the next three bits (A10, A9, A8), which will define the most significant bits in the addressing of the data to be read or written by the command. The last bit in the Control Byte is the R/W bit, which selects whether a read command or write command is requested, with a "1" selecting for a Read command, and a "0" selecting for a Write command. This Control Byte will be followed by an Acknowledge bit (ACK), which is sent by this device to indicate successful communication of the Control Byte data.

In the I²C-bus specification and user manual there are two groups of eight addresses (0000 xxx and 1111 xxx) that are reserved for the special functions, such as a system General Call address. If the user of this device chooses to set the Control Code to either "1111" or "0000" in a system with other slave device, please consult the I²C-bus specification and user manual to understand the addressing and implementation of these special functions, to ensure reliable operation.

In the read and write command address structure, there are a total of 11 bits of addressing, each pointing to a unique byte of information, resulting in a total address space of 2K bytes. The valid addresses are shown in the memory map in Figure 246.

With the exception of the Current Address Read command, all commands will have the Control Byte followed by the Word Address.

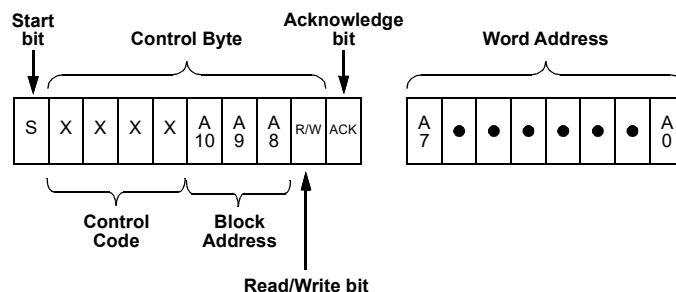

Figure 236: Basic Command Structure

SLG47004

GreenPAK Programmable Mixed-Signal Matrix with In-System Programmability and Advanced Analog Features

18.3 I²C SERIAL GENERAL TIMING

General timing characteristics for the I²C Serial Communications macrocell are shown in Figure 237. Timing specifications can be found in the AC Characteristics, section 3.4.

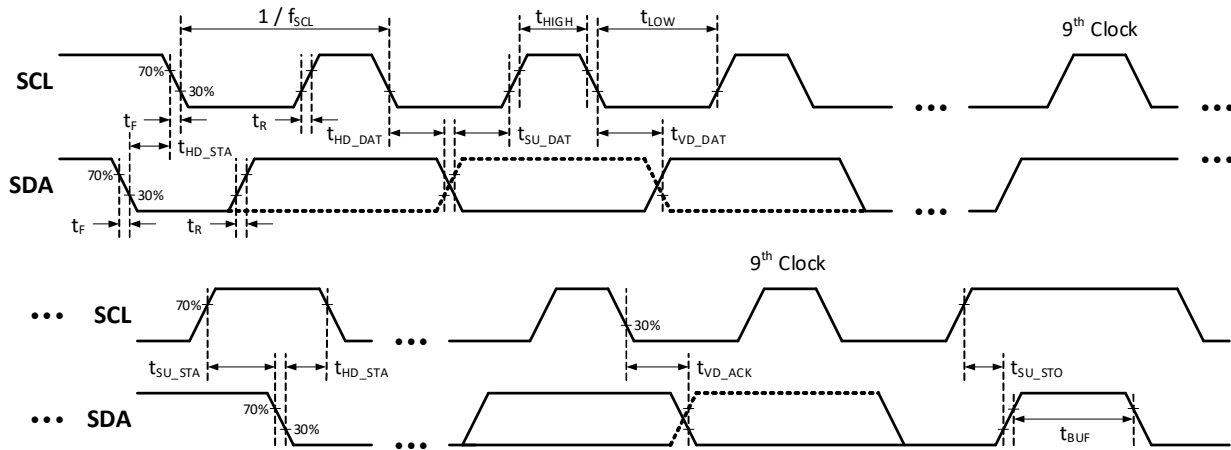

Figure 237: I²C General Timing Characteristics

18.4 I²C SERIAL COMMUNICATIONS COMMANDS

18.4.1 Byte Write Command

Following the Start condition from the Master, the Control Code [4 bits], the Block Address [3 bits], and the R/W bit (set to “0”) are placed onto the I²C bus by the Master. After the SLG47004 sends an Acknowledge bit (ACK), the next byte transmitted by the Master is the Word Address. The Block Address (A10, A9, A8), combined with the Word Address (A7 through A0), together set the internal address pointer in the SLG47004, where the data byte is to be written. After the SLG47004 sends another Acknowledge bit, the Master will transmit the data byte to be written into the addressed memory location. The SLG47004 again provides an Acknowledge bit and then the Master generates a Stop condition. The internal write cycle for the data will take place at the time that the SLG47004 generates the Acknowledge bit.

It is possible to latch all IOs during I²C write command to the register configuration data (block address A10, A9, A8 = 000), register [985] = 1 - Enable. It means that IOs will remain their state until the write command is done.

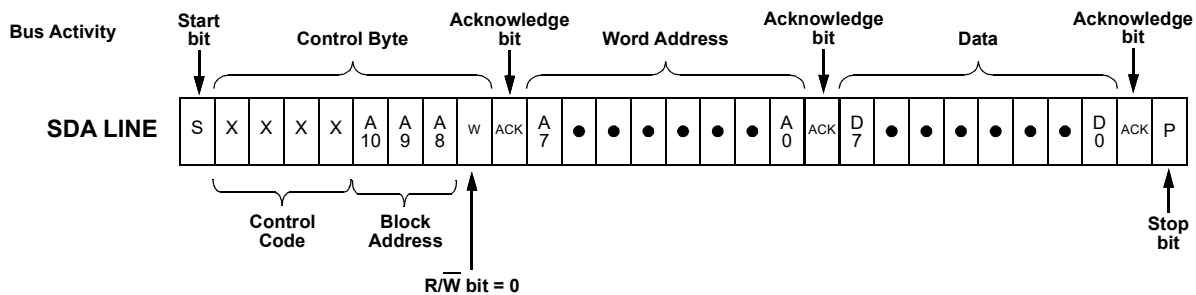

Figure 238: Byte Write Command, $R/\bar{W} = 0$

SLG47004

GreenPAK Programmable Mixed-Signal Matrix with In-System Programmability and Advanced Analog Features

18.4.2 Sequential Write Command

The write Control Byte, Word Address, and the first data byte are transmitted to the SLG47004 in the same way as in a Byte Write command. However, instead of generating a Stop condition, the Bus Master continues to transmit data bytes to the SLG47004. Each subsequent data byte will increment the internal address counter, and will be written into the next higher byte in the command addressing. As in the case of the Byte Write command, the internal write cycle will take place at the time that the SLG47004 generates the Acknowledge bit.

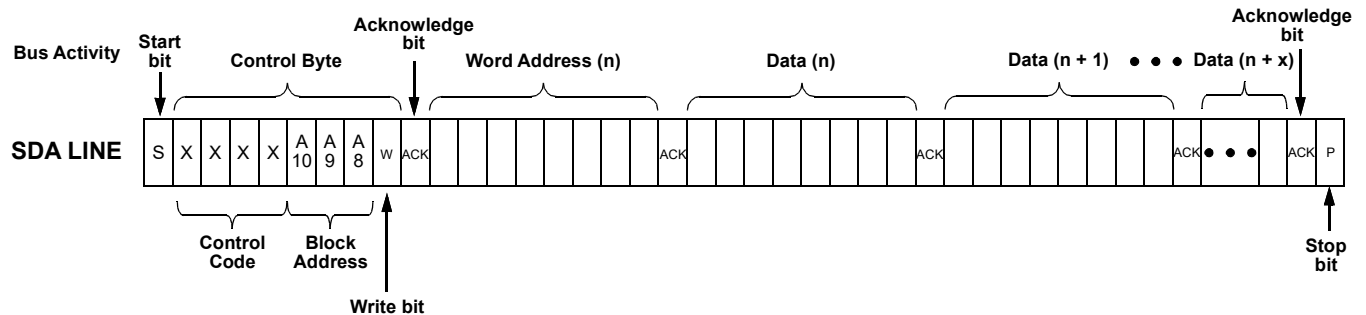

Figure 239: Sequential Write Command

18.4.3 Current Address Read Command

The Current Address Read Command reads from the current pointer address location. The address pointer is incremented at the first STOP bit following any write control byte. For example, if a Sequential Read command (which contains a write control byte) reads data up to address n, the address pointer would get incremented to n + 1 upon the STOP of that command. Subsequently, a Current Address Read that follows would start reading data at n + 1. The Current Address Read Command contains the Control Byte sent by the Master, with the R/W bit = "1". The SLG47004 will issue an Acknowledge bit, and then transmit eight data bits for the requested byte. The Master will not issue an Acknowledge bit, and follow immediately with a Stop condition

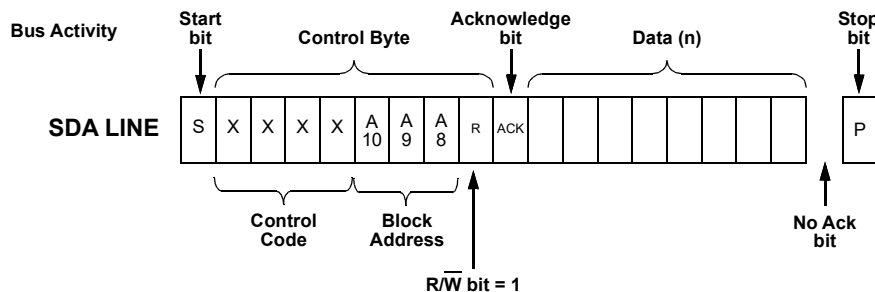

Figure 240: Current Address Read Command, $\overline{R/W} = 1$

18.4.4 Random Read Command

The Random Read command starts with a Control Byte (with R/W bit set to "0", indicating a write command) and Word Address to set the internal byte address, followed by a Start bit, and then the Control Byte for the read (exactly the same as the Byte Write command). The Start bit in the middle of the command will halt the decoding of a Write command, but will set the internal address counter in preparation for the second half of the command. After the Start bit, the Bus Master issues a second control byte with the R/W bit set to "1", after which the SLG47004 issues an Acknowledge bit followed by the requested eight data bits.

SLG47004

GreenPAK Programmable Mixed-Signal Matrix with In-System Programmability and Advanced Analog Features

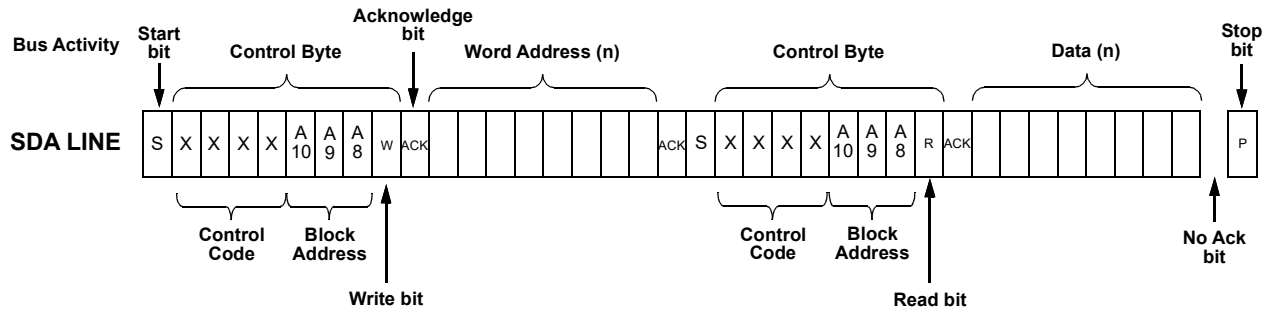

Figure 241: Random Read Command

18.4.5 Sequential Read Command

The Sequential Read command is initiated in the same way as a Random Read command, except that once the SLG47004 transmits the first data byte, the Bus Master issues an Acknowledge bit as opposed to a Stop condition in a random read. The Bus Master can continue reading sequential bytes of data, and will terminate the command with a Stop condition.

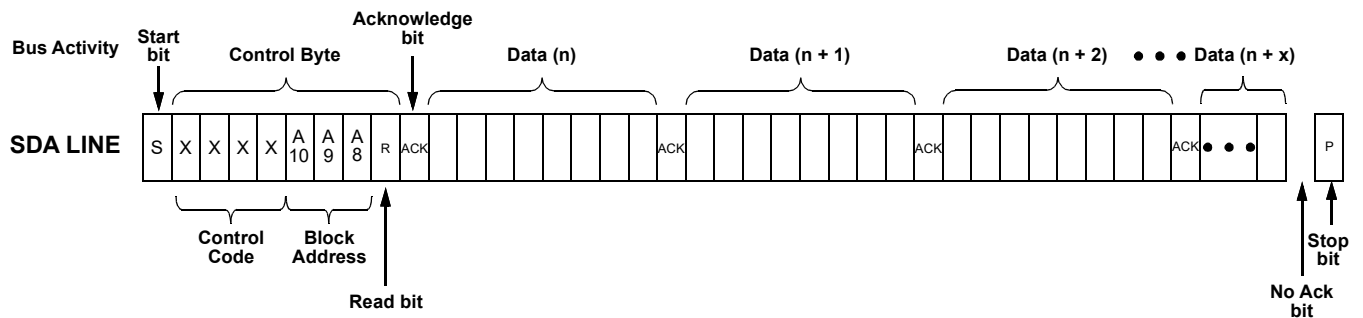

Figure 242: Sequential Read Command

18.4.6 I²C Serial Reset Command

If I²C serial communication is established with the device, it is possible to reset the device to initial power up conditions, including configuration of all macrocells and all connections provided by the Connection Matrix. This is implemented by setting register [984] I²C reset bit to “1”, which causes the device to re-enable the Power-On Reset (POR) sequence, including the reload of all register data from NVM. During the POR sequence, the outputs of the device will be in tri-state. After the reset has taken place, the contents of register [984] will be set to “0” automatically. The Figure 243 illustrates the sequence of events for this reset function.

SLG47004

GreenPAK Programmable Mixed-Signal Matrix with In-System Programmability and Advanced Analog Features

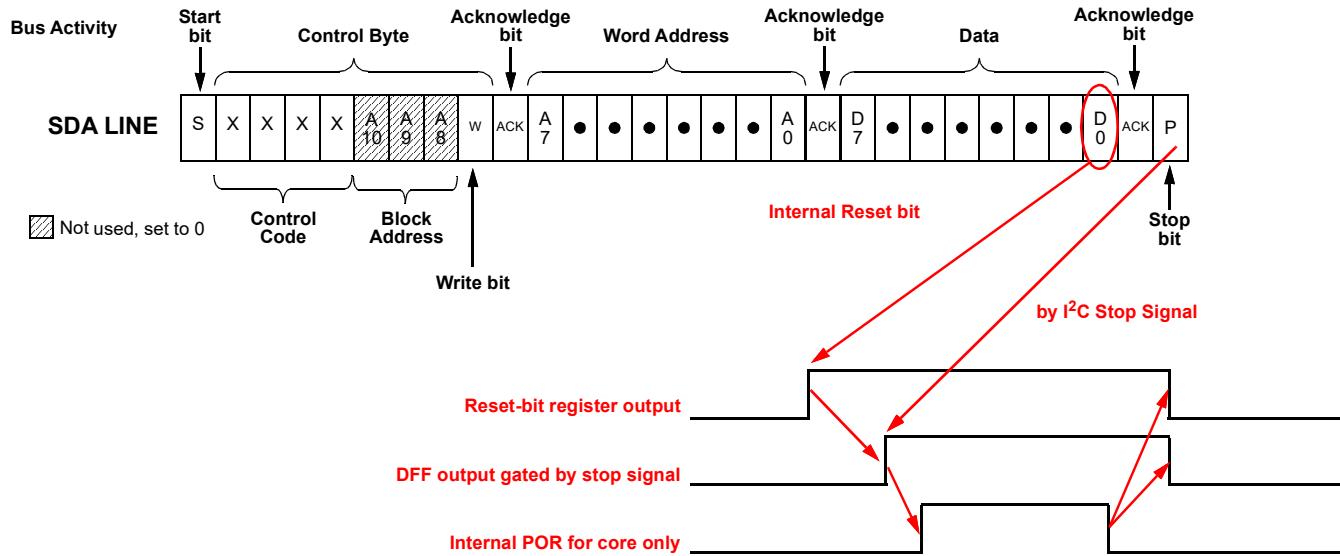

Figure 243: Reset Command Timing

18.5 CHIP CONFIGURATION DATA PROTECTION

The SLG47004 utilizes a scheme that allows a portion or the entire Register and NVM to be inhibited from being read or written/erased. There are two bytes that define the register and NVM access or change. The second byte NPR defines the chip NVM data configuration read and write protection. The first byte RPR defines the register read and write protection. If desired, the protection lock bit (PRL) can be set so that protection may no longer be modified, thereby making the current protection scheme permanent. The status of the RPR and NPR can be determined by following a Random Read sequence. Changing the state of the RPR and NPR is accomplished with a Byte Write sequence with the requirements outlined in this section.

Special care must be taken when NVM page 14 is rewritten (registers [1919:1792]). This page contains rheostats tolerance data that can be permanently lost during write/erase operation.

The RPR register is located on H'E0 address, while NPR is located on H'E1 address.

The RPR format is shown in Table 60, and the RPR bit functions are included in Table 61.

Table 60: RPR Format

	b7	b6	b5	b4	b3	b2	b1	b0
RPR				RH_PRB	RPRB3	RPRB2	RPRB1	RPRB0

* Becomes read only after PRL is high. The content is permanently locked for write and erase after PRL is high.

Table 61: RPR Bit Function Description

Bit	Name	Type	Description
4	RH_PRB	--	R/W* 0: Program signal from connection matrix is enabled 1: Program signal from connection matrix is disabled
3:2	RPRB3	2k Register Write Selection Bits	R/W* 00: 2k register data is unprotected for write; 01: 2k register data is partly protected for write; Please refer to the Table 64. 10: 2k register data is fully protected for write.
	RPRB2		

SLG47004

GreenPAK Programmable Mixed-Signal Matrix with In-System Programmability and Advanced Analog Features

Table 61: RPR Bit Function Description(Continued)

Bit	Name		Type	Description
1:0	RPRB1	2k Register Read Selection Bits	R/W*	00: 2k register data is unprotected for read; 01: 2k register data is partly protected for read; Please refer to the Table 64 . 10: 2k register data is fully protected for read.
	RPRB0		R/W*	

The NPR format is shown in [Table 62](#), and the NPR bit functions are included in [Table 63](#).

Table 62: NPR Format

	b7	b6	b5	b4	b3	b2	b1	b0
NPR							NPRB1	NPRB0

Table 63: NPR Bit Function Description

Bit	Name		Type	Description
1:0	NPRB1	2k NVM Configuration Selection Bits	R/W*	00: 2k NVM Configuration data is unprotected for read and write/erase; 01: 2k NVM Configuration data is fully protected for read; 10: 2k NVM Configuration data is fully protected for write/erase; 11: 2k NVM Configuration data is fully protected for read and write/erase.
	NPRB0		R/W*	

* Becomes read only after PRL is high. The content is permanently locked for write and erase after PRL is high.

The protection selection bits allow different levels of protection of the register and NVM Memory Array.

There is a dedicated bit RH_PRB, that enables/disables "Program" signal of PT block to change NVM rheostats resistance values. If RH_PRB [1796] = 0, "Program" signal is enabled. If RH_PRB [1796] = 1, "Program" signal is disabled. Note that RH_PRB bit has no effect on I²C access to NVM. To enable/disable I²C access to rheostat resistance value, stored in NVM, user must change NPRB0, NPRB1 bits.

The Protect Lock Bit (PRL) is used to permanently lock (for write and erase) the current state of the RPR and NPR, as well as EEPROM protection. A Logic 0 indicates that the protection byte can be modified, whereas a Logic 1 indicates the byte has been locked and can no longer be modified.

In this case it is impossible to erase the whole page E with protection bytes. The PRL is located at E4 address (register [1824]).

18.6 I²C SERIAL COMMAND REGISTER MAP

There are nine read/write protect modes for the design sequence from being corrupted or copied. See [Table 64](#) for details.

Table 64: Read/Write Register Protection Options

Configurations	Protection Modes Configuration									Test Mode	Register Address
	Unlock	Partly Lock Read	Partly Lock Write	Partly Lock Read/Write	Partly Lock Read & Lock Write	Lock Read & Partly Lock Write	Lock Read	Lock Write	Lock Read/Write		
RPR[1:0]	00	01	00	01	01	10	10	00	10		
RPR[3:2]	00	00	01	01	10	01	00	10	10		
I ² C Byte Write Bit Masking (section 18.7.2)	R/W	R/W	R/W	R/W	R	W	W	R	-	-	F6
I ² C Serial Reset Command (section 18.4.6)	R/W	R/W	R/W	R/W	R	W	W	R	-	-	7Bb'0

**GreenPAK Programmable Mixed-Signal Matrix
with In-System Programmability and Advanced Analog Features**
Table 64: Read/Write Register Protection Options(Continued)

Configurations	Protection Modes Configuration									Test Mode	Register Address
	Unlock	Partly Lock Read	Partly Lock Write	Partly Lock Read/Write	Partly Lock Read & Lock Write	Lock Read & Partly Lock Write	Lock Read	Lock Write	Lock Read/Write		
RPR[1:0]	00	01	00	01	01	10	10	00	10		
RPR[3:2]	00	00	01	01	10	01	00	10	10		
Outputs Latching During I ² C Write (section 18.7)	R/W	R/W	R/W	R/W	R	W	W	R	-	-	7Bb'1
Connection Matrix Virtual Inputs (section 6.3)	R/W	R/W	R/W	R/W	R	W	W	R	-	-	7C
RH0_CNT Data	R/W	R/W	R/W	R/W	R	W	W	R	-	R/W	C0,C1
RH1_CNT Data	R/W	R/W	R/W	R/W	R	W	W	R	-	R/W	D0,D1
Macrocells Output Values (Connection Matrix Inputs, section 6.3)	R	R	R	R	R	-	-	R	-	R	C4~CA
Counter Current Value	R	R	R	R	R	-	-	R	-	R	CB~CE
RH0_CNT Value	R	R	R	R	R	R	R	R	R	R	C2,C3
RH1_CNT Value	R	R	R	R	R	R	R	R	R	R	D2,D3
Protection Mode Selection (sections 18.6, 19.6)	R/W	R/W	R	R	R	R	R/W	R	R7	R	E4'b0
I ² C Slave Address	R/W	R/W	R	R	R	R	R/W	R	R	R	7Fb'3~7Fb'0
Pin slave address select	R/W	R/W					R/W				7Fb'7~7Fb'4
Service page lock	R	R	R	R	R	R	R	R	R	R	F3b'0
RH0 Tolerance Data	R	R	R	R	R	R	R	R	R	R	E6,E7
RH1 Tolerance Data	R	R	R	R	R	R	R	R	R	R	E8,E9
Protect Mode Config (RH_PRB,RPR,NPR,WPR)	R/W*	R/W*	R/W*	R/W*	R/W*	R/W*	R/W*	R/W*	R/W*	R/W*	E0, E1, E2
Page Erase byte	W**	W**	W**	W**	W**	W**	W**	W**	W**	W**	E3
Macrocells Inputs Configuration (Connection Matrix Outputs) (section 6.2)	R/W	W	R	-	-	-	W	R	-	-	00~4A (4B rev)
Configuration Bits for All Macrocells (IOs, ACMPs, Combination Function Macrocells, and others)	R/W	W	R	-	-	-	W	R	-	-	

R/W	Allow Read and Write Data
W	Allow Write Data Only
W**	Pages that can be erased are defined by NVM write protection

SLG47004

GreenPAK Programmable Mixed-Signal Matrix with In-System Programmability and Advanced Analog Features

R	Allow Read Data Only
-	The Data is protected for Read and Write

Note 1 R/W becomes read only if protection mode selection (lock bit) is set to 1.

Note 2 R/W Readable/writable depend on the "Trim mode enable" bit. If "Trim mode enable" bit value = 1, then trim bits are enable.

It is possible to read some data from macrocells, such as counter current value, connection matrix, and connection matrix virtual inputs. The I²C write will not have any impact on data in case data comes from macrocell output, except Connection Matrix Virtual Inputs. The silicon identification service bits allow identifying silicon family, its revision, and others.

R/W* - Becomes read only after PRL is high. See Section 21 for detailed information on all registers.

SLG47004

GreenPAK Programmable Mixed-Signal Matrix with In-System Programmability and Advanced Analog Features

18.7 I²C ADDITIONAL OPTIONS

When Output latching during I²C write to the register configuration data (block address A10, A9, A8 = 000), registers [985] = 1 allows all PINs output value to be latched while register content is changing. It will protect the output change due to configuration process during I²C write in case multiple register bytes are changed. Inputs and internal macrocells retain their status during I²C write.

See Section 21 for detailed information on all registers.

18.7.1 Reading Counter Data via I²C

The current count value in three counters in the device can be read via I²C. The counters that have this additional functionality are 16-bit CNT0, and 8-bit counters CNT2 and CNT4.

18.7.2 I²C Byte Write Bit Masking

The I²C macrocell inside SLG47004 supports masking of individual bits within a byte that is written to the RAM memory space. This function is supported across the entire RAM memory space. To implement this function, the user performs a Byte Write Command (see Section 18.4.1 for details) on the I²C Byte Write Mask Register (address 0F6H) with the desired bit mask pattern. This sets a bit mask pattern for the target memory location that will take effect on the next Byte Write Command to this register byte. Any bit in the mask that is set to “1” in the I²C Byte Write Mask Register will mask the effect of changing that particular bit in the target register, during the next Byte Write Command. The contents of the I²C Byte Write Mask Register are reset (set to 00h) after valid Byte Write Command. If the next command received by the device is not a Byte Write Command, the effect of the bit masking function will be aborted, and the I²C Byte Write Mask Register will be reset with no effect. Figure 244 shows an example of this function.

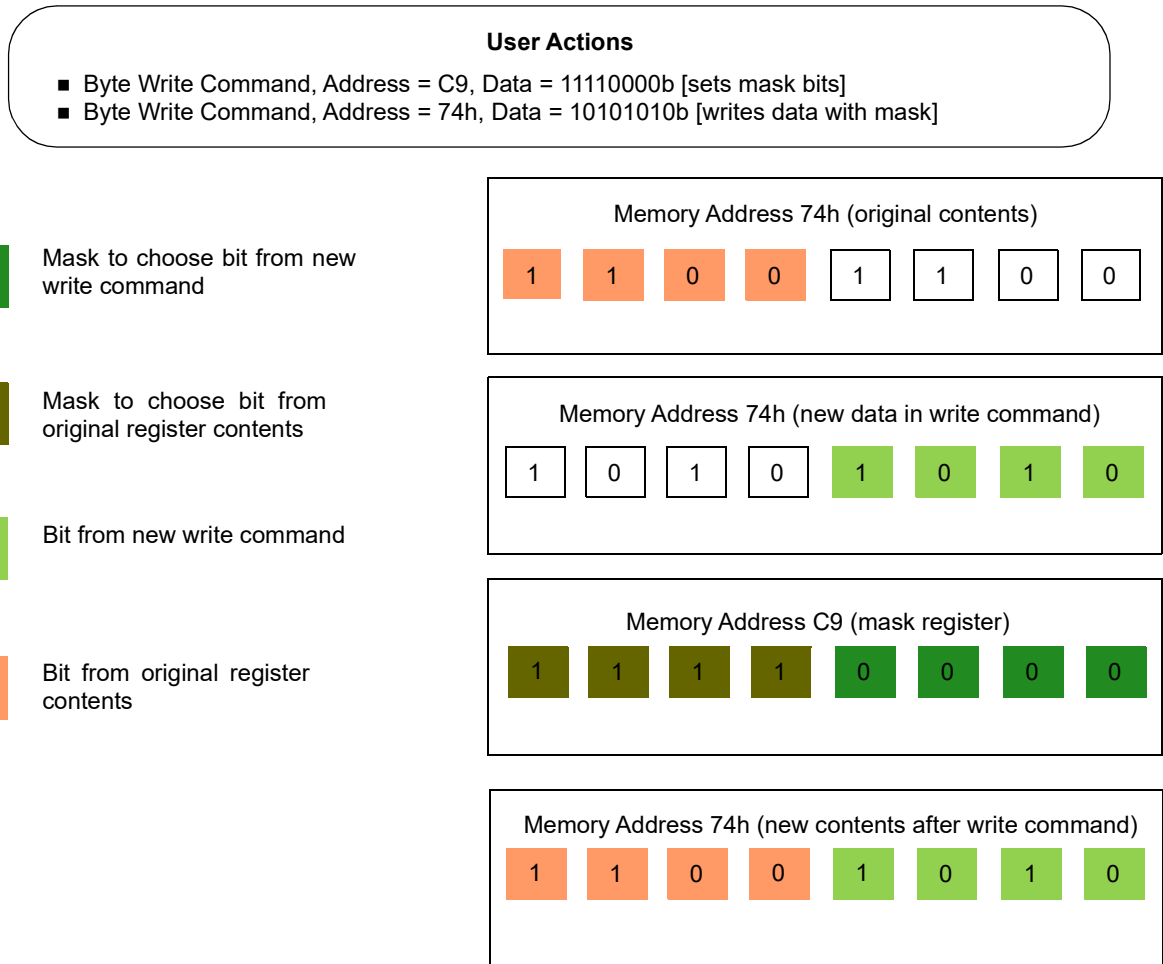

Figure 244: Example of I²C Byte Write Bit Masking

19 Non-Volatile Memory

The SLG47004 provides 2,048 bits of Serial Electrically Erasable Configuration Register memory that is used for device configuration, and 2,048 bits Programmable Read-Only Memory (emulated EEPROM). Each of these memory spaces is internally organized as 16 pages of 16 bytes. The device features a Software Write Protection feature with five different programmable levels of protection for the emulated EEPROM array. The protection settings of the device can be made permanent if desired. The emulated EEPROM memory operates with a supply voltage ranging from 2.4 V to 5.5 V for Read and 2.5 V to 5.5 V for Write.

The emulated EEPROM inside the SLG47004 operates as a slave device and utilizes a simple I²C compatible 2-wire digital serial interface to communicate with a host controller commonly referred to as the bus Master. The Master initiates and controls all read and write operations to the Slave devices on the serial bus, and both the Master and the Slave devices can transmit and receive data on the bus.

Key features:

- Low-voltage Operation
 - for Read: VCC = 2.4 V to 5.5 V
 - for Write: VCC = 2.5 V to 5.5 V
- I²C-Compatible (2-Wire) Serial Interface
 - 100 kHz Standard Mode
 - 400 kHz Fast Mode (FM)
- Software Write Protection of the EEPROM Emulation Array
 - Five configuration options
 - Protection settings can be made permanent
- Low Current Consumption
 - Read Current 0.5 mA max
 - Page Write Current 3.0 mA max
 - Chip Erase Current 3.0 mA max
 - Standby Current (1.0 μA max)
- 16-byte Page Write Mode
- Self-timed Write/Erase Cycle (20 ms max)
- Reliability
 - Endurance: 1,000 write cycles
 - Data retention: 10 years at 125 °C

19.1 SERIAL NVM WRITE OPERATIONS

Write access to the NVM is possible by setting A3, A2, A1, A0 to “0000”, which allows serial write data for a single page only. Upon receipt of the proper Control Byte and Word Address bytes, the SLG47004 will send an ACK. The device will then be ready to receive page data, which is 16 sequential writes of 8-bit data words. The SLG47004 will respond with an ACK after each data word is received. The addressing device, such as a bus Master, must then terminate the write operation with a Stop condition after all page data is written. At that time the device will enter an internally self-timed write cycle, which will be completed within t_{WR} (20 ms). While the data is being written into the NVM Memory Array, all inputs, outputs, internal logic, and I²C access to the Register data will be operational/valid. Please refer to [Figure 246](#) for the SLG47004 Memory Map.

Note: The 16 programmed bytes should be in the same page. Any I²C command that does not meet specific requirements will be ignored and NVM will remain unprogrammed.

Note: Special care must be taken when NVM page 14 is rewritten (registers [1919:1792]). This page contains rheostats tolerance data that can be permanently lost during write/erase operation.

SLG47004 will ignore the Serial NVM Write command in case the self-programming procedure for programming rheostat value into the NVM is in progress. The SLG47004 will respond with NACK in this case. Please refer to the Acknowledge Polling section for more details.

SLG47004

GreenPAK Programmable Mixed-Signal Matrix with In-System Programmability and Advanced Analog Features

Data “1” cannot be re-programmed as data “0” without erasure. Each byte can only be programmed one time without erasure.

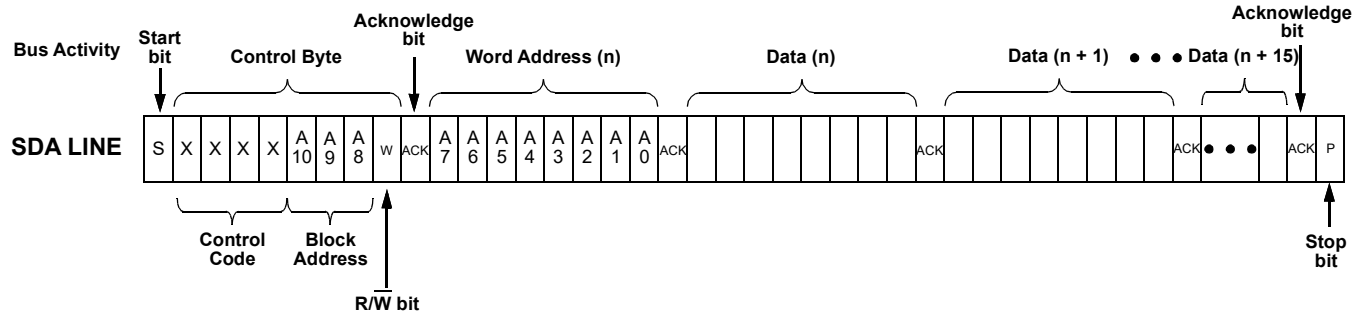

Figure 245: Page Write Command

A10 will be ignored during communication to SLG47004.

A9 = 1 will enable access to the NVM.

A9 = 1 and A8 = 0 corresponds to the 2K bits chip configuration NVM data.

A9 = 1 and A8 = 1 corresponds to the 2K bits of emulated EEPROM data.

A3, A2, A1, and A0 should be 0000 for the page write operation.

In a single page, if the data written to any byte is 00H, the contents of the matching byte in NVM memory will not be altered.

SLG47004

GreenPAK Programmable Mixed-Signal Matrix with In-System Programmability and Advanced Analog Features

I ² C Block Address		Memory Space	
A10 = 0	A9 = 0	A8 = 0	2 kbits Register Data Configuration
A10 = 0	A9 = 0	A8 = 1	Not Used
A10 = 0	A9 = 1	A8 = 0	2 kbits NVM Data Configuration
A10 = 0	A9 = 1	A8 = 1	2 kbits EEPROM
A10 = 1	A9 = X	A8 = X	Not Used

Lowest I²C Address = 000h

Highest I²C Address = 7FFh

Figure 246: I²C Block Addressing

19.2 SERIAL NVM READ OPERATIONS

There are three read operations:

- Current Address Read
- Random Address Read
- Sequential Read

Please refer to the Section 18 for more details.

19.3 SERIAL NVM ERASE OPERATIONS

The erase scheme allows a portion or the entire emulated EEPROM including the 2K bits NVM chip configuration to be erased by modifying the contents of the Erase Registers (ERSE <2:0>). Changing the state of the ERSE is accomplished with a Byte Write sequence with the requirements outlined in this section.

The ERSE registers are located on byte E3h.

The ERSE format is shown in Table 65, and the ERSE bit functions are included in Table 66.

Table 65: Erase Register Bit Format

	b7	b6	b5	b4	b3	b2	b1	b0
Page Erase Register	ERSE2	ERSE1	ERSE0	ERSEB4	ERSEB3	ERSEB2	ERSEB1	ERSEB0

Table 66: Erase Register Bit Function Description

Bit	Name	Type	Description
7	ERSE2	W	000: erase disable 110: cause the NVM erase
6	ERSE1		
5	ERSE0		
4	ERSEB4	W	Define the page address, which will be erased: ERSB4 = 0 corresponds to the Upper 2K NVM used for chip configuration; ERSB4 = 1 corresponds to the 2-k emulated EEPROM
3	ERSEB3		
2	ERSEB2		
1	ERSEB1		
0	ERSEB0		

Upon receipt of the proper Device Address and Erase Registers Address, the SLG47004 will send an ACK. The device will then be ready to receive Erase Registers data. The SLG47004 will respond with an ACK after Erase Registers data word is received. The addressing device, such as a bus Master, must then terminate the write operation with a Stop condition. At that time the device will enter an internally self-timed erase cycle, which will be completed within t_{ER} ms. While the data is being written into the Memory Array, all inputs, outputs, internal logic, and I²C access to the Register data will be operational/valid.

After the erase has taken place, the contents of ERSE bits will be set to “0” automatically. The internal erase cycle will be triggered at the time the Stop Bit in the I²C command is received.

19.4 ACKNOWLEDGE POLLING

An Acknowledge Polling routine can be implemented to optimize time sensitive applications that would prefer not to wait the fixed maximum write cycle time (t_{WR}) or erase maximum cycle time (t_{ER}). This method allows the application to know immediately when the Serial EEPROM emulation write/erase cycle has completed, so a subsequent operation can be started. Once the internally self-timed write/erase cycle has started, an Acknowledge Polling routine can be initiated. This involves repeatedly sending a Start condition followed by a valid Device Address byte (NVM block address) with the R/W bit set at Logic 0. The device will not respond with an ACK while the write cycle is ongoing. Once the internal write/erase cycle has completed, emulated EEPROM will respond with an ACK, allowing a new read, erase, or write operation to be immediately initiated.

The same behavior will happen during the self-programming procedure when the rheostat value is written into the NVM.

The length of the self-timed write cycle (t_{WR}) and self-timed erase cycle (t_{ER}) is defined as the amount of time from the Stop condition that begins the internal write operation to the Start condition of the first Device Address byte that includes NVM address (A9 = 1; A8 = X) sent to the SLG47004, that it subsequently responds to with an ACK.

19.5 LOW POWER STANDBY MODE

Emulated EEPROM inside the SLG47004 has a low power standby mode which is enabled when any one of the following occurs:

- A valid power-up sequence is performed
- A Stop condition is received by the devices unless it initiates an internal write/erase cycle
- At the completion of an internal write/erase cycle
- An unsuccessful match of the device type identifier or hardware address in the Device Address byte occurs

19.6 EMULATED EEPROM WRITE PROTECTION

The SLG47004 utilizes a software scheme that allows a portion or the entire emulated EEPROM to be inhibited from being written or erased by modifying the contents of the Write Protection Register (WPR). If desired, the WPR can be set so that it may no longer be modified/erased, thereby making the current protection scheme permanent. The status of the WPR can be determined by following a Random Read sequence. Changing the state of the WPR is accomplished with a Byte Write sequence with the requirements outlined in this section.

SLG47004

GreenPAK Programmable Mixed-Signal Matrix with In-System Programmability and Advanced Analog Features

The WPR register is located at E2 Address.

The WPR format is shown in [Table 67](#), and the WPR bit functions are included in [Table 68](#).

Table 67: Write/Erase Protect Register Format

	b7	b6	b5	b4	b3	b2	b1	b0
WPR						WPRE	WPB1	WPB0

Table 68: Write/Erase Protect Register Bit Function Description

Bit	Name	Type	Description
2	WPRE	R/W	Write Protect Register Enable 0: No Software Write Protection enabled (default) 1: Write Protection is set by the state of WPB [1:0] bits
1:0	WPB1	R/W	Write Protect Block Bits 00: Upper quarter of emulated EEPROM is write protected (default) 01: Upper half of emulated EEPROM is write protected 10: Upper 3/4 of emulated EEPROM is write protected. 11: Entire emulated EEPROM is write protected.
	WPB0	R/W	

Write Protect Enable (WPRE): The Write Protect Enable Bit is used to enable or disable the device Software Write/Erase Protect. A Logic 0 in this position will disable Software Write/Erase Protection, and a Logic 1 will enable this function.

Write Protect Block Bits (WPB1:WPB0): The Write Protect Block bits allow four levels of protection of the Memory Array, provided that the WPRE bit is a Logic 1. If the WPRE bit is a Logic 0, the state of the WPB1:0 bits have no impact on device protection.

Protect Lock Bit (PRL): The Protect Lock Bit is used to permanently lock the current state of the WPR, as well as RPR and NPR (see [Section 18.5](#)). A Logic 0 indicates that the WPR, RPR, and NPR can be modified, whereas a Logic 1 indicates the WPR, RPR, and NPR has been locked and can no longer be modified. The PRL register bit is located at register [1824] address.

20 Analog Temperature Sensor

The SLG47004 has an Analog Temperature sensor (TS) with an output voltage linearly-proportional to the Centigrade temperature. The TS cell shares buffer with Vref 0, so it is impossible to use both cells simultaneously, its output can be connected directly to the IO0 or IO1 or the ACPM1_L positive input. Using buffer causes low-output impedance, linear output and makes interfacing to readout or control circuitry especially easy. Vref0 and Vref1 share output buffers with Temperature sensor. Note, that user can use any of output buffers, but Temperature sensor is calibrated for Vref1 output buffer. The TS is rated to operate over a -40 °C to 85 °C temperature range. The error in the whole temperature range does not exceed ±1.76 %. For more details refer to Section [3.12](#).

$$V_{TS1} = -2.4 \times T + 900.2$$

$$V_{TS2} = -2.8 \times T + 1082.7$$

where:

V_{TS1} (mV) - TS Output Voltage, range 1

V_{TS2} (mV) - TS Output Voltage, range 2

T (°C) - Temperature

SLG47004

GreenPAK Programmable Mixed-Signal Matrix
with In-System Programmability and Advanced Analog Features

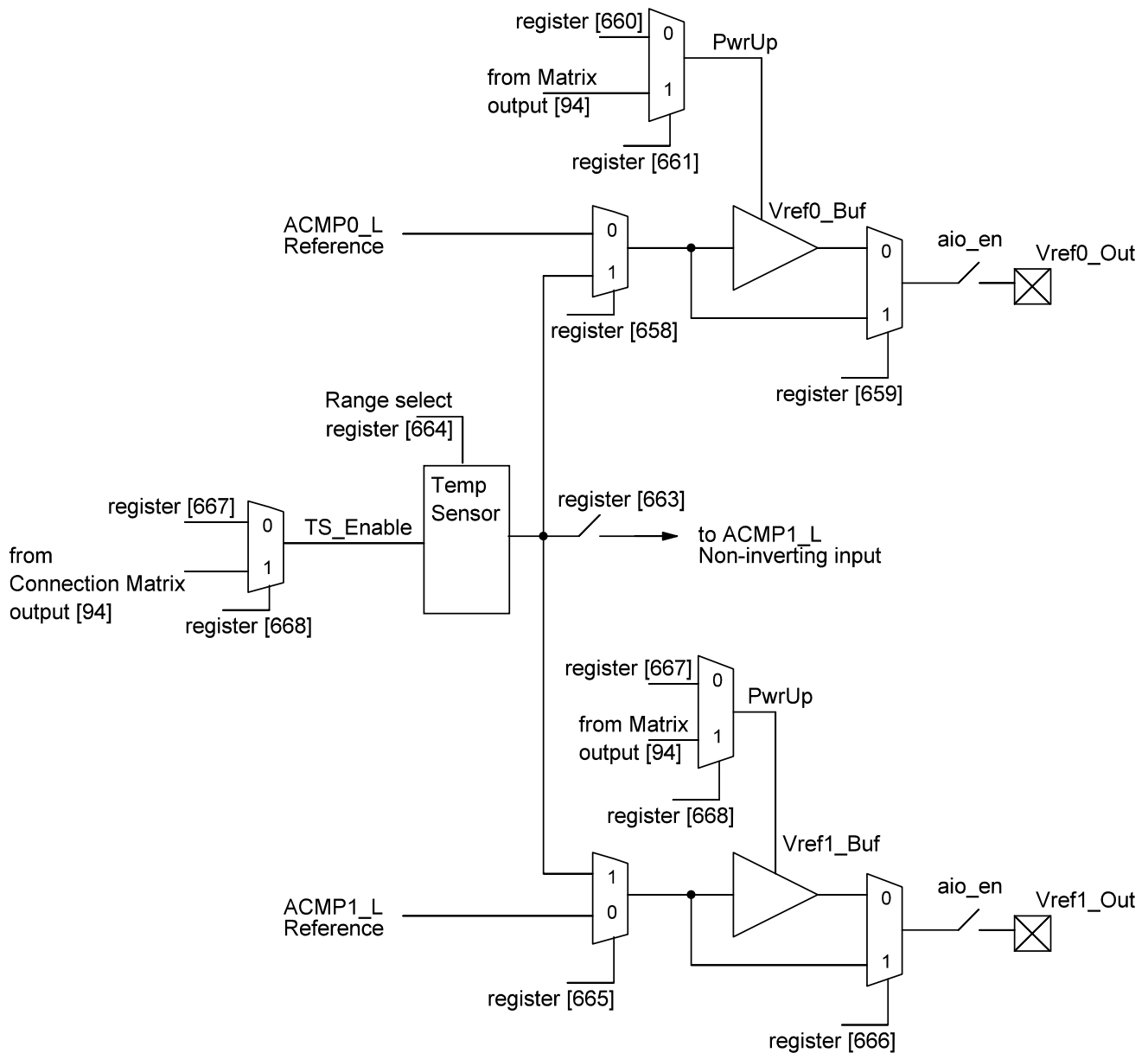

Figure 247: Analog Temperature Sensor Structure Diagram

SLG47004

GreenPAK Programmable Mixed-Signal Matrix
with In-System Programmability and Advanced Analog Features

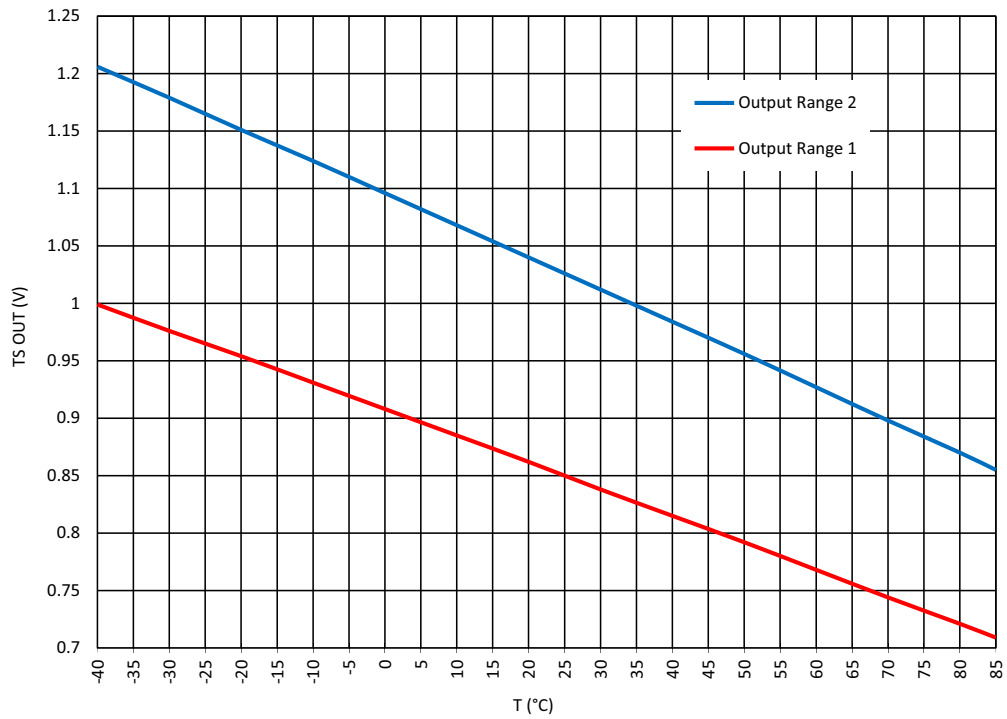

Figure 248: TS Output vs. Temperature, V_{DD} = 3.3 V

SLG47004

GreenPAK Programmable Mixed-Signal Matrix with In-System Programmability and Advanced Analog Features

21 Register Definitions

21.1 REGISTER MAP

Table 69: Register Map

Address		Signal Function	Register Bit Definition
Byte	Register Bit		
Matrix Output			
0	0	2-bit LUT0 & DFF0	OUT0: IN0 of 2-bit LUT0 or Clock Input of DFF0
	1		
	2		
	3		
	4		
	5		
	6		
1	7	2-bit LUT1 & DFF1	OUT1: IN1 of 2-bit LUT0 or Data Input of DFF0
	8		
	9		
	10		
	11		
	12		
	13		
2	14	2-bit LUT2 & DFF2	OUT2: IN0 of 2-bit LUT1 or Clock Input of DFF1
	15		
	16		
	17		
	18		
	19		
	20		
3	21	2-bit LUT3 & PGen	OUT3: IN1 of 2-bit LUT1 or Data Input of DFF1
	22		
	23		
	24		
	25		
	26		
	27		
4	28	2-bit LUT0 & DFF0	OUT4: IN0 of 2-bit LUT2 or Clock Input of DFF2
	29		
	30		
	31		
	32		
	33		
	34		
4	35	2-bit LUT1 & DFF1	OUT5: IN1 of 2-bit LUT2 or Data Input of DFF2
	36		
	37		
	38		
	39		
4	37	2-bit LUT3 & PGen	OUT6: IN0 of 2-bit LUT3 or Clock Input of PGen
	38		
	39		
	39		
	39		

SLG47004

GreenPAK Programmable Mixed-Signal Matrix with In-System Programmability and Advanced Analog Features

Table 69: Register Map (Continued)

Address		Signal Function	Register Bit Definition
Byte	Register Bit		
5	40	2-bit LUT3 & PGen	OUT6: IN0 of 2-bit LUT3 or Clock Input of PGen
	41		
	42		
	43		OUT7: IN1 of 2-bit LUT3 or nRST of PGen
	44		
	45		
	46		
47			
6	48	3-bit LUT0 & DFF3	OUT8: IN0 of 3-bit LUT0 or CLK Input of DFF3
	49		
	50		
	51		OUT9: IN1 of 3-bit LUT0 or Data Input of DFF3
	52		
	53		
	54		
55			
7	56	3-bit LUT1 & DFF4	OUT10: IN2 of 3-bit LUT0 or nRST (nSET) of DFF3
	57		
	58		
	59		OUT11: IN0 of 3-bit LUT1 or CLK Input of DFF4
	60		
	61		
	62		
63			
8	64	3-bit LUT1 & DFF4	OUT12: IN1 of 3-bit LUT1 or Data Input of DFF4
	65		
	66		
	67		OUT13: IN2 of 3-bit LUT1 or nRST (nSET) of DFF4
	68		
	69		
	70		
71			
9	72	3-bit LUT1 & DFF4	OUT12: IN1 of 3-bit LUT1 or Data Input of DFF4
	73		
	74		
	75		OUT13: IN2 of 3-bit LUT1 or nRST (nSET) of DFF4
	76		
	77		
	78		
79			
A	80	3-bit LUT1 & DFF4	OUT13: IN2 of 3-bit LUT1 or nRST (nSET) of DFF4
	81		
	82		
	83		

SLG47004

GreenPAK Programmable Mixed-Signal Matrix with In-System Programmability and Advanced Analog Features

Table 69: Register Map (Continued)

Address		Signal Function	Register Bit Definition	
Byte	Register Bit			
A	84	3-bit LUT2 & DFF5	OUT14: IN0 of 3-bit LUT2 or CLK Input of DFF5	
	85			
	86			
	87			
B	88		3-bit LUT2 & DFF5	OUT15: IN1 of 3-bit LUT2 or Data Input of DFF5
	89			
	90			
	91			
	92			
	93			
	94			
C	95		3-bit LUT2 & DFF5	OUT16: IN2 of 3-bit LUT2 or nRST (nSET) of DFF5
	96			
	97			
	98			
	99			
	100			
D	101	3-bit LUT3 & DFF6	OUT17: IN0 of 3-bit LUT3 or CLK Input of DFF6	
	102			
	103			
	104			
	105			
	106			
	107			
E	108	3-bit LUT3 & DFF6	OUT18: IN1 of 3-bit LUT3 or Data Input of DFF6	
	109			
	110			
	111			
	112			
F	113	3-bit LUT4 & DFF7	OUT19: IN2 of 3-bit LUT3 or nRST (nSET) of DFF6	
	114			
	115			
	116			
	117			
	118			
	119			
F	120	3-bit LUT4 & DFF7	OUT20: IN0 of 3-bit LUT4 or CLK Input of DFF7	
	121			
	122			
	123			
	124		OUT21: IN1 of 3-bit LUT4 or Data Input of DFF7	
	125			
	126			
	127			

SLG47004

GreenPAK Programmable Mixed-Signal Matrix with In-System Programmability and Advanced Analog Features

Table 69: Register Map (Continued)

Address		Signal Function	Register Bit Definition
Byte	Register Bit		
10	128	3-bit LUT4 & DFF7	OUT21: IN1 of 3-bit LUT4 or Data Input of DFF7
	129		
	130		
	131		
	132		
	133		
	134		OUT22: IN2 of 3-bit LUT4 or nRST (nSET) of DFF7
135			
11	136	3-bit LUT5 & DFF8	OUT23: IN0 of 3-bit LUT5 or CLK Input of DFF8
	137		
	138		
	139		
	140		
	141		
	142		OUT24: IN1 of 3-bit LUT5 or Data Input of DFF8
143			
12	144	3-bit LUT6 & DFF9	OUT25: IN2 of 3-bit LUT5 or nRST (nSET) of DFF8
	145		
	146		
	147		
	148		
	149		
	150		OUT26: IN0 of 3-bit LUT6 or CLK Input of DFF9
151			
13	152	3-bit LUT6 & DFF9	OUT27: IN1 of 3-bit LUT6 or Data Input of DFF9
	153		
	154		
	155		
	156		
	157		
	158		OUT28: IN2 of 3-bit LUT6 or nRST (nSET) of DFF9
159			
14	160	3-bit LUT6 & DFF9	OUT27: IN1 of 3-bit LUT6 or Data Input of DFF9
	161		
	162		
	163		
	164		
	165		
	166		
15	167	3-bit LUT6 & DFF9	OUT28: IN2 of 3-bit LUT6 or nRST (nSET) of DFF9
	168		
	169		
	170		
	171		
	172		
	173		

SLG47004

GreenPAK Programmable Mixed-Signal Matrix with In-System Programmability and Advanced Analog Features

Table 69: Register Map (Continued)

Address		Signal Function	Register Bit Definition	
Byte	Register Bit			
15	174	Multi_function1	OUT29: IN0 of 3-bit LUT7 or CLK Input of DFF11 Delay1 Input (or Counter1 nRST Input)	
	175			
16	176			
	177			
	178			
	179			
	180			
	181			
	182			
17	183			OUT30: IN1 of 3-bit LUT7 or nRST (nSET) of DFF11 Delay1 Input (or Counter1 nRST Input)
	184			
	185			
	186			
	187			
	188	OUT31: IN2 of 3-bit LUT7 or Data of DFF11 Delay1 Input (or Counter1 nRST Input)		
	189			
18	190			
	191			
	192	OUT32: IN0 of 3-bit LUT8 or CLK Input of DFF12 Delay2 Input (or Counter2 nRST Input)		
	193			
	194			
	195			
	196			
197				
198				
19	199	Multi_function2	OUT33: IN1 of 3-bit LUT8 or nRST (nSET) of DFF12 Delay2 Input (or Counter2 nRST Input)	
	200			
	201			
	202			
	203			
	204			
	205			
1A	206	Multi_function3	OUT34: IN2 of 3-bit LUT8 or Data of DFF12 Delay2 Input (or Counter2 nRST Input)	
	207			
	208			
	209			
	210			
	211			
	212			OUT35: IN0 of 3-bit LUT9 or CLK Input of DFF13 Delay3 Input (or Counter3 nRST Input)
213				
214				
215				

SLG47004

GreenPAK Programmable Mixed-Signal Matrix with In-System Programmability and Advanced Analog Features

Table 69: Register Map (Continued)

Address		Signal Function	Register Bit Definition
Byte	Register Bit		
1B	216	Multi_function3	OUT36: IN1 of 3-bit LUT9 or nRST (nSET) of DFF13 Delay3 Input (or Counter3 nRST Input)
	217		
	218		
	219		
	220		
	221		
	222		
1C	223	Multi_function4	OUT37: IN2 of 3-bit LUT9 or Data of DFF13 Delay3 Input (or Counter3 nRST Input)
	224		
	225		
	226		
	227		
	228		
	229		
1D	230	Multi_function5	OUT38: IN0 of 3-bit LUT10 or CLK Input of DFF14 Delay4 Input (or Counter4 nRST Input)
	231		
	232		
	233		
	234		
	235		
	236		
1E	237	Multi_function6	OUT39: IN1 of 3-bit LUT10 or nRST (nSET) of DFF14 Delay4 Input (or Counter4 nRST Input)
	238		
	239		
	240		
	241		
	242		
	243		
1F	244	Multi_function7	OUT40: IN2 of 3-bit LUT10 or Data of DFF14 Delay4 Input (or Counter4 nRST Input)
	245		
	246		
	247		
	248		
	249		
	250		
20	251	Multi_function8	OUT41: IN0 of 3-bit LUT11 or CLK Input of DFF15 Delay5 Input (or Counter5 nRST Input)
	252		
	253		
	254		
	255		
	256		
	257		
20	258	Multi_function9	OUT42: IN1 of 3-bit LUT11 or nRST (nSET) of DFF15 Delay5 Input (or Counter5 nRST Input)
	259		
	260		
	261		
	262		
	263		
	263		
20	264	Multi_function10	OUT43: IN2 of 3-bit LUT11 or Data of DFF15 Delay5 Input (or Counter5 nRST Input)
	265		
	266		
	267		
	268		
	269		
	270		

SLG47004

GreenPAK Programmable Mixed-Signal Matrix with In-System Programmability and Advanced Analog Features

Table 69: Register Map (Continued)

Address		Signal Function	Register Bit Definition
Byte	Register Bit		
21	264	Multi_function6	OUT44: IN0 of 3-bit LUT12 or CLK Input of DFF16 Delay6 Input (or Counter6 nRST Input)
	265		
	266		
	267		
	268		
	269		
	270		
22	271	Multi_function6	OUT45: IN1 of 3-bit LUT12 or nRST (nSET) of DFF16 Delay6 Input (or Counter6 nRST Input)
	272		
	273		
	274		
	275		
	276		
	277		
23	278	Multi_function6	OUT46: IN2 of 3-bit LUT12 or Data of DFF16 Delay6 Input (or Counter6 nRST Input)
	279		
	280		
	281		
	282		
	283		
	284		
24	285	3-bit LUT13 & Pipe Delay (RIPP CNT)	OUT47: IN0 of 3-bit LUT13 or Input of Pipe Delay or UP signal of RIPP CNT
	286		
	287		
	288		
	289		
	290		
	291		
25	292	3-bit LUT13 & Pipe Delay (RIPP CNT)	OUT48: IN1 of 3-bit LUT13 or nRST of Pipe Delay or nSET of RIPP CNT
	293		
	294		
	295		
	296		
	297		
	298		
26	299	4-bit LUT_DFF10	OUT49: IN2 of 3-bit LUT13 or Clock of Pipe Delay_RIPP CNT
	300		
	301		
	302		
	303		
	304		
	305		
26	306	4-bit LUT_DFF10	OUT50: IN0 of 4-bit LUT0 or CLK Input of DFF10
	307		
	308		
	309		
	310		
	311		
	311		
26	311	4-bit LUT_DFF10	OUT51: IN1 of 4-bit LUT0 or Data of DFF10
	311		
	311		
	311		
	311		
	311		
	311		

SLG47004

GreenPAK Programmable Mixed-Signal Matrix with In-System Programmability and Advanced Analog Features

Table 69: Register Map (Continued)

Address		Signal Function	Register Bit Definition
Byte	Register Bit		
27	312	4-bit LUT_DFF10	OUT52: IN2 of 4-bit LUT0 or nRST (nSET) of DFF10
	313		
	314		
	315		
	316		
	317		
	318		
28	319	Multi_function0	OUT53: IN3 of 3-bit LUT0
	320		
	321		
	322		
	323		
	324		
	325		
29	326	Multi_function0	OUT54: IN0 of 4-bit LUT1 or CLK Input of DFF17 Delay0 Input (or Counter0 nRST Input)
	327		
	328		
	329		
	330		
	331		
	332		
2A	333	Multi_function0	OUT55: IN1 of 4-bit LUT1 or nRST of DFF17 Delay0 Input (or Counter0 nRST Input) Delay/Counter0 External CLK source
	334		
	335		
	336		
	337		
	338		
	339		
2B	340	Programmable delay	OUT56: IN2 of 4-bit LUT1 or nSET of DFF17 Delay0 Input (or Counter0 nRST Input) Delay/Counter0 External CLK source KEEP Input of FSM0
	341		
	342		
	343		
	344		
	345		
	346		
2C	347	Filter/Edge detector	OUT57: IN3 of 4-bit LUT1 or Data of DFF17 Delay0 Input (or Counter0 nRST Input) UP Input of FSM
	348		
	349		
	350		
	351		
	352		
	353		
2C	354	Filter/Edge detector	OUT58: Programmable delay/edge detect input
	355		
	356		
	357		
	358		
	359		
2C	354	Filter/Edge detector	OUT59: Filter/Edge detect input
	355		
	356		
	357		
	358		
	359		

SLG47004

GreenPAK Programmable Mixed-Signal Matrix with In-System Programmability and Advanced Analog Features

Table 69: Register Map (Continued)

Address		Signal Function	Register Bit Definition
Byte	Register Bit		
2D	360	IO0	OUT60: IO0 DOUT
	361		
	362		
	363		
	364		
	365		
	366		
2E	367	IO1	OUT61: IO0 DOUT OE
	368		
	369		
	370		
	371		
	372		
	373		
2F	374	IO2	OUT62: IO1 DOUT
	375		
	376		
	377		
	378		
	379		
	380		
30	381	IO3	OUT63: IO1 DOUT OE
	382		
	383		
	384		
	385		
	386		
	387		
31	388	IO0	OUT64: IO2 DOUT
	389		
	390		
	391		
	392		
	393		
	394		
32	395	IO1	OUT65: IO2 DOUT OE
	396		
	397		
	398		
	399		
	400		
	401		
32	402	IO2	OUT66: IO3 DOUT
	403		
	404		
	405		
	406		
	407		
	407		
32	408	IO3	OUT67: IO3 DOUT OE
	409		
	410		
	411		
	412		
	413		
	414		

SLG47004

GreenPAK Programmable Mixed-Signal Matrix with In-System Programmability and Advanced Analog Features

Table 69: Register Map (Continued)

Address		Signal Function	Register Bit Definition
Byte	Register Bit		
33	408	IO4	OUT68: IO4 DOUT
	409		
	410		
	411		
	412		
	413		
	414		
34	415	IO5	OUT69: IO4 DOUT OE
	416		
	417		
	418		
	419		
	420		
	421		
35	422	IO6	OUT70: IO5 DOUT
	423		
	424		
	425		
	426		
	427		
	428		
36	429	IO6	OUT71: IO5 DOUT OE
	430		
	431		
	432		
	433		
	434		
	435		
37	436	IO6	OUT72: IO6 DOUT
	437		
	438		
	439		
	440		
	441		
	442		
38	443	Programmable Trim Block0	OUT73: IO6 DOUT OE
	444		
	445		
	446		
	447		
	448		
	449		
38	450	Programmable Trim Block0	OUT74: set0 of Auto Calibration
	451		
	452		
	453		
	454		
	455		
38	450	Programmable Trim Block0	OUT75: clock0 of Auto Calibration
	451		
	452		
	453		
	454		
	455		

SLG47004

GreenPAK Programmable Mixed-Signal Matrix with In-System Programmability and Advanced Analog Features

Table 69: Register Map (Continued)

Address		Signal Function	Register Bit Definition
Byte	Register Bit		
39	456	Programmable Trim Block0	OUT76: reload0 of Auto Calibration
	457		
	458		
	459		
	460		
	461		
	462		
3A	463	Digital Rheostat	OUT77: program0 of Auto Calibration
	464		
	465		
	466		
	467		
	468		
	469		
3B	470	Programmable Trim Block1	OUT78: Rheostat Counter0 up/down 0: down, 1: up. (register [920] = 0) 0: up, 1: down. (register [920] = 1)
	471		
	472		
	473		
	474		
	475		
	476		
3C	477	Programmable Trim Block1	OUT79: set1 of Auto Calibration
	478		
	479		
	480		
	481		
	482		
	483		
3D	484	Digital Rheostat	OUT80: clock1 of Auto Calibration
	485		
	486		
	487		
	488		
	489		
	490		
3E	491	Digital Rheostat	OUT81: reload1 of Auto Calibration
	492		
	493		
	494		
	495		
	496		
	497		
3E	498	Digital Rheostat	OUT82: program1 of Auto Calibration
	499		
	500		
	501		
	502		
	503		
	503		
3E	498	Digital Rheostat	OUT83: Rheostat Counter1 up/down 0: down, 1: up. (register [923] = 0) 0: up, 1: down. (register [923] = 1)
	499		
	500		
	501		
	502		
	503		
	503		

SLG47004

GreenPAK Programmable Mixed-Signal Matrix with In-System Programmability and Advanced Analog Features

Table 69: Register Map (Continued)

Address		Signal Function	Register Bit Definition
Byte	Register Bit		
3F	504	FIFO Reset of PT blocks	OUT84: FIFO nRST of the control logic of reload0/reload1/auto program0/auto program1
	505		
	506		
	507		
	508		
	509		
	510		
40	511	Chopper ACMP	OUT85: Chopper ACMP Power Up
	512		
	513		
	514		
	515		
	516		
	517		
41	518	Digital Rheostat	OUT86: Rheostat Charge pump enable
	519		
	520		
	521		
	522		
	523		
	524		
42	525	Analog Switch0	OUT87: ASW0 enable/Half bridge enable
	526		
	527		
	528		
	529		
	530		
	531		
43	532	Analog Switch1	OUT88: ASW1 enable/Half bridge data
	533		
	534		
	535		
	536		
	537		
	538		
44	539	ACMP0	OUT89: ACMP0 Power Up
	540		
	541		
	542		
	543		
	544		
	545		
44	546	ACMP1	OUT90: ACMP1 Power Up
	547		
	548		
	549		
	550		
	551		
	44		
552			
553			
554			
555			
556			
557			

SLG47004

GreenPAK Programmable Mixed-Signal Matrix with In-System Programmability and Advanced Analog Features

Table 69: Register Map (Continued)

Address		Signal Function	Register Bit Definition
Byte	Register Bit		
45	552	OSC1	OUT92: OSC1 ENABLE
	553		
	554		
	555		
	556		
	557		
	558		
46	559	OSC2	OUT93: OSC2 ENABLE
	560		
	561		
	562	Temperature Sensor	OUT94: VREFO TEMPSEN/VREFO Power Up
	563		
	564		
	565		
47	566	HDBUF	OUT95: HDBUF ENABLE
	567		
	568		
	569		
	570		
	571		
	572		
48	573	Op Amp0	OUT96: OP0(Op Amp ACMP0) Power Up
	574		
	575		
	576	Op Amp1	OUT97: OP1(Op Amp ACMP1) Power Up
	577		
	578		
	579		
49	580	Op Amp2	OUT98: OP2 Power Up (In Amp Mode)
	581		
	582		
	583	Op amps	OUT99: OP VREF ENABLE
	584		
	585		
	586		
4A	587	Op amps	OUT99: OP VREF ENABLE
	588		
	589		
4A	590	Op amps	OUT99: OP VREF ENABLE
	591		
	592		
	593		
	594		
	595		
	596		
597			
4A	598	Op amps	OUT99: OP VREF ENABLE
	599		
	599		

SLG47004

GreenPAK Programmable Mixed-Signal Matrix with In-System Programmability and Advanced Analog Features

Table 69: Register Map (Continued)

Address		Signal Function	Register Bit Definition
Byte	Register Bit		
4B	600	Reserved	
	601	Reserved	
	602	Reserved	
	603	Reserved	
	604	Reserved	
	605	Reserved	
	606	Reserved	
	607	Reserved	
ACMP0			
4C	608	ACMP Low Energy Power Up enable (ACMP power after bg_ok)	1: enable
	609	ACMP input path LPF enable	1: enable
	610	ACMP sampling mode enable	1: enable
	611	ACMP short time wake sleep mode disable	0: short time wake sleep enable 1: short time wake sleep disable
	612	ACMP wake sleep function enable	1: enable
	613	ACMP Vref path LPF enable (when ACMP hysteresis > 196 mV)	1: enable
	614	ACMP input divider selection	00: 1
			01: 0.5 10: 1/3 11: 1/4
4D	616	ACMP input mux selection	00: OP0 output
	617		01: from Pin 10: tie VDD
	618	ACMP Low to High Vref selection	000000-111111: 32 mV ~2.048 V/step = 32 mV
	619		
	620		
	621		
	622		
623			
4E	624	ACMP High to Low Vref selection	000000-111111: 32 mV ~2.048 V/step = 32 mV
	625		
	626		
	627		
	628		
	629		
ACMP1			
4E	630	ACMP Low Energy Power Up enable (ACMP power after bg_ok)	1: enable
	631	ACMP input path LPF enable	1: enable
4F	632	ACMP sampling mode enable	1: enable
	633	ACMP short time wake sleep mode disable	0: short time wake sleep enable 1: short time wake sleep disable
	634	ACMP wake sleep function enable	1: enable
	635	ACMP Vref path LPF enable (when ACMP hysteresis > 196 mV)	1: enable
	636	ACMP input divider selection	00: 1
			01: 0.5
			10: 1/3 11: 1/4

SLG47004

GreenPAK Programmable Mixed-Signal Matrix with In-System Programmability and Advanced Analog Features

Table 69: Register Map (Continued)

Address		Signal Function	Register Bit Definition
Byte	Register Bit		
4F	638	ACMP input mux selection	00: OP1 output 01: from Pin 10: ACMP0 input mux output 11: VrefO1 Temp sensor output
	639		
50	640	ACMP Low to High Vref selection	000000-111111: 32 mV ~2.048 V/step = 32 mV
	641		
	642		
	643		
	644		
	645		
51	646	ACMP High to Low Vref selection	000000-111111: 32 mV ~2.048 V/step = 32 mV
	647		
	648		
	649		
51	649	ACMP High to Low Vref selection	000000-111111: 32 mV ~2.048 V/step = 32 mV
	650		
	651		
	651		
Vref			
51	652	Reserved	
	653	Reserved	
	654	Reserved	
	655	Reserved	
52	656	Reserved	
	657	Reserved	
	658	VREFO0 input source selection	0: ACMP0 VREF 1: Temp Sensor
	659	VREFO0 output buffer enable	1: enable
	660	VREFO0 register Power Up	VREFO0 register power on signal
	661	VREFO0 Power Up selection	0: Power Up from reg 1: from matrix
	662	Reserved	no use
53	663	VREFO1's temp sensor to ACMP1 input path enable	Temp Sensor output to ACMP1 enable 1: enable
	664	VREFO1's temp sensor range selection	0:1V; 1:1.2V
	665	VREFO1 input source selection	0: ACMP1 Vref 1: TS
	666	VREFO1 output buffer enable	1: enable
	667	VREFO1 register Power Up	VrefO1 register power on signal
	668	VREFO1 Power Up selection	0: Power Up from reg 1: from matrix
	669	ACMP Vrefs source selection	ACMP Vref gen source selection (0: VBG, 1: V _{DD})
	670	ACMP0 external Vref enable	1:enable
	671	ACMP1 external Vref enable	1:enable
	54	672	Reserved
54	673	Reserved	
	674	Reserved	

SLG47004

GreenPAK Programmable Mixed-Signal Matrix with In-System Programmability and Advanced Analog Features

Table 69: Register Map (Continued)

Address		Signal Function	Register Bit Definition
Byte	Register Bit		
54	675	Reserved	
	676		
	677		
	678	Reserved	
	679	Reserved	
55	680	Reserved	
	681	Reserved	
	682	Reserved	
	683	Reserved	
	684	Reserved	
	685	Reserved	
	686	Reserved	
	687	Reserved	
OSC1			
56	688	OSC1 turn on by register	when matrix output enable/pd control signal = 0: 0: auto on by delay cells 1: always on
	689	OSC1 matrix power down or on select	0: matrix down 1: matrix on
	690	OSC1 external clock source enable	0: internal OSC1 1: external clock from Pin15
	691	OSC1 post divider ratio control	00: div 1 01: div 2 10: div 4 11: div8
	692		
	693	OSC1 matrix divider ratio control	000: /1 001: /2 010: /4 011: /3 100: /8 101: /12 110: /24 111: /64
	694		
	695		
57	696	OSC1 matrix out enable	0: disable 1: enable
	697	Reserved	
	698	Reserved	
	699	Reserved	
	700	OSC1 2nd output to matrix enable	0: disable 1: enable
	701	OSC1 2nd matrix divider ratio control	000: /1 001: /2 010: /4 011: /3 100: /8 101: /12 110: /24 111: /64
	702		
703			
OSC2			

SLG47004

GreenPAK Programmable Mixed-Signal Matrix with In-System Programmability and Advanced Analog Features

Table 69: Register Map (Continued)

Address		Signal Function	Register Bit Definition
Byte	Register Bit		
58	704	OSC2 turn on by register	when matrix output enable/pd control signal = 0: 0: auto on by delay cells 1: always on
	705	OSC2 matrix power down or on select	0: matrix down 1: matrix on
	706	OSC2 external clock source enable	0: internal OSC2 1: external clock from IO2
	707	OSC2 matrix out enable	0: disable 1: enable
	708	OSC2 post divider ratio control	00: div 1 01: div 2 10: div 4 11: div8
	709		000: /1 001: /2 010: /4 011: /3 100: /8 101: /12 110: /24 111: /64
	710		
	711		
59	712	OSC2 matrix divider ratio control	000: /1 001: /2 010: /4 011: /3 100: /8 101: /12 110: /24 111: /64
	713	OSC2 startup delay with 100ns	0: enable 1: disable
	714	Reserved	
	715	Reserved	
	716	Reserved	
	717	Op Amp0 sr boost for OP 8 MHz	0: enable, 1: disable
	718	Op Amp1 sr boost for OP 8 MHz	0: enable, 1: disable
	719	Op Amp2 sr boost for OP 8 MHz	0: enable, 1: disable
OSC0			
5A	720	OSC0 turn on by register	when matrix output enable/pd control signal = 0: 0: auto on by delay cells 1: always on
	721	OSC0 matrix power down or on select	0: matrix down 1: matrix on
	722	OSC0 external clock source enable	0: internal OSC0 1: external clock from IO0
	723	OSC0 matrix out enable	0: disable 1: enable
	724	OSC0 post divider ratio control	00: div 1 01: div 2 10: div 4 11: div8
	725		000: /1 001: /2 010: /4 011: /3 100: /8 101: /12 110: /24 111: /64
	726		
	727		
5B	728	OSC0 matrix divider ratio control	000: /1 001: /2 010: /4 011: /3 100: /8 101: /12 110: /24 111: /64

SLG47004

GreenPAK Programmable Mixed-Signal Matrix with In-System Programmability and Advanced Analog Features

Table 69: Register Map (Continued)

Address		Signal Function	Register Bit Definition	
Byte	Register Bit			
5B	729	enable OSC0 output gating by wake_sleep signal (note: the wake_sleep clock is separated path, so it is not gated)	0: no gating 1: enable	
	730	OSC0 2nd output to matrix enable	0: disable 1: enable	
	731	OSC0 2nd matrix divider ratio control	000: /1	
	732		001: /2	
	733		010: /4	
			011: /3	
	734	100: /8		
101: /12				
735	110: /24			
	735	111: /64		
	734	Reserved		
	735	Reserved		
Analog Switch				
5C	736	ASW0 small NMOS enable selection	0: small NMOS disable 1: small NMOS enable by matrix87	
	737	ASW1 small PMOS enable selection	0: small PMOS disable 1: small PMOS enable by matrix88	
	738	ASW0 big PMOS control selection	0: control by matrix87 1: control by Op Amp0	
	739	ASW1 big NMOS control selection	0: control by matrix88 1: control by Op Amp1	
	740	ASW half bridge mode enable	0: analog switch mode 1: half bridge (enable from matrix87; data from matrix88)	
	741	ASW half bridge dead time select	00: bypass	
	742		01: 20ns	
		743	10: 100ns	
		11: 500ns		
	743	Reserved		
Op Amp0/1/2				
5D	744	Op Amp0 bandwidth selection	00: 128 kHz	
	745		01: 512 kHz	
	746	Op Amp1 bandwidth selection	10: 2 MHz	
	747		11: 8 MHz	
	748	Op Amp2 bandwidth selection	00: 128 kHz	
	749		01: 512 kHz	
		750	10: 2 MHz	
		751	11: 8 MHz	
	750	ACMP/Op Amp0 mode	0: Op amp mode 1: ACMP mode	
	751	ACMP/Op Amp1 mode	0: Op amp mode 1: ACMP mode	
5E	752	Op Amp0 charge pump disable	0: Op amp input common voltage higher than $V_{DD}-1.5V$, enable CP 1: Op amp input common voltage lower than $V_{DD}-1.5V$, disable CP	

Table 69: Register Map (Continued)

Address		Signal Function	Register Bit Definition
Byte	Register Bit		
5E	753	Op Amp1 charge pump disable	0: Op amp input common voltage higher than $V_{DD}-1.5V$, enable CP; 1: Op amp input common voltage lower than $V_{DD}-1.5V$, disable CP
	754	Op Amp2 charge pump disable	0: Op amp input common voltage higher than $V_{DD}-1.5V$, enable CP 1: Op amp input common voltage lower than $V_{DD}-1.5V$, disable CP
	755	Path between Op Amp0/1 and Op Amp2	0: path on (for normal function) 1: path off (for trim function)
	756	Op Amp2's Vref buffer bypass control	0: without buffer 1: with buffer
	757	Supporting blocks for Op Amp0 on/off	0: on/off follows op amp 1: always on except input common voltage of op amp lower than $V_{DD}-1.5V$
	758	Supporting blocks for Op Amp1 on/off	0: on/off follows op amp 1: always on except input common voltage of op amp lower than $V_{DD}-1.5V$
	759	Supporting blocks for Op Amp2 on/off	0: on/off follows op amp 1: always on except input common voltage of op amp lower than $V_{DD}-1.5V$
5F	760	Op amp ACMP Vref0 output selection[0]	000000-111111: 32 mV ~2.048 V/step = 32 mV
	761	Op amp ACMP Vref0 output selection[1]	
	762	Op amp ACMP Vref0 output selection[2]	
	763	Op amp ACMP Vref0 output selection[3]	
	764	Op amp ACMP Vref0 output selection[4]	
	765	Op amp ACMP Vref0 output selection[5]	
	766	Op amp ACMP Vref0 register enable (select by register [782])	0: dynamic on/off 1: Vref enable
	767	Vref0 to op amp/ACMP input enable	0:disable; 1: enable
60	768	Op amp ACMP Vref1 output selection[0]	000000-111111: 32 mV ~2.048 V/step = 32 mV
	769	Op amp ACMP Vref1 output selection[1]	
	770	Op amp ACMP Vref1 output selection[2]	
	771	Op amp ACMP Vref1 output selection[3]	
	772	Op amp ACMP Vref1 output selection[4]	
	773	Op amp ACMP Vref1 output selection[5]	
	774	Op amp ACMP Vref1 register enable (select by register [783])	0: dynamic on/off 1: Vref enable
775	Vref1 to op amp/ACMP input enable	0:disable; 1: enable	
61	776	Op amp ACMP Vref0 output selection	0: Vref to ACMP negative input 1: Vref to ACMP positive input
	777	Op amp ACMP Vref1 output selection	0: Vref to ACMP negative input 1: Vref to ACMP positive input
	778	Reserved	
	779	Reserved	
	780	Op amp ACMP Vref0 input voltage selection	0: 2.048 V 1: V_{DD}
	781	Op amp ACMP Vref1 input voltage selection	0: 2.048 V 1: V_{DD}
	782	Op amp ACMP vref0 enable selection	0: from register [766] 1: from matrix99
61	783	Op amp ACMP vref1 enable selection	0: from register [774] 1: from matrix99

SLG47004

GreenPAK Programmable Mixed-Signal Matrix with In-System Programmability and Advanced Analog Features

Table 69: Register Map (Continued)

Address		Signal Function	Register Bit Definition
Byte	Register Bit		
3-bit LUT2/DFF5			
62	784	3-bit LUT2_DFF5 setting	<2:0>: 3-bit LUT2 <2:0> <3>:3-bit LUT2 <3>/DFF5 Active level selection for RST/SET 0: Active low level reset/set, 1: Active high level reset/set <4>:3-bit LUT2<4>/DFF5 0: RSTB from Matrix Output, 1: SETB from Matrix Output <5>:3-bit LUT2 <5>/DFF5 Initial Polarity Select 0: Low, 1: High <6>:3-bit LUT2 <6>/DFF5 Output Select 0: Q output, 1: QB output <7>:3-bit LUT2 <7>/DFF5 or Latch Select 0: DFF function, 1: Latch function
	785		
	786		
	787		
	788		
	789		
	790		
	791		
3-bit LUT3/DFF6			
63	792	3-bit LUT3_DFF6 setting	<2:0>: 3-bit LUT3 <2:0> <3>:3-bit LUT3 <3>/DFF6 Active level selection for RST/SET 0: Active low level reset/set, 1: Active high level reset/set <4>:3-bit LUT3<4>/DFF6 0: RSTB from Matrix Output, 1: SETB from Matrix Output <5>:3-bit LUT3 <5>/DFF6 Initial Polarity Select 0: Low, 1: High <6>:3-bit LUT3 <6>/DFF6 Output Select 0: Q output, 1: QB output <7>:3-bit LUT3 <7>/DFF6 or Latch Select 0: DFF function, 1: Latch function
	793		
	794		
	795		
	796		
	797		
	798		
	799		
3-bit LUT4/DFF7			
64	800	3-bit LUT4_DFF7 setting	<2:0>: 3-bit LUT4 <2:0> <3>:3-bit LUT4 <3>/DFF7 Active level selection for RST/SET 0: Active low level reset/set, 1: Active high level reset/set <4>:3-bit LUT4<4>/DFF7 0: RSTB from Matrix Output, 1: SETB from Matrix Output <5>:3-bit LUT4 <5>/DFF7 Initial Polarity Select 0: Low, 1: High <6>:3-bit LUT4 <6>/DFF7 Output Select 0: Q output, 1: QB output
	801		
	802		
	803		
	804		
	805		
	806		
64	807	3-bit LUT4_DFF7 setting	<7>:3-bit LUT4 <7>/DFF7 or Latch Select 0: DFF function, 1: Latch function
3-bit LUT5/DFF8			

SLG47004

GreenPAK Programmable Mixed-Signal Matrix with In-System Programmability and Advanced Analog Features

Table 69: Register Map (Continued)

Address		Signal Function	Register Bit Definition
Byte	Register Bit		
65	808	3-bit LUT5_DFF8 setting	<2:0>: 3-bit LUT5 <2:0>
	809		
	810		
	811		<3>:3-bit LUT5 <3>/DFF8 Active level selection for RST/SET 0: Active low level reset/set, 1: Active high level reset/set
	812		<4>:3-bit LUT5<4>/DFF8 0: RSTB from Matrix Output, 1: SETB from Matrix Output
	813		<5>:3-bit LUT5 <5>/DFF8 Initial Polarity Select 0: Low, 1: High
	814		<6>:3-bit LUT5 <6>/DFF8 Output Select 0: Q output, 1: QB output
815	<7>:3-bit LUT5 <7>/DFF8 or Latch Select 0: DFF function, 1: Latch function		
3-bit LUT6/DFF9			
66	816	3-bit LUT6_DFF9 setting	<2:0>: 3-bit LUT6 <2:0>
	817		
	818		
	819		<3>:3-bit LUT6 <3>/DFF9 Active level selection for RST/SET 0: Active low level reset/set, 1: Active high level reset/set
	820		<4>:3-bit LUT6<4>/DFF9 0: RSTB from Matrix Output, 1: SETB from Matrix Output
	821		<5>:3-bit LUT6 <5>/DFF9 Initial Polarity Select 0: Low, 1: High
	822		<6>:3-bit LUT6 <6>/DFF9 Output Select 0: Q output, 1: QB output
823	<7>:3-bit LUT6 <7>/DFF9 or Latch Select 0: DFF function, 1: Latch function		
67	824	3-bit LUT2 or DFF5 Select	0: 3-bit LUT2 1: DFF5
	825	3-bit LUT3 or DFF6 Select	0: 3-bit LUT3 1: DFF6
	826	3-bit LUT4 or DFF7 Select	0: 3-bit LUT4 1: DFF7
	827	3-bit LUT5 or DFF8 Select	0: 3-bit LUT5 1: DFF8
	828	3-bit LUT6 or DFF9 Select	0: 3-bit LUT6 1: DFF8
	829	4-bit LUT0 or DFF10 Select	0: 4-bit LUT0 1: DFF10
	830	Reserved	
831	Reserved		
4-bit LUT0/DFF10			

SLG47004

GreenPAK Programmable Mixed-Signal Matrix with In-System Programmability and Advanced Analog Features

Table 69: Register Map (Continued)

Address		Signal Function	Register Bit Definition	
Byte	Register Bit			
68	832	4-bit LUT0_DFF10 setting	<9:0>: 4-bit LUT0 <9:0>	
	833			
	834			
	835			
	836			
	837			
	838			
	839			
69	840			<10>:4-bit LUT0 <10>/DFF10 stage selection 0: Q of first DFF; 1 Q of second DFF <11>:4-bit LUT0 <11>/DFF10 Active level selection for RST/SET 0: Active low level reset/set, 1: Active high level reset/set <12>:4-bit LUT0 <12>/DFF10 0: RSTB from Matrix Output, 1: SETB from Matrix Output <13>:4-bit LUT0 <13> /DFF10 Initial Polarity Select 0: Low, 1: High <14>:4-bit LUT0 <14>/DFF10 Output Select 0: Q output, 1: QB output <15>:4-bit LUT0 <15>/DFF10 or Latch Select 0: DFF function, 1: Latch function
	841			
	842			
	843			
	844			
	845			
	846			
847				
3-bit LUT13/Pipe Delay (RIPP CNT)				
6A	848	LUT value or pipe delay out sel or nSET/END value	at LUT/pipe delay mode bit<7:4>: 3-bit LUT13 <7:4> / REG_S1<3:0> pipe delay out1 sel bit<3:0>: 3-bit LUT13 <3:0> / REG_S0<3:0> pipe delay out0 sel at RIPP CNT mode bit<2:0> is the nSET value. bit<5:3> is the END value bit<6> is the range control: 0: full cycle, 1: range cycle bit<7> No used	
	849			
	850			
	851			
	852			
	853			
	854			
	855			
6B	856	Active level selection for RST/SET	0: Active low level reset/set 1: Active high level reset/set	
	857	Out of 3-bit LUT13 or Out0 of Pipe Delay/RIPP CNT Select	0: 3-bit LUT13 1: OUT0 of Pipe Delay or RIPP CNT	
	858	PIPE_RIPP_CNT_S	0: Pipe delay mode selection 1: Ripple Counter mode selection	
	859	Pipe Delay OUT1 Polarity Select	0: Non-inverted 1: Inverted	
	860	Reserved		
	861	Reserved		
	862	Reserved		
863	Reserved			
Programmable Delay				

SLG47004

GreenPAK Programmable Mixed-Signal Matrix with In-System Programmability and Advanced Analog Features

Table 69: Register Map (Continued)

Address		Signal Function	Register Bit Definition
Byte	Register Bit		
6C	864	Delay Value Select for Programmable Delay & Edge Detector	00: 125ns 01: 250ns 10: 375ns 11: 500ns
	865		
	866	Select the Edge Mode of Programmable Delay & Edge Detector	00: Rising Edge Detector 01: Falling Edge Detector 10: Both Edge Detector 11: Both Edge Delay
	867		
Filter/Edge Detector			
6C	868	Filter or Edge Detector selection	0: filter 1: edge detect
	869	Output Polarity Select	0: output non-invert 1: output invert
	870	Select the edge mode	00: Rising Edge Detect 01: Falling Edge Detect 10: Both Edge Detect 11: Both Edge DLY
			871
Chopper ACMP			
6D	872	Chopper ACMP positive input selection for calibration channel0	00: from In Amp out 01: from Op Amp0 out 10: from Op Amp1 out 11: IO1
	873		
	874	Chopper ACMP positive input selection for calibration channel1	00: from In Amp out 01: from Op Amp0 out 10: from Op Amp1 out 11: IO1
	875		
	876	Reserved	
	877	Reserved	
	878	Reserved	
	879	Reserved	
6E	880	Reserved	
	881	Reserved	
	882	Output Polarity Select	0: output non-invert 1: output invert
	883	Reserved	
	884		
	885		
	886		
887			
6F	888	Reserved	
	889		
	890	Reserved	
	891	Reserved	
Calibration			

SLG47004

GreenPAK Programmable Mixed-Signal Matrix with In-System Programmability and Advanced Analog Features

Table 69: Register Map (Continued)

Address		Signal Function	Register Bit Definition
Byte	Register Bit		
6F	892	auto calibration channel selection by register	0: calibration channel0 1: calibration channel1
	893	auto calibration channel selection source selection	0: calibration channel auto selection 1: from register [892]
	894	RH_CNT1 clock source selection	0: From Chopper ACMP (Chopper ACMP changes one time per rheostat clock) 1: from matrix directly
	895	RH_CNT0 clock source selection	0: From Chopper ACMP (Chopper ACMP changes one time per rheostat clock) 1: from matrix directly
70	896	Calibration0 clock divider	0000: Reserved
	897		0001: Reserved
	898		0010: OSC1/64
			0011: OSC1/512
			0100: OSC0
			0101: OSC0/8
			0110: OSC0/64
	899		0111: OSC0/512 1000: OSC0/4096 1001: OSC0/32768 1010: OSC0/262144 1011/1100/1101/1110: GND 1111: EXTCLK
	900	Up/down selection	0: chopper ACMP 1: matrix83
	901	auto_calibration disable	0: auto calibration enable 1: disable
	902	Reserved	
	903	Reserved	
71	904	Calibration1 clock divider	0000: Reserved
	905		0001: Reserved
	906		0010: OSC1/64
			0011: OSC1/512
			0100: OSC0
			0101: OSC0/8
			0110: OSC0/64
	907		0111: OSC0/512 1000: OSC0/4096 1001: OSC0/32768 1010: OSC0/262144 1011/1100/1101/1110: GND 1111: EXTCLK
	908	Up/down selection	0: chopper ACMP 1: matrix83
	909	auto_calibration disable	0: auto calibration enable 1: disable
	910	Reserved	
	911	Reserved	
Digital Rheostats			

Table 69: Register Map (Continued)

Address		Signal Function	Register Bit Definition	
Byte	Register Bit			
72	912	POTCP0 turn on by register	0: control by matrix86 1: on	
	913	POTCP1 turn on by register	0: control by matrix86 1: on	
	914	POTCP0/1 clock source selection	0: from LPBG chopper OSC 1: from OSC1	
	915	POTCP0/1 clock source select from register	0: by register [914] 1: calibration auto on	
	916	Reserved		
	917	Reserved		
	918	Reserved		
73	919	Reserved		
	920	Polarity selection of RH_CNT0 UP signal	0: default (up = 0 down mode, up = 1 up mode) 1: (up = 0 up mode, up = 1 down mode)	
	921	Reserved		
	922	Reserved		
	923	Polarity selection of RH_CNT1 UP signal	0: default (up = 0 down mode, up = 1 up mode) 1: (up = 0 up mode, up = 1 down mode)	
	924	Reserved		
	925	Reserved		
74	926	Reserved		
	927	Reserved		
	HD Buffer			
	74	928	Chop ACMP Vref selection for calibration channel 0	000000-111111: 1/64 ~ 64/64 (divider input select by register [946])
		929		
		930		
		931		
932				
933				
934	Chop ACMP calibration channel0 external Vref selection	0: external Vref (pin18) 1: internal Vref		
935	Reserved			
75	936	Chop ACMP Vref selection for calibration channel 1	000000-111111: 1/64 ~ 64/64 (divider input select by register [946])	
	937			
	938			
	939			
	940			
	941			
	942	Chop ACMP calibration channel1 external Vref selection	0: external Vref (pin18) 1: internal Vref	
943	Reserved			

SLG47004

GreenPAK Programmable Mixed-Signal Matrix with In-System Programmability and Advanced Analog Features

Table 69: Register Map (Continued)

Address		Signal Function	Register Bit Definition
Byte	Register Bit		
76	944	HD buffer register enable (select by register [945])	0: disable 1: enable
	945	HD buffer enable selection	0: from register [944] 1: from matrix95
	946	Chop ACMP Vref divider input selection	0: from HD buffer output 1: from op amp Vref voltage (2.048/V _{DD} selection register in Vref block)
	947	Reserved	
	948	Reserved	
	949	Reserved	
	950	Reserved	
	951	Reserved	
CP OSC/Regulator			
77	952	CPOSC single or multiple mode select	0: multiple OSC mode 1: single OSC mode
	953	Reserved	
	954	CPOSC0 frequency select	00: 250 kHz 01: 1 MHz 10: 4 MHz 11: 8 MHz
	955		
	956	Reserved	
	957	Reserved	
	958	Reserved	
959	Reserved		
78	960	Reserved	
	961	Reserved	
	962	CPOSC1 frequency select	00: 250 kHz 01: 1 MHz 10: 4 MHz 11: 8 MHz
	963		
	964	Reserved	
	965	Reserved	
	966	Reserved	
967	Reserved		
79	968	Reserved	
	969	Reserved	
	970	CPOSC2 frequency select	00: 250 kHz 01: 1 MHz 10: 4 MHz 11: 8 MHz
	971		
	972	Reserved	
	973	Reserved	
	974	Reserved	
975	Reserved		

SLG47004

GreenPAK Programmable Mixed-Signal Matrix with In-System Programmability and Advanced Analog Features

Table 69: Register Map (Continued)

Address		Signal Function	Register Bit Definition
Byte	Register Bit		
7A	976	Buffer Vref select	00: none
	977		01: internal Vref 10: Rheostat Vref 11: external Vref
	978	Reserved	
	979	Reserved	
	980	Reserved	
	981	Reserved	
	982	Reserved	
	983	Reserved	
7B	984	I ² C soft reset	0: Keep existing condition 1: Reset execution, reload NVM to registers
	985	IO latch enable during I ² C write	0: disable 1: enable
	986	Reserved	
	987	Reserved	
	988	Reserved	
	989	Reserved	
	990	Reserved	
	991	Reserved	
7C	992	Matrix Input 32	I ² C_virtual_0 Input
	993	Matrix Input 33	I ² C_virtual_1 Input
	994	Matrix Input 34	I ² C_virtual_2 Input
	995	Matrix Input 35	I ² C_virtual_3 Input
	996	Matrix Input 36	I ² C_virtual_4 Input
	997	Matrix Input 37	I ² C_virtual_5 Input
	998	Matrix Input 38	I ² C_virtual_6 Input
	999	Matrix Input 39	I ² C_virtual_7 Input
7D	1000	8-bit Pattern ID Byte 0 (from NVM): ID [23:16]	
	1001		
	1002		
	1003		
	1004		
	1005		
	1006		
	1007		
7E	1008	Reserved	
	1009		
	1010		
	1011		
	1012		
	1013		
	1014		
	1015		

SLG47004

GreenPAK Programmable Mixed-Signal Matrix with In-System Programmability and Advanced Analog Features

Table 69: Register Map (Continued)

Address		Signal Function	Register Bit Definition
Byte	Register Bit		
7F	1016	I ² C slave address	
	1017		
	1018		
	1019		
	1020	slave address selection bit0	0: from register [1016] 1: from Pin15
	1021	slave address selection bit1	0: from register [1017] 1: from Pin16
	1022	slave address selection bit2	0: from register [1018] 1: from Pin17
	1023	slave address selection bit3	0: from register [1019] 1: from Pin18
80	1024	Reserved	
	1025		
	1026		
	1027		
	1028		
	1029		
	1030		
	1031		
81	1032	Reserved	
	1033		
	1034		
	1035		
	1036		
	1037		
	1038	Reserved	
	1039	Reserved	
82	1040	Reserved	
	1041		
	1042		
	1043		
	1044		
	1045		
	1046	Reserved	
	1047	Reserved	
83	1048	Reserved	
	1049		
	1050		
	1051		
	1052		
	1053		
	1054	Reserved	
	1055	Reserved	

SLG47004

GreenPAK Programmable Mixed-Signal Matrix with In-System Programmability and Advanced Analog Features

Table 69: Register Map (Continued)

Address		Signal Function	Register Bit Definition
Byte	Register Bit		
84	1056	Reserved	
	1057		
	1058		
	1059		
	1060		
	1061		
	1062		
85	1063	Reserved	
	1064		
	1065		
	1066		
	1067		
	1068		
	1069		
86	1070	Reserved	
	1071		
	1072		
	1073		
	1074		
	1075		
	1076		
87	1077	Reserved	
	1078		
	1079		
	1080		
	1081		
	1082		
	1083		
88	1084	Reserved	
	1085		
	1086		
	1087		
	1088		
	1089		
	1090		
88	1091	Reserved	
	1092		
	1093		
	1094		
	1095		

SLG47004

GreenPAK Programmable Mixed-Signal Matrix with In-System Programmability and Advanced Analog Features

Table 69: Register Map (Continued)

Address		Signal Function	Register Bit Definition
Byte	Register Bit		
89	1096	Reserved	
	1097		
	1098		
	1099		
	1100		
	1101		
	1102		
8A	1103	Reserved	
	1104		
	1105		
	1106		
	1107		
	1108		
	1109		
8B	1110	Reserved	
	1111		
	1112		
	1113		
	1114		
	1115		
	1116		
8C	1117	Reserved	
	1118		
	1119		
	1120		
	1121		
	1122		
	1123		
8D	1124	Reserved	
	1125		
	1126		
	1127		
	1128		
	1129		
	1130		
8E	1131	Reserved	
	1132		
	1133		
	1134		
	1135		
	1136		
	1137		
8E	1138	Reserved	
	1139		
	1140		

SLG47004

GreenPAK Programmable Mixed-Signal Matrix with In-System Programmability and Advanced Analog Features

Table 69: Register Map (Continued)

Address		Signal Function	Register Bit Definition
Byte	Register Bit		
8E	1141	Reserved	
	1142		
	1143		
8F	1144	Reserved	
	1145		
	1146		
	1147		
	1148	Reserved	
	1149		
	1150		
	1151	Reserved	
SCL/SDA			
90	1152	I ² C SCL/SDA input mode select bits (for low voltage in purpose)	00: digital without Schmitt trigger
	1153		01: digital with Schmitt trigger
	1154	Reserved	10: low voltage digital in
	1155	I ² C mode selection	11: analog IO
			0: I ² C fast mode +
			1: I ² C standard/fast mode
IO0			
90	1156	input mode configuration	00: digital without Schmitt Trigger
	1157		01: digital with Schmitt Trigger
	1158	output mode configuration	10: low voltage digital in
	1159		11: analog IO
			00: Push-Pull 1x
			01: Push-Pull 2x
			10: 1x Open-Drain
			11: 2x Open-Drain
91	1160	Pull-up/down resistance selection	00: floating
	1161		01: 10k
	1162	Pull-up/down selection	10: 100k
			11: 1M
			0: Pull-down
			1: Pull-up
IO1			
91	1163	input mode configuration	00: digital without Schmitt Trigger
	1164		01: digital with Schmitt Trigger
	1165	output mode configuration	10: low voltage digital in
	1166		11: analog IO
	1167		00: Push-Pull 1x
			01: Push-Pull 2x
			10: 1x Open-Drain
			11: 2x Open-Drain
92	1168	Pull-up/down resistance selection	00: floating
	1169	Pull-up/down selection	01: 10K
			10: 100K
			11: 1M
			0: Pull-down
			1: Pull-up
IO2			

SLG47004

GreenPAK Programmable Mixed-Signal Matrix with In-System Programmability and Advanced Analog Features

Table 69: Register Map (Continued)

Address		Signal Function	Register Bit Definition
Byte	Register Bit		
92	1170	input mode configuration	00: digital without Schmitt Trigger
	1171		01: digital with Schmitt Trigger
	1172	output mode configuration	10: low voltage digital in
	1173		11: analog IO
	1174		00: Push-Pull 1x
1175	Pull-up/down resistance selection	01: Push-Pull 2x	
1176		10: 1x Open-Drain	
93	1176	Pull-up/down selection	11: 2x Open-Drain
IO3			
93	1177	input mode configuration	00: digital without Schmitt Trigger
	1178		01: digital with Schmitt Trigger
	1179	output mode configuration	10: low voltage digital in
	1180		11: analog IO
	1181		00: Push-Pull 1x
	1182	Pull-up/down resistance selection	01: Push-Pull 2x
1183	10: 1x Open-Drain		
	1183	Pull-up/down selection	11: 2x Open-Drain
IO4			
94	1184	input mode configuration	00: digital without Schmitt Trigger
	1185		01: digital with Schmitt Trigger
	1186	output mode configuration	10: low voltage digital in
	1187		11: analog IO
	1188		00: Push-Pull 1x
	1189	Pull-up/down resistance selection	01: Push-Pull 2x
1190	10: 1x Open-Drain		
	1190	Pull-up/down selection	11: 2x Open-Drain
IO5			

SLG47004

GreenPAK Programmable Mixed-Signal Matrix with In-System Programmability and Advanced Analog Features

Table 69: Register Map (Continued)

Address		Signal Function	Register Bit Definition				
Byte	Register Bit						
94	1191	input mode configuration	00: digital without Schmitt Trigger 01: digital with Schmitt Trigger 10: low voltage digital in 11: analog IO				
95	1192		output mode configuration	00: Push-Pull 1x 01: Push-Pull 2x 10: 1x Open-Drain 11: 2x Open-Drain			
	1193			Pull-up/down resistance selection	00: floating 01: 10K 10: 100K 11: 1M		
	1194				Pull-up/down selection	0: Pull-down 1: Pull-up	
	1195					input mode configuration	00: digital without Schmitt Trigger 01: digital with Schmitt Trigger 10: low voltage digital in 11: analog IO
	1196						output mode configuration
1197	Pull-up/down resistance selection	00: floating 01: 10K 10: 100K 11: 1M					
IO6							
95	1198	input mode configuration	00: digital without Schmitt Trigger 01: digital with Schmitt Trigger 10: low voltage digital in 11: analog IO				
	1199						
96	1200	output mode configuration	00: Push-Pull 1x 01: Push-Pull 2x 10: 1x Open-Drain 11: 2x Open-Drain				
	1201						
	1202			Pull-up/down resistance selection	00: floating 01: 10K 10: 100K 11: 1M		
	1203						
1204	Pull-up/down selection	0: Pull-down 1: Pull-up					
IO							
96	1205	input mode configuration	00: digital without Schmitt Trigger 01: digital with Schmitt Trigger 10: low voltage digital in 11: analog IO				
	1206						
	1207			IO fast Pull-up/down enable	0: disable 1: enable		
97	1208	Reserved					
	1209	Reserved					
	1210	Reserved					
	1211	Reserved					
	1212	Reserved					
	1213	Reserved					
	1214	Reserved					
1215	Reserved						

SLG47004

GreenPAK Programmable Mixed-Signal Matrix with In-System Programmability and Advanced Analog Features

Table 69: Register Map (Continued)

Address		Signal Function	Register Bit Definition
Byte	Register Bit		
98	1216	Multi0 register configure	mulit_function selection
	1217		
	1218		dly2lut selection
	1219		
	1220		output selection of 4-bit LUT1/DFF17: 0: 4-bit LUT1 1: DFF17
	1221		external clock selection
	1222		
1223			
99	1224	DLY/CNT0 Mode Selection	00: DLY 01: one shoot 10: frequency detect 11: CNT register [1238] = 0
	1225	DLY/CNT0 edge Mode Selection	00: both edge 01: falling edge
	1226		10: rising edge 11: High Level Reset (only in CNT mode)
	1227	DLY/CNT0 Clock Source Select	Clock source sel[3:0] 0000: 25M(OSC2) 0001: 25M/4 0010: 2M(OSC1) 0011: 2M/8 0100: 2M/64 0101: 2M/512 0110: 2K(OSC0) 0111: 2K/8 1000: 2K/64 1001: 2K/512 1010: 2K/4096 1011: 2K/32768 1100: 2K/262144 1101: CNT6_END 1110: External 1111: Not used
	1228		
	1229		
	1230		
1231	FSM0 SET/RST Selection		
9A	1232	wake sleep mode selection	0: Default Mode, 1: Wake Sleep Mode (registers [1224:1223] = 11)
	1233	Wake sleep power down state selection	0: low 1: high
	1234	Keep signal sync selection	0: bypass 1: after two DFF
	1235	UP signal sync selection	0: bypass 1: after two DFF
	1236	CNT0 CNT mode SYNC selection	0: bypass 1: after two DFF
	1237	CNT0 output pol selection	0: Default Output 1: Inverted Output
	1238	CNT0 DLY EDET FUNCTION Selection	0: normal 1: DLY function edge detection (registers [1224:1223] = 00)
1239	Reserved		

SLG47004

GreenPAK Programmable Mixed-Signal Matrix with In-System Programmability and Advanced Analog Features

Table 69: Register Map (Continued)

Address		Signal Function	Register Bit Definition		
Byte	Register Bit				
9B	1240	Multi1 register configure	mulit_function selection		
	1241				
	1242		dly2lut selection		
	1243				
	1244		output selection of 3-bit LUT7/DFF11: 0: 3-bit LUT7 1: DFF11		
	1245		CNT1 DLY EDET FUNCTION Selection	0: normal 1: DLY function edge detection (registers [1251:1248] = 0000/0001/0010)	
	1246		CNT1 CNT mode SYNC selection	0: bypass 1: after two DFF	
	1247		CNT1 output pol selection	0: Default Output 1: Inverted Output	
9C	1248	CNT1 function and edge mode selection	0000: both edge Delay 0001: falling edge delay 0010: rising edge delay 0011: both edge One Shot 0100: falling edge One Shot 0101: rising edge One Shot 0110: both edge freq detect 0111: falling edge freq detect 1000: rising edge freq detect 1001: both edge detect 1010: falling edge detect 1011: rising edge detect 1100: both edge reset CNT 1101: falling edge reset CNT 1110: rising edge reset CNT 1111: high level reset CNT		
	1249				
	1250				
	1251				
	1252			DLY/CNT1 Clock Source Select	Clock source sel[3:0] 0000: 25M(OSC2) 0001: 25M/4 0010: 2M(OSC1) 0011: 2M/8 0100: 2M/64 0101: 2M/512 0110: 2K(OSC0) 0111: 2K/8 1000: 2K/64 1001: 2K/512 1010: 2K/4096 1011: 2K/32768 1100: 2K/262144 1101: CNT0_END 1110: External 1111: Not used
	1253				
	1254				
	1255				

SLG47004

GreenPAK Programmable Mixed-Signal Matrix with In-System Programmability and Advanced Analog Features

Table 69: Register Map (Continued)

Address		Signal Function	Register Bit Definition	
Byte	Register Bit			
9D	1256	Multi2 register configure	mulit_function selection	
	1257			
	1258		dly2lut selection	
	1259			
	1260		output selection of 3-bit LUT8/DFF12: 0: 3-bit LUT8 1: DFF12	
	1261		CNT2 DLY EDET FUNCTION Selection	0: normal 1: DLY function edge detection (registers [1267:1264] = 0000/0001/0010)
	1262		CNT2 CNT mode SYNC selection	0: bypass 1: after two DFF
	1263		CNT2 output pol selection	0: Default Output 1: Inverted Output
9E	1264	CNT2 function and edge mode selection	0000: both edge Delay 0001: falling edge delay 0010: rising edge delay 0011: both edge One Shot 0100: falling edge One Shot 0101: rising edge One Shot 0110: both edge freq detect 0111: falling edge freq detect 1000: rising edge freq detect 1001: both edge detect 1010: falling edge detect 1011: rising edge detect 1100: both edge reset CNT 1101: falling edge reset CNT 1110: rising edge reset CNT 1111: high level reset CNT	
	1265			
	1266			
	1267			
9E	1268	DLY/CNT2 Clock Source Select	Clock source sel[3:0] 0000: 25M(OSC2) 0001: 25M/4 0010: 2M(OSC1) 0011: 2M/8 0100: 2M/64 0101: 2M/512 0110: 2K(OSC0) 0111: 2K/8 1000: 2K/64 1001: 2K/512 1010: 2K/4096 1011: 2K/32768 1100: 2K/262144 1101: CNT1_END 1110: External 1111: Not used	
	1269			
	1270			
	1271			

Table 69: Register Map (Continued)

Address		Signal Function	Register Bit Definition	
Byte	Register Bit			
9F	1272	Multi3 register configure	mulit_function selection	
	1273			
	1274		dly2lut selection	
	1275		output selection of 3-bit LUT9/DFF13: 0: 3-bit LUT9 1: DFF13	
	1276		0: normal 1: DLY function edge detection(registers [1283:1280] = 0000/0001/0010)	
	1277		CNT3 DLY EDET FUNCTION Selection	0: bypass; 1: after two DFF
	1278		CNT3 CNT mode SYNC selection	0: Default Output, 1: Inverted Output
	1279		CNT3 output pol selection	
A0	1280	CNT3 function and edge mode selection	0000: both edge Delay	
	1281		0001: falling edge delay	
	1282		0010: rising edge delay	
	1283		0011: both edge One Shot	
			0100: falling edge One Shot	
			0101: rising edge One Shot	
			0110: both edge freq detect	
			0111: falling edge freq detect	
			1000: rising edge freq detect	
			1001: both edge detect	
1010: falling edge detect				
1011: rising edge detect				
1100: both edge reset CNT				
1101: falling edge reset CNT				
1110: rising edge reset CNT				
1111: high level reset CNT				
1284	DLY/CNT3 Clock Source Select	Clock source sel[3:0]		
1285		0000: 25M(OSC2)		
1286		0001: 25M/4		
		0010: 2M(OSC1)		
1287		0011: 2M/8		
		0100: 2M/64		
		0101: 2M/512		
	0110: 2K(OSC0)			
	0111: 2K/8			
	1000: 2K/64			
	1001: 2K/512			
1010: 2K/4096				
1011: 2K/32768				
1100: 2K/262144				
1101: CNT2_END				
1110: External				
1111: Not used				

SLG47004

GreenPAK Programmable Mixed-Signal Matrix with In-System Programmability and Advanced Analog Features

Table 69: Register Map (Continued)

Address		Signal Function	Register Bit Definition		
Byte	Register Bit				
A1	1288	Multi4 register configure	mulit_function selection		
	1289				
	1290		dly2lut selection		
	1291				
	1292		output selection of 3-bit LUT10/DFF14: 0: 3-bit LUT10 1: DFF14		
	1293		CNT4 DLY EDET FUNCTION Selection	0: normal 1: DLY function edge detection (registers [1299:1296] = 0000/0001/0010)	
	1294		CNT4 CNT mode SYNC selection	0: bypass 1: after two DFF	
	1295		CNT4 output pol selection	0: Default Output 1: Inverted Output	
A2	1296	CNT4 function and edge mode selection	0000: both edge Delay 0001: falling edge delay 0010: rising edge delay 0011: both edge One Shot 0100: falling edge One Shot 0101: rising edge One Shot 0110: both edge freq detect; 0111: falling edge freq detect 1000: rising edge freq detect 1001: both edge detect 1010: falling edge detect 1011: rising edge detect 1100: both edge reset CNT 1101: falling edge reset CNT 1110: rising edge reset CNT 1111: high level reset CNT		
	1297				
	1298				
	1299				
	1300			DLY/CNT4 Clock Source Select	Clock source sel[3:0] 0000: 25M(OSC2) 0001: 25M/4 0010: 2M(OSC1) 0011: 2M/8 0100: 2M/64 0101: 2M/512 0110: 2K(OSC0) 0111: 2K/8 1000: 2K/64 1001: 2K/512 1010: 2K/4096 1011: 2K/32768 1100: 2K/262144 1101: CNT3_END 1110: External 1111: Not used
	1301				
	1302				
	1303				

Table 69: Register Map (Continued)

Address		Signal Function	Register Bit Definition		
Byte	Register Bit				
A3	1304	Multi5 register configure	mulit_function selection		
	1305				
	1306		dly2lut selection		
	1307				
	1308		output selection of 3-bit LUT11/DFF15: 0: 3-bit LUT11 1: DFF15		
	1309		CNT5 DLY EDET FUNCTION Selection	0: normal 1: DLY function edge detection (registers [1315:1312] = 0000/0001/0010)	
	1310		CNT5 CNT mode SYNC selection	0: bypass 1: after two DFF	
	1311		CNT5 output pol selection	0: Default Output 1: Inverted Output	
A4	1312	CNT5 function and edge mode selection	0000: both edge Delay 0001: falling edge delay 0010: rising edge delay 0011: both edge One Shot 0100: falling edge One Shot 0101: rising edge One Shot 0110: both edge freq detect 0111: falling edge freq detect 1000: rising edge freq detect 1001: both edge detect 1010: falling edge detect 1011: rising edge detect 1100: both edge reset CNT 1101: falling edge reset CNT 1110: rising edge reset CNT 1111: high level reset CNT		
	1313				
	1314				
	1315				
	1316			DLY/CNT5 Clock Source Select	Clock source sel[3:0] 0000: 25M(OSC2) 0001: 25M/4 0010: 2M(OSC1) 0011: 2M/8 0100: 2M/64 0101: 2M/512 0110: 2K(OSC0) 0111: 2K/8 1000: 2K/64 1001: 2K/512 1010: 2K/4096 1011: 2K/32768 1100: 2K/262144 1101: CNT4_END 1110: External 1111: Not used
	1317				
	1318				
	1319				

SLG47004

GreenPAK Programmable Mixed-Signal Matrix with In-System Programmability and Advanced Analog Features

Table 69: Register Map (Continued)

Address		Signal Function	Register Bit Definition		
Byte	Register Bit				
A5	1320	Multi6 register configure	mulit_function selection		
	1321				
	1322		dly2lut selection		
	1323				
	1324		output selection of 3-bit LUT12/DFF16: 0: 3-bit LUT12 1: DFF16		
	1325		CNT6 DLY EDET FUNCTION Selection	0: normal 1: DLY function edge detection (registers [1331:1328] = 0000/0001/0010)	
	1326		CNT6 CNT mode SYNC selection	0: bypass 1: after two DFF	
	1327		CNT6 output pol selection	0: Default Output 1: Inverted Output	
A6	1328	CNT6 function and edge mode selection	0000: both edge Delay 0001: falling edge delay 0010: rising edge delay 0011: both edge One Shot 0100: falling edge One Shot 0101: rising edge One Shot 0110: both edge freq detect 0111: falling edge freq detect 1000: rising edge freq detect 1001: both edge detect 1010: falling edge detect 1011: rising edge detect 1100: both edge reset CNT 1101: falling edge reset CNT 1110: rising edge reset CNT 1111: high level reset CNT		
	1329				
	1330				
	1331				
	1332			DLY/CNT6 Clock Source Select	Clock source sel[3:0] 0000: 25M(OSC2) 0001: 25M/4 0010: 2M(OSC1) 0011: 2M/8 0100: 2M/64 0101: 2M/512 0110: 2K(OSC0) 0111: 2K/8 1000: 2K/64 1001: 2K/512 1010: 2K/4096 1011: 2K/32768 1100: 2K/262144 1101: CNT5_END 1110: External 1111: Not used
	1333				
	1334				
	1335				

SLG47004

GreenPAK Programmable Mixed-Signal Matrix with In-System Programmability and Advanced Analog Features

Table 69: Register Map (Continued)

Address		Signal Function	Register Bit Definition
Byte	Register Bit		
A7	1336	CNT0 initial value selection	00: bypass the initial 01: initial 0 10: initial 1 11: initial 1
	1337		
	1338	CNT1 initial value selection	00:bypass the initial 01: initial 0 10: initial 1 11: initial 1
	1339		
	1340	CNT6 initial value selection	00: bypass the initial 01: initial 0 10: initial 1 11: initial 1
	1341		
	1342	Reserved	
	1343	Reserved	
A8	1344	CNT2 initial value selection	00: bypass the initial 01: initial 0 10: initial 1 11: initial 1
	1345		
	1346	CNT3 initial value selection	00: bypass the initial 01: initial 0 10: initial 1 11: initial 1
	1347		
	1348	CNT4 initial value selection	00: bypass the initial 01: initial 0 10: initial 1 11: initial 1
	1349		
	1350	CNT5 initial value selection	00:bypass the initial 01: initial 0 10: initial 1 11: initial 1
1351			
A9	1352	Multi0 4-bit LUT_DFF setting	<12:0>:4-bit LUT1 <12:0>
	1353		
	1354		
	1355		
	1356		
	1357		
	1358		
	1359		
AA	1360	Multi0 4-bit LUT_DFF setting	<13>:4-bit LUT1 <13>/DFF17 Initial Polarity Select 0: Low, 1: High
	1361		
	1362		
	1363		
	1364		
	1365		
	1366		
1367	<15>:4-bit LUT1 <15>/DFF17 or Latch Select 0: DFF function, 1: Latch function		

SLG47004

GreenPAK Programmable Mixed-Signal Matrix with In-System Programmability and Advanced Analog Features

Table 69: Register Map (Continued)

Address		Signal Function	Register Bit Definition		
Byte	Register Bit				
AB	1368	REG_CNT0_D<15:0>	Data[15:0]		
	1369				
	1370				
	1371				
	1372				
	1373				
	1374				
	1375				
AC	1376			REG_CNT0_D<15:0>	Data[15:0]
	1377				
	1378				
	1379				
	1380				
	1381				
	1382				
1383					
AD	1384	Multi1_3-bit_LUT_DFF setting	<3:0>:3-bit LUT7 <3:0>		
	1385				
	1386				
	1387				
	1388		<4>:3-bit LUT7 <4>/DFF11 Initial Polarity Select 0: Low, 1: High		
	1389		<5>:3-bit LUT7 <5>/DFF11 0: RSTB from Matrix Output, 1: SETB from Matrix Output		
	1390		<6>:3-bit LUT7 <6>/DFF11 Output Select 0: Q output, 1: QB output		
1391	<7>:3-bit LUT7 <7>/DFF11 or Latch Select 0: DFF function, 1: Latch function				
Multi1_CNT1					
AE	1392		REG_CNT1_D<7:0>	Data[7:0]	
	1393				
	1394				
	1395				
	1396				
	1397				
	1398				
	1399				
AF	1400	Multi2 3-bit LUT_DFF setting	<3:0>:3-bit LUT8 <3:0>		
	1401				
	1402				
	1403				
	1404		<4>:3-bit LUT8 <4>/DFF12 Initial Polarity Select 0: Low, 1: High		
	1405		<5>:3-bit LUT8 <5>/DFF12 0: RSTB from Matrix Output, 1: SETB from Matrix Output		
	1406		<6>:3-bit LUT8 <6>/DFF12 Output Select 0: Q output, 1: QB output		
1407	<7>:3-bit LUT8 <7>/DFF12 or Latch Select 0: DFF function, 1: Latch function				

SLG47004

GreenPAK Programmable Mixed-Signal Matrix with In-System Programmability and Advanced Analog Features

Table 69: Register Map (Continued)

Address		Signal Function	Register Bit Definition
Byte	Register Bit		
B0	1408	REG_CNT2_D<7:0>	Data[7:0]
	1409		
	1410		
	1411		
	1412		
	1413		
	1414		
	1415		
B1	1416	Multi3_3-bit_LUT_DFF setting	<3:0>:3-bit LUT9 <3:0>
	1417		<4>:3-bit LUT9 <4>/DFF13 Initial Polarity Select 0: Low, 1: High
	1418		<5>:3-bit LUT9 <5>/DFF13 0: RSTB from Matrix Output, 1: SETB from Matrix Output
	1419		<6>:3-bit LUT9 <6>/DFF13 Output Select 0: Q output, 1: QB output
	1420		<7>:3-bit LUT9 <7>/DFF13 or Latch Select 0: DFF function, 1: Latch function
	1421		
	1422		
B2	1423	REG_CNT3_D<7:0>	Data[7:0]
	1424		
	1425		
	1426		
	1427		
	1428		
	1429		
	1430		
B3	1431	Multi4_3-bit_LUT_DFF setting	<3:0>:3-bit LUT10 <3:0>
	1432		<4>:3-bit LUT10 <4>/DFF14 Initial Polarity Select 0: Low, 1: High
	1433		<5>:3-bit LUT10 <5>/DFF14 0: RSTB from Matrix Output, 1: SETB from Matrix Output
	1434		<6>:3-bit LUT10 <6>/DFF14 Output Select 0: Q output, 1: QB output
	1435		<7>:3-bit LUT10 <7>/DFF14 or Latch Select 0: DFF function, 1: Latch function
	1436		
	1437		
	1438		
B4	1439	REG_CNT4_D<7:0>	Data[7:0]
	1440		
	1441		
	1442		
	1443		
	1444		
	1445		
	1446		
	1447		

SLG47004

GreenPAK Programmable Mixed-Signal Matrix with In-System Programmability and Advanced Analog Features

Table 69: Register Map (Continued)

Address		Signal Function	Register Bit Definition
Byte	Register Bit		
B5	1448	Multi5_3-bit LUT_DFF setting	<3:0>:3-bit LUT11<3:0>
	1449		
	1450		
	1451		
	1452		<4>:3-bit LUT11<4>/DFF15 Initial Polarity Select 0: Low, 1: High
	1453		<5>:3-bit LUT11 <5>/DFF15 0: RSTB from Matrix Output, 1: SETB from Matrix Output
	1454		<6>:3-bit LUT11 <6>/DFF15 Output Select 0: Q output, 1: QB output
1455	<7>:3-bit LUT11 <7>/DFF15 or Latch Select 0: DFF function, 1: Latch function		
B6	1456	REG_CNT5_D<7:0>	Data[7:0]
	1457		
	1458		
	1459		
	1460		
	1461		
	1462		
B7	1464	Multi6_3-bit LUT_DFF setting	<3:0>:3-bit LUT12 <3:0>
	1465		
	1466		
	1467		
	1468		<4>:3-bit LUT12 <4>/DFF16 Initial Polarity Select 0: Low, 1: High
	1469		<5>:3-bit LUT12 <5>/DFF16 0: RSTB from Matrix Output, 1: SETB from Matrix Output
	1470		<6>:3-bit LUT12 <6>/DFF16 Output Select 0: Q output, 1: QB output
1471	<7>:3-bit LUT12 <7>/DFF16 or Latch Select 0: DFF function, 1: Latch function		
B8	1472	REG_CNT6_D<7:0>	Data[7:0]
	1473		
	1474		
	1475		
	1476		
	1477		
	1478		
1479			

SLG47004

GreenPAK Programmable Mixed-Signal Matrix with In-System Programmability and Advanced Analog Features

Table 69: Register Map (Continued)

Address		Signal Function	Register Bit Definition
Byte	Register Bit		
B9	1480	2-bit LUT0/DFF0 setting	<0>:2-bit LUT0 <0>
	1481		<1>:2-bit LUT0 <1>/DFF0 Initial Polarity Select 0: Low, 1: High
	1482		<2>:2-bit LUT0 <2>/DFF0 Output Select 0: Q output, 1: QB output
	1483		<3>:2-bit LUT0 <3>/DFF0 or Latch Select 0: DFF function, 1: Latch function
	1484	2-bit LUT1/DFF1 setting	<0>:2-bit LUT0 <0>
	1485		<1>:2-bit LUT0 <1>/DFF0 Initial Polarity Select 0: Low, 1: High
	1486		<2>:2-bit LUT0 <2>/DFF0 Output Select 0: Q output, 1: QB output
	1487		<3>:2-bit LUT0 <3>/DFF0 or Latch Select 0: DFF function, 1: Latch function
BA	1488	2-bit LUT2/DFF2 setting	<0>:2-bit LUT0 <0>
	1489		<1>:2-bit LUT0 <1>/DFF0 Initial Polarity Select 0: Low, 1: High
	1490		<2>:2-bit LUT0 <2>/DFF0 Output Select 0: Q output, 1: QB output
	1491		<3>:2-bit LUT0 <3>/DFF0 or Latch Select 0: DFF function, 1: Latch function
	1492	2-bit LUT0 or DFF0 Select	0: 2-bit LUT0 1: DFF0
	1493	2-bit LUT1 or DFF1 Select	0: 2-bit LUT1 1: DFF1
	1494	2-bit LUT2 or DFF2 Select	0: 2-bit LUT2 1: DFF2
	1495	Reserved	
BB	1496	PGen data	PGen Data[15:0]
	1497		
	1498		
	1499		
	1500		
	1501		
	1502		
	1503		
BC	1504		
	1505		
	1506		
	1507		
	1508		
	1509		
	1510		
	1511		

SLG47004

GreenPAK Programmable Mixed-Signal Matrix with In-System Programmability and Advanced Analog Features

Table 69: Register Map (Continued)

Address		Signal Function	Register Bit Definition	
Byte	Register Bit			
BD	1512	2-bit LUT3_VAL or PGen_data	2-bit LUT3<3:0> or PGen 4bit counter data<3:0>	
	1513			
	1514			
	1515			
	1516	2-bit LUT3 or PGen Select	0: 3-bit LUT3 1: PGen	
	1517	Active level selection for RST/SET	0: Active low level reset/set 1: Active high level reset/set	
	1518	3-bit LUT0 or DFF3 Select	0: 3-bit LUT0 1: DFF3	
	1519	3-bit LUT1 or DFF4 Select	0: 3-bit LUT1 1: DFF4	
BE	1520	3-bit LUT0_DFF3 setting	<1:0>: 3-bit LUT0 <1:0>	
	1521		<2>: 3-bit LUT0 <2>/DFF3 stage selection 0: Q of first DFF; 1 Q of second DFF	
	1522			
	1523		<3>:3-bit LUT0 <3>/DFF3 Active level selection for RST/SET 0: Active low level reset/set, 1: Active high level reset/set	
	1524		<4>:3-bit LUT0 <4>/DFF3 0: RSTB from Matrix Output, 1: SETB from Matrix Output	
	1525		<5>:3-bit LUT0 <5>/DFF3 Initial Polarity Select 0: Low, 1: High	
	1526		<6>:3-bit LUT0 <6>/DFF3 Output Select 0: Q output, 1: QB output	
	1527		<7>:3-bit LUT0 <7>/DFF3 or Latch Select 0: DFF function, 1: Latch function	
BF	1528	3-bit LUT1_DFF4 setting	<2:0>: 3-bit LUT1 <2:0>	
	1529			
	1530		<3>:3-bit LUT1 <3>/DFF4 Active level selection for RST/SET 0: Active low level reset/set, 1: Active high level reset/set	
	1531			
	1532			<4>:3-bit LUT1 <4>/DFF4 0: RSTB from Matrix Output, 1: SETB from Matrix Output
	1533			<5>:3-bit LUT1 <5>/DFF4 Initial Polarity Select 0: Low, 1: High
	1534			<6>:3-bit LUT1 <6>/DFF4 Output Select 0: Q output, 1: QB output
	1535			<7>:3-bit LUT1 <7>/DFF4 or Latch Select 0: DFF function, 1: Latch function

SLG47004

GreenPAK Programmable Mixed-Signal Matrix with In-System Programmability and Advanced Analog Features

Table 69: Register Map (Continued)

Address		Signal Function	Register Bit Definition
Byte	Register Bit		
C0	1536	Rheostat0 data selection	000000000: 0 ~ 111111111:100k
	1537		
	1538		
	1539		
	1540		
	1541		
	1542		
	1543		
C1	1544		
	1545		
	1546	Reserved	
	1547	Reserved	
	1548	Reserved	
	1549	Reserved	
	1550	Reserved	
C2	1551	Reserved	
	1552	Rheostat0 current value (read only)	
	1553		
	1554		
	1555		
	1556		
	1557		
	1558		
1559			
C3	1560		
	1561		
	1562	Reserved	
	1563	Reserved	
	1564	Reserved	
	1565	Reserved	
	1566	Reserved	
C4	1567	Reserved	
	1568	Matrix Input 0	GND
	1569	Matrix Input 1	2-bit LUT0/DFF0 output
	1570	Matrix Input 2	2-bit LUT1/DFF1 output
	1571	Matrix Input 3	2-bit LUT2/DFF2 output
	1572	Matrix Input 4	2-bit LUT3/PGen output
	1573	Matrix Input 5	3-bit LUT0/DFF3 output
	1574	Matrix Input 6	3-bit LUT1/DFF4 output
C5	1575	Matrix Input 7	3-bit LUT2/DFF5 output
	1576	Matrix Input 8	3-bit LUT3/DFF6 output
	1577	Matrix Input 9	3-bit LUT4/DFF7 output
	1578	Matrix Input 10	3-bit LUT5/DFF8 output
	1579	Matrix Input 11	3-bit LUT6/DFF9 output
	1580	Matrix Input 12	CNT_DLY0 output
	1581	Matrix Input 13	MLT0 4-bit LUT1/DFF17_OUT
	1582	Matrix Input 14	CNT_DLY1 output
1583	Matrix Input 15	MLT1 3-bit LUT7/DFF11_OUT	

Table 69: Register Map (Continued)

Address		Signal Function	Register Bit Definition
Byte	Register Bit		
C6	1584	Matrix Input 16	CNT_DLY2 output
	1585	Matrix Input 17	MLT2 3-bit LUT8/DFF12_OUT
	1586	Matrix Input 18	CNT_DLY3 output
	1587	Matrix Input 19	MLT3 3-bit LUT9/DFF13_OUT
	1588	Matrix Input 20	CNT_DLY4 output
	1589	Matrix Input 21	MLT4 3-bit LUT10/DFF14_OUT
	1590	Matrix Input 22	CNT_DLY5 output
	1591	Matrix Input 23	MLT5 3-bit LUT11/DFF15_OUT
C7	1592	Matrix Input 24	CNT_DLY6 output
	1593	Matrix Input 25	MLT6 3-bit LUT12/DFF16_OUT
	1594	Matrix Input 26	3-bit LUT13/Pipe Delay/RippleCNT_out0
	1595	Matrix Input 27	Pipe Delay/RippleCNT_out1
	1596	Matrix Input 28	Pipe Delay/RippleCNT_out2
	1597	Matrix Input 29	4-bit LUT0/DFF10 output
	1598	Matrix Input 30	Programmable Delay Edge Detect Output
	1599	Matrix Input 31	Edge Detect Filter Output
C8	1600	Matrix Input 40	RH0 Idle/Active
	1601	Matrix Input 41	RH1 Idle/Active
	1602	Matrix Input 42	Output of Op Amp0 in ACMP mode
	1603	Matrix Input 43	Output of Op Amp1 in ACMP mode
	1604	Matrix Input 44	IO0 Digital Input
	1605	Matrix Input 45	IO1 Digital Input
	1606	Matrix Input 46	IO2 Digital Input
	1607	Matrix Input 47	IO3 Digital Input
C9	1608	Matrix Input 48	IO4 Digital Input
	1609	Matrix Input 49	IO5 Digital Input
	1610	Matrix Input 50	IO6 Digital Input
	1611	Matrix Input 51	I0 Digital Input
	1612	Matrix Input 52	Oscillator0 output 0
	1613	Matrix Input 53	Oscillator1 output 0
	1614	Matrix Input 54	Oscillator2 output
	1615	Matrix Input 55	Chopper ACMP Out
CA	1616	Matrix Input 56	ACMP0 Output (low speed)
	1617	Matrix Input 57	ACMP1 Output (low speed)
	1618	Matrix Input 58	Oscillator0 output 1
	1619	Matrix Input 59	Oscillator1 output 1
	1620	Matrix Input 60	POR OUT
	1621	Matrix Input 61	V _{DD}
	1622	Matrix Input 62	V _{DD}
	1623	Matrix Input 63	V _{DD}

SLG47004

GreenPAK Programmable Mixed-Signal Matrix with In-System Programmability and Advanced Analog Features

Table 69: Register Map (Continued)

Address		Signal Function	Register Bit Definition
Byte	Register Bit		
CB	1624	CNT0_Q	
	1625		
	1626		
	1627		
	1628		
	1629		
	1630		
	1631		
CC	1632		
	1633		
	1634		
	1635		
	1636		
	1637		
	1638		
	1639		
CD	1640	CNT5_Q	
	1641		
	1642		
	1643		
	1644		
	1645		
	1646		
	1647		
CE	1648	CNT6_Q	
	1649		
	1650		
	1651		
	1652		
	1653		
	1654		
	1655		
CF	1656	Reserved	
	1657	Reserved	
	1658	Reserved	
	1659	Reserved	
	1660	Reserved	
	1661	Reserved	
	1662	Reserved	
	1663	Reserved	

SLG47004

GreenPAK Programmable Mixed-Signal Matrix with In-System Programmability and Advanced Analog Features

Table 69: Register Map (Continued)

Address		Signal Function	Register Bit Definition
Byte	Register Bit		
D0	1664	Rheostat1 data selection	000000000: 0 ~ 111111111:100k
	1665		
	1666		
	1667		
	1668		
	1669		
	1670		
	1671		
D1	1672		
	1673		
	1674	Reserved	
	1675	Reserved	
	1676	Reserved	
	1677	Reserved	
	1678	Reserved	
D2	1679	Reserved	
	1680	Rheostat1 current value (read only)	
	1681		
	1682		
	1683		
	1684		
	1685		
	1686		
1687			
D3	1688		
	1689		
	1690	Reserved	
	1691	Reserved	
	1692	Reserved	
	1693	Reserved	
	1694	Reserved	
D4	1695	Reserved	
	1696	Reserved	
	1697	Reserved	
	1698	Reserved	
	1699	Reserved	
	1700	Reserved	
	1701	Reserved	
D5	1702	Reserved	
	1703	Reserved	
	1704	Reserved	
	1705	Reserved	
	1706	Reserved	
	1707	Reserved	
	1708	Reserved	
	1709	Reserved	
	1710	Reserved	
	1711	Reserved	

SLG47004

GreenPAK Programmable Mixed-Signal Matrix with In-System Programmability and Advanced Analog Features

Table 69: Register Map (Continued)

Address		Signal Function	Register Bit Definition
Byte	Register Bit		
D6	1712	Reserved	
	1713	Reserved	
	1714	Reserved	
	1715	Reserved	
	1716	Reserved	
	1717	Reserved	
	1718	Reserved	
	1719	Reserved	
D7	1720	Reserved	
	1721	Reserved	
	1722	Reserved	
	1723	Reserved	
	1724	Reserved	
	1725	Reserved	
	1726	Reserved	
	1727	Reserved	
D8	1728	Reserved	
	1729	Reserved	
	1730	Reserved	
	1731	Reserved	
	1732	Reserved	
	1733	Reserved	
	1734	Reserved	
	1735	Reserved	
D9	1736	Reserved	
	1737	Reserved	
	1738	Reserved	
	1739	Reserved	
	1740	Reserved	
	1741	Reserved	
	1742	Reserved	
	1743	Reserved	
DA	1744	Reserved	
	1745	Reserved	
	1746	Reserved	
	1747	Reserved	
	1748	Reserved	
	1749	Reserved	
	1750	Reserved	
	1751	Reserved	
DB	1752	Reserved	
	1753	Reserved	
	1754	Reserved	
	1755	Reserved	
	1756	Reserved	
	1757	Reserved	
	1758	Reserved	
	1759	Reserved	

SLG47004

GreenPAK Programmable Mixed-Signal Matrix with In-System Programmability and Advanced Analog Features

Table 69: Register Map (Continued)

Address		Signal Function	Register Bit Definition
Byte	Register Bit		
DC	1760	Reserved	
	1761	Reserved	
	1762	Reserved	
	1763	Reserved	
	1764	Reserved	
	1765	Reserved	
	1766	Reserved	
	1767	Reserved	
DD	1768	ID[24]: Reserved	
	1769	ID[25]: Reserved	Reserved for NVM Power-Up Check Pattern Status (A55A match from Flag)
	1770	ID[27:26]: Reserved for Silicon Identification Service Bits (metal hard code)	
	1771		
	1772	Reserved	
	1773		
	1774		
1775			
1776			
DE	1777	Reserved	
	1778		
	1779		
	1780		
	1781		
	1782		
	1783		
DF	1784	Reserved	
	1785		
	1786		
	1787		
	1788		
	1789		
	1790		
E0	1791		
	1792	RPR<1:0> (2k register read selection bits)	00: 2k register data is unprotected for read 01: 2k register data is partly protected for read 10: 2k register data is fully protected for read 11: reserved
	1793		
	1794	RPR<3:2> (2k register write selection bits)	00: 2k register data is unprotected for write 01: 2k register data is partly protected for write 10: 2k register data is fully protected for write 11: reserved
	1795		
	1796	RH_PRB	0: Rheostat Program Input from matrix enabled 1: Rheostat Program Input from matrix disabled
	1797	Reserved	
	1798	Reserved	
	1799	Reserved	

SLG47004

GreenPAK Programmable Mixed-Signal Matrix with In-System Programmability and Advanced Analog Features

Table 69: Register Map (Continued)

Address		Signal Function	Register Bit Definition	
Byte	Register Bit			
E1	1800	NPR<1:0> (2k NVM configuration selection bits)	00: 2k NVM Configuration data is unprotected for read and write/erase 01: 2k NVM Configuration data is fully protected for read 10: 2k NVM Configuration data is fully protected for write/erase 11: 2k NVM Configuration data is fully protected for read and write/erase	
	1801			
	1802			
	1803	NPR<3:2> (Rheosta0 NVM configuration selection bits)	00: Rheosta0 NVM Configuration data is unprotected for read and write/erase 01: Rheosta0 NVM Configuration data is fully protected for read 10: Rheosta0 NVM Configuration data is fully protected for write/erase 11: Rheosta0 NVM Configuration data is fully protected for read and write/erase	
	1804	NPR<5:4> (Rheosta1 NVM configuration selection bits)	00: Rheosta1 NVM Configuration data is unprotected for read and write/erase 01: Rheosta1 NVM Configuration data is fully protected for read 10: Rheosta1 NVM Configuration data is fully protected for write/erase 11: Rheosta1 NVM Configuration data is fully protected for read and write/erase	
	1805			
	1806	Reserved		
1807	Reserved			
E2	1808	WPR<1:0> (EEPROM Write protect block bits range: page31~16)	00: Upper 1/4 (page16~19) of EEPROM is write protected (default) 01: Upper 2/4 (page16~23) of EEPROM is write protected 10: Upper 3/4 (page16~27) of EEPROM is write protected 11: Entire (page16~31) EEPROM is write protected	
	1809			
	1810	WPRE (EEPROM Write protect register enable)	0: No Software Write Protection enabled (default) 1: Write Protection is set by the state of the WPR<1:0> bits	
	1811	Reserved		
	1812	Reserved		
	1813	Reserved		
	1814	Reserved		
E3	1815	Reserved		
	1816	ERSE<4:0> (Page selection for erase)	Define the page address which will be erased ERSE<4> = 0 corresponds to the upper 2k NVM used for chip configuration ERSE<4> = 1 corresponds to the 2k EEPROM	
	1817			
	1818			
	1819			
	1820	ERSE <2:0> (Erase enable)	000/001/010/011/100/101/111: erase disable 110: cause the NVM erase: full NVM (4k bits) erase for ERSCHIP = 1 if DIS_ERSCHIP=0 or page erase for ERSCHIP=0.	
	1821			
1822				
1823				
E4	1824	PRL (Protection lock)	0: RPR/WPR/NPR setting can be changed 1: RPR/WPR/NPR setting cannot be changed	
	1825	Reserved		
	1826	Reserved		
	1827	Reserved		
	1828	Reserved		
	1829	Reserved		
	1830	Reserved		
1831	Reserved			

SLG47004

GreenPAK Programmable Mixed-Signal Matrix with In-System Programmability and Advanced Analog Features

Table 69: Register Map (Continued)

Address		Signal Function	Register Bit Definition
Byte	Register Bit		
E5	1832	Reserved	
	1833		
	1834		
	1835		
	1836		
	1837		
	1838		
	1839		
E6	1840	Rheostat0 tolerance data <0>	
	1841	Rheostat0 tolerance data <1>	
	1842	Rheostat0 tolerance data <2>	
	1843	Rheostat0 tolerance data <3>	
	1844	Rheostat0 tolerance data <4>	
	1845	Rheostat0 tolerance data <5>	
	1846	Rheostat0 tolerance data <6>	
	1847	Rheostat0 tolerance data <7>	
E7	1848	Rheostat0 tolerance data <8>	
	1849	Rheostat0 tolerance data <9>	
	1850	Rheostat0 tolerance data <10>	
	1851	Rheostat0 tolerance data <11>	
	1852	Rheostat0 tolerance data <12>	
	1853	Rheostat0 tolerance data <13>	
	1854	Rheostat0 tolerance data <14>	
	1855	Sign of Rheostat0 tolerance data	0: "+" 1: "-"
E8	1856	Rheostat1 tolerance data <0>	
	1857	Rheostat1 tolerance data <1>	
	1858	Rheostat1 tolerance data <2>	
	1859	Rheostat1 tolerance data <3>	
	1860	Rheostat1 tolerance data <4>	
	1861	Rheostat1 tolerance data <5>	
	1862	Rheostat1 tolerance data <6>	
	1863	Rheostat1 tolerance data <7>	
E9	1864	Rheostat1 tolerance data <8>	
	1865	Rheostat1 tolerance data <9>	
	1866	Rheostat1 tolerance data <10>	
	1867	Rheostat1 tolerance data <11>	
	1868	Rheostat1 tolerance data <12>	
	1869	Rheostat1 tolerance data <13>	
	1870	Rheostat1 tolerance data <14>	
	1871	Sign of Rheostat1 tolerance data	0: "+"; 1: "-"
EA	1872	Reserved	
	1873		
	1874		
	1875		

SLG47004

GreenPAK Programmable Mixed-Signal Matrix with In-System Programmability and Advanced Analog Features

Table 69: Register Map (Continued)

Address		Signal Function	Register Bit Definition
Byte	Register Bit		
EA	1876	Reserved	
	1877		
	1878		
	1879		
EB	1880	Reserved	
	1881		
	1882		
	1883		
	1884	Reserved	
	1885	Reserved	
	1886	Reserved	
EC	1887	Reserved	
	1888	Reserved	
	1889	Reserved	
	1890	Reserved	
	1891	Reserved	
	1892	Reserved	
	1893	Reserved	
	1894	Reserved	
ED	1895	Reserved	
	1896	Reserved	
	1897	Reserved	
	1898	Reserved	
	1899	Reserved	
	1900	Reserved	
	1901	Reserved	
EE	1902	Reserved	
	1903	Reserved	
	1904	Reserved	
	1905	Reserved	
	1906	Reserved	
	1907	Reserved	
	1908	Reserved	
	1909	Reserved	
EF	1910	Reserved	
	1911	Reserved	
	1912	Reserved	
	1913	Reserved	
	1914	Reserved	
	1915	Reserved	
	1916	Reserved	
	1917	Reserved	
1918	Reserved		
	1919	Reserved	

SLG47004

GreenPAK Programmable Mixed-Signal Matrix with In-System Programmability and Advanced Analog Features

Table 69: Register Map (Continued)

Address		Signal Function	Register Bit Definition
Byte	Register Bit		
F0	1920	Reserved	
	1921		
	1922		
	1923		
	1924		
	1925		
	1926		
	1927		
F1	1928	Reserved	
	1929		
	1930		
	1931		
	1932		
	1933		
	1934		
	1935		
F2	1936	Reserved	
	1937		
	1938		
	1939		
	1940		
	1941		
	1942		
	1943		
F3	1944	Service page lock bit	0: Service page can be changed 1: Service page is locked
	1945	BG Chopper off	0: chopper enable 1: chopper off
	1946	Reserved	
	1947	Reserved	
	1948	BG register power down	0: power on 1: power off
	1949	Reserved	
	1950	Reserved	
F4	1951	Reserved	
	1952	Reserved	
	1953	Reserved	
	1954	Reserved	
	1955	Reserved	
	1956	Reserved	
	1957	Reserved	
	1958	Reserved	
	1959	Reserved	

SLG47004

GreenPAK Programmable Mixed-Signal Matrix with In-System Programmability and Advanced Analog Features

Table 69: Register Map (Continued)

Address		Signal Function	Register Bit Definition
Byte	Register Bit		
F5	1960	Reserved	
	1961	Reserved	
	1962	Reserved	
	1963	Reserved	
	1964	Reserved	
	1965	Reserved	
	1966	Reserved	
	1967	Reserved	
F6	1968	I ² C write mask bits	0: overwrite; 1: mask the bit which set to high
	1969		
	1970		
	1971		
	1972		
	1973		
	1974		
	1975		
F7	1976	Reserved	
	1977		
	1978		
	1979		
	1980		
	1981		
	1982		
	1983		
F8	1984	Reserved	
	1985		
	1986		
	1987		
	1988		
	1989		
	1990		
	1991		
F9	1992	Reserved	
	1993		
	1994		
	1995		
	1996		
	1997		
	1998		
	1999	Reserved	

SLG47004

GreenPAK Programmable Mixed-Signal Matrix with In-System Programmability and Advanced Analog Features

Table 69: Register Map (Continued)

Address		Signal Function	Register Bit Definition
Byte	Register Bit		
FA	2000	Reserved	
	2001		
	2002		
	2003		
	2004		
	2005	Reserved	
	2006	Reserved	
	2007	Reserved	
FB	2008	Reserved	
	2009		
	2010		
	2011		
	2012		
	2013	Reserved	
	2014	Reserved	
	2015	Reserved	
FC	2016	Reserved	
	2017		
	2018		
	2019		
	2020		
	2021	Reserved	
	2022	Reserved	
	2023	Reserved	
FD	2024	Reserved	
	2025		
	2026		
	2027		
	2028		
	2029	Reserved	
	2030	Reserved	
	2031	Reserved	
FE	2032	Reserved	
	2033		
	2034		
	2035		
	2036		
	2037	Reserved	
	2038	Reserved	
	2039	Reserved	

SLG47004

GreenPAK Programmable Mixed-Signal Matrix with In-System Programmability and Advanced Analog Features

Table 69: Register Map (Continued)

Address		Signal Function	Register Bit Definition
Byte	Register Bit		
FF	2040	Reserved	
	2041	Reserved	
	2042	Reserved	
	2043	Reserved	
	2044	Reserved	
	2045	Reserved	
	2046	Reserved	
	2047	Reserved	

SLG47004

GreenPAK Programmable Mixed-Signal Matrix
with In-System Programmability and Advanced Analog Features

22 Package Top Marking System Definition

22.1 STQFN-24L 3 MM X 3 MM X 0.55 MM, 0.4P FCD PACKAGE

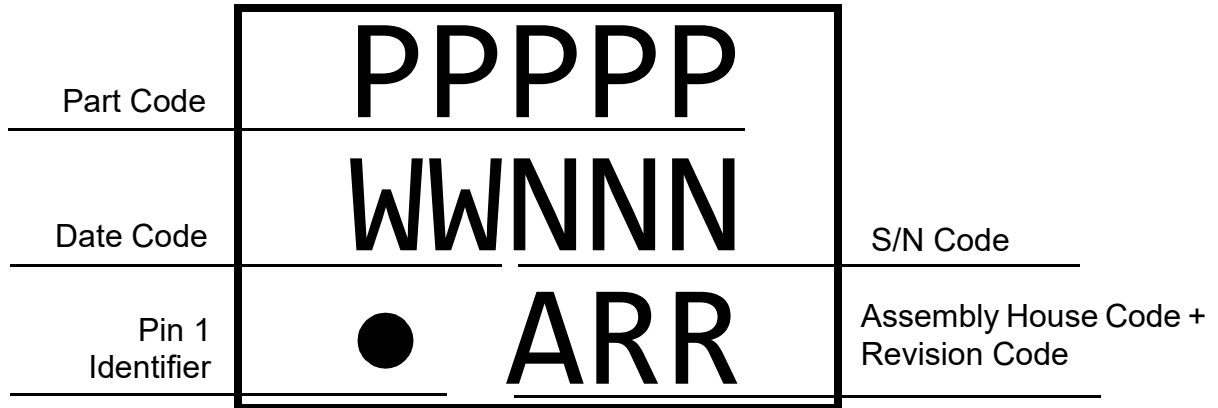

SLG47004

GreenPAK Programmable Mixed-Signal Matrix with In-System Programmability and Advanced Analog Features

23 Package Information

23.1 PACKAGE OUTLINES FOR STQFN 24L 3 MM X 3 MM X 0.55 MM 0.4P GREEN PACKAGE

JEDEC MO-220
IC Net Weight: 0.0116 g

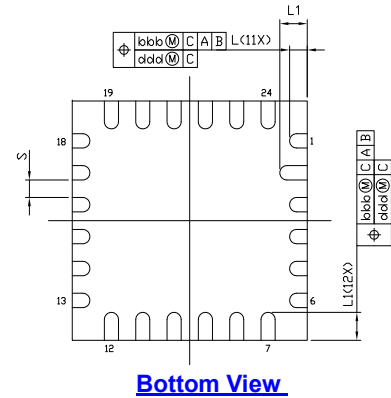
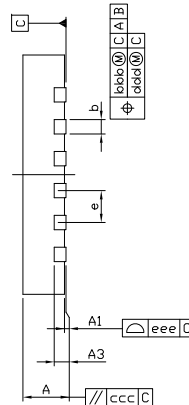
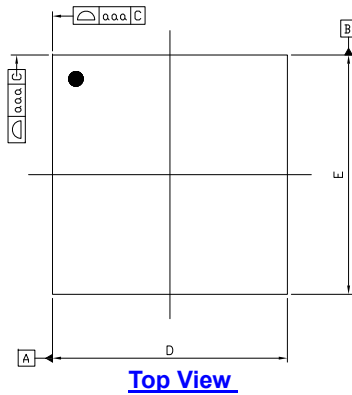

PKG CODE	UQFN					
	MILLIMETER			INCH		
SYMBOLS	MIN.	NOM.	MAX.	MIN.	NOM.	MAX.
A	0.50	0.55	0.60	0.020	0.022	0.024
A1	0.00	0.02	0.05	0.000	0.001	0.002
A3	0.10	0.15	0.20	0.004	0.006	0.008
b	0.13	0.18	0.23	0.005	0.007	0.009
D	2.95	3.00	3.05	0.116	0.118	0.120
E	2.95	3.00	3.05	0.116	0.118	0.120
e	0.40 BSC			0.016 BSC		
L	0.175	0.225	0.275	0.007	0.009	0.011
L1	0.30	0.35	0.40	0.012	0.014	0.016
S	0.22 REF.			0.009 REF.		
aaa	0.07			0.003		
bbb	0.07			0.003		
ccc	0.10			0.004		
ddd	0.05			0.002		
eee	0.08			0.003		

PAD SIZE	LEAD FINISH		JEDEC CODE
	Pure Tin	PPF	
	V	X	N/A

A1 MAX LEAD COPLANARITY 0.05mm
STANDARD TOLERANCE : ±0.05

NOTES :

1. ALL DIMENSIONS ARE IN MILLIMETERS.
2. DIMENSION b APPLIES TO METALLIZED TERMINAL AND IS MEASURED BETWEEN 0.15mm AND 0.30mm FROM THE TERMINAL TIP. IF THE TERMINAL HAS THE OPTIONAL RADIUS ON THE OTHER END OF THE TERMINAL, THE DIMENSION b SHOULD NOT BE MEASURED IN THAT RADIUS AREA.
3. BILATERAL COPLANARITY ZONE APPLIES TO THE EXPOSED HEAT SINK SLUG AS WELL AS THE TERMINALS.

23.2 STQFN HANDLING

Be sure to handle STQFN package only in a clean, ESD-safe environment. Tweezers or vacuum pick-up tools are suitable for handling. Do not handle STQFN package with fingers as this can contaminate the package pins and interface with solder reflow.

23.3 SOLDERING INFORMATION

Please see IPC/JEDEC J-STD-020: for relevant soldering information. More information can be found at www.jedec.org.

SLG47004

GreenPAK Programmable Mixed-Signal Matrix
with In-System Programmability and Advanced Analog Features

24 Ordering Information

Part Number	Type
SLG47004V	24-pin STQFN
SLG47004VTR	24-pin STQFN - Tape and Reel (5k units)

Note 1 Use SLG47004V to order. Shipments are automatically in Tape and Reel.

Note 2 "TR" suffix is no longer used. It is a legacy naming convention shown here only for informational purposes.

24.1 TAPE AND REEL SPECIFICATIONS

Package Type	# of Pins	Nominal Package Size (mm)	Max Units		Reel & Hub Size (mm)	Leader (min)		Trailer (min)		Tape Width (mm)	Part Pitch (mm)
			per Reel	per Box		Pockets	Length (mm)	Pockets	Length (mm)		
STQFN 24L 3 mm x 3 mm 0.4P FC Green	24	3 x 3 x 0.55	5.000	10.000	330 / 100	42	336	42	336	12	8

24.2 CARRIER TAPE DRAWING AND DIMENSIONS

Package Type	Pocket BTM Length (mm)	Pocket BTM Width (mm)	Pocket Depth (mm)	Index Hole Pitch (mm)	Pocket Pitch (mm)	Index Hole Diameter (mm)	Index Hole to Tape Edge (mm)	Index Hole to Pocket Center (mm)	Tape Width (mm)
	A0	B0	K0	P0	P1	D0	E	F	W
STQFN 24L 3 mm x 3 mm 0.4P FC Green	3.3	3.3	0.8	4	8	1.55	1.75	5.5	12

SLG47004

GreenPAK Programmable Mixed-Signal Matrix
with In-System Programmability and Advanced Analog Features

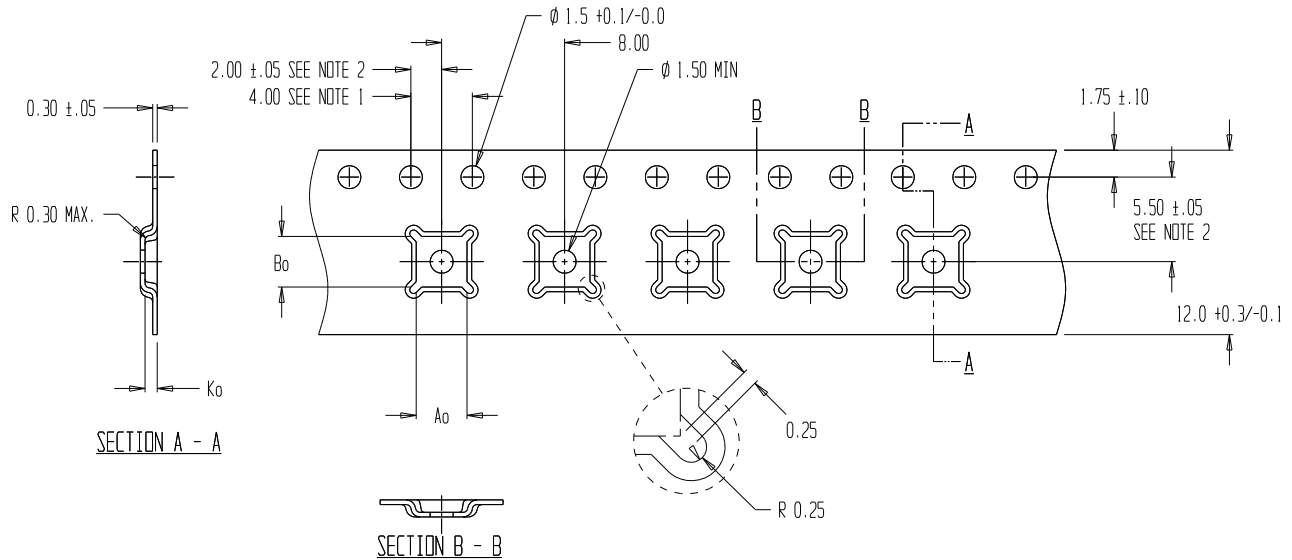

- Notes:
1. 10 SPROCKET HOLE PITCH CUMULATIVE TOLERANCE ±0.2
 2. POCKET POSITION RELATIVE TO SPROCKET HOLE MEASURED AS TRUE POSITION OF POCKET, NOT POCKET HOLE
 3. A0 AND B0 ARE CALCULATED ON A PLANE AT A DISTANCE "R" ABOVE THE BOTTOM OF THE POCKET.

Note: Orientation in carrier: Pin1 is at upper left corner (Quadrant1).

SLG47004

GreenPAK Programmable Mixed-Signal Matrix with In-System Programmability and Advanced Analog Features

25 Layout Guidelines

SLG47004 has two analog supply pins and two ground pins: V_{DD} , V_{DDA} , GND and AGND. Separating analog supply voltage from digital one helps to minimize noise generated by the digital part of IC.

Analog supply voltage domain: operational amplifiers, charge pumps for op amps, charge pumps for Oscillators, bias generators and regulators for op amps, digital rheostats, Chopper ACMP, HD Buffer, Vref of op amp and HD Buffer, Low Power Bandgap.

Digital supply voltage domain: ACMPs, Vref of ACMPs, Vref output buffers, Oscillator 0, Oscillator 1, Oscillator 2, I²C macrocell, NVM logic, Multi-function and Combination Function macrocells.

Analog and digital grounds must be connected together on the PCB board. The place of connection depends on users schematic. For application cases with low digital current of SLG47004, both AGND and GND should be connected to analog ground plane.

It is strongly recommended to connect I0 (Pin21) to the ground if it is not used in the project.

The following suggestions allow to minimize the impact of digital blocks operation on the analog macrocells:

- decrease the slew rate of input digital signals
- use proper grounding. If possible, use grounding polygons along the input/output digital traces
- to interface digital signals first use IO1, IO2, IO3, IO4, then use other GPIOs.

25.1 STQFN 24L 3 MM X 3 MM X 0.55 MM 0.4P GREEN PACKAGE

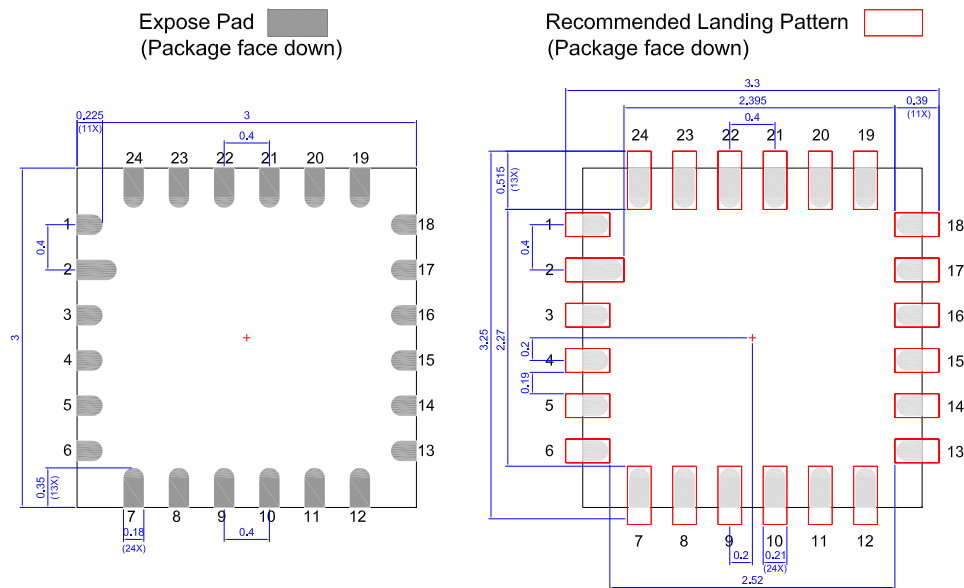

SLG47004

GreenPAK Programmable Mixed-Signal Matrix with In-System Programmability and Advanced Analog Features

Glossary

A

ACK	Acknowledge bit
ACMP	Analog Comparator
ACMPH	Analog Comparator High Speed
ACMPL	Analog Comparator Low Power
AS	Analog Switch

B

BG	Bandgap
----	---------

C

CLK	Clock
CMO	Connection matrix output
CNT	Counter

D

DFF	D Flip-Flop
DI	Digital Input
DILV	Low Voltage Digital Input
DLY	Delay
DNL	Differential Non-Linearity
DR	Digital Rheostat

E

EC	Electrical Characteristics
ERSE	Erase Enable
ERSR	Erase Register
ESD	Electrostatic discharge
EV	End Value

F

FSM	Finite State Machine
-----	----------------------

G

GPI	General Purpose Input
GPIO	General Purpose Input/Output
GPO	General Purpose Output

I

IN	Input
----	-------

SLG47004

GreenPAK Programmable Mixed-Signal Matrix with In-System Programmability and Advanced Analog Features

In Amp	Instrumentation Amplifier
DNL	Differential Non-Linearity
INL	Integral Non-Linearity
IO	Input/Output

L

LPF	Low Pass Filter
LSB	Least Significant Bit
LUT	Look Up Table
LV	Low Voltage

M

MSB	Most Significant Bit
MTP	Multiple-Time-Programmable
MUX	Multiplexer

N

NPR	Non-Volatile Memory Read/Write/Erase Protection
nRST	Reset
NVM	Non-Volatile Memory

O

OA	Operational Amplifier
OD	Open-Drain
OE	Output Enable
Op Amp	Operational Amplifier
OSC	Oscillator
OUT	Output

P

PD	Power-down
PGen	Pattern Generator
POR	Power-On Reset
PP	Push-Pull
PRL	Protect Lock Bit
PT	Programmable Trim
PWR	Power
P DLY	Programmable Delay

R

RPR	Register Read/Write Protection
-----	--------------------------------

SLG47004

GreenPAK Programmable Mixed-Signal Matrix with In-System Programmability and Advanced Analog Features

RPRB	Register Read/Write Protection Bit
RPRL	Register Protection Read/Write/Erase Lock
R/W	Read/Write

S

SCL	I ² C Clock Input
SDA	I ² C Data Input/Output
SLA	Slave Address
SMT	With Schmitt Trigger
SPST	Single-pole/Single throw
SV	nSET Value

T

TS	Temperature Sensor
----	--------------------

V

Vref	Voltage Reference
------	-------------------

W

WOSMT	Without Schmitt Trigger
WPB	Write Protect Bit
WPR	Write Protection Register
WPRE	Write Protect Enable
WS	Wake and Sleep Controller

SLG47004

GreenPAK Programmable Mixed-Signal Matrix with In-System Programmability and Advanced Analog Features

Revision History

Revision	Date	Description
3.9	19-Nov-2024	Corrected LUTs naming Corrected Programmable Trim Blocks and Digital Rheostat's Internal Circuit Corrected I ² C General Timing Characteristics figure Corrected I ² C Pins Timing Characteristics Replaced graph OA1 Open Loop Gain and Phase vs. Frequency for BW = 8 MHz
3.8	10-Oct-2024	Corrected Input Voltage Noise value in table EC of OA
3.7	1-Jul-2024	Updated subsection Changing Rheostat Value Directly via I ² C Fixed typos
3.6	6-Feb-2024	Updated registers [1007:1000] Updated figure Typical Implementation of Voltage Regulator (A) and Current Sources (B, C) Fixed typos
3.5	27-Sep-2023	Added Note 3 to section Wake and Sleep Controller Updated table Erase Register Bit Function Description Updated TS equations Fixed typos
3.4	3-Apr-2023	Updated R _{PULL} in section Electrical Characteristics Corrected Figure Reset Command Timing
3.3	1-Mar-2023	Added notes to section Ordering Information
3.2	23-Jan-2023	Corrected BWDT _{CAP} parameter in table 100K Digital Rheostat Characteristics
3.1	21-Sept-2022	Updated parameter V _{OFFSET} in table Programmable Operational Amplifier Characteristics
3.0	8-Sept-2022	Final version

SLG47004

GreenPAK Programmable Mixed-Signal Matrix with In-System Programmability and Advanced Analog Features

Status Definitions

Revision	Datasheet Status	Product Status	Definition
1.<n>	Target	Development	This datasheet contains the design specifications for product development. Specifications may change in any manner without notice.
2.<n>	Preliminary	Qualification	This datasheet contains the specifications and preliminary characterization data for products in pre-production. Specifications may be changed at any time without notice in order to improve the design.
3.<n>	Final	Production	This datasheet contains the final specifications for products in volume production. The specifications may be changed at any time in order to improve the design, manufacturing and supply. Major specification changes are communicated via Customer Product Notifications. Datasheet changes are communicated via www.renesas.com .
4.<n>	Obsolete	Archived	This datasheet contains the specifications for discontinued products. The information is provided for reference only.

RoHS Compliance

Renesas Electronics Corporation's suppliers certify that its products are in compliance with the requirements of Directive 2011/65/EU of the European Parliament on the restriction of the use of certain hazardous substances in electrical and electronic equipment. RoHS certificates from our suppliers are available on request.

IMPORTANT NOTICE AND DISCLAIMER

RENESAS ELECTRONICS CORPORATION AND ITS SUBSIDIARIES (“RENESAS”) PROVIDES TECHNICAL SPECIFICATIONS AND RELIABILITY DATA (INCLUDING DATASHEETS), DESIGN RESOURCES (INCLUDING REFERENCE DESIGNS), APPLICATION OR OTHER DESIGN ADVICE, WEB TOOLS, SAFETY INFORMATION, AND OTHER RESOURCES “AS IS” AND WITH ALL FAULTS, AND DISCLAIMS ALL WARRANTIES, EXPRESS OR IMPLIED, INCLUDING, WITHOUT LIMITATION, ANY IMPLIED WARRANTIES OF MERCHANTABILITY, FITNESS FOR A PARTICULAR PURPOSE, OR NON-INFRINGEMENT OF THIRD-PARTY INTELLECTUAL PROPERTY RIGHTS.

These resources are intended for developers who are designing with Renesas products. You are solely responsible for (1) selecting the appropriate products for your application, (2) designing, validating, and testing your application, and (3) ensuring your application meets applicable standards, and any other safety, security, or other requirements. These resources are subject to change without notice. Renesas grants you permission to use these resources only to develop an application that uses Renesas products. Other reproduction or use of these resources is strictly prohibited. No license is granted to any other Renesas intellectual property or to any third-party intellectual property. Renesas disclaims responsibility for, and you will fully indemnify Renesas and its representatives against, any claims, damages, costs, losses, or liabilities arising from your use of these resources. Renesas' products are provided only subject to Renesas' Terms and Conditions of Sale or other applicable terms agreed to in writing. No use of any Renesas resources expands or otherwise alters any applicable warranties or warranty disclaimers for these products.

(Disclaimer Rev.1.01)

Corporate Headquarters

TOYOSU FORESIA, 3-2-24 Toyosu,
Koto-ku, Tokyo 135-0061, Japan
www.renesas.com

Trademarks

Renesas and the Renesas logo are trademarks of Renesas Electronics Corporation. All trademarks and registered trademarks are the property of their respective owners.

Contact Information

For further information on a product, technology, the most up-to-date version of a document, or your nearest sales office, please visit www.renesas.com/contact-us/.