

SLG59M1558V

An Ultra-small 1.0 mm², 28.5 mΩ, 1.0 A, Load Switch

General Description

The SLG59M1558V is designed for load switching applications with ultra low quiescent current. The part comes with one 28.5 mΩ, 1.0 A rated P-channel MOSFET controlled by a single ON control pin. The product is packaged in an ultra-small 1.0 mm x 1.0 mm package.

Features

- One 1.0 A MOSFET
- Ultra Low Quiescent Current
- Low RDS_{ON}
 - 28.5 mΩ at V_{IN} = 5.0 V
 - 36.4 mΩ at V_{IN} = 3.3 V
 - 44.3 mΩ at V_{IN} = 2.5 V
 - 60.8 mΩ at V_{IN} = 1.8 V
 - 77.6 mΩ at V_{IN} = 1.5 V
- V_{IN} = 1.5 V to 5.5 V
- Pb-Free / Halogen-Free / RoHS compliant
- STDFN 4L, 1.0 x 1.0 x 0.55 mm

Pin Configuration

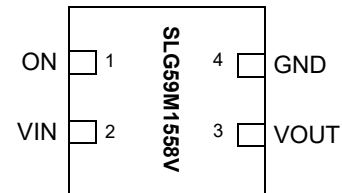

4-pin STDFN
(Top View)

Applications

- Notebook Power Rail Switching
- Tablet Power Rail Switching
- Smartphone Power Rail Switching

Block Diagram

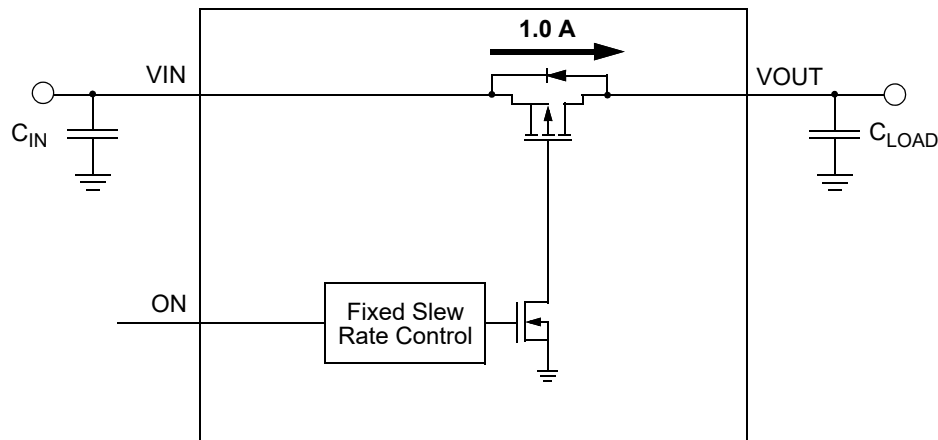

SLG59M1558V

An Ultra-small 1.0 mm², 28.5 mΩ, 1.0 A, Load Switch

Pin Description

Pin #	Pin Name	Type	Pin Description
1	ON	Input	A low-to-high transition on this pin initiates the operation of the SLG59M1558V. ON is an asserted HIGH, level-sensitive CMOS input with ON_V _{IL} < 0.3 V and ON_V _{IH} > 0.85 V. As the ON pin input circuit does not have an internal pull-down resistor, connect this pin to a general-purpose output (GPO) of a microcontroller, an application processor, or a system controller – do not allow this pin to be open-circuited.
2	VIN	MOSFET	Input terminal connection of the power MOSFET. Connect a 10 μF (or larger) low-ESR capacitor from this pin to ground. Capacitors used at VIN should be rated at 10 V or higher.
3	VOUT	MOSFET	Output terminal connection of the power MOSFET. Capacitors used at VOUT should be rated at 10 V or higher.
4	GND	GND	Ground connection. Connect this pin to system analog or power ground plane.

Ordering Information

Part Number	Type	Production Flow
SLG59M1558V	STDFN 4L	Industrial, -40 °C to 85 °C
SLG59M1558VTR	STDFN 4L (Tape and Reel)	Industrial, -40 °C to 85 °C

SLG59M1558V

An Ultra-small 1.0 mm², 28.5 mΩ, 1.0 A, Load Switch

Absolute Maximum Ratings

Parameter	Description	Conditions	Min.	Typ.	Max.	Unit
V _{IN}	Load Switch Input Voltage		--	--	6	V
T _S	Storage Temperature		-65	--	140	°C
T _J	Junction Temperature		-40	--	150	°C
ESD _{HBM}	ESD Protection	Human Body Model	2000	--	--	V
MSL	Moisture Sensitivity Level		1			
θ _{JA}	Thermal Resistance	1.0 x 1.0 mm, 4L STDFN; Determined using 1 in ² , 2 oz. copper pads under each VIN and VOUT terminals and FR4 pcb material	--	122	--	°C/W
W _{DIS}	Package Power Dissipation		--	--	0.5	W
MOSFET I _{DSPEAK}	Peak Current from VIN to VOUT	For no more than 1 ms with 1% duty cycle	--	--	1.5	A

Note: Stresses greater than those listed under "Absolute Maximum Ratings" may cause permanent damage to the device. This is a stress rating only and functional operation of the device at these or any other conditions above those indicated in the operational sections of this specification is not implied. Exposure to absolute maximum rating conditions for extended periods may affect reliability.

Electrical Characteristics

T_A = -40 °C to 85 °C unless otherwise noted. Typical values are at T_A = 25 °C

Parameter	Description	Conditions	Min.	Typ.	Max.	Unit
V _{IN}	Load Switch Input Voltage	-40 °C to 85 °C	1.5	--	5.5	V
I _{IN}	Load Switch Input Current (PIN 2)	when OFF, V _{IN} = 5.5 V, No load	--	0.02	1	μA
		when ON, ON = V _{IN} , No load	--	0.05	0.5	μA
I _{FET_OFF}	MOSFET OFF Leakage Current	ON = LOW; V _{IN} = 5.5 V	--	0.05	1	μA
I _{ON_LKG}	ON Pin Input Leakage		--	--	0.1	μA
RDS _{ON}	ON Resistance, T _A = 25 °C	V _{IN} = 5.5 V, I _{DS} = 100 mA	--	28.5	32.0	mΩ
		V _{IN} = 3.3 V, I _{DS} = 100 mA	--	36.4	40.0	mΩ
		V _{IN} = 2.5 V, I _{DS} = 100 mA	--	44.3	49.0	mΩ
		V _{IN} = 1.8 V, I _{DS} = 100 mA	--	60.8	65.0	mΩ
		V _{IN} = 1.5 V, I _{DS} = 100 mA	--	77.6	82.0	mΩ
RDS _{ON}	ON Resistance, T _A = 85 °C	V _{IN} = 5.5 V, I _{DS} = 100 mA	--	34.0	36.0	mΩ
		V _{IN} = 3.3 V, I _{DS} = 100 mA	--	43.8	46.0	mΩ
		V _{IN} = 2.5 V, I _{DS} = 100 mA	--	53.3	56.0	mΩ
		V _{IN} = 1.8 V, I _{DS} = 100 mA	--	72.2	76.0	mΩ
		V _{IN} = 1.5 V, I _{DS} = 100 mA	--	90.7	94.0	mΩ
MOSFET I _{DS}	Current from VIN to VOUT	Continuous	--	--	1.0	A

SLG59M1558V

An Ultra-small 1.0 mm², 28.5 mΩ, 1.0 A, Load Switch

Electrical Characteristics (continued)

T_A = -40 °C to 85 °C unless otherwise noted. Typical values are at T_A = 25 °C

Parameter	Description	Conditions	Min.	Typ.	Max.	Unit
T _{ON_Delay}	ON Delay Time	50% ON to V _{OUT} Ramp Start; V _{IN} = 5 V, C _{LOAD} = 0.1 μF, R _{LOAD} = 10 Ω	10	15	27	μs
		50% ON to V _{OUT} Ramp Start; V _{IN} = 3.3 V, C _{LOAD} = 0.1 μF, R _{LOAD} = 10 Ω	17	31	40	μs
		50% ON to V _{OUT} Ramp Start; V _{IN} = 1.5 V, C _{LOAD} = 0.1 μF, R _{LOAD} = 10 Ω	44	69	96	μs
T _{Total_ON}	Total Turn ON Time	50% ON to 90% V _{OUT} ; V _{IN} = 5.0 V, C _{LOAD} = 0.1 μF, R _{LOAD} = 10 Ω	114	122	134	μs
		50% ON to 90% V _{OUT} ; V _{IN} = 3.3 V, C _{LOAD} = 0.1 μF, R _{LOAD} = 10 Ω	146	156	176	μs
		50% ON to 90% V _{OUT} ; V _{IN} = 1.5 V, C _{LOAD} = 0.1 μF, R _{LOAD} = 10 Ω	292	332	399	μs
T _{VOUT(R)}	V _{OUT} Rise Time	10% V _{OUT} to 90% V _{OUT} ; V _{IN} = 5.0 V, C _{LOAD} = 0.1 μF, R _{LOAD} = 10 Ω	92	97	107	μs
		10% V _{OUT} to 90% V _{OUT} ; V _{IN} = 3.3 V, C _{LOAD} = 0.1 μF, R _{LOAD} = 10 Ω	116	120	131	μs
		10% V _{OUT} to 90% V _{OUT} ; V _{IN} = 1.5 V, C _{LOAD} = 0.1 μF, R _{LOAD} = 10 Ω	228	253	296	μs
ON_V _{IH}	High Input Voltage on ON pin		0.85	--	V _{IN}	V
ON_V _{IL}	Low Input Voltage on ON pin		-0.3	0	0.3	V
T _{OFF_Delay}	OFF Delay Time	50% ON to V _{OUT} Fall Start, V _{IN} = 5 V, R _{LOAD} = 10 Ω, no C _{LOAD}	6.2	6.5	7.0	μs

SLG59M1558V

An Ultra-small 1.0 mm², 28.5 mΩ, 1.0 A, Load Switch

V_{IN} vs. Max I_{DS}, Safe Operation Area

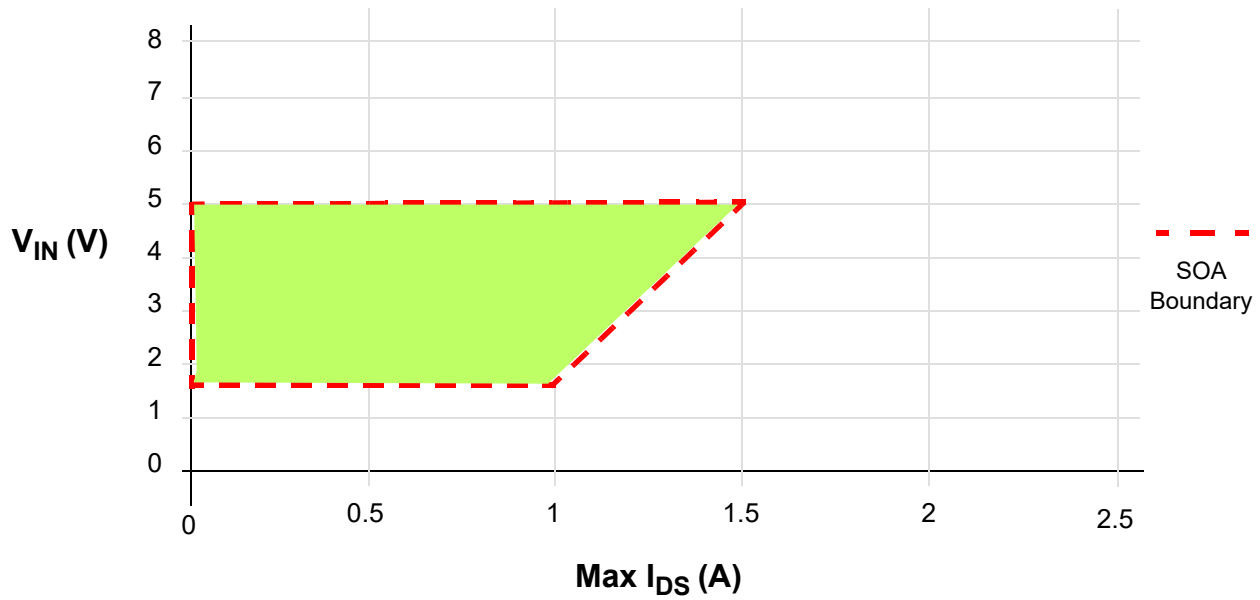

T_{Total_ON}, T_{ON_Delay} and Rise Time Measurement

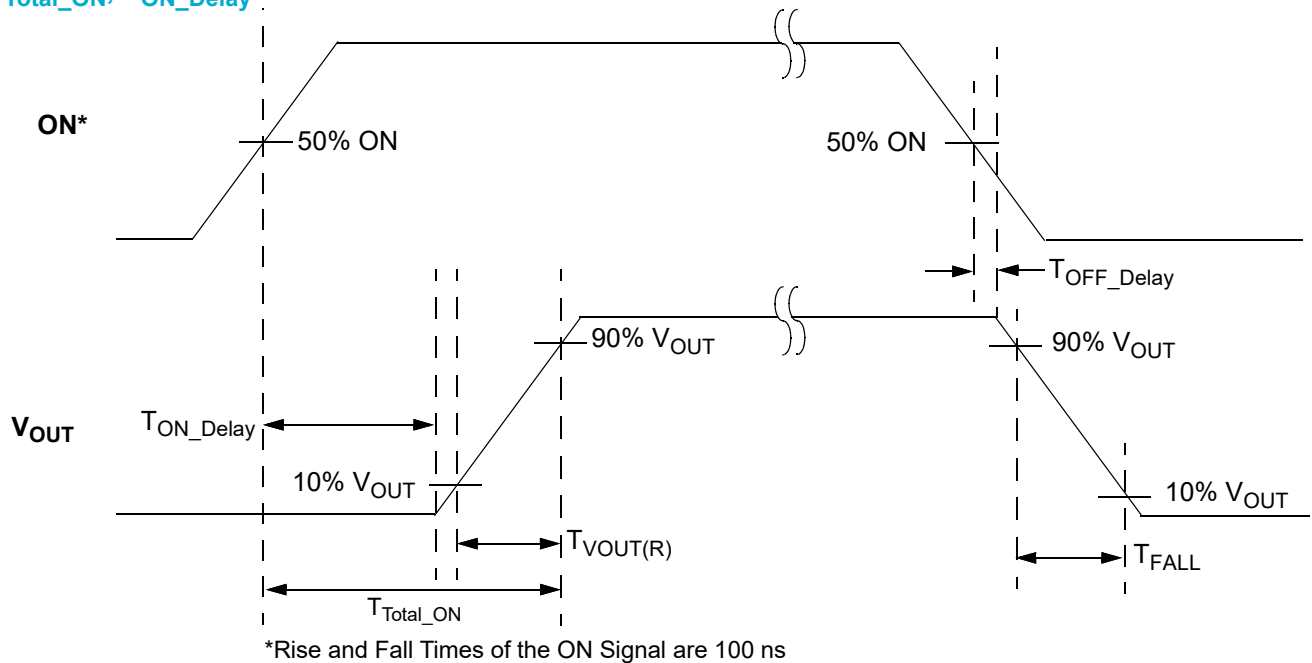

SLG59M1558V

An Ultra-small 1.0 mm², 28.5 mΩ, 1.0 A, Load Switch

SLG59M1558V Power-Up/Power-Down Sequence Considerations

A nominal power-up sequence is to apply V_{IN} and toggle the ON pin LOW-to-HIGH after V_{IN} is at least 90% of its final value. A nominal power-down sequence is the power-up sequence in reverse order. If V_{IN} ramp is too fast, a voltage glitch may appear on the output pin at VOUT. To prevent glitches at the output, it is recommended to connect at least 0.1uF capacitor from the VOUT pin to GND and to keep the V_{IN} ramp time higher than 2 ms.

Power Dissipation Considerations

The junction temperature of the SLG59M1558V depends on factors such as board layout, ambient temperature, external air flow over the package, load current, and the $R_{DS_{ON}}$ generated voltage drop across each power MOSFET. While the primary contributor to the increase in the junction temperature of the SLG59M1558V is the power dissipation of its power MOSFETs, its power dissipation and the junction temperature in nominal operating mode can be calculated using the following equations:

$$PD_{TOTAL} = R_{DS_{ON}} \times I_{DS}^2$$

where:

PD_{TOTAL} = Total package power dissipation, in Watts (W)

$R_{DS_{ON}}$ = Power MOSFET ON resistance, in Ohms (Ω)

I_{DS} = Output current, in Amps (A)

and

$$T_J = PD_{TOTAL} \times \theta_{JA} + T_A$$

where:

T_J = Die junction temperature, in Celsius degrees ($^{\circ}C$)

θ_{JA} = Package thermal resistance, in Celsius degrees per Watt ($^{\circ}C/W$) – highly dependent on pcb layout

T_A = Ambient temperature, in Celsius degrees ($^{\circ}C$)

In nominal operating mode, the SLG59M1558V's power dissipation can also be calculated by taking into account the voltage drop across the load switch ($V_{IN} - V_{OUT}$) and the magnitude of the switch's output current (I_{DS}):

$$PD_{TOTAL} = (V_{IN} - V_{OUT}) \times I_{DS} \text{ or}$$

$$PD_{TOTAL} = (V_{IN} - (R_{LOAD} \times I_{DS})) \times I_{DS}$$

where:

PD_{TOTAL} = Total package power dissipation, in Watts (W)

V_{IN} = Switch input Voltage, in Volts (V)

R_{LOAD} = Output Load Resistance, in Ohms (Ω)

I_{DS} = Switch output current, in Amps (A)

V_{OUT} = Switch output voltage, or $R_{LOAD} \times I_{DS}$

SLG59M1558V

An Ultra-small 1.0 mm², 28.5 mΩ, 1.0 A, Load Switch

SLG59M1558V Layout Suggestion

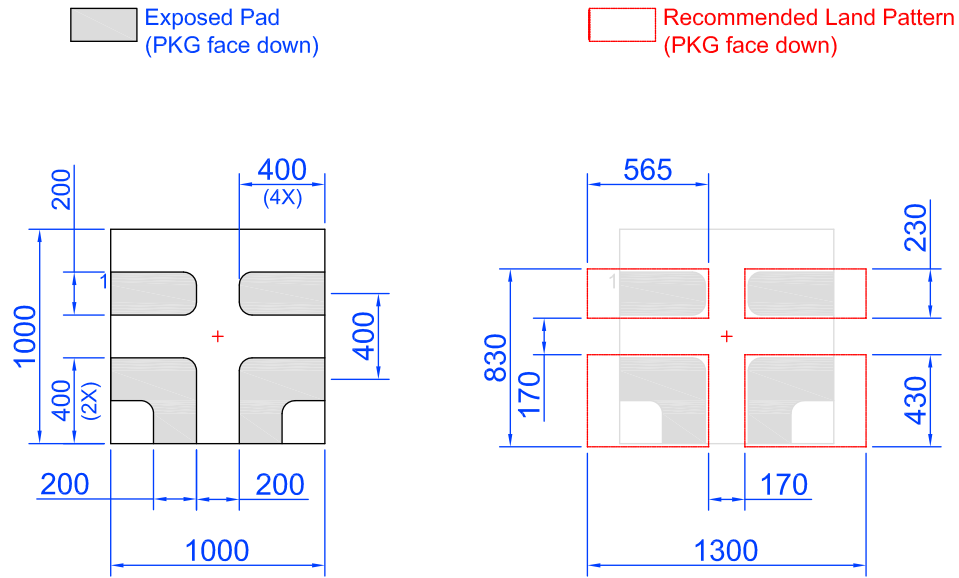

Note: All dimensions shown in micrometers (μm)

SLG59M1558V

An Ultra-small 1.0 mm², 28.5 mΩ, 1.0 A, Load Switch

Layout Guidelines:

1. Since the VIN and VOUT pins dissipate most of the heat generated during high-load current operation, it is highly recommended to make power traces as short, direct, and wide as possible. A good practice is to make power traces with an absolute minimum widths of 15 mils (0.381 mm) per Ampere. A representative layout, shown in [Figure 1](#) illustrates proper techniques for heat to transfer as efficiently as possible out of the device;
2. To minimize the effects of parasitic trace inductance on normal operation, it is recommended to connect input C_{IN} and output C_{LOAD} low-ESR capacitors as close as possible to the SLG59M1558V's VIN and VOUT pins;
3. The GND pin should be connected to system analog or power ground plane.
4. 2 oz. copper is recommended for high current operation.

SLG59M1558V Evaluation Board:

A GreenFET Evaluation Board for SLG59M1558V is designed according to the statements above and is illustrated on [Figure 1](#). Please note that evaluation board has D_Sense and S_Sense pads. They cannot carry high currents and dedicated only for RDS_{ON} evaluation.

Please solder your SLG59M1558V here

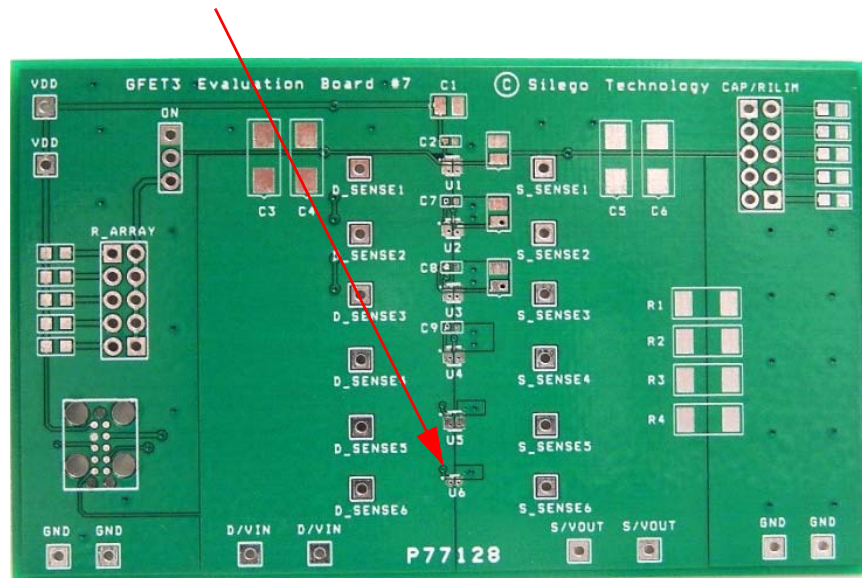

Figure 1. SLG59M1558V Evaluation Board

SLG59M1558V

An Ultra-small 1.0 mm², 28.5 mΩ, 1.0 A, Load Switch

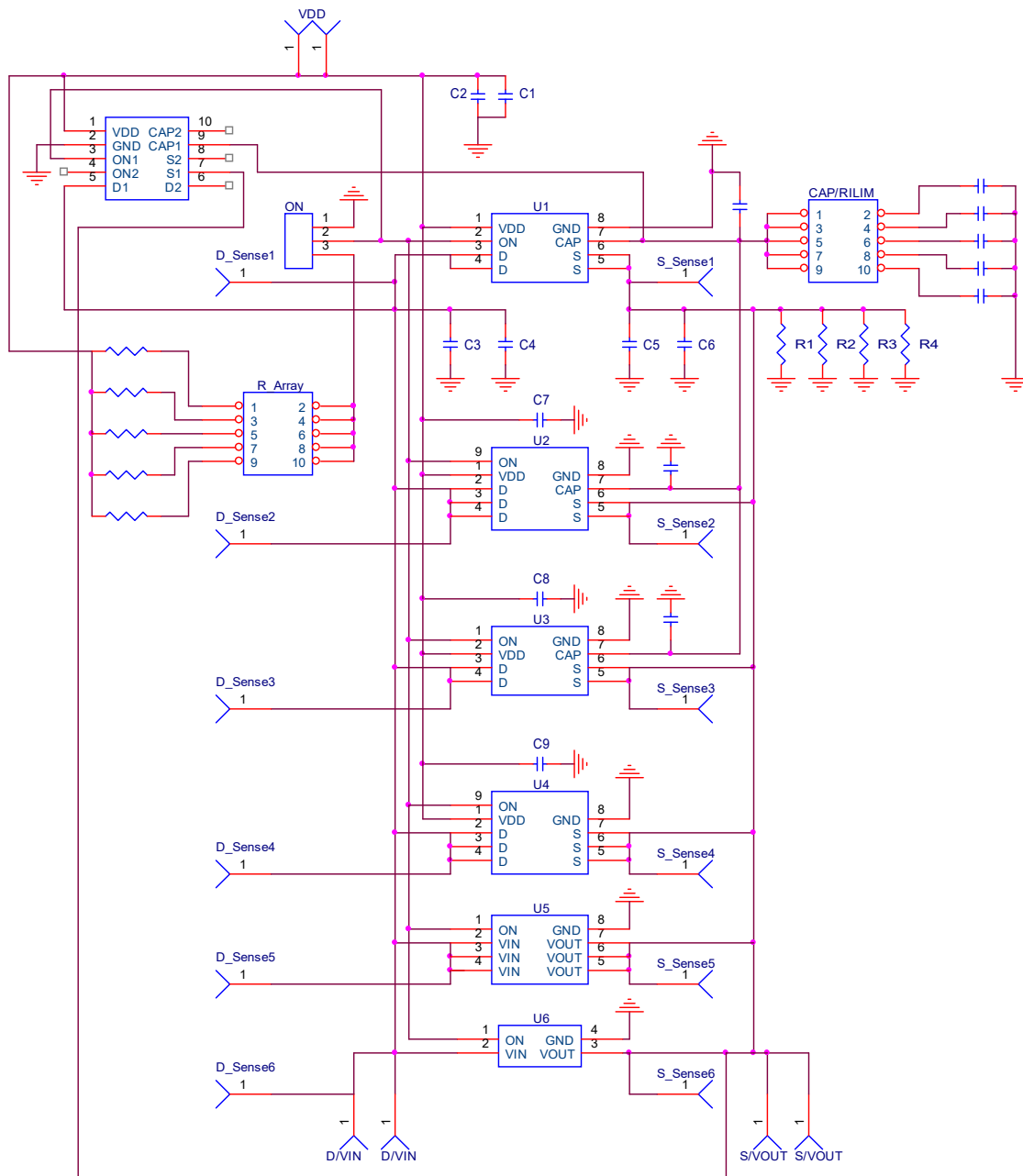

Figure 2. SLG59M1558V Evaluation Board Connection Circuit

SLG59M1558V

An Ultra-small 1.0 mm², 28.5 mΩ, 1.0 A, Load Switch

Basic Test Setup and Connections

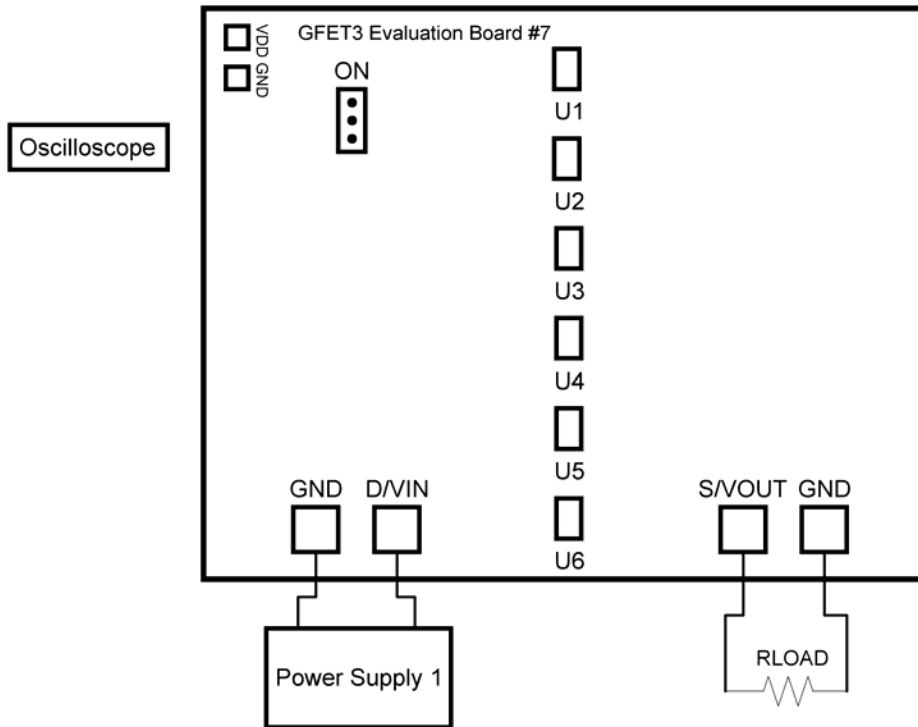

Figure 3. SLG59M1558V Evaluation Board Connection Circuit

EVB Configuration

1. Connect oscilloscope probes to D/VIN, S/VOUT, ON, etc.;
2. Turn on Power Supply 1 and set desired V_{IN} from 1.5 V...5.5 V range;
3. Toggle the ON signal High or Low to observe SLG59M1558V operation.

SLG59M1558V

An Ultra-small 1.0 mm², 28.5 mΩ, 1.0 A, Load Switch

Package Top Marking System Definition

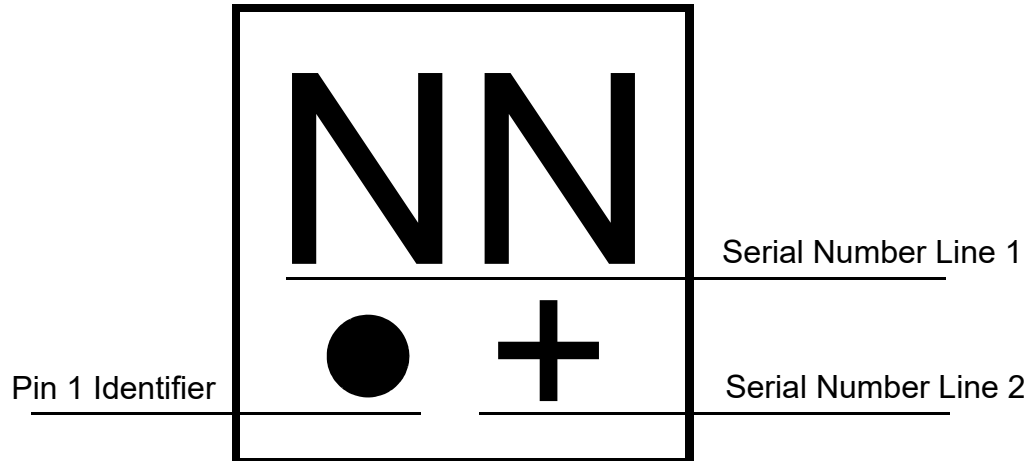

NN -Part Serial Number Field Line 1
 where each “N” character can be A-Z and 0-9
 + - Part Serial Number Field Line 2
 where “+” character can be +, -, =, or blank

SLG59M1558V

An Ultra-small 1.0 mm², 28.5 mΩ, 1.0 A, Load Switch

Package Drawing and Dimensions

4 Lead STDFN Package 1.0 x 1.0 mm

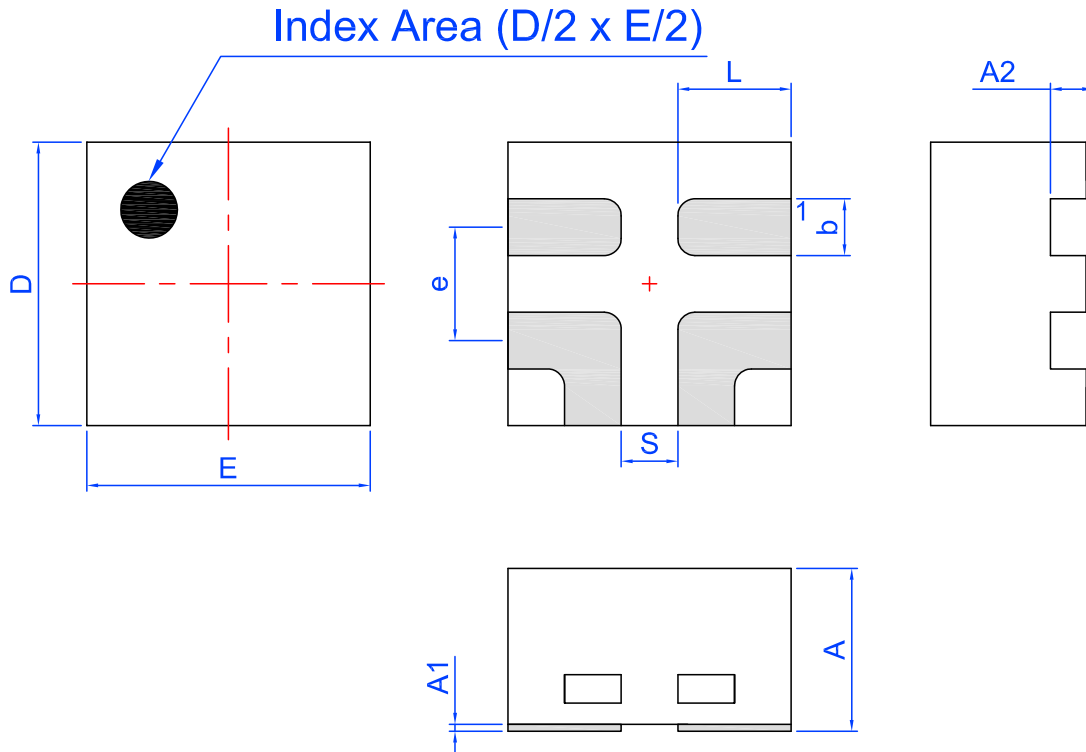

Unit: mm

Symbol	Min	Nom.	Max	Symbol	Min	Nom.	Max
A	0.50	0.55	0.60	D	0.95	1.00	1.05
A1	0.005	-	0.060	E	0.95	1.00	1.05
A2	0.10	0.15	0.20	L	0.35	0.40	0.45
b	0.15	0.20	0.25	S	0.2 REF		
e	0.40 BSC						

SLG59M1558V

An Ultra-small 1.0 mm², 28.5 mΩ, 1.0 A, Load Switch

Tape and Reel Specifications

Package Type	# of Pins	Nominal Package Size [mm]	Max Units		Reel & Hub Size [mm]	Leader (min)		Trailer (min)		Tape Width [mm]	Part Pitch [mm]
			per Reel	per Box		Pockets	Length [mm]	Pockets	Length [mm]		
STDFN 4L Green	4	1.0 x 1.0 x 0.55	8000	8000	178 / 60	200	400	200	400	8	2

Carrier Tape Drawing and Dimensions

Package Type	Pocket BTM Length	Pocket BTM Width	Pocket Depth	Index Hole Pitch	Pocket Pitch	Index Hole Diameter	Index Hole to Tape Edge	Index Hole to Pocket Center	Tape Width
	A0	B0	K0	P0	P1	D0	E	F	W
STDFN 4L Green	1.16	1.16	0.63	4	2	1.5	1.75	3.5	8

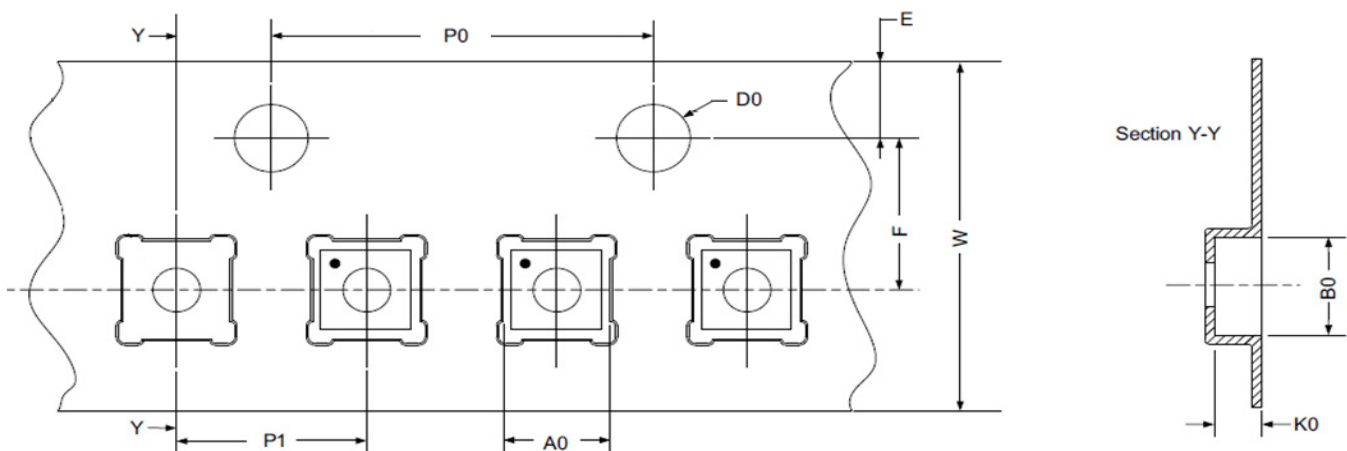

Refer to EIA-481 specification

Recommended Reflow Soldering Profile

Please see IPC/JEDEC J-STD-020: latest revision for reflow profile based on package volume of 0.55 mm³ (nominal). More information can be found at www.jedec.org.

SLG59M1558V

An Ultra-small 1.0 mm², 28.5 mΩ, 1.0 A, Load Switch

Revision History

Date	Version	Change
8/7/2023	1.08	Fixed typo in Title
2/2/2022	1.07	Updated Company name and logo Fixed typos
10/27/2020	1.06	Added MSL to Abs Max Table
6/10/2020	1.05	Updated Style and formatting Added Power Dissipation Considerations Added Layout Guidelines Fixed typos
11/14/2017	1.04	Updated Package Marking Definition
11/30/2016	1.03	Fixed Parameter name from VDD to VIN in Abs. Max Table
6/22/2016	1.02	Added section on Power Up/Down Sequence Considerations Removed IDS_ikg parameter (same as IDD when OFF) Updated Recommended Layout suggestion
9/11/2015	1.01	Updated IDD and Tdelay_ON

IMPORTANT NOTICE AND DISCLAIMER

RENESAS ELECTRONICS CORPORATION AND ITS SUBSIDIARIES (“RENESAS”) PROVIDES TECHNICAL SPECIFICATIONS AND RELIABILITY DATA (INCLUDING DATASHEETS), DESIGN RESOURCES (INCLUDING REFERENCE DESIGNS), APPLICATION OR OTHER DESIGN ADVICE, WEB TOOLS, SAFETY INFORMATION, AND OTHER RESOURCES “AS IS” AND WITH ALL FAULTS, AND DISCLAIMS ALL WARRANTIES, EXPRESS OR IMPLIED, INCLUDING, WITHOUT LIMITATION, ANY IMPLIED WARRANTIES OF MERCHANTABILITY, FITNESS FOR A PARTICULAR PURPOSE, OR NON-INFRINGEMENT OF THIRD-PARTY INTELLECTUAL PROPERTY RIGHTS.

These resources are intended for developers who are designing with Renesas products. You are solely responsible for (1) selecting the appropriate products for your application, (2) designing, validating, and testing your application, and (3) ensuring your application meets applicable standards, and any other safety, security, or other requirements. These resources are subject to change without notice. Renesas grants you permission to use these resources only to develop an application that uses Renesas products. Other reproduction or use of these resources is strictly prohibited. No license is granted to any other Renesas intellectual property or to any third-party intellectual property. Renesas disclaims responsibility for, and you will fully indemnify Renesas and its representatives against, any claims, damages, costs, losses, or liabilities arising from your use of these resources. Renesas' products are provided only subject to Renesas' Terms and Conditions of Sale or other applicable terms agreed to in writing. No use of any Renesas resources expands or otherwise alters any applicable warranties or warranty disclaimers for these products.

(Disclaimer Rev.1.01 Jan 2024)

Corporate Headquarters

TOYOSU FORESIA, 3-2-24 Toyosu,
Koto-ku, Tokyo 135-0061, Japan
www.renesas.com

Trademarks

Renesas and the Renesas logo are trademarks of Renesas Electronics Corporation. All trademarks and registered trademarks are the property of their respective owners.

Contact Information

For further information on a product, technology, the most up-to-date version of a document, or your nearest sales office, please visit www.renesas.com/contact-us/.