

SLG59M1649V

An Ultra-small, Low-power 23 mΩ, 4 A, P-Channel Load Switch with Reverse-Current Blocking

General Description

The SLG59M1649V is a self-powered, high-performance, 23 mΩ pFET load switch designed for 1.5 V to 5.5 V power rail applications up to 4 A. When enabled, internal reverse-current protection will quickly open the switch in the event of a reverse-voltage condition is detected

(a $V_{OUT} + 50 \text{ mV} > V_{IN}$ condition opens the switch). Upon the detection of a reverse condition, an open-drain $\overline{\text{FAULT}}$ output is asserted. In the event the V_{IN} voltage is too low, the load switch also contains an internal $V_{IN(UVLO)}$ threshold monitor to keep or to turn the switch OFF.

Designed to operate over a -40°C to 85°C range, the SLG59M1649V is available in a RoHS-compliant, ultra-small 1.0 x 1.6 mm STDFN package.

Pin Configuration

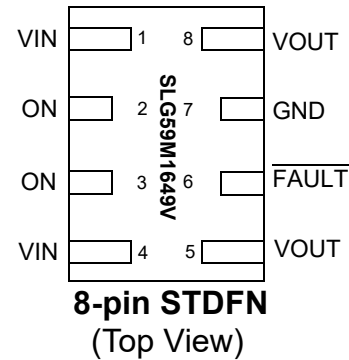

Features

- Steady-state Operating Current: Up to 4 A
- Low Typical $R_{DS(ON)}$:
 - 23 mΩ at $V_{IN} = 5 \text{ V}$
 - 31 mΩ at $V_{IN} = 2.5 \text{ V}$
 - 42 mΩ at $V_{IN} = 1.5 \text{ V}$
- Operating Voltage: 1.5 V to 5.5 V
- Reverse-voltage Detection when ON or OFF
- Internal Gate Driver and V_{OUT} Discharge
- Open-drain $\overline{\text{FAULT}}$ Signaling
- Operating temperature range: -40°C to 85°C
- Low θ_{JA} , 8-pin 1.0 mm x 1.6 mm STDFN Packaging
 - Pb-Free / Halogen-Free / RoHS compliant packaging

Applications

- Power-Rail Switching:
 - Notebook/Laptop/Tablet PCs
 - Smartphones/Wireless Handsets
 - High-definition Digital Cameras
 - Set-top Boxes
- Point of Sales Pins
- GPS Navigation Devices

Block Diagram

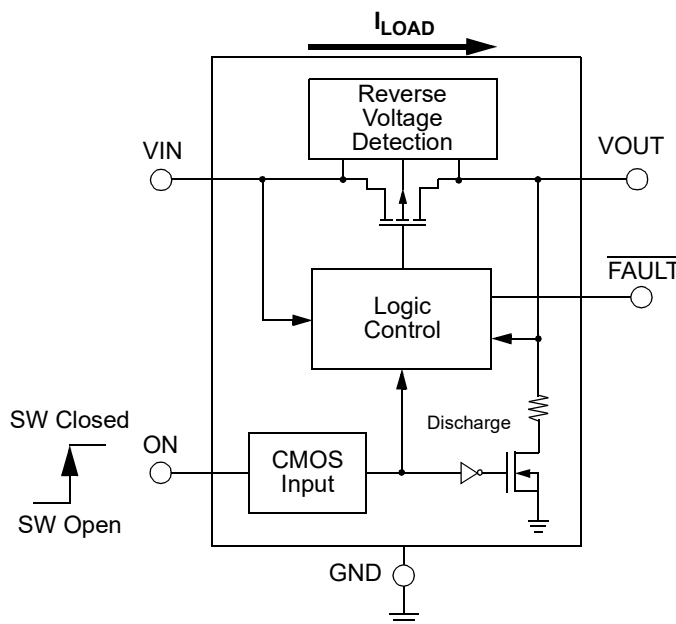

SLG59M1649V

An Ultra-small, Low-power 23 mΩ, 4 A,
P-Channel Load Switch with Reverse-Current Blocking

Pin Description

Pin #	Pin Name	Type	Pin Description
1, 4	VIN	Power/Input	With an internal 1.4 V $V_{IN(UVLO)}$ threshold, VIN supplies the power for the operation of the load switch, the internal control circuitry, and the source terminal of pFET. Bypass the VIN pin to GND with a 2.2 μF (or larger), low-ESR capacitor.
2, 3	ON	Input	A low-to-high transition on this pin initiates the operation of the load switch. ON is an asserted-HIGH, level-sensitive CMOS input with $ON_{V_{IL}} < 0.3 V$ and $ON_{V_{IH}} > 1 V$. As the ON input circuitry does not have an internal pull-down resistor, connect the ON pin directly to a GPIO controller – do not allow this pin to be open circuited.
5, 8	VOUT	Output	Output and drain terminal of MOSFET.
6	\overline{FAULT}	Output	An open drain output, \overline{FAULT} is asserted within $T_{\overline{FAULT}_{LOW}}$ when a $(V_{OUT} + V_{REVERSE} > V_{IN})$ condition is detected. The \overline{FAULT} output is deasserted within $T_{\overline{FAULT}_{HIGH}}$ when the fault condition is removed. Connect an external 10 kΩ resistor from the \overline{FAULT} pin to the system's local logic supply.
7	GND	GND	Ground connection. Connect this pin to system analog or power ground plane.

Ordering Information

Part Number	Type	Production Flow
SLG59M1649V	STDFN 8L	Industrial, -40 °C to 85 °C
SLG59M1649VTR	STDFN 8L (Tape and Reel)	Industrial, -40 °C to 85 °C

SLG59M1649V

An Ultra-small, Low-power 23 mΩ, 4 A,
P-Channel Load Switch with Reverse-Current Blocking

Absolute Maximum Ratings

Parameter	Description	Conditions	Min.	Typ.	Max.	Unit
V_{IN}	Load Switch Input Voltage		-0.3	--	6	V
T_S	Storage Temperature		-65	--	150	°C
ESD _{HBM}	ESD Protection	Human Body Model	2000	--	--	V
ESD _{CDM}	ESD Protection	Charged Device Model	1000	--	--	V
MSL	Moisture Sensitivity Level		1			
θ_{JA}	Thermal Resistance	1.0 x 1.6 mm 8L STDFN	--	82	--	°C/W
$T_{J,MAX}$	Maximum Junction Temperature		--	150	--	°C
MOSFET IDS _{CONT}	Continuous Current from VIN to VOUT	Each channel, $T_J < 150^\circ\text{C}$	--	--	4	A
MOSFET IDS _{PK}	Peak Current from VIN to VOUT	Maximum pulsed switch current, pulse width < 1 ms, 1% duty cycle	--	--	4.5	A

Note: Stresses greater than those listed under "Absolute Maximum Ratings" may cause permanent damage to the device. This is a stress rating only and functional operation of the device at these or any other conditions above those indicated in the operational sections of this specification is not implied. Exposure to absolute maximum rating conditions for extended periods may affect reliability.

Electrical Characteristics

$1.5\text{ V} \leq V_{IN} \leq 5.5\text{ V}$; $C_{IN} = 2.2\ \mu\text{F}$; $T_A = -40^\circ\text{C}$ to 85°C unless otherwise noted. Typical values are at $T_A = 25^\circ\text{C}$.

Parameter	Description	Conditions	Min.	Typ.	Max.	Unit
V_{IN}	Load Switch Input Voltage		1.5	--	5.5	V
$V_{IN(UVLO)}$	V_{IN} Undervoltage Lockout Threshold	$V_{IN} \uparrow$, $V_{ON} = 0\text{ V}$, $R_{LOAD} = 10\ \Omega$	--	--	1.4	V
		$V_{IN} \downarrow$, $V_{ON} = 0\text{ V}$, $R_{LOAD} = 10\ \Omega$	0.5	--	--	V
I_{IN}	Quiescent Load Switch Current	$V_{IN} = 5.25\text{ V}$, ON = HIGH, $I_{DS} = 0\text{ mA}$	--	6.6	11	μA
		$V_{IN} = 1.5\text{ V}$, ON = HIGH, $I_{DS} = 0\text{ mA}$	--	5	8	μA
$I_{IN(OFF)}$	OFF Mode Load Switch Current	$V_{IN} = 5.25\text{ V}$, ON = LOW, $R_{LOAD} = 1\text{ M}\Omega$	--	2	3	μA
		$V_{IN} = 1.5\text{ V}$, ON = LOW, $R_{LOAD} = 1\text{ M}\Omega$	--	0.8	2	μA
RDS _{ON}	ON Resistance	$T_A = 25^\circ\text{C}$, $V_{IN} = 5.0\text{ V}$, $I_{DS} = -200\text{ mA}$	--	23	28	mΩ
		$T_A = 25^\circ\text{C}$, $V_{IN} = 2.5\text{ V}$, $I_{DS} = -200\text{ mA}$	--	31	38	mΩ
		$T_A = 25^\circ\text{C}$, $V_{IN} = 1.5\text{ V}$, $I_{DS} = -200\text{ mA}$	--	42	50	mΩ
		$T_A = 85^\circ\text{C}$, $V_{IN} = 5.0\text{ V}$, $I_{DS} = -200\text{ mA}$	--	27	32	mΩ
		$T_A = 85^\circ\text{C}$, $V_{IN} = 2.5\text{ V}$, $I_{DS} = -200\text{ mA}$	--	37	44	mΩ
		$T_A = 85^\circ\text{C}$, $V_{IN} = 1.5\text{ V}$, $I_{DS} = -200\text{ mA}$	--	48	58	mΩ
MOSFET IDS	Current from VIN to VOUT	Continuous	--	--	4	A
$V_{REVERSE}$	Reverse-current Voltage Threshold		--	50	--	mV
$I_{REVERSE}$	Reverse-current Leakage Current after Reverse Current Event	$V_{OUT} - V_{IN} > V_{REVERSE}$; $T_A = 25^\circ\text{C}$; ON = GND	--	1	--	μA
V_{ON}	ON Pin Voltage Range		0		V_{IN}	V
$I_{ON(Leakage)}$	ON Pin Leakage Current	$1.4\text{ V} \leq V_{ON} \leq V_{IN}$ or $V_{ON} = \text{GND}$	--	--	1	μA
ON_ V_{IH}	ON Pin Input High Voltage		1	--	V_{IN}	V

SLG59M1649V

An Ultra-small, Low-power 23 mΩ, 4 A, P-Channel Load Switch with Reverse-Current Blocking

Electrical Characteristics (continued)

$1.5\text{ V} \leq V_{IN} \leq 5.5\text{ V}$; $C_{IN} = 2.2\text{ }\mu\text{F}$; $T_A = -40\text{ }^\circ\text{C}$ to $85\text{ }^\circ\text{C}$ unless otherwise noted. Typical values are at $T_A = 25\text{ }^\circ\text{C}$.

Parameter	Description	Conditions	Min.	Typ.	Max.	Unit
ON_VIL	ON Pin Input Low Voltage		-0.3	0	0.3	V
ON_HYS	ON Hysteresis		--	60	--	mV
R_DISCHRG	Output Discharge Resistance	$V_{IN} = 5\text{ V}$; $V_{OUT} < 0.4\text{ V}$	50	80	120	Ω
T_REV	Reverse-current Detect Response Delay	$V_{IN} = 5\text{ V}$	--	10	--	μs
T_REARM	Reverse Detect Rearm Time		--	1.5	--	ms
T_ON_Delay	ON Delay Time	50% ON to 50% V_{OUT} \uparrow ; $T_A = 25\text{ }^\circ\text{C}$, $V_{IN} = 5\text{ V}$; $R_{LOAD} = 10\text{ }\Omega$, $C_{LOAD} = 0.1\text{ }\mu\text{F}$	--	180	235	μs
		50% ON to 50% V_{OUT} \uparrow ; $T_A = 25\text{ }^\circ\text{C}$, $V_{IN} = 1.5\text{ V}$; $R_{LOAD} = 10\text{ }\Omega$, $C_{LOAD} = 0.1\text{ }\mu\text{F}$	--	110	145	μs
T_VOUT(R)	V_{OUT} Rise Time	10% to 90% V_{OUT} \uparrow ; $T_A = 25\text{ }^\circ\text{C}$, $V_{IN} = 5\text{ V}$; $R_{LOAD} = 10\text{ }\Omega$, $C_{LOAD} = 0.1\text{ }\mu\text{F}$	--	130	170	μs
		10% to 90% V_{OUT} \uparrow ; $T_A = 25\text{ }^\circ\text{C}$, $V_{IN} = 1.5\text{ V}$; $R_{LOAD} = 10\text{ }\Omega$, $C_{LOAD} = 0.1\text{ }\mu\text{F}$	--	66	86	μs
T_VOUT(F)	V_{OUT} Fall Time	90% to 10% V_{OUT} \downarrow ; $T_A = 25\text{ }^\circ\text{C}$, $V_{IN} = 5\text{ V}$; $R_{LOAD} = 10\text{ }\Omega$, $C_{LOAD} = 0.1\text{ }\mu\text{F}$	--	2.2	3.6	μs
		90% to 10% V_{OUT} \downarrow ; $T_A = 25\text{ }^\circ\text{C}$, $V_{IN} = 1.5\text{ V}$; $R_{LOAD} = 10\text{ }\Omega$, $C_{LOAD} = 0.1\text{ }\mu\text{F}$	--	2.2	3.6	μs
T_OFF_Delay	OFF Delay Time	50% ON to 50% V_{OUT} \downarrow ; $T_A = 25\text{ }^\circ\text{C}$, $V_{IN} = 5\text{ V}$; $R_{LOAD} = 10\text{ }\Omega$, $C_{LOAD} = 0.1\text{ }\mu\text{F}$	--	3.5	5	μs
		50% ON to 50% V_{OUT} \downarrow ; $T_A = 25\text{ }^\circ\text{C}$, $V_{IN} = 1.5\text{ V}$; $R_{LOAD} = 10\text{ }\Omega$, $C_{LOAD} = 0.1\text{ }\mu\text{F}$	--	5	7	μs
T_FAULT_LOW	$\overline{\text{FAULT}}$ Assertion Time	Reverse-voltage Detection to $\overline{\text{FAULT}} \downarrow$; $1.5\text{ V} \leq V_{IN} \leq 5\text{ V}$; ON = Low	--	2	--	μs
		$1.5\text{ V} \leq V_{IN} \leq 5\text{ V}$; ON = High	--	0.5	--	μs
T_FAULT_HIGH	$\overline{\text{FAULT}}$ De-assertion Time	Delay to $\overline{\text{FAULT}} \uparrow$ after fault condition is removed; $1.5\text{ V} \leq V_{IN} \leq 5\text{ V}$; ON = Low	--	7	--	ms
		$1.5\text{ V} \leq V_{IN} \leq 5\text{ V}$; ON = High	--	2	--	ms
$\overline{\text{FAULT}}_{VOL}$	$\overline{\text{FAULT}}$ Output Low Voltage	$I_{\overline{\text{FAULT}}} = 1\text{ mA}$	--	--	0.2	V

SLG59M1649V

An Ultra-small, Low-power 23 mΩ, 4 A,
P-Channel Load Switch with Reverse-Current Blocking

T_{ON_Delay} , $V_{OUT(SR)}$, and T_{Total_ON} Timing Details

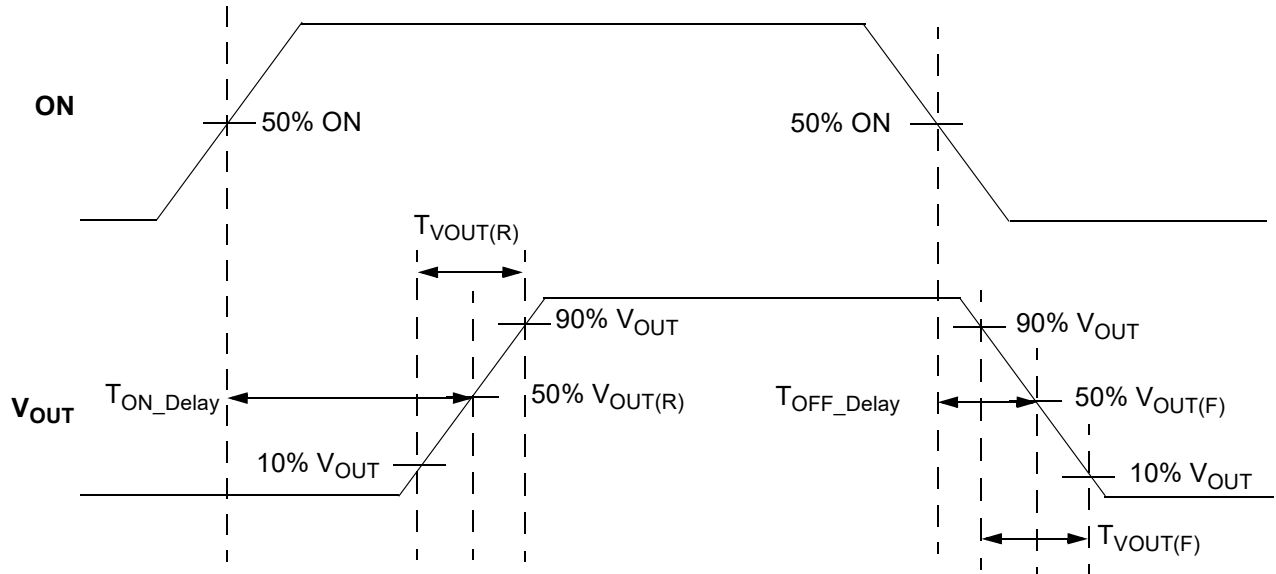

SLG59M1649V

An Ultra-small, Low-power 23 mΩ, 4 A, P-Channel Load Switch with Reverse-Current Blocking

RDS_{ON} vs. V_{IN} and Temperature

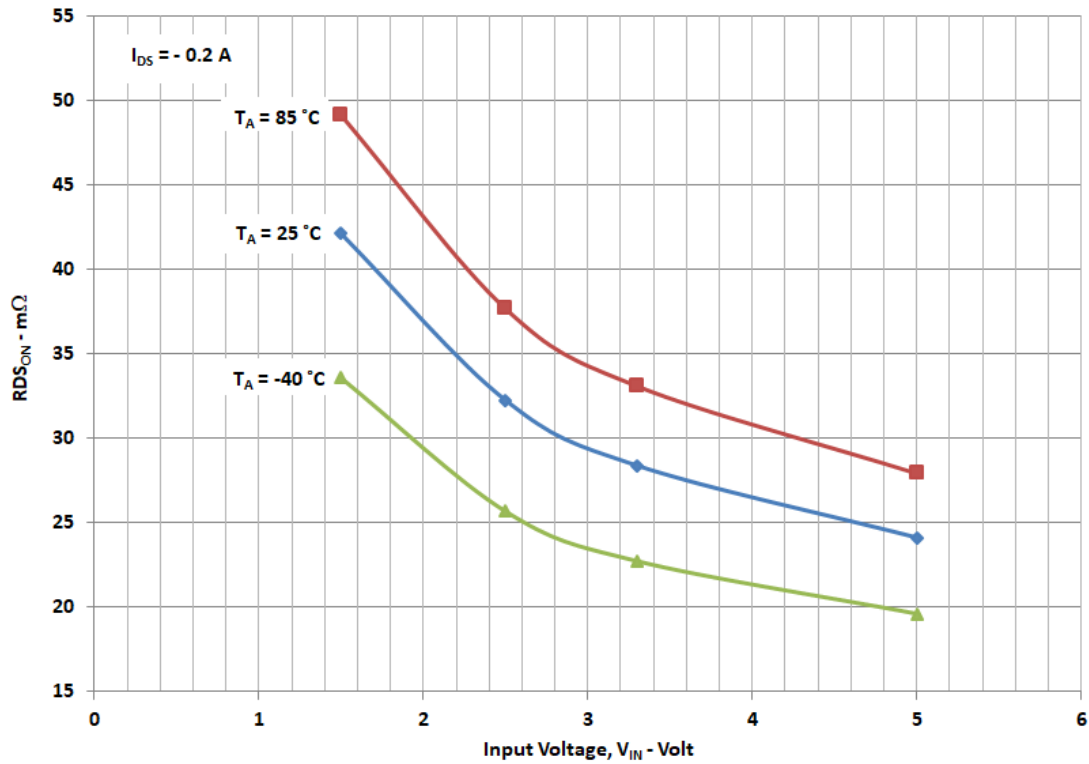

RDS_{ON} vs. Temperature and V_{IN}

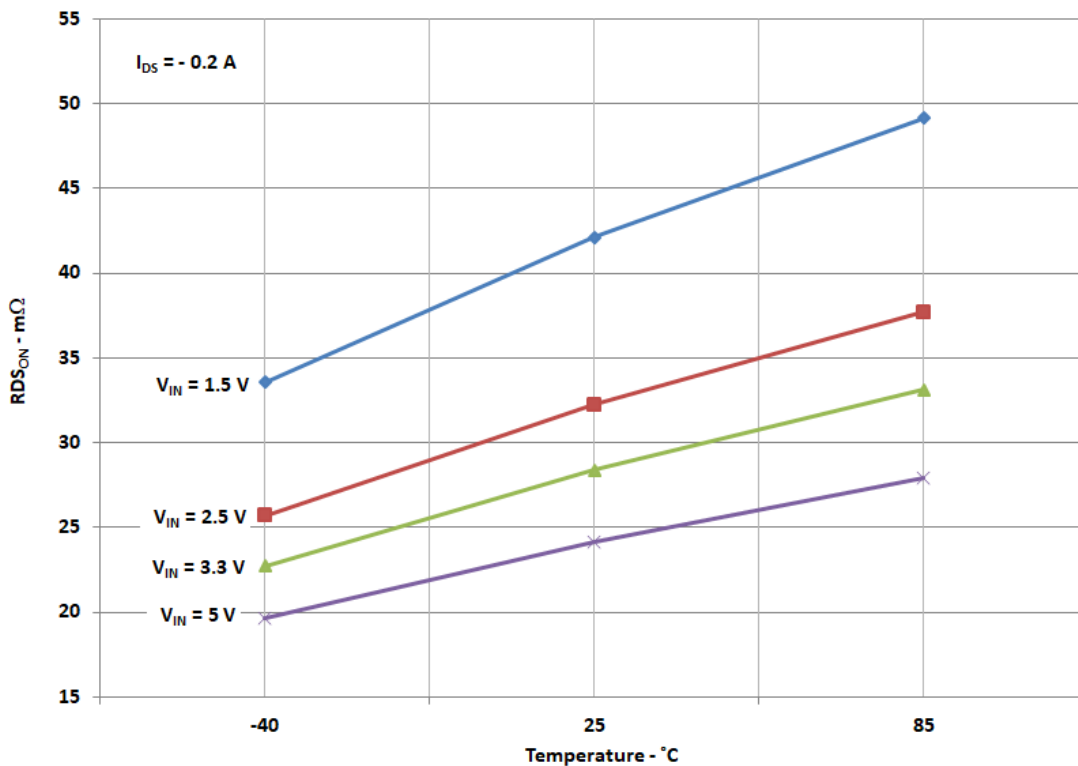

SLG59M1649V

An Ultra-small, Low-power 23 mΩ, 4 A, P-Channel Load Switch with Reverse-Current Blocking

V_{IN} Inrush Current Details

When the SLG59M1649V is enabled with ON ↑, the load switch closes to charge the V_{OUT} output capacitor to V_{IN}. The charging current drawn from V_{IN} is commonly referred to as “V_{IN} inrush current” and can cause the input power source to collapse if the V_{IN} inrush current is too high.

Since the V_{OUT} rise time of the SLG59M1649V is fixed, V_{IN} inrush current is then a function of the output capacitance at V_{OUT}. The expression relating V_{IN} inrush current, the SLG59M1649V V_{OUT} rise time, and C_{LOAD} is:

$$V_{IN} \text{ Inrush Current} = C_{LOAD} \times \frac{\Delta V_{OUT}(10\% \text{ to } 90\%)}{T_{VOUT(R)}(10\% \text{ to } 90\%)}$$

where in this expression ΔV_{OUT} is equivalent to V_{IN} if the initial SLG59M1649V's output voltages are zero.

In the table below are examples of V_{IN} inrush currents assuming zero initial charge on C_{LOAD} as a function of V_{IN}.

V _{IN} (V)	V _{OUT} Rise Time (μs)	C _{LOAD} (μF)	Inrush Current (mA)
1.5	66	0.1	1.8
5	130	0.1	3.1

Since the relationship is linear and if C_{LOAD} were increased to 1 μF, then the V_{IN} inrush currents would be 10x higher in either example. If a large C_{LOAD} capacitor is required in the application and depending upon the strength of the input power source, it may very well be necessary to increase the C_{IN}-to-C_{LOAD} ratio to minimize V_{IN} droop during turn-on.

For other V_{OUT} rise time options, please contact Renesas for additional information.

Power Dissipation

The junction temperature of the SLG59M1649V depends on factors such as board layout, ambient temperature, external air flow over the package, load current, and the RDS_{ON}-generated voltage drop across each power MOSFET. While the primary contributor to the increase in the junction temperature of the SLG59M1649V is the power dissipation of its power MOSFETs, its power dissipation and the junction temperature in nominal operating mode can be calculated using the following equations:

$$PD_{TOTAL} = RDS_{ON} \times I_{DS}^2$$

where:

PD_{TOTAL} = Total package power dissipation, in Watts (W)

RDS_{ON} = Power MOSFET ON resistance, in Ohms (Ω)

I_{DS} = Output current, in Amps (A)

and

$$T_J = PD_{TOTAL} \times \theta_{JA} + T_A$$

where:

T_J = Die junction temperature, in Celsius degrees (°C)

θ_{JA} = Package thermal resistance, in Celsius degrees per Watt (°C/W) – highly dependent on pcb layout

T_A = Ambient temperature, in Celsius degrees (°C)

SLG59M1649V

An Ultra-small, Low-power 23 mΩ, 4 A, P-Channel Load Switch with Reverse-Current Blocking

Power Dissipation (continued)

In nominal operating mode, the SLG59M1649V's power dissipation can also be calculated by taking into account the voltage drop across each switch ($V_{IN}-V_{OUT}$) and the magnitude of that channel's output current (I_{DS}):

$$PD_{TOTAL} = (V_{IN}-V_{OUT}) \times I_{DS} \text{ or}$$

$$PD_{TOTAL} = (V_{IN} - (R_{LOAD} \times I_{DS})) \times I_{DS}$$

where:

PD_{TOTAL} = Total package power dissipation, in Watts (W)

V_{IN} = Input Voltage, in Volts (V)

R_{LOAD} = Output Load Resistance, in Ohms (Ω)

I_{DS} = Output current, in Amps (A)

V_{OUT} = Output voltage, or $R_{LOAD} \times I_{DS}$

Power Dissipation Derating Curve

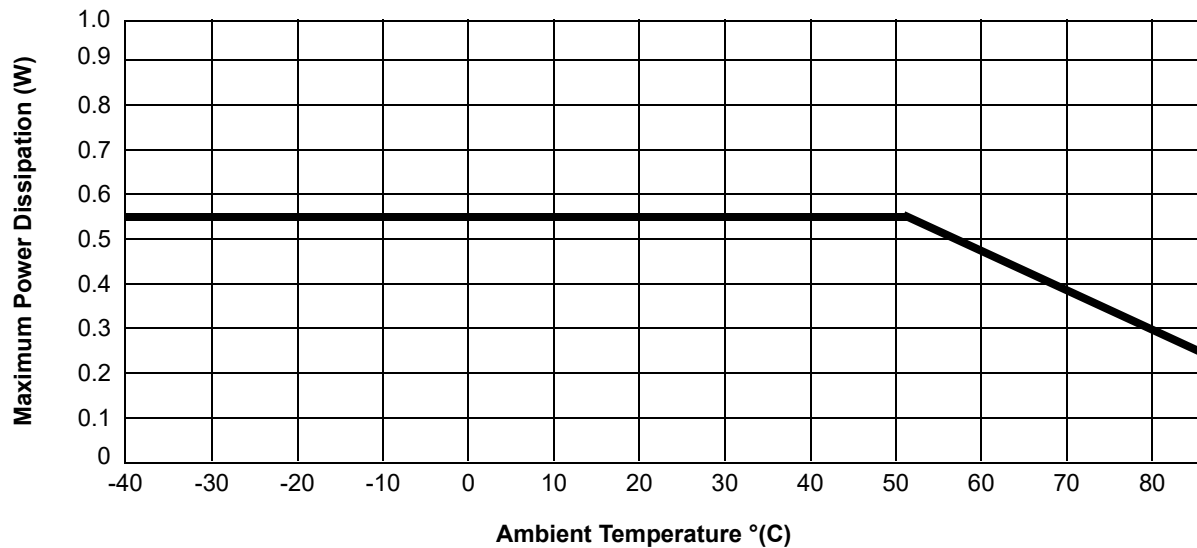

Note: Each V_{IN} , V_{OUT} = 1 in² 1.2 oz. copper on FR4

SLG59M1649V

An Ultra-small, Low-power 23 mΩ, 4 A, P-Channel Load Switch with Reverse-Current Blocking

SLG59M1649V Layout Suggestion

 Exposed Pad (PKG face down)

 Recommended Land Pattern (PKG face down)

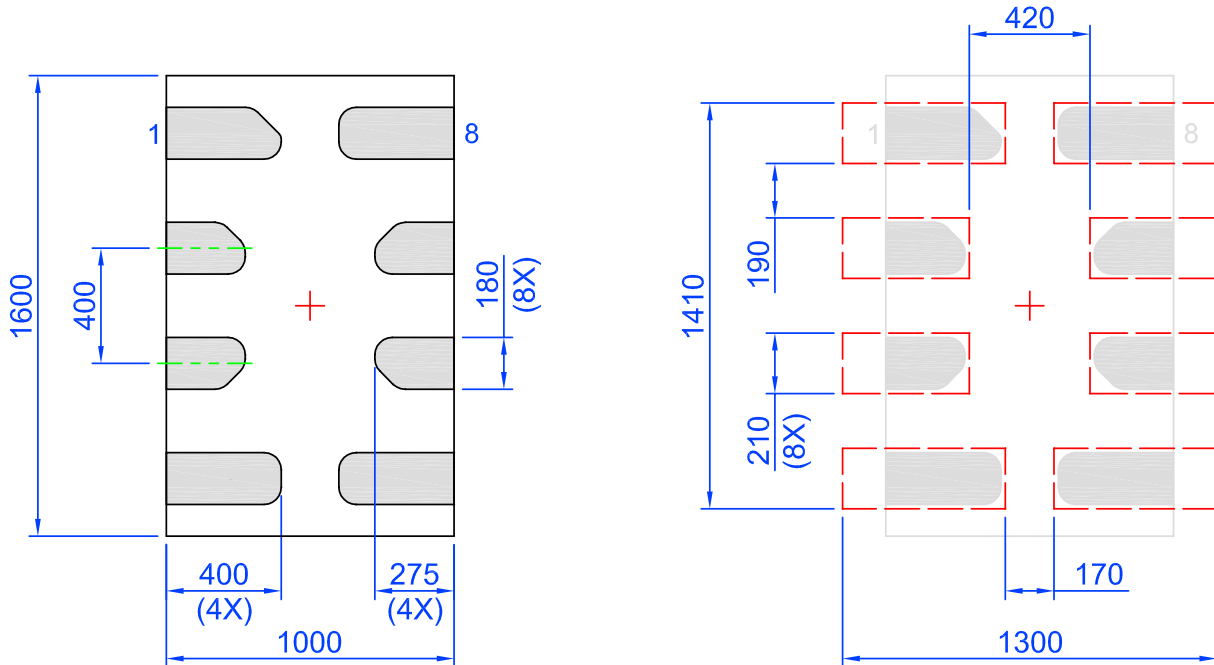

Note: All dimensions shown in micrometers (μm)

Recommended PCB Layout for external power traces

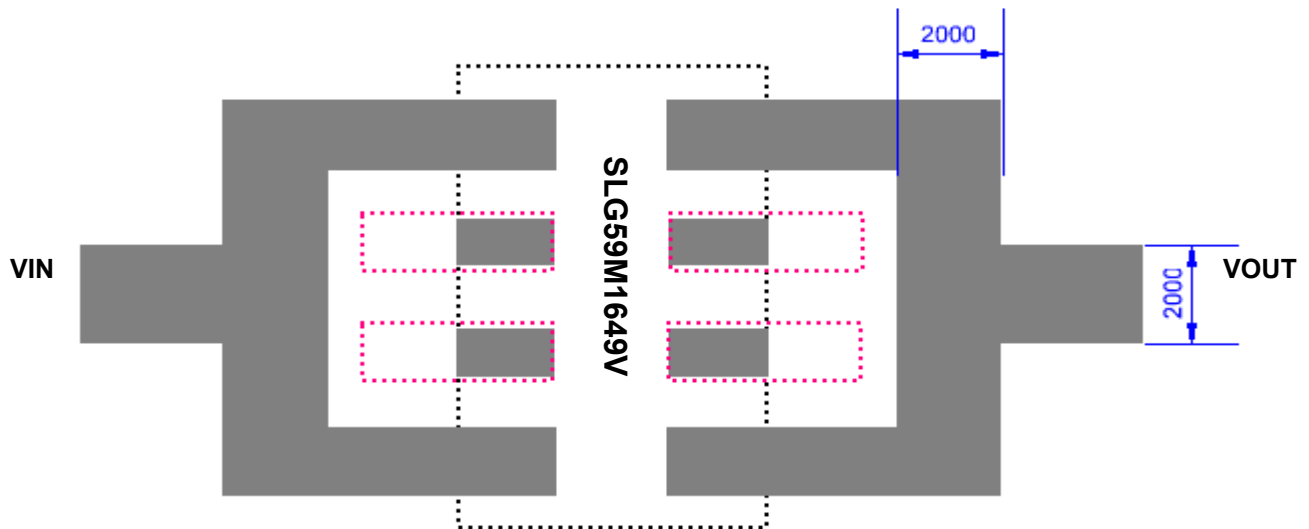

Note: All dimensions shown in μm (micrometers)

SLG59M1649V

An Ultra-small, Low-power 23 m Ω , 4 A, P-Channel Load Switch with Reverse-Current Blocking

Layout Guidelines:

1. Since the VIN and VOUT pins dissipate most of the heat generated during high-load current operation, it is highly recommended to make power traces as short, direct, and wide as possible. A good practice is to make power traces with absolute minimum widths of 15 mils (0.381 mm) per Ampere. A representative layout, shown in Figure 1, illustrates proper techniques for heat to transfer as efficiently as possible out of the device;
2. To minimize the effects of parasitic trace inductance on normal operation, it is recommended to connect input C_{IN} and output C_{LOAD} low-ESR capacitors as close as possible to the SLG59M1649V's VIN and VOUT pins;
3. The GND pin should be connected to system analog or power ground plane.
4. 2 oz. copper is recommended for high current operation.

SLG59M1649V Evaluation Board:

A GreenFET Evaluation Board for SLG59M1649V is designed according to the statements above and is illustrated on Figure 1. Please note that evaluation board has D_Sense and S_Sense pads. They cannot carry high currents and dedicated only for RDS_{ON} evaluation.

Please solder your SLG59M1649V here

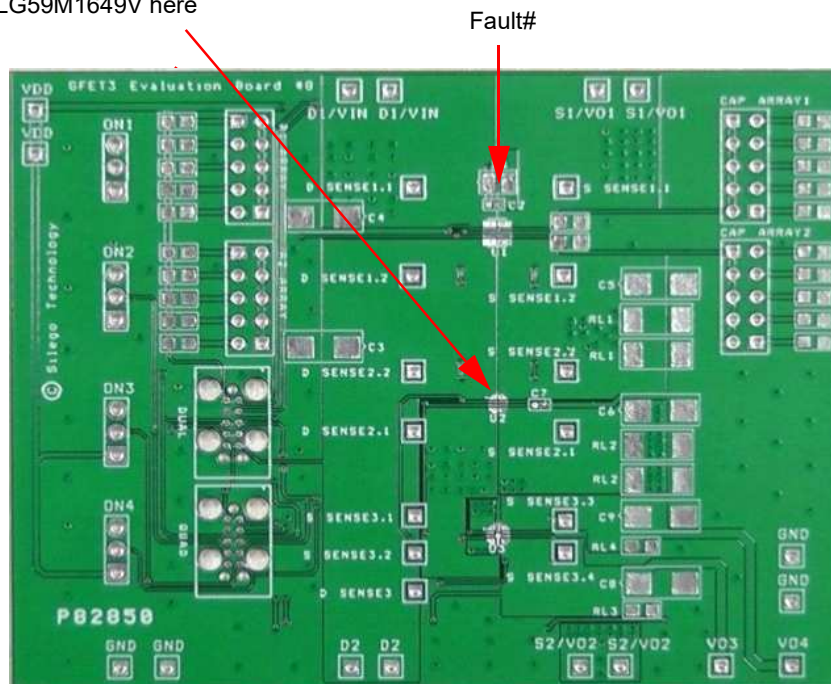

Figure 1. SLG59M1649V Evaluation Board.

SLG59M1649V

An Ultra-small, Low-power 23 mΩ, 4 A, P-Channel Load Switch with Reverse-Current Blocking

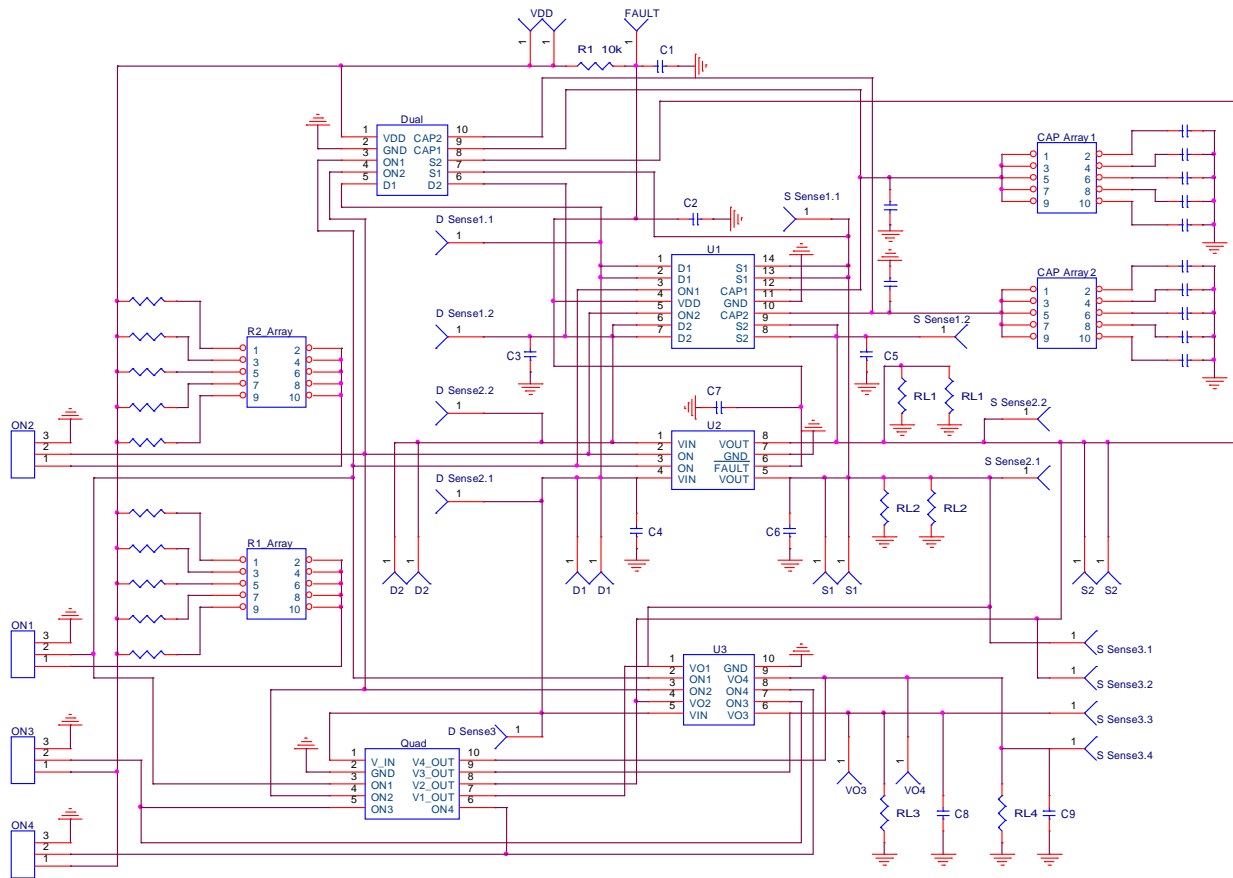

Figure 2. SLG59M1649V Evaluation Board Connection Circuit.

SLG59M1649V

An Ultra-small, Low-power 23 mΩ, 4 A, P-Channel Load Switch with Reverse-Current Blocking

Basic Test Setup and Connections

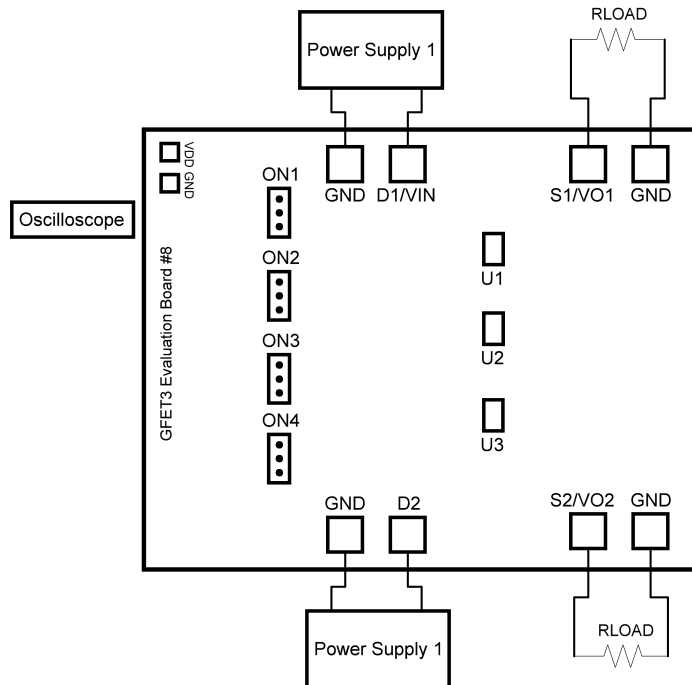

Figure 3. Typical connections for GreenFET Evaluation.

EVB Configuration

1. Connect oscilloscope probes to D1/VIN, D2, S1/VO1, S2/VO2, ON etc.;
2. Use VDD connector to have logic high level for FAULT and ON signals;
3. Turn on Power Supply 1 and set desired V_{IN} from 1.5 V...5.5 V range;
4. Toggle the ON signal High or Low to observe SLG59M1649V operation.

SLG59M1649V

An Ultra-small, Low-power 23 mΩ, 4 A,
P-Channel Load Switch with Reverse-Current Blocking

Package Top Marking System Definition

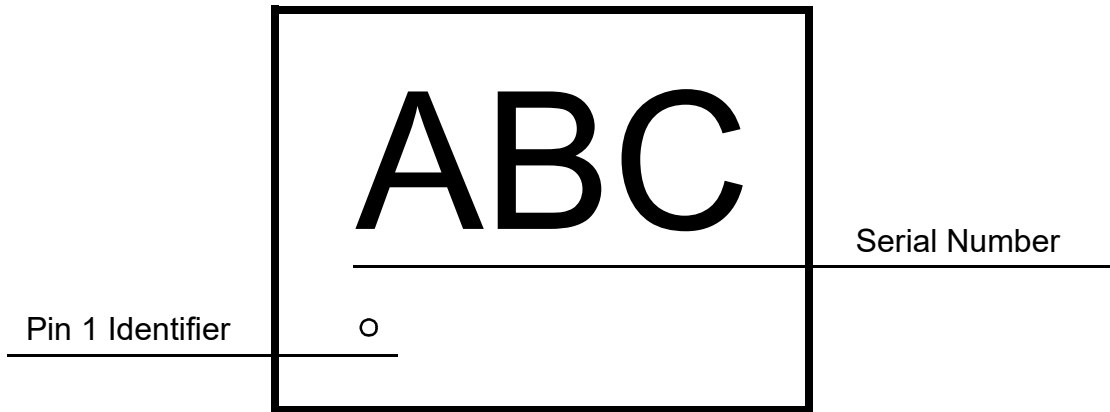

ABC - 3 alphanumeric Part Serial Number
where A, B, or C can be A-Z and 0-9

SLG59M1649V

An Ultra-small, Low-power 23 mΩ, 4 A,
P-Channel Load Switch with Reverse-Current Blocking

Package Drawing and Dimensions

8 Lead STDFN Package 1.0 x 1.6 mm

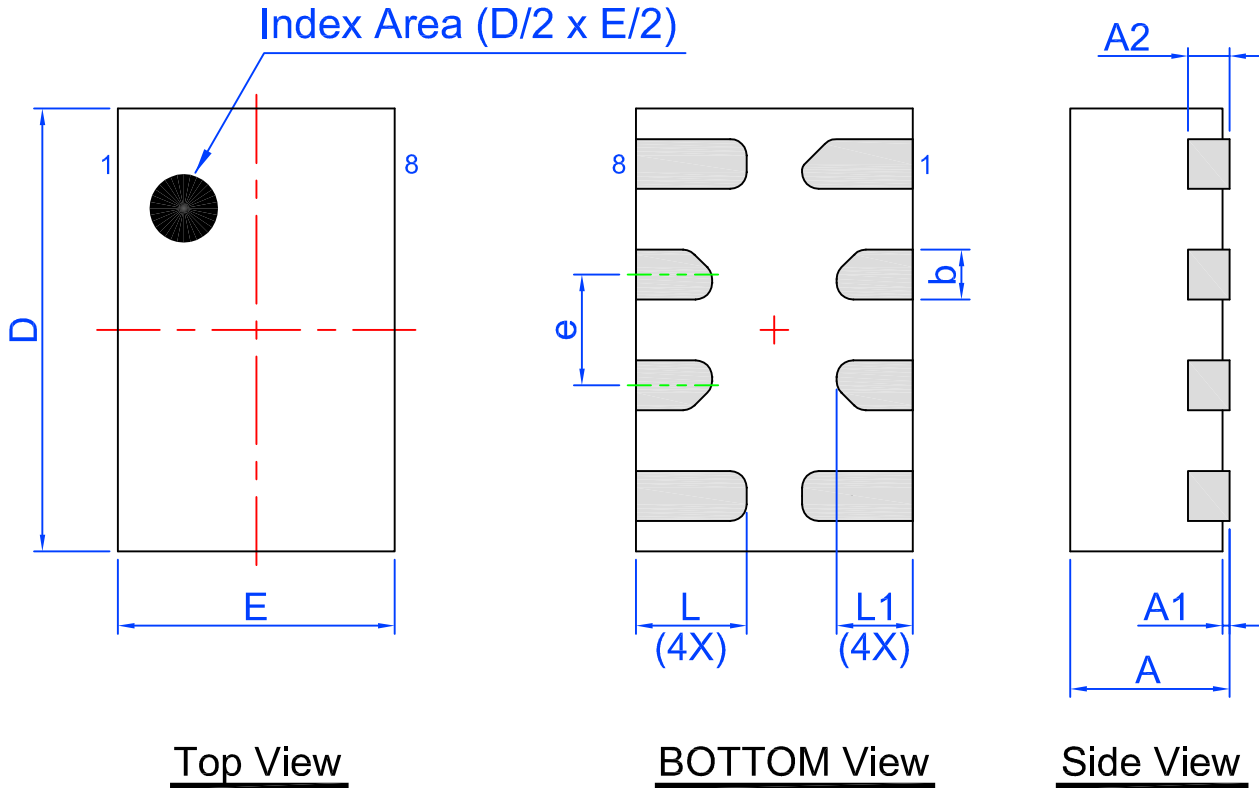

Unit: mm

Symbol	Min	Nom.	Max	Symbol	Min	Nom.	Max
A	0.50	0.55	0.60	D	1.55	1.60	1.65
A1	0.005	-	0.050	E	0.95	1.00	1.05
A2	0.10	0.15	0.20	L	0.35	0.40	0.45
b	0.13	0.18	0.23	L1	0.225	0.275	0.325
e	0.40 BSC						

SLG59M1649V

An Ultra-small, Low-power 23 mΩ, 4 A,
P-Channel Load Switch with Reverse-Current Blocking

Tape and Reel Specifications

Package Type	# of Pins	Nominal Package Size [mm]	Max Units		Reel & Hub Size [mm]	Leader (min)		Trailer (min)		Tape Width [mm]	Part Pitch [mm]
			per Reel	per Box		Pockets	Length [mm]	Pockets	Length [mm]		
STDFN 8L 1x1.6mm 0.4P FCD Green	8	1.0 x 1.6 x 0.55	3,000	3,000	178 / 60	100	400	100	400	8	4

Carrier Tape Drawing and Dimensions

Package Type	Pocket BTM Length	Pocket BTM Width	Pocket Depth	Index Hole Pitch	Pocket Pitch	Index Hole Diameter	Index Hole to Tape Edge	Index Hole to Pocket Center	Tape Width
	A0	B0	K0	P0	P1	D0	E	F	W
STDFN 8L 1x1.6mm 0.4P FCD Green	1.12	1.72	0.7	4	4	1.55	1.75	3.5	8

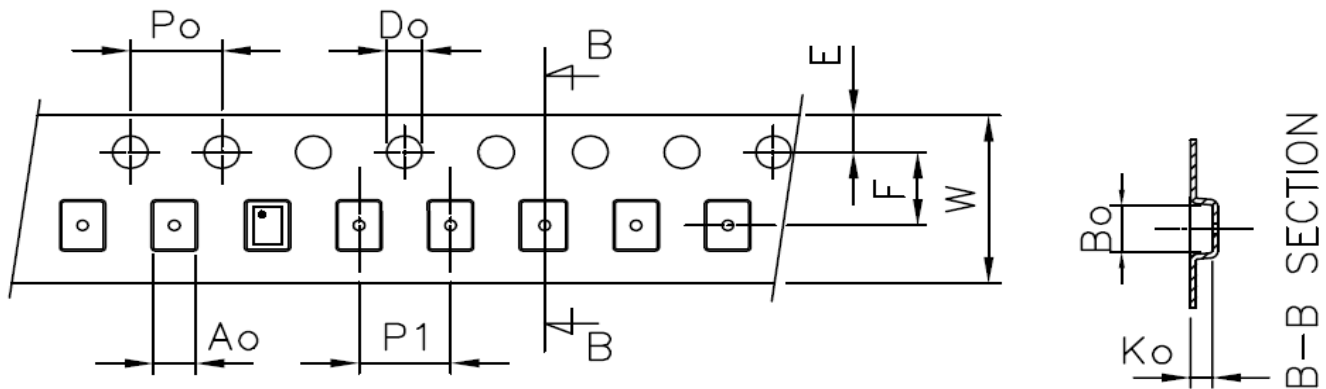

Recommended Reflow Soldering Profile

Please see IPC/JEDEC J-STD-020: latest revision for reflow profile based on package volume of 0.88 mm³ (nominal). More information can be found at www.jedec.org.

SLG59M1649V

An Ultra-small, Low-power 23 mΩ, 4 A,
P-Channel Load Switch with Reverse-Current Blocking

Revision History

Date	Version	Change
2/2/2022	1.02	Updated Company name and logo Fixed typos
12/12/2018	1.01	Updated UVLO spec Updated Style and Formatting Updated Charts Added Layout Guidelines Fixed typos
2/23/2017	1.00	Production Release

IMPORTANT NOTICE AND DISCLAIMER

RENESAS ELECTRONICS CORPORATION AND ITS SUBSIDIARIES (“RENESAS”) PROVIDES TECHNICAL SPECIFICATIONS AND RELIABILITY DATA (INCLUDING DATASHEETS), DESIGN RESOURCES (INCLUDING REFERENCE DESIGNS), APPLICATION OR OTHER DESIGN ADVICE, WEB TOOLS, SAFETY INFORMATION, AND OTHER RESOURCES “AS IS” AND WITH ALL FAULTS, AND DISCLAIMS ALL WARRANTIES, EXPRESS OR IMPLIED, INCLUDING, WITHOUT LIMITATION, ANY IMPLIED WARRANTIES OF MERCHANTABILITY, FITNESS FOR A PARTICULAR PURPOSE, OR NON-INFRINGEMENT OF THIRD-PARTY INTELLECTUAL PROPERTY RIGHTS.

These resources are intended for developers who are designing with Renesas products. You are solely responsible for (1) selecting the appropriate products for your application, (2) designing, validating, and testing your application, and (3) ensuring your application meets applicable standards, and any other safety, security, or other requirements. These resources are subject to change without notice. Renesas grants you permission to use these resources only to develop an application that uses Renesas products. Other reproduction or use of these resources is strictly prohibited. No license is granted to any other Renesas intellectual property or to any third-party intellectual property. Renesas disclaims responsibility for, and you will fully indemnify Renesas and its representatives against, any claims, damages, costs, losses, or liabilities arising from your use of these resources. Renesas' products are provided only subject to Renesas' Terms and Conditions of Sale or other applicable terms agreed to in writing. No use of any Renesas resources expands or otherwise alters any applicable warranties or warranty disclaimers for these products.

(Disclaimer Rev.1.01 Jan 2024)

Corporate Headquarters

TOYOSU FORESIA, 3-2-24 Toyosu,
Koto-ku, Tokyo 135-0061, Japan
www.renesas.com

Trademarks

Renesas and the Renesas logo are trademarks of Renesas Electronics Corporation. All trademarks and registered trademarks are the property of their respective owners.

Contact Information

For further information on a product, technology, the most up-to-date version of a document, or your nearest sales office, please visit www.renesas.com/contact-us/.