

TP65H070G4LSGB

650V SuperGaN® GaN FET in PQFN (source tab)

Description

The TP65H070G4LSGB 650V, 72mΩ Gallium Nitride (GaN) FET is a normally-off device. It combines state-of-the-art high voltage GaN HEMT and low voltage silicon MOSFET technologies—offering superior reliability and performance.

The Gen IV SuperGaN® platform uses advanced epi and patented design technologies to simplify manufacturability while improving efficiency over silicon via lower gate charge, output capacitance, crossover loss, and reverse recovery charge

Related Literature

- [Recommended External Circuitry for GaN FETs](#)
- [Printed Circuit Board Layout and Probing](#)
- [Recommendations for Vapor Phase Reflow](#)
- [Paralleling GaN FETs](#)
- [PQFN Tape and Reel Information](#)
- [Low cost driver solution](#)

Ordering Information

Part Number	Package	Package Configuration
TP65H070G4LSGB-TR	8x8 PQFN	Source

* "-TR" suffix refers to tape and reel. Refer to AN0012 for details.

TP65H070G4LSGB
PQFN
(Bottom view)

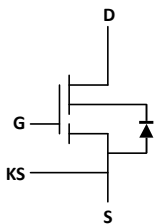
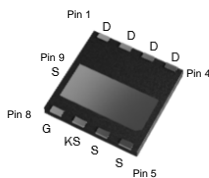

Cascode Schematic Symbol

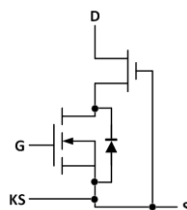

Cascode Device Structure

Features

- Gen IV technology
- JEDEC-qualified GaN technology
- Dynamic $R_{DS(on)eff}$ production tested
- Robust design, defined by
 - Wide gate safety margin
 - Transient over-voltage capability
- Very low Q_{RR}
- Reduced crossover loss
- RoHS compliant and Halogen-free packaging

Benefits

- Achieves increased efficiency in both hard- and soft-switched circuits
 - Increased power density
 - Reduced system size and weight
 - Overall lower system cost
- Easy to drive with commonly-used gate drivers
- GSD pin layout improves high speed design

Applications

- Datacom
- Broad industrial
- PV inverter
- Servo motor
- Consumer
- Computing



Key Specifications

V_{DSS} (V)	650
$V_{DSS(TR)}$ (V)	800
$R_{DS(on)eff}$ (mΩ) max*	85
Q_{oss} (nC) typ	78
Q_G (nC) typ	8.4

* Dynamic on-resistance; see Figures 18 and 19

Absolute Maximum Ratings ($T_c=25\text{ }^\circ\text{C}$ unless otherwise stated.)

Symbol	Parameter	Limit Value	Unit	
V_{DSS}	Drain to source voltage ($T_J = -55\text{ }^\circ\text{C}$ to $150\text{ }^\circ\text{C}$)	650	V	
$V_{DSS(TR)}$	Transient drain to source voltage ^(a)	800		
V_{GSS}	Gate to source voltage	± 20		
P_D	Maximum power dissipation @ $T_c=25\text{ }^\circ\text{C}$	96	W	
I_D	Continuous drain current @ $T_c=25\text{ }^\circ\text{C}$ ^(b)	29	A	
	Continuous drain current @ $T_c=100\text{ }^\circ\text{C}$ ^(b)	18.4	A	
I_{DM}	Pulsed drain current (pulse width: $10\mu\text{s}$)	120	A	
T_c	Operating temperature	Case	-55 to $+150$	$^\circ\text{C}$
T_J		Junction	-55 to $+150$	$^\circ\text{C}$
T_s	Storage temperature	-55 to $+150$	$^\circ\text{C}$	
T_{SOLD}	Reflow soldering temperature ^(c)	260	$^\circ\text{C}$	

Notes:

- a. In off-state, spike duration $<30\text{ }\mu\text{s}$, non-repetitive
- b. For increased stability at high current operation, see Circuit Implementation on page 3
- c. Reflow MSL3

Thermal Resistance

Symbol	Parameter	Typical	Unit
$R_{\theta JC}$	Junction-to-case	1	$^\circ\text{C}/\text{W}$
$R_{\theta JA}$	Junction-to-ambient	62	$^\circ\text{C}/\text{W}$

Circuit Implementation

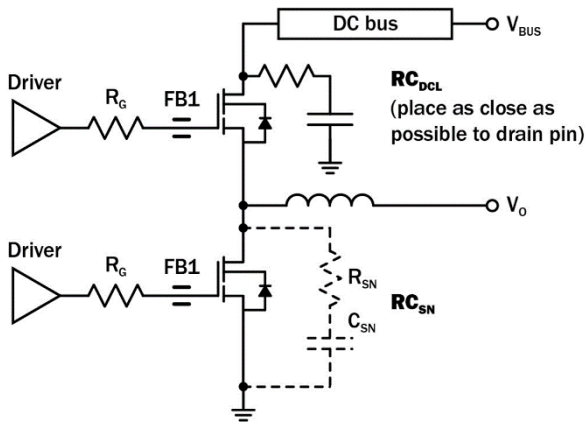

Simplified Half-bridge Schematic (See also on Figure 13)

For additional gate driver options/configurations, please see Application Note [Recommended External Circuitry for GaN FETs](#)

Layout Recommendations

Gate Loop:

- Gate Driver: SiLab Si823x/Si827x
- Keep gate loop compact
- Minimize coupling with power loop

Power loop: (For reference see page 13)

- Minimize power loop path inductance
- Minimize switching node coupling with high and low power plane
- Add DC bus snubber to reduce to voltage ringing
- Add Switching node snubber for high current operation

Recommended gate drive: (0V, 12V) with $R_G = 50\Omega$

Gate Ferrite Bead (FB1)	Required DC Link RC Snubber (RC_{DCL}) ^(d)	Recommended Switching Node RC Snubber (RC_{SN}) ^(e)
200 – 300 Ω at 100MHz	10nF + 5 Ω	Not necessary ^(e)

Notes:

- d. RC_{DCL} should be placed as close as possible to the drain pin
- e. RC_{SN} (68pF + 15 Ω) is needed only if R_e is smaller than recommendations

Electrical Parameter ($T_J=25\text{ }^\circ\text{C}$ unless otherwise stated)

Symbol	Parameter	Min	Typ	Max	Unit	Test Conditions
Forward Device Characteristics						
$V_{(BL)DSS}$	Drain-source voltage	650	—	—	V	$V_{GS}=0V$
$V_{GS(th)}$	Gate threshold voltage	3.2	4	4.6	V	$V_{DS}=V_{GS}$, $I_D=0.7mA$
$R_{DS(on)eff}$	Drain-source on-resistance ^(f)	—	72	85	m Ω	$V_{GS}=10V$, $I_D=16A$, $T_J=25\text{ }^\circ\text{C}$
		—	148	—		$V_{GS}=10V$, $I_D=16A$, $T_J=150\text{ }^\circ\text{C}$
I_{DSS}	Drain-to-source leakage current	—	3	30	μA	$V_{DS}=650V$, $V_{GS}=0V$, $T_J=25\text{ }^\circ\text{C}$
		—	12	—		$V_{DS}=650V$, $V_{GS}=0V$, $T_J=150\text{ }^\circ\text{C}$
I_{GSS}	Gate-to-source forward leakage current	—	—	100	nA	$V_{GS}=20V$
	Gate-to-source reverse leakage current	—	—	-100		$V_{GS}=-20V$
C_{ISS}	Input capacitance	—	600	—	pF	$V_{GS}=0V$, $V_{DS}=400V$, $f=1MHz$
C_{OSS}	Output capacitance	—	74	—		
C_{RSS}	Reverse transfer capacitance	—	2	—		
$C_{O(er)}$	Output capacitance, energy related ^(g)	—	109	—	pF	$V_{GS}=0V$, $V_{DS}=0V$ to 400V
$C_{O(tr)}$	Output capacitance, time related ^(h)	—	200	—		
Q_G	Total gate charge	—	8.4	—	nC	$V_{DS}=400V$, $V_{GS}=0V$ to 10V, $I_D=16A$
Q_{GS}	Gate-source charge	—	3.3	—		
Q_{GD}	Gate-drain charge	—	2.3	—		
Q_{OSS}	Output charge	—	78	—	nC	$V_{GS}=0V$, $V_{DS}=0V$ to 400V
$t_{D(on)}$	Turn-on delay	—	27	—	ns	$V_{DS}=400V$, $V_{GS}=0V$ to 12V, $I_D=16A$, $R_G=50\Omega$
t_R	Rise time	—	9	—		
$t_{D(off)}$	Turn-off delay	—	71	—		
t_F	Fall time	—	6.5	—		

Notes:

f. Dynamic on-resistance; see Figures 5 and 6 for test circuit and conditions

g. Equivalent capacitance to give same stored energy as V_{DS} rises from 0V to 400V

h. Equivalent capacitance to give same charging time as V_{DS} rises from 0V to 400V

Electrical Parameters ($T_J=25^\circ\text{C}$ unless otherwise stated)

Symbol	Parameter	Min	Typ	Max	Unit	Test Conditions
Reverse Device Characteristics						
I_S	Reverse current	—	—	16	A	$V_{GS}=0V$, $T_C=100^\circ\text{C}$, $\leq 25\%$ duty cycle
V_{SD}	Reverse voltage ⁽ⁱ⁾	—	2.2	2.6	V	$V_{GS}=0V$, $I_S=16A$
		—	1.6	1.9		$V_{GS}=0V$, $I_S=8A$
t_{RR}	Reverse recovery time	—	34	—	ns	$I_S=16A$, $V_{DD}=400V$, $di/dt=1000A/ms$
Q_{RR}	Reverse recovery charge ^(j)	—	0	—	nC	
$(di/dt)_{RDMC}$	Reverse diode di/dt ^(k)	—	—	1900	A/ μs	

Notes:

i. Includes dynamic $R_{DS(on)}$ effect

j. Excludes Q_{oss}

k. Reverse conduction di/dt will not exceed this max value with recommended R_{θ} .

Typical Characteristics ($T_c=25^\circ\text{C}$ unless otherwise stated)

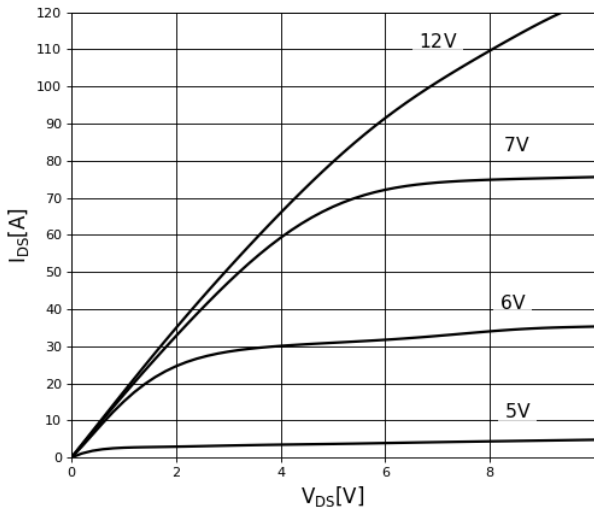

Figure 1. Typical Output Characteristics $T_J=25^\circ\text{C}$
Parameter: V_{GS}

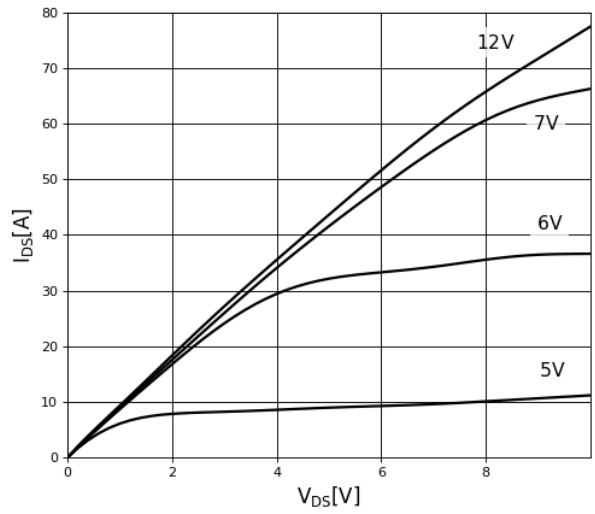

Figure 2. Typical Output Characteristics $T_J=150^\circ\text{C}$
Parameter: V_{GS}

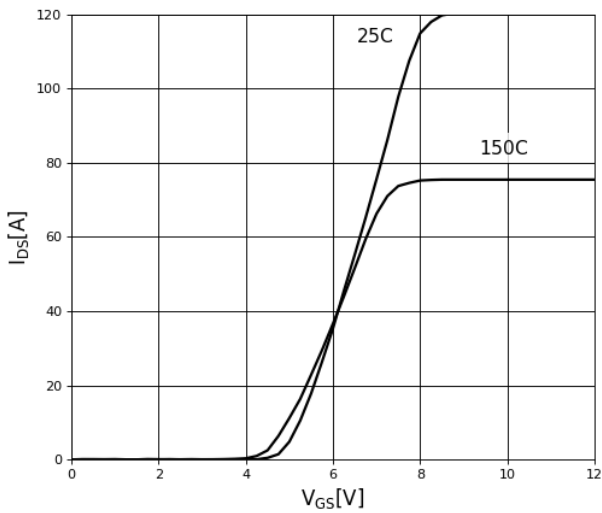

Figure 3. Typical Transfer Characteristics
 $V_{DS}=10\text{V}$, parameter: T_J

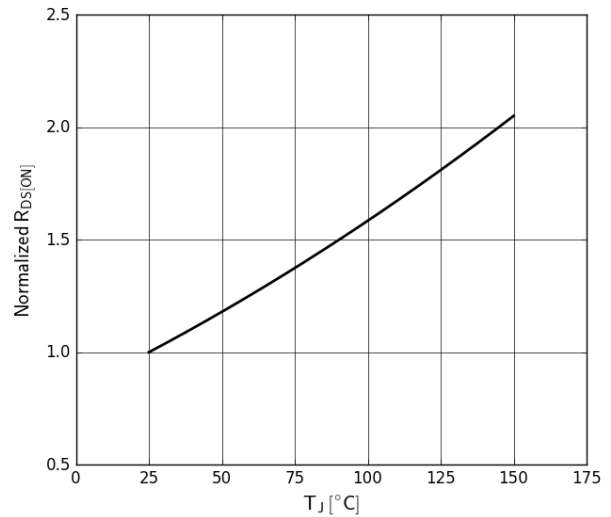

Figure 4. Normalized On-resistance
 $I_D=16\text{A}$, $V_{GS}=10\text{V}$

Typical Characteristics ($T_c=25^\circ\text{C}$ unless otherwise stated)

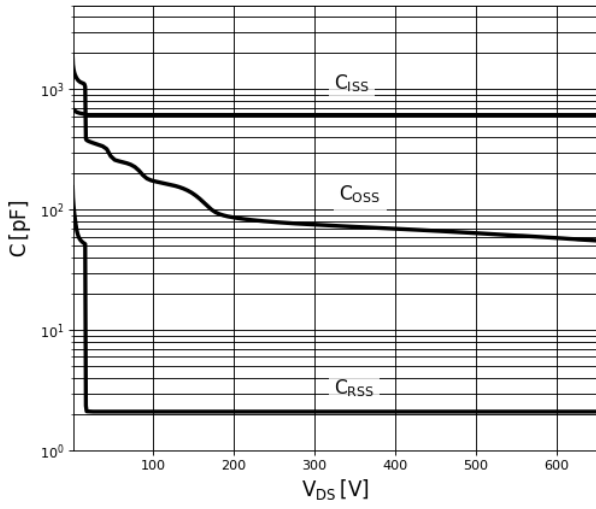

Figure 5. Typical Capacitance
 $V_{GS}=0V, f=1MHz$

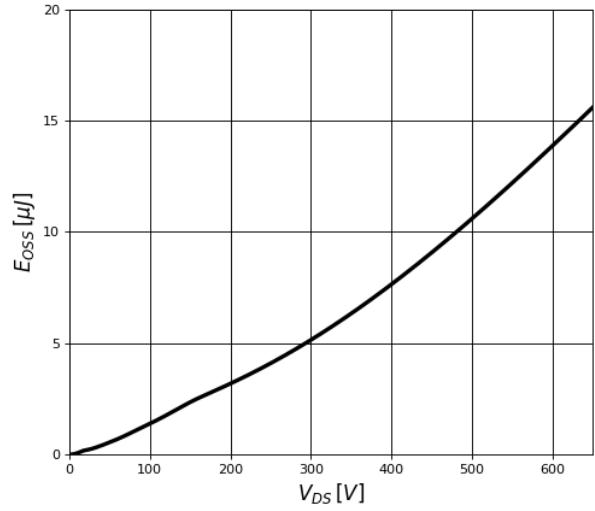

Figure 6. Typical C_{oss} Stored Energy

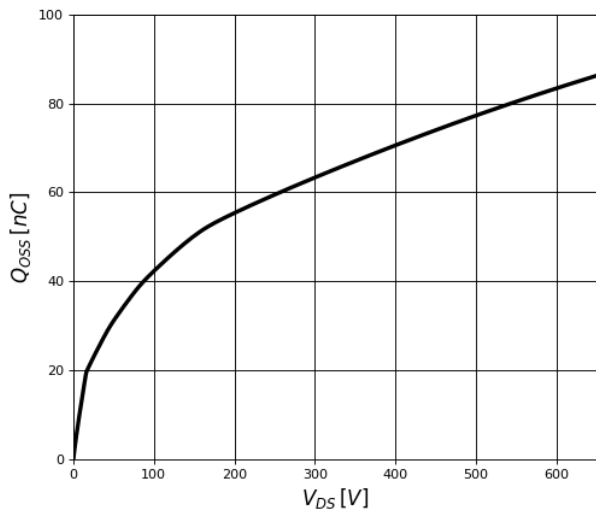

Figure 7. Typical Q_{oss}

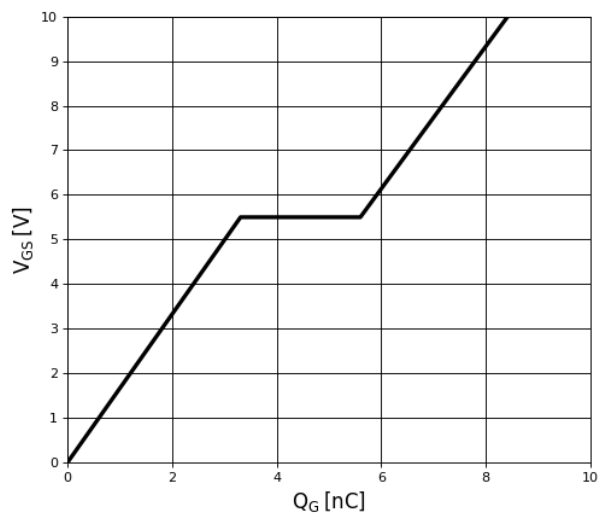

Figure 8. Typical Gate Charge
 $I_{DS}=16A, V_{DS}=400V$

Typical Characteristics ($T_c=25^\circ\text{C}$ unless otherwise stated)

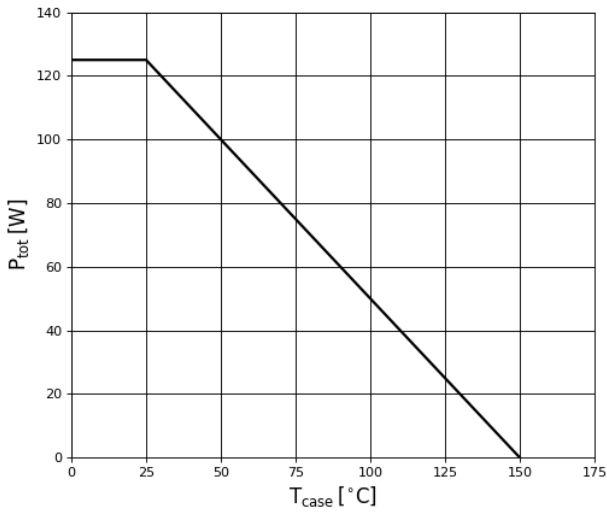

Figure 9. Power Dissipation

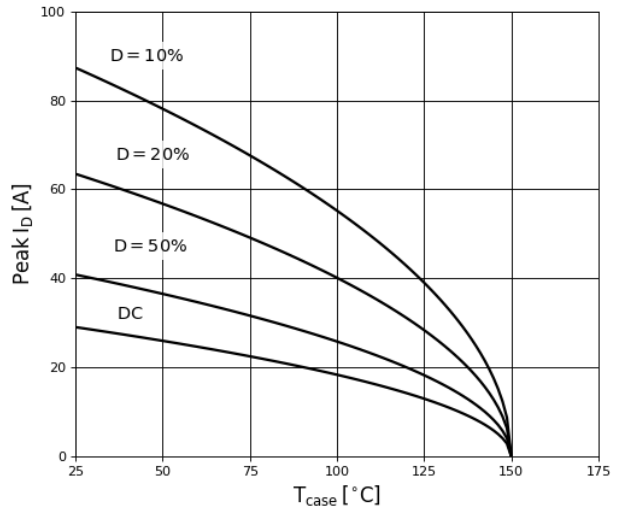

Figure 10. Current Derating

Pulse width $\leq 10\mu\text{s}$, $V_{GS} \geq 10\text{V}$

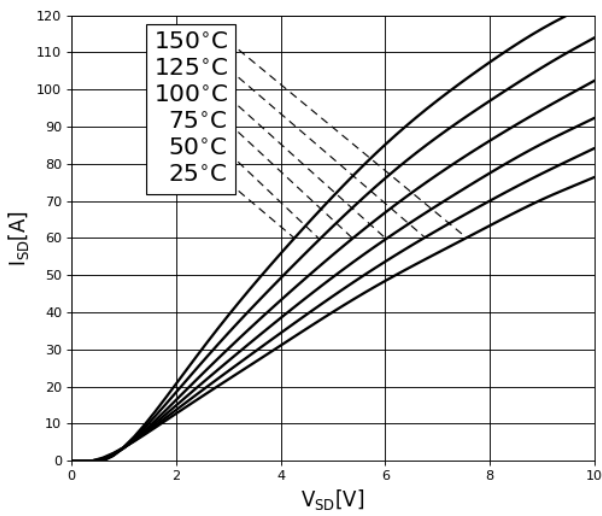

Figure 11. Forward Characteristics of Rev. Diode

$I_S=f(V_{SD})$, parameter: T_J

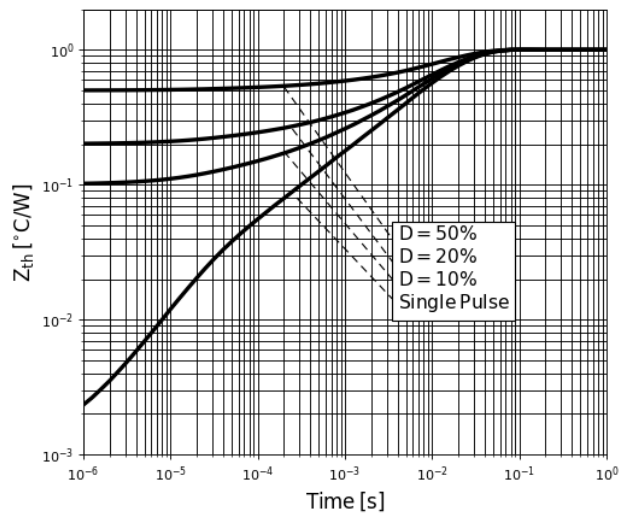

Figure 12. Transient Thermal Resistance

Typical Characteristics ($T_c=25^\circ\text{C}$ unless otherwise stated)

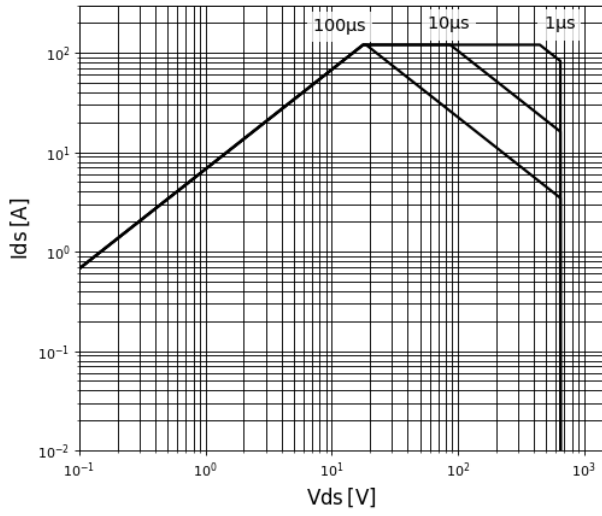

Figure 13. Safe Operating Area $T_c=25^\circ\text{C}$

Test Circuits and Waveforms

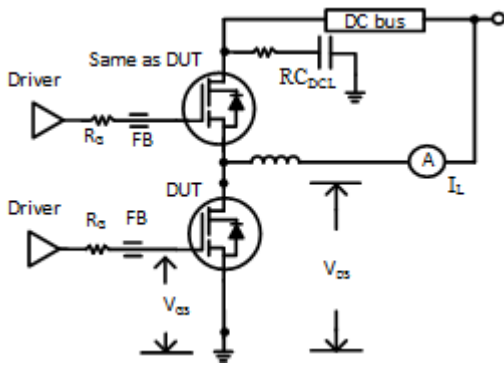

Figure 14. Switching Time Test Circuit

(see circuit implementation on page 3 for methods to ensure clean switching)

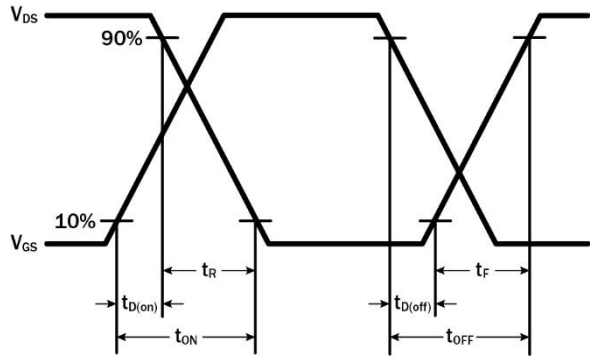

Figure 15. Switching Time Waveform

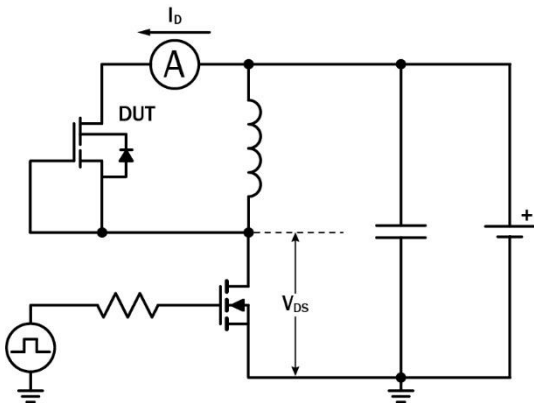

Figure 16. Diode Characteristics Test Circuit

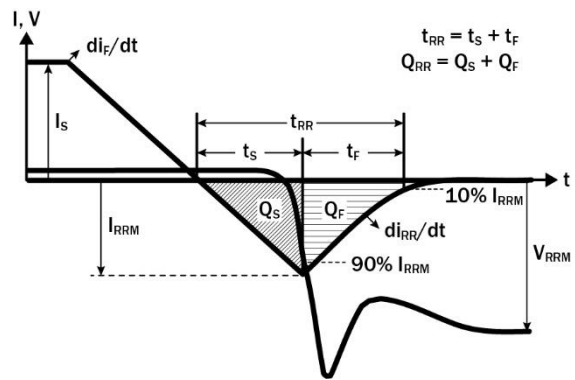

Figure 17. Diode Recovery Waveform

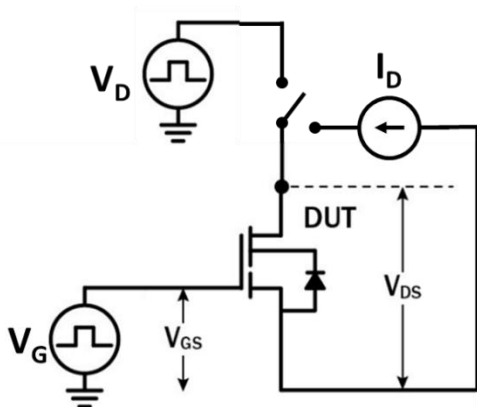

Figure 18. Dynamic RDS(on)eff Test Circuit

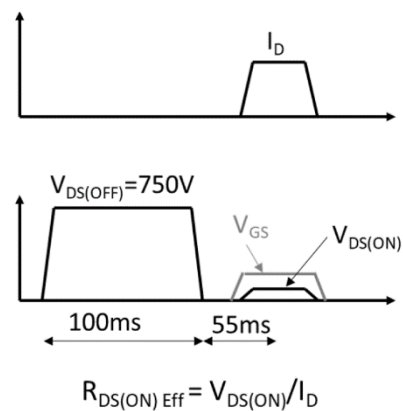

Figure 19. Dynamic RDS(on)eff Waveform

Design Considerations

The fast switching of GaN devices reduces current-voltage crossover losses and enables high frequency operation while simultaneously achieving high efficiency. However, taking full advantage of the fast switching characteristics of GaN switches requires adherence to specific PCB layout guidelines and probing techniques.

Before evaluating Renesas GaN devices, see application note [Printed Circuit Board Layout and Probing for GaN Power Switches](#). The table below provides some practical rules that should be followed during the evaluation.

When Evaluating Renesas GaN Devices:

DO	DO NOT
Minimize circuit inductance by keeping traces short, both in the drive and power loop	Twist the pins of TO-220 or TO-247 to accommodate GDS board layout
Minimize lead length of TO-220 and TO-247 package when mounting to the PCB	Use long traces in drive circuit, long lead length of the devices
Use shortest sense loop for probing; attach the probe and its ground connection directly to the test points	Use differential mode probe or probe ground clip with long wire
See Printed Circuit Board Layout and Probing	

GaN Design Resources

The complete technical library of GaN design tools can be found at [Renesasusa.com/design](https://www.renesas.com/design):

- Reference designs
- Evaluation kits
- Application notes
- Design guides
- Simulation models
- Technical papers and presentations

