

**Brief Description**

The ZLED7002 toggle (side-step) dual-channel LED driver is one of our ZLED family of LED control ICs. It operates in the lower DC voltage supply range of 2.7V to 5.5V. This unique LED driver is capable of controlling a MAIN channel and a SUB channel. Typically, only one of the two channels is active and the ZLED7002 toggles between the channels automatically in response to the voltage supply level and the related voltage at the UV (under-voltage protection) pin. A high-to-low transition of the power supply causes the output current to switch from the MAIN channel to the SUB channel if the UV pin voltage ( $V_{UV-PIN}$ ) is below the ZLED7002's under-voltage threshold ( $V_{UVTHRS}$ =1.17V, typical). A low-to-high transition switches the output current from the SUB channel to the MAIN channel if the UV pin voltage is 80mV (typical) above the under-voltage threshold.

The MAIN channel is a configurable constant current source driving the MAIN LED string with a maximum current draw of 250mA. The MAIN LED channel current is set by an external resistor (R3) connected to the Iset pin. Alternately, the SUB channel is activated when the ZLED7002's SUB pin is pulled to ground. Its current is determined by the forward voltage of the SUB LED and external components. The SUB channel can drive up to 100mA current through the LED channel when active.

The ZLED7002 enables voltage-level indicator applications and low-power battery-driven lighting applications that require switching to a lower-current LED channel when the supply is low, which extends the lighting life-time. Because the dropout voltage ( $V_{DP}$ ) is minimal (as low as 0.1V when the MAIN channel output current is ~200mA), the ZLED7002 is optimal for battery-powered applications. Capable of operating efficiently with DC voltage supplies ranging from 2.7V to 5.5V, it is ideal for small portable lighting applications.

The ZLED7002 can also reduce bill-of-material costs because very few external components are required for most applications, making it an optimal fit for small devices for which lighting lifetime is critical. Only four resistors, a diode, and a capacitor are needed for a typical basic application.

**Features**

- Automatic MAIN channel short-circuit protection switches the output current to the SUB channel if the MAIN LED is shorted
- Under-voltage power supply detection
- Over-temperature protection

**Benefits**

- Extends lighting life-time by switching to a lower-current LED channel when the supply is low
- 80mV (typical) hysteresis prevents unintended switching activation due to power supply ripple
- Ultra low quiescent current: 250µA typical
- Very few external components needed for operation

**Available Support**

- Evaluation Kit

**Physical Characteristics**

- Voltage supply: 2.7V to 5.5V DC
- Operating temperature: -25°C to 85°C
- Small SOP8 package

**ZLED7002 Typical Application Circuit**

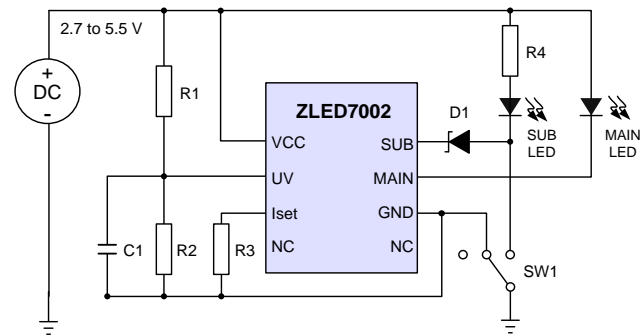

SOP8 Package Dimensions and Pin Assignments

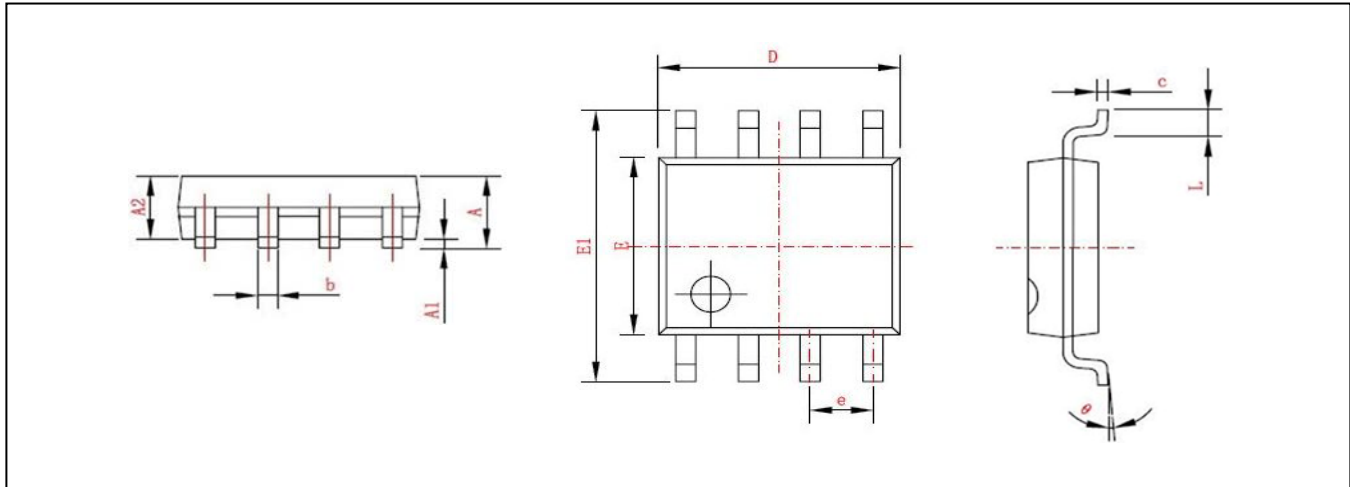

Symbol	Dimension (mm, except $\theta$ )	
	Min	Max
A	1.350	1.750
A1	0.100	0.250
A2	1.450 Typical	
b	0.350	0.490
c	0.178	0.250
D	4.800	5.000
E	3.800	4.000
E1	5.800	6.240
e	1.270 Typical	
L	0.400	1.270
$\theta$	0°	8°

Typical Applications

- ❖ Battery-driven LED lighting including
  - Helmet lighting
  - Bicycle lighting
  - Miner lamps
  - Pocket lights
- ❖ Voltage-level indicators
- ❖ General purpose low-voltage industrial and consumer LED applications

Ordering Information

Product Sales Code	Description	Package
ZLED7002ZI1R	ZLED7002 – Toggle (Side-Step) Dual-Channel LED Driver	SOP8 (Tape & Reel)
ZLED7002KIT-E1	ZLED7002 Evaluation Kit	Kit

## Contents

1	IC Characteristics .....	4
1.1.	Absolute Maximum Ratings .....	4
1.2.	Operating Conditions .....	4
1.3.	Electrical Parameters .....	4
1.4.	Typical Performance Graphs .....	5
2	Circuit Description .....	6
2.1.	ZLED7002 Overview .....	6
2.2.	Under-Voltage Threshold .....	7
2.3.	Main LED Current .....	7
2.4.	Sub LED Current .....	7
2.5.	ZLED7002 Protection Features .....	8
2.5.1.	Over-Temperature Protection .....	8
2.5.2.	Main LED Short-Circuit Protection .....	8
3	Application Circuit Design .....	9
3.1.	Applications .....	9
3.2.	Application Circuit Layout Requirements .....	9
4	ESD Protection .....	10
5	Pin Configuration and Package .....	10
6	Ordering Information .....	12
7	Document Revision History .....	12

## List of Figures

Figure 1.1	Iset Pin Voltage versus Temperature (+10°C to 100°C) .....	5
Figure 1.2	Main LED Current versus Power Supply (4V to 5.4V DC) .....	6
Figure 3.1	Basic ZLED7002 Application Circuit .....	9
Figure 5.1	ZLED7002 Pin Configuration .....	10
Figure 5.2	SOP8 Package Drawing .....	11

## List of Tables

Table 5.1	ZLED7002 Pin Descriptions and Connection Requirements—SOP8 Package .....	10
Table 5.2	SOP8 Package Dimensions .....	11

# 1 IC Characteristics

## 1.1. Absolute Maximum Ratings

No.	PARAMETER	SYMBOL	CONDITIONS	MIN	TYP	MAX	UNIT
1.1.1	Input voltage	$V_{CC}$		-0.3		6.5	V
1.1.2	Iset pin voltage	$V_{ISET}$		-0.3		6.5	V
1.1.3	UV pin voltage	$V_{UV-PIN}$		-0.3		6.5	V
1.1.4	MAIN pin voltage	$V_{MAIN}$		-0.3		6.5	V
1.1.5	SUB pin voltage	$V_{SUB}$		-0.3		6.5	V
1.1.6	MAIN pin current	$I_{MAIN\_ABS}$				500	mA
1.1.7	SUB pin current	$I_{SUB\_ABS}$				300	mA
1.1.8	ESD performance	$P_{tot}$	Human Body Model	$\pm 4$			kV
1.1.9	Junction temperature	$T_J$				150	°C
1.1.10	Storage temperature	$T_S$		-60		150	°C

## 1.2. Operating Conditions

No.	PARAMETER	SYMBOL	CONDITIONS	MIN	TYP	MAX	UNIT
1.2.1	Operating temperature	$T_{amb}$		-25		+85	°C
1.2.2	Input voltage	$V_{CC}$		2.7		5.5	V

## 1.3. Electrical Parameters

Except as noted, conditions for the following specifications are  $T_{amb} = -25^{\circ}\text{C}$  to  $+85^{\circ}\text{C}$  ( $25^{\circ}\text{C}$  typical);  $V_{CC} = 2.7\text{V}$  to  $5.5\text{V}$ .

Production testing of the chip is performed at  $25^{\circ}\text{C}$ ;  $V_{CC}=3.6\text{V}$ , unless otherwise stated. Functional operation of the chip and specified parameters at other temperatures are guaranteed by design, characterization, and process control.

No.	PARAMETER	SYMBOL	CONDITIONS	MIN	TYP	MAX	UNIT
1.3.1	Quiescent current	$I_{CC}$	$2.7 \leq V_{CC} \leq 5.5$ ; $1.4 < V_{UV-PIN} < 5.5$ ; no load		250	320	$\mu\text{A}$
1.3.2	$I_{MAIN}$ to $I_{ISET}$ ratio	--	$V_{CC} = 4.2\text{V}$ , $R_3 = 30\text{K}\Omega$		8000		
1.3.3	Iset pin voltage	$V_{ISET}$			1.2		V
1.3.4	Main LED current accuracy	--	$V_{CC} = 2.7\text{V}$ ; $V_{MAIN} = 0.5\text{V}$		$\pm 5$		%
1.3.5	Dropout voltage – MAIN channel current source	$V_{DP}$	$I_{out}=204\text{mA}$ , $R_{set}=47\text{K}$			0.2	V
1.3.6	“ON” resistance – SUB channel	$R_{SUB}$	$2.7\text{V} \leq V_{CC} \leq 5.5\text{V}$			2.0	$\Omega$
1.3.7	UV pin under-voltage threshold	$V_{UVTHRSH}$	Switches from MAIN LED to SUB LED if $V_{UV-PIN}$ transitions from high to low voltage and $V_{UV-PIN}$ is lower than $V_{UVTHRSH}$ .	1.13	1.17	1.21	V

No.	PARAMETER	SYMBOL	CONDITIONS	MIN	TYP	MAX	UNIT
1.3.8	UV pin comparator hysteresis (upper threshold – under-voltage threshold)	$V_{UVHYS}$	Switches from SUB LED to MAIN LED if $V_{UV-PIN}$ transitions from low voltage to high voltage and $V_{UV-PIN}$ is higher than $V_{UVTHRSH} + V_{UVHYS}$ (the upper threshold).		80		mV
1.3.9	Thermal protection threshold	$T_{SD}$			160		°C
1.3.10	Junction-to-ambient temperature	$R_{\theta JA}$			128		°C/W
1.3.11	MAIN pin current	$I_{MAIN}$			250mA		mA
1.3.12	SUB pin current	$I_{SUB}$			100mA		mA

### 1.4. Typical Performance Graphs

Figure 1.1 Iset Pin Voltage versus Temperature (+10°C to 100°C)

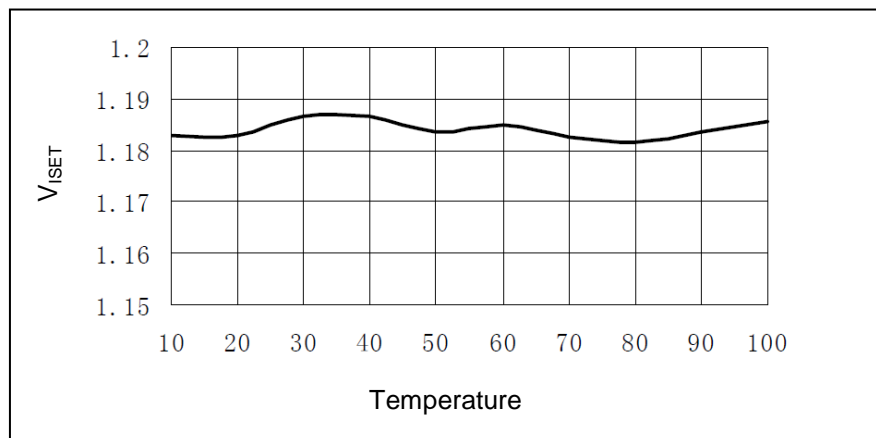

**Figure 1.2 Main LED Current versus Power Supply (4V to 5.4V DC)**

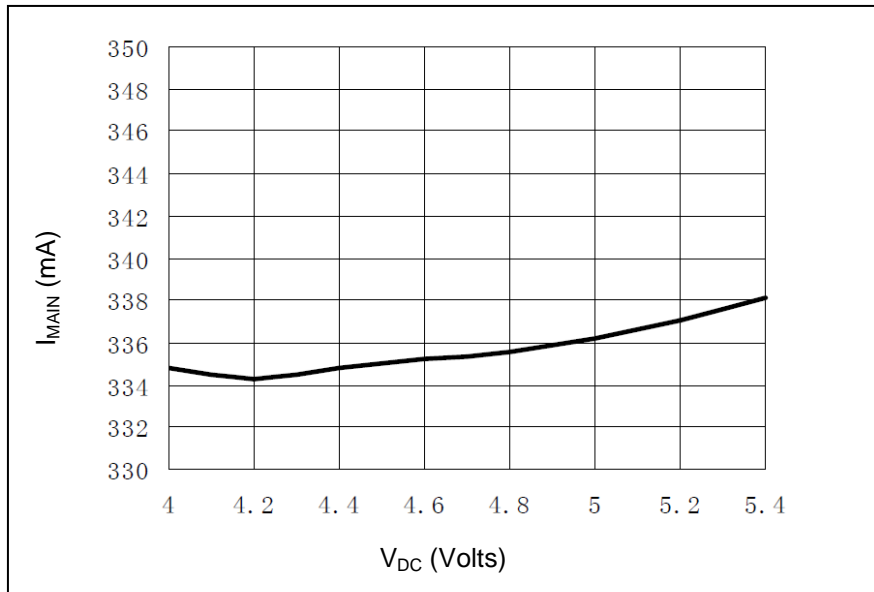

## 2 Circuit Description

### 2.1. ZLED7002 Overview

The ZLED7002 is an LED driver for two channels designated as the MAIN channel and the SUB channel. Typically, only one of the channels is on and the other is off. External resistors R1 and R2 connected to UV pin form a voltage divider across the power supply. When the power supply voltage has risen high enough to create a voltage at the UV pin that is above a set threshold, the MAIN LED channel is activated and the SUB channel is off. If the supply falls and the resulting voltage at the UV pin is below the threshold, the SUB channel becomes active and the MAIN channel is turned off.

When the MAIN channel is active, the ZLED7002 provides a constant current source for driving the MAIN LED channel. Its current level is set by an external resistor (R3) between the Iset and GND pins (see section 2.3). When the SUB LED channel is active, its current is determined by external components (see section 2.4) and the ZLED7002 pulls the SUB pin to ground.

Refer to the application circuit in Figure 3.1 for the location of the components referred to in the following sections.

## 2.2. Under-Voltage Threshold

The ZLED7002's UV pin enables under-voltage detection. When a high-to-low transition occurs on the power supply voltage and the voltage at the UV pin falls below the under-voltage threshold (typically 1.17V), the ZLED7002 automatically turns off the MAIN LED channel and activates the SUB channel. There is an 80mV hysteresis for the under-voltage threshold to prevent unintended activation due to power supply ripple. When a low-to-high transition occurs on the power supply voltage, the SUB channel is turned off and the MAIN channel is activated if the UV pin voltage is 80mV (typical) above the under-voltage threshold.

The voltage at the UV pin ( $V_{UV-PIN}$ ) is determined by the ratio of the external resistors R1 and R2 (see Figure 3.1), which connect to the UV pin to form a voltage divider across the power supply.  $V_{UV-PIN}$  can be calculated with equation (1):

$$V_{UV-PIN} = V_{CC} \left( \frac{R2}{R1 + R2} \right) \quad (1)$$

If the values for R1 and R2 are low, high current will flow through them resulting in lower system efficiency. Typical values for R1 and R2 are in the magnitude of  $10^5$ ; e.g., 51k $\Omega$ . For design purposes, it is helpful to select the value for R2 first and then compute R1 as needed to achieve the target ratio.

For applications using a lithium battery, which typically maintains ~3.7V during its discharge stage, setting  $V_{UV-PIN}$  to 3.4V is recommended.

## 2.3. Main LED Current

The R3 resistor connected between the Iset and GND pins determines the level of the constant current through the MAIN LED channel, which is typically 8000 times the current of the Iset pin. The voltage at the Iset pin is a constant 1.2V, which is unaffected by environmental temperature and any power supply voltage changes as shown in Figure 1.1 and Figure 1.2.

The MAIN LED current flows through the MAIN pin to ground, so voltage dropout is minimal (as low as 0.1V when the MAIN channel current is 200mA).

Note: System efficiency is reduced if the power supply voltage is larger than the MAIN LED's voltage. In this case, the additional voltage is added to the MAIN pin voltage.

The MAIN LED channel current ( $I_{MAIN}$ ) is calculated via equation (2):

$$I_{MAIN} = 8000 \left( \frac{V_{ISET}}{R3} \right) \quad (2)$$

## 2.4. Sub LED Current

The SUB LED channel current is determined by the external R4 resistor in series with the connected SUB LED string, the SUB LED forward voltage, and the voltage drop across the D1 Zener diode connected from the cathode of the SUB LED to the SUB pin. When the SUB channel is active, its current flows through the SUB pin to ground.

The SUB LED channel current ( $I_{SUB}$ ) is calculated via equation (3):

$$I_{SUB} = \left( \frac{V_{CC} - V_{FSUB-LED} - V_{FD1}}{R4} \right) \quad (3)$$

Where

$V_{FSUB-LED}$  = The forward voltage of the SUB LED

$V_{FD1}$  = The forward voltage of Zener diode D1, which should be as small as possible

## **2.5. ZLED7002 Protection Features**

### **2.5.1. Over-Temperature Protection**

The ZLED7002 includes protection from damage due to over-temperature conditions. The ZLED7002 automatically turns off if its temperature is  $\geq 160^{\circ}\text{C}$  (typical). If the temperature returns to  $\leq 140^{\circ}\text{C}$ , the ZLED7002 turns on and continues normal operation.

### **2.5.2. Main LED Short-Circuit Protection**

The ZLED7002 will detect a short-circuit on the MAIN LED. In this case, the ZLED7002 automatically turns off the MAIN LED channel and activates the SUB LED channel.



### 3 Application Circuit Design

#### 3.1. Applications

The ZLED7002 is designed for small battery-powered lighting life-time critical applications. Capable of operating efficiently with DC voltage supplies ranging from 2.7V to 5.5V, it is ideal for small portable lighting applications. Typical applications include helmet lighting, head/tail lights for bicycles, miner lamps, pocket lights, and various other general purpose low-voltage industrial and consumer LED applications.

**Figure 3.1 Basic ZLED7002 Application Circuit**

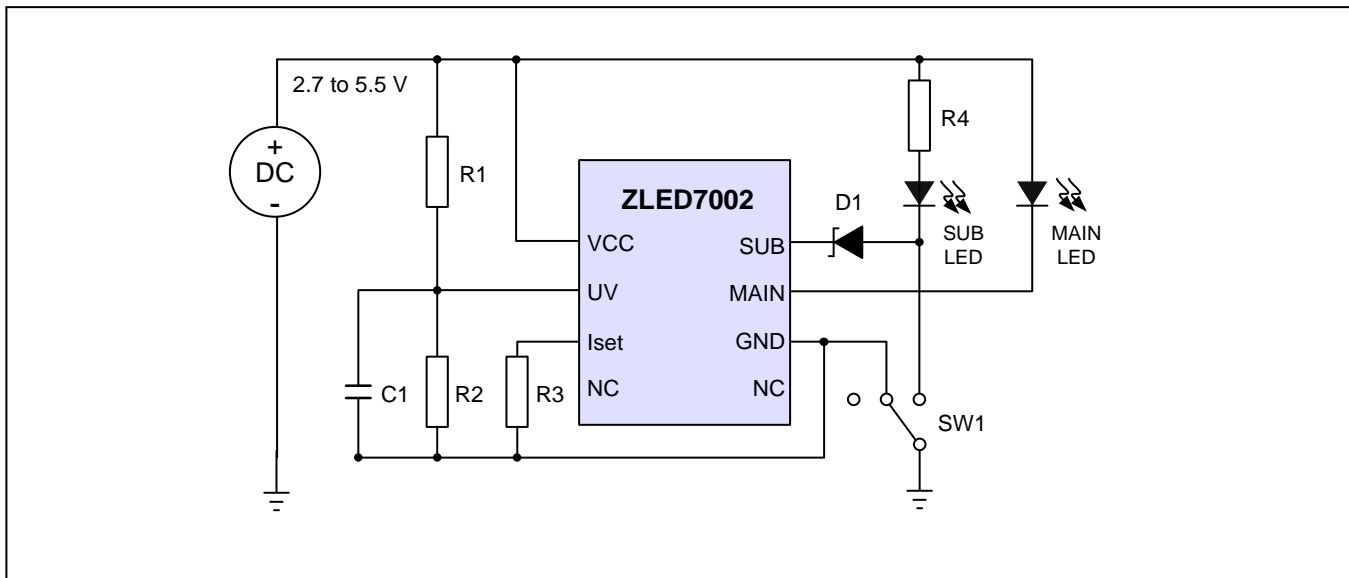

#### 3.2. Application Circuit Layout Requirements

The following guidelines are strongly recommended when laying out application circuits:

- Use a 0.1µf capacitor connected between the UV pin and ground to minimize noise picked up on the UV pin. Place the capacitor close to the UV pin.
- If the application includes a switch as shown in Figure 3.1, locate it at the lowest voltage point to avoid sparks when switching.
- Use traces that are as short and wide as possible for any traces leading to actual ground that occur between the GND pin and Iset pin. This improves accuracy for the MAIN LED current and the under-voltage threshold.

Also see Table 5.1 for connection requirements.

## 4 ESD Protection

All pins have an ESD protection of  $\geq \pm 4000V$  according the Human Body Model (HBM). The ESD test follows the Human Body Model with 1.5 k $\Omega$ /100 pF based on MIL 883-G, Method 3015.7.

## 5 Pin Configuration and Package

**Figure 5.1** ZLED7002 Pin Configuration

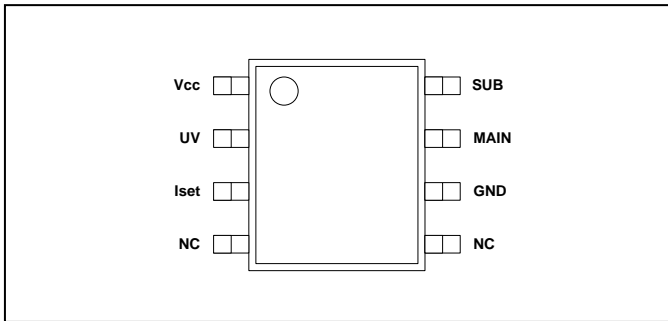

**Table 5.1** ZLED7002 Pin Descriptions and Connection Requirements—SOP8 Package

Pin	No.	Description (Also see section 3.2 for layout guidelines)
V <sub>CC</sub>	1	Power supply (2.7V to 5.5V).
UV	2	Under-voltage detection input.
I <sub>SET</sub>	3	Input for external resistor that sets the current for the MAIN LED channel.
NC	4	No connection.
NC	5	No connection.
GND	6	Connect to ground.
MAIN	7	MAIN channel constant current source. Connect to cathode of MAIN LED.
SUB	8	SUB channel current sink. Connect to cathode of D1 (Zener diode) connected to cathode of SUB LED.

Figure 5.2 SOP8 Package Drawing

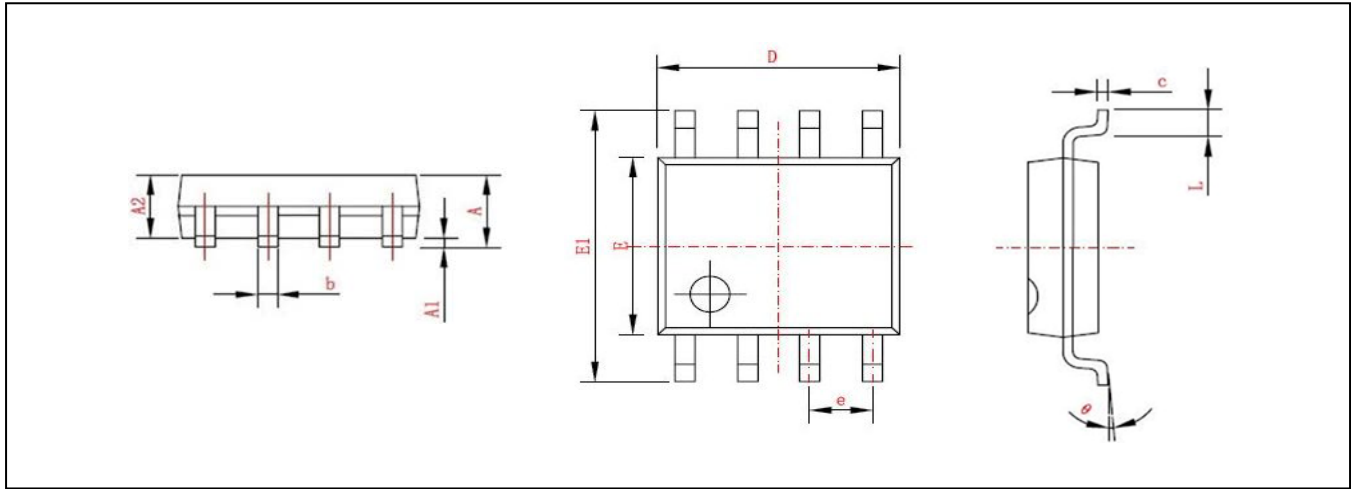

Table 5.2 SOP8 Package Dimensions

Symbol	Dimension (mm)		Symbol	Dimension (mm, except $\theta$ )	
	Min	Max		Min	Max
A	1.350	1.750	E	3.800	4.000
A1	0.100	0.250	E1	5.800	6.240
A2	1.450 Typical		e	1.270 Typical	
b	0.350	0.490	L	0.400	1.270
c	0.178	0.250	$\theta$	0°	8°
D	4.800	5.000			

## 6 Ordering Information

Product Sales Code	Description	Package
ZLED7002ZI1R	ZLED7002 – Toggle (Side-Step) Dual-Channel LED Driver	SOP8 (Tape & Reel)
ZLED7002KIT-E1	ZLED7002 Evaluation Kit	Kit

## 7 Document Revision History

Revision	Date	Description
1.0	15 July, 2011	First issue.
	April 20, 2016	Changed to IDT branding.

## IMPORTANT NOTICE AND DISCLAIMER

RENESAS ELECTRONICS CORPORATION AND ITS SUBSIDIARIES (“RENESAS”) PROVIDES TECHNICAL SPECIFICATIONS AND RELIABILITY DATA (INCLUDING DATASHEETS), DESIGN RESOURCES (INCLUDING REFERENCE DESIGNS), APPLICATION OR OTHER DESIGN ADVICE, WEB TOOLS, SAFETY INFORMATION, AND OTHER RESOURCES “AS IS” AND WITH ALL FAULTS, AND DISCLAIMS ALL WARRANTIES, EXPRESS OR IMPLIED, INCLUDING, WITHOUT LIMITATION, ANY IMPLIED WARRANTIES OF MERCHANTABILITY, FITNESS FOR A PARTICULAR PURPOSE, OR NON-INFRINGEMENT OF THIRD-PARTY INTELLECTUAL PROPERTY RIGHTS.

These resources are intended for developers who are designing with Renesas products. You are solely responsible for (1) selecting the appropriate products for your application, (2) designing, validating, and testing your application, and (3) ensuring your application meets applicable standards, and any other safety, security, or other requirements. These resources are subject to change without notice. Renesas grants you permission to use these resources only to develop an application that uses Renesas products. Other reproduction or use of these resources is strictly prohibited. No license is granted to any other Renesas intellectual property or to any third-party intellectual property. Renesas disclaims responsibility for, and you will fully indemnify Renesas and its representatives against, any claims, damages, costs, losses, or liabilities arising from your use of these resources. Renesas' products are provided only subject to Renesas' Terms and Conditions of Sale or other applicable terms agreed to in writing. No use of any Renesas resources expands or otherwise alters any applicable warranties or warranty disclaimers for these products.

(Disclaimer Rev.1.01)

### Corporate Headquarters

TOYOSU FORESIA, 3-2-24 Toyosu,  
Koto-ku, Tokyo 135-0061, Japan  
[www.renesas.com](http://www.renesas.com)

### Trademarks

Renesas and the Renesas logo are trademarks of Renesas Electronics Corporation. All trademarks and registered trademarks are the property of their respective owners.

### Contact Information

For further information on a product, technology, the most up-to-date version of a document, or your nearest sales office, please visit [www.renesas.com/contact-us/](http://www.renesas.com/contact-us/).