

Brief Description

The ZLED7015, one of our ZLED family of LED control ICs, is a constant current boost converter with an internal high-power 35V switch. It is optimal for driving multiple white LEDs connected in series so that the LED current is uniform for better brightness and color control. It can also drive devices that require a constant voltage and is capable of operating efficiently with voltage supplies ranging from 6VDC to 30VDC. It is ideal for diverse lighting applications requiring low supply voltages such as SELV applications. Typically, smaller, less expensive external components can be used since the ZLED7015 switches at 1.0MHz (typical).

The ZLED7015 output current is adjustable via an external current sense resistor R_S connected from the FB pin to ground.

The ZLED7015 improves efficiency and minimizes power losses in the current setting resistor R_S by use of an internal 0.3V feedback reference voltage.

Dimming can be controlled using a pulse-width modulation (PWM) waveform or a DC voltage applied to the FB pin.

The ZLED7015 provides a “soft-start” function to prevent excessive in-rush current on start-up and ensures a controlled rise of the output voltage.

Over-voltage protection is adjustable via external resistors R_1 and R_2 .

Features

- Integrated 35V power switch
- Wide input range: 6VDC to 30VDC
- Over-temperature protection
- Over-voltage (open LED string) protection adjusted via external resistor divider
- Under-voltage lockout ensures reliable circuit operation
- Control of output current during start-up via internal “soft-start”
- Switching frequency: 1.0MHz
- Single pin on/off or brightness control via PWM, microcontroller, or DC voltage control signal input
- MSOP-10 package

Benefits

- High efficiency: up to 95% efficiency
- Few small, low-profile components needed for operation
- Small form-factor package

Available Support

- Evaluation Kit

Physical Characteristics

- Operating temperature: -40°C to 85°C
- RoHS-compliant

ZLED7015 Typical Application Circuit

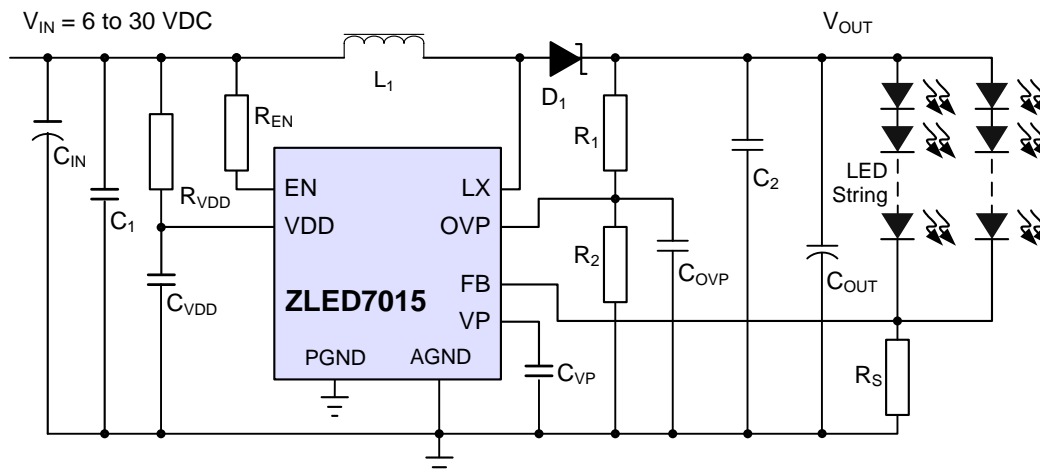

ZLED7015 Block Diagram

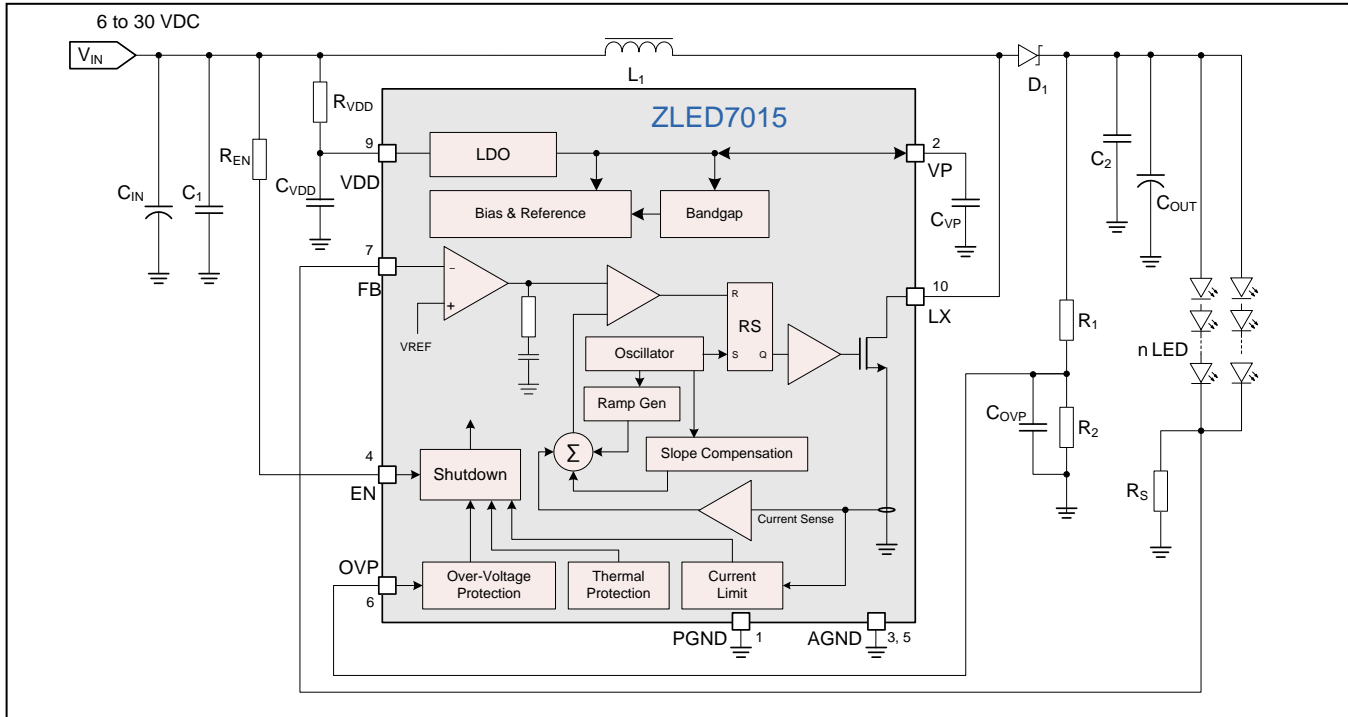

Typical Applications

- ❖ Low-Voltage Retro-fit Lighting
- ❖ MR16 Lights
- ❖ SELV Lighting
- ❖ Signage and Outdoor Lighting
- ❖ Architectural/Building Lighting
- ❖ Replacement Tubes
- ❖ LED Backlighting
- ❖ General Purpose Low-Voltage Industrial and Consumer Applications

Ordering Information

Product Sales Code	Description	Package
ZLED7015ZI1R	ZLED7015 – 1.0MHz Boost Converter with Internal 35V Switch	MSOP-10 (Tape & Reel)
ZLED7015KIT-E1	ZLED7015-E1 Evaluation Board, 1 ZLED-PCB10, and 5 ZLED7015 ICs	Kit

Contents

1	IC Characteristics	5
1.1	Absolute Maximum Ratings	5
1.2	Operating Conditions	5
1.3	Electrical Parameters.....	6
1.4	Typical Operating Characteristics	7
1.5	Characteristic Waveforms.....	10
2	Circuit Description	12
2.1	EN Pin, VP Pin, and Soft-Start Function	12
2.2	Output Current Control.....	12
2.2.1	Output Current and R_S	12
2.2.2	Dimming via External DC Voltage Control.....	13
2.2.3	Dimming via PWM Control.....	14
2.2.4	Microcontroller LED Control.....	15
2.2.5	Constant Voltage Application.....	15
3	Application Circuit Design	17
3.1	External Component – R_S	17
3.2	External Component – Inductor L_1	17
3.3	External Components – Input Decoupling Capacitors C_1 and C_{IN}	17
3.4	External Component –Output Capacitors C_2 and C_{OUT}	17
3.5	External Component – Diode D_1	17
3.6	Additional External Components.....	17
4	Operating Conditions.....	18
4.1	Under-Voltage Lockout.....	18
4.2	Over-Voltage Threshold and Open-Circuit Protection.....	18
4.3	Over-Temperature Protection	18
5	ESD/Latch-Up-Protection	19
6	Pin Configuration and Package	19
7	Layout Requirements	21
7.1	General Considerations and Ground Traces	21
7.2	Layout Considerations for C_1 , C_{IN} , C_2 and C_{OUT}	21
7.3	Layout Considerations for the EN Pin	21
7.4	Layout Considerations for the LX Pin, L_1 External Coil, and D_1 Diode.....	21
7.5	Layout Considerations for the External Current Sense Resistor (R_S)	21
7.6	Layout Considerations for C_{VP} and C_{VDD}	21
7.7	Layout Considerations for the Thermal Pad.....	21
8	Glossary of Terms.....	22
9	Ordering Information	22
10	Document Revision History	22

List of Figures

Figure 1.1	I_{OUT} vs. V_{IN} with $R_S = 0.42\Omega$	7
Figure 1.2	I_{OUT} vs. V_{IN} with $R_S = 0.88\Omega$	7
Figure 1.3	I_{OUT} vs. V_{OUT} with $R_S = 0.42\Omega$	7
Figure 1.4	I_{OUT} vs. V_{OUT} with $R_S = 0.88\Omega$	7
Figure 1.5	Efficiency vs. V_{IN} with $R_S = 0.42\Omega$	8
Figure 1.6	Efficiency vs. V_{IN} with $R_S = 0.88\Omega$	8
Figure 1.7	Efficiency vs. V_{OUT} with $R_S = 0.42\Omega$	9
Figure 1.8	Efficiency vs. V_{OUT} with $R_S = 0.88\Omega$	9
Figure 1.9	V_{FB} Reversion Voltage vs. V_{IN}	9
Figure 1.10	I_{OUT} vs. PWM Duty Cycle.....	9
Figure 1.11	V_{OUT} , V_{IN} , and I_{L1} during Soft Start.....	10
Figure 1.12	V_{OUT} , V_{LX} , and I_{OUT} during Typical Operation.....	11
Figure 1.13	V_{OUT} , V_{LX} , and I_{L1} when Over-Voltage Protection (OVP) Threshold is Exceeded.....	11
Figure 2.1	Typical Application Circuit.....	13
Figure 2.2	Example Circuit for Controlling Output Current via an External DC Control Voltage.....	13
Figure 2.3	Example Circuit for Controlling Output Current via a PWM Control Signal.....	14
Figure 2.4	Example Circuit for Constant Voltage Source Applications.....	16
Figure 6.1	ZLED7015 Pin Configuration—MSOP-10 Package.....	19
Figure 6.2	MSOP-10 Package Dimensions for the ZLED7015.....	20

List of Tables

Table 1.1	Absolute Maximum Ratings.....	5
Table 1.2	Operating Conditions.....	5
Table 1.3	Electrical Parameters.....	6
Table 6.1	Pin Description MSOP-10.....	19

1 IC Characteristics

Note: Exceeding the maximum ratings given in this section could cause operation failure and/or cause permanent damage to the ZLED7015. Exposure to these conditions for extended periods may affect device reliability.

1.1 Absolute Maximum Ratings

Table 1.1 Absolute Maximum Ratings

No.	PARAMETER	SYMBOL	CONDITIONS	MIN	TYP	MAX	UNIT
1.1.1	Supply voltage on VDD pin (also see specification 1.2.2)	V_{DD}		-0.3		40.0	V
1.1.2	LX pin output voltage	V_{LX}		-0.3		40.0	V
1.1.3	All other pins			-0.3		6.0	V
1.1.4	ESD Performance Human Body Model		High voltage pins: 1, 4, 5, 9, and 10			± 2.5	kV
			Low voltage pins: 2, 3, 6, 7, and 8			± 4	kV
1.1.5	Junction temperature	$T_{j\text{MAX}}$		-40		150	°C
1.1.6	Storage temperature	T_{ST}		-65		150	°C
1.1.7	Lead soldering temperature		10 seconds maximum			260	°C
1.1.8	Junction-to-ambient thermal resistance	$R_{\theta JA}$				60	°C/W

1.2 Operating Conditions

Table 1.2 Operating Conditions

No.	PARAMETER	SYMBOL	CONDITIONS	MIN	TYP	MAX	UNIT
1.2.1	Operating temperature	T_{OP}		-40		+85	°C
1.2.2	Supply voltage on VDD pin (also see absolute maximum specification 1.1.1)	V_{DD}		6		30	V

1.3 Electrical Parameters

Test conditions for the following specifications are $T_{amb} = 25^{\circ}\text{C}$ (typical) and $V_{DD} = 12\text{V}$, unless otherwise noted.

Production testing of the ZLED7015 is performed at 25°C unless otherwise stated. Functional operation of the ZLED7015 and specified parameters at other temperatures are guaranteed by design, characterization, and process control.

Table 1.3 Electrical Parameters

No.	PARAMETER	SYMBOL	CONDITIONS	MIN	TYP	MAX	UNIT
1.3.1	Supply current	I_{DD}	Continuous switching		2		mA
			Quiescent: no switching		1.1		mA
1.3.2	Shutdown current	I_{SD}	Shutdown: no switching; $V_{EN}=0\text{V}$		15		μA
1.3.3	LX switching frequency	f_{OCS}			1		MHz
1.3.4	Maximum duty cycle	D_{LX}			90		%
1.3.5	EN pin ON threshold voltage	V_{ENon}	Rising V_{EN}	1.4			V
1.3.6	EN pin OFF threshold voltage	V_{ENoff}	Falling V_{EN}			0.4	V
1.3.7	Internal feedback reference voltage	V_{FB}		0.285	0.3	0.315	V
1.3.8	Integrated switch ON resistance	R_{DSon}			0.8	1.2	Ω
1.3.9	Integrated switch current limit	$I_{SWlimit}$	Duty cycle = 90%	1.8	2.1	2.4	A
1.3.10	Integrated switch leakage current	I_{SWleak}	$V_{LX} = 40\text{V}$			1	μA
1.3.11	Internal regulator	V_P	$6\text{V} < V_{DD} < 30\text{V}$, $C_{VP} = 10\mu\text{F}$	4.5	5.0	5.5	V
1.3.12	Over-temperature protection (OTP) threshold	T_{OTP}			150		$^{\circ}\text{C}$
1.3.13	OTP threshold hysteresis	T_{OTP_HYS}			50		$^{\circ}\text{C}$
1.3.14	Under-voltage lock-out threshold (UVLO)	V_{UVLO}	Falling V_{DD}		2.9		V
1.3.15	UVLO hysteresis	V_{UVLO_HYS}			100		mV
1.3.16	Internal over-voltage threshold reference voltage	V_{OVP_TH}			0.9		V
1.3.17	Over-voltage protection threshold hysteresis	$V_{OVP_TH_HYS}$			10		mV

1.4 Typical Operating Characteristics

The curves are valid for the typical application circuit and $T_{amb} = 25^{\circ}\text{C}$ unless otherwise noted.

Figure 1.1 I_{OUT} vs. V_{IN} with $R_S = 0.42\Omega$

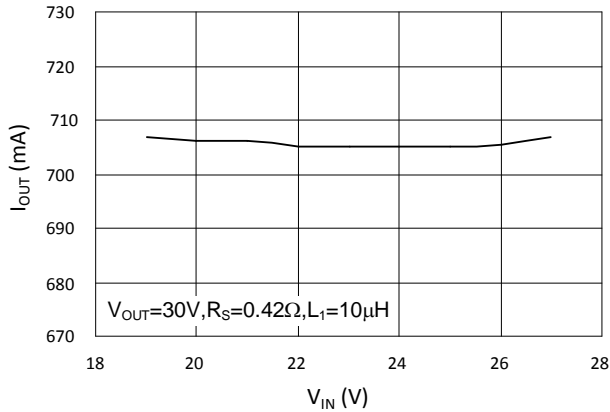

Figure 1.2 I_{OUT} vs. V_{IN} with $R_S = 0.88\Omega$

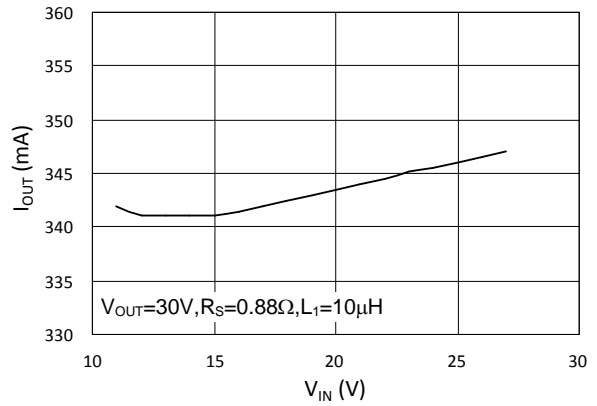

Figure 1.3 I_{OUT} vs. V_{OUT} with $R_S = 0.42\Omega$

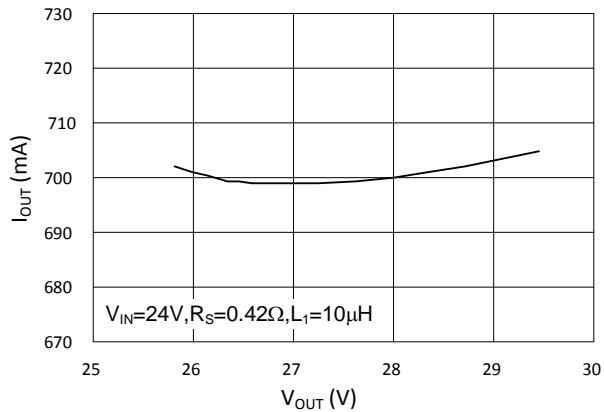

Figure 1.4 I_{OUT} vs. V_{OUT} with $R_S = 0.88\Omega$

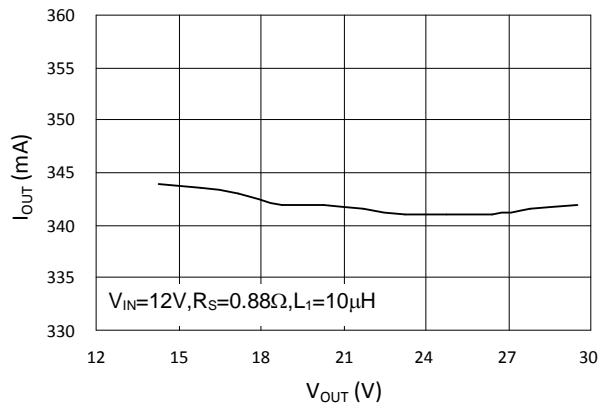

Figure 1.5 Efficiency vs. V_{IN} with $R_S = 0.42\Omega$

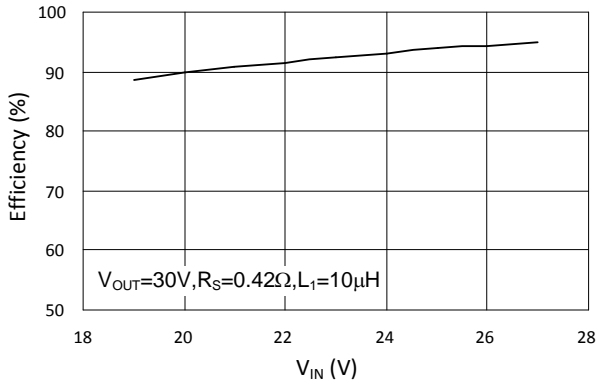

Figure 1.6 Efficiency vs. V_{IN} with $R_S = 0.88\Omega$

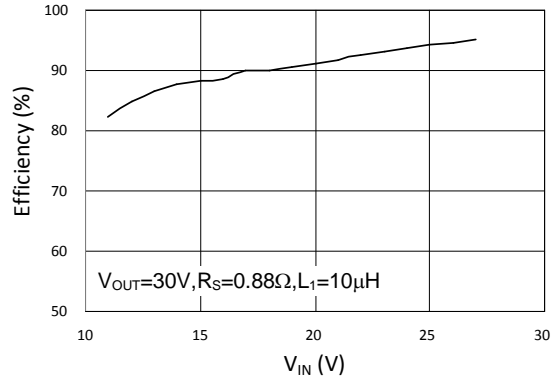

Figure 1.7 Efficiency vs. V_{OUT} with $R_S = 0.42\Omega$

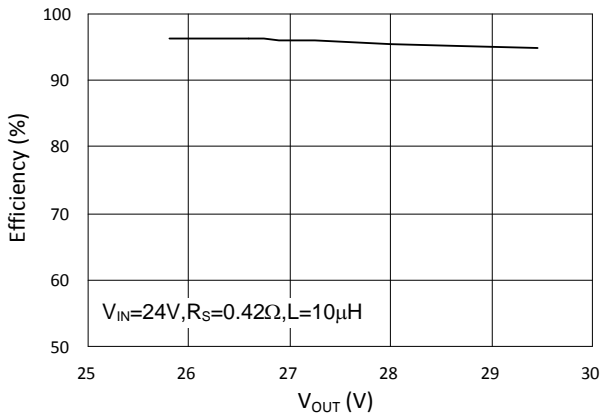

Figure 1.8 Efficiency vs. V_{OUT} with $R_S = 0.88\Omega$

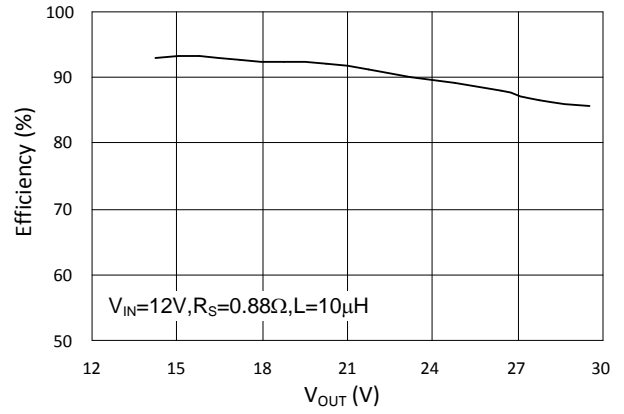

Figure 1.9 V_{FB} Reverence Voltage vs. V_{IN}

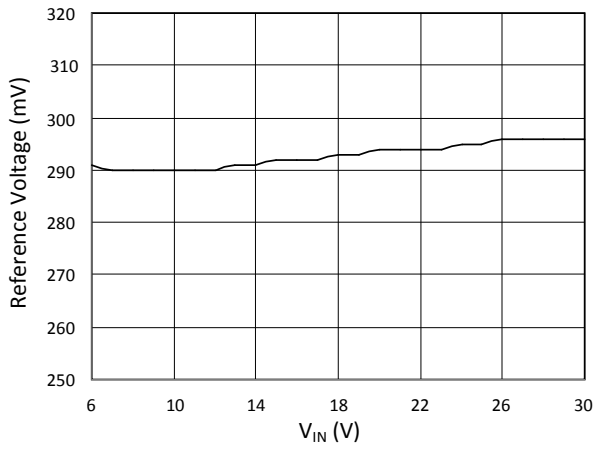
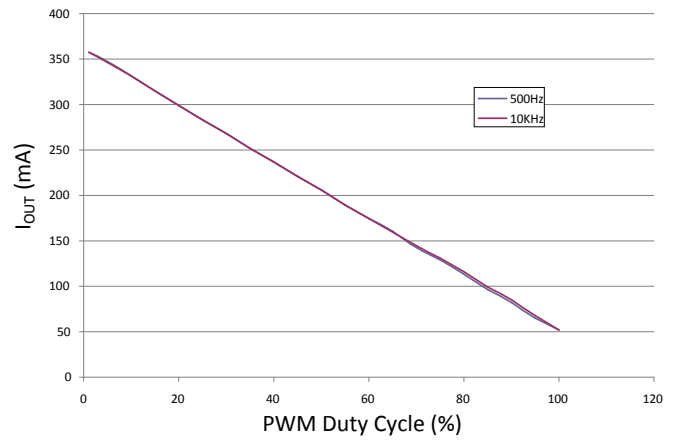

Figure 1.10 I_{OUT} vs. PWM Duty Cycle

(For details of PWM dimming, see section 2.2.3.)



1.5 Characteristic Waveforms

Figure 1.11 V_{OUT} , V_{IN} , and I_{L1} during Soft Start

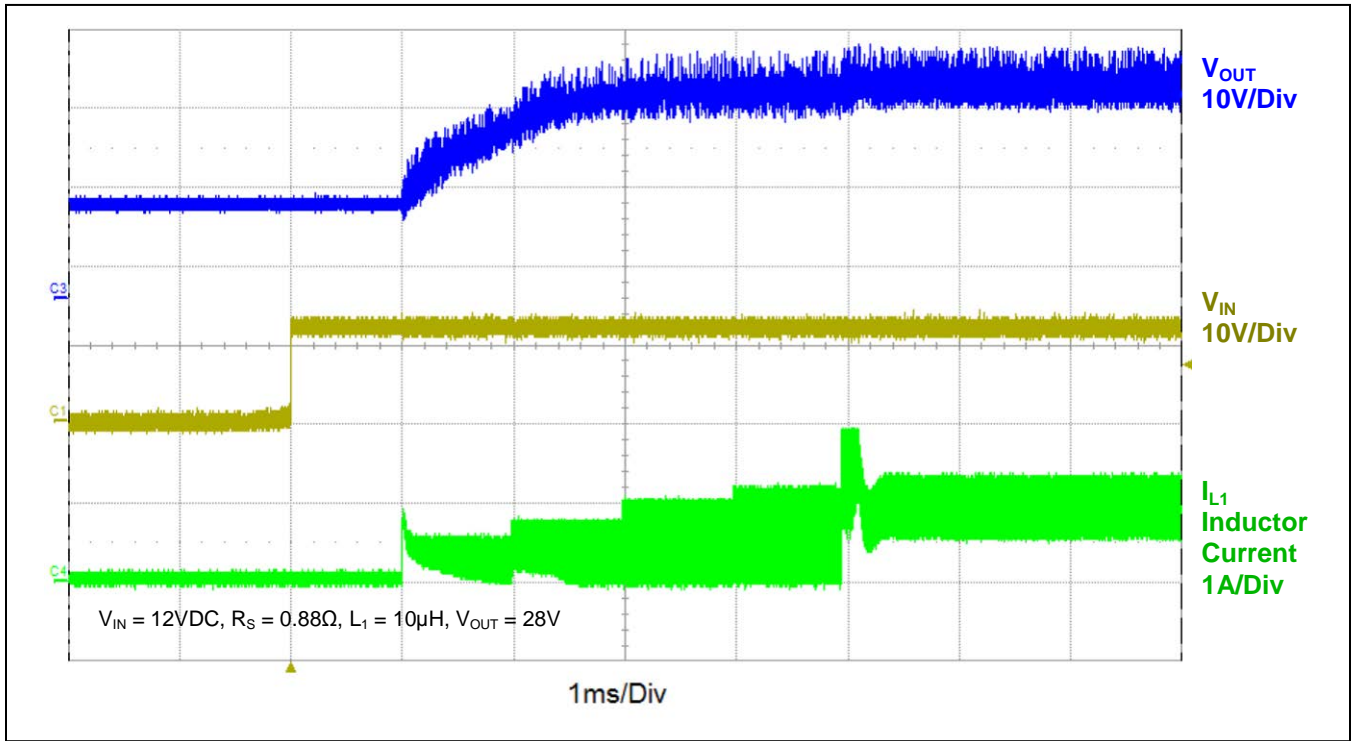

Figure 1.12 V_{OUT} , V_{LX} , and I_{OUT} during Typical Operation

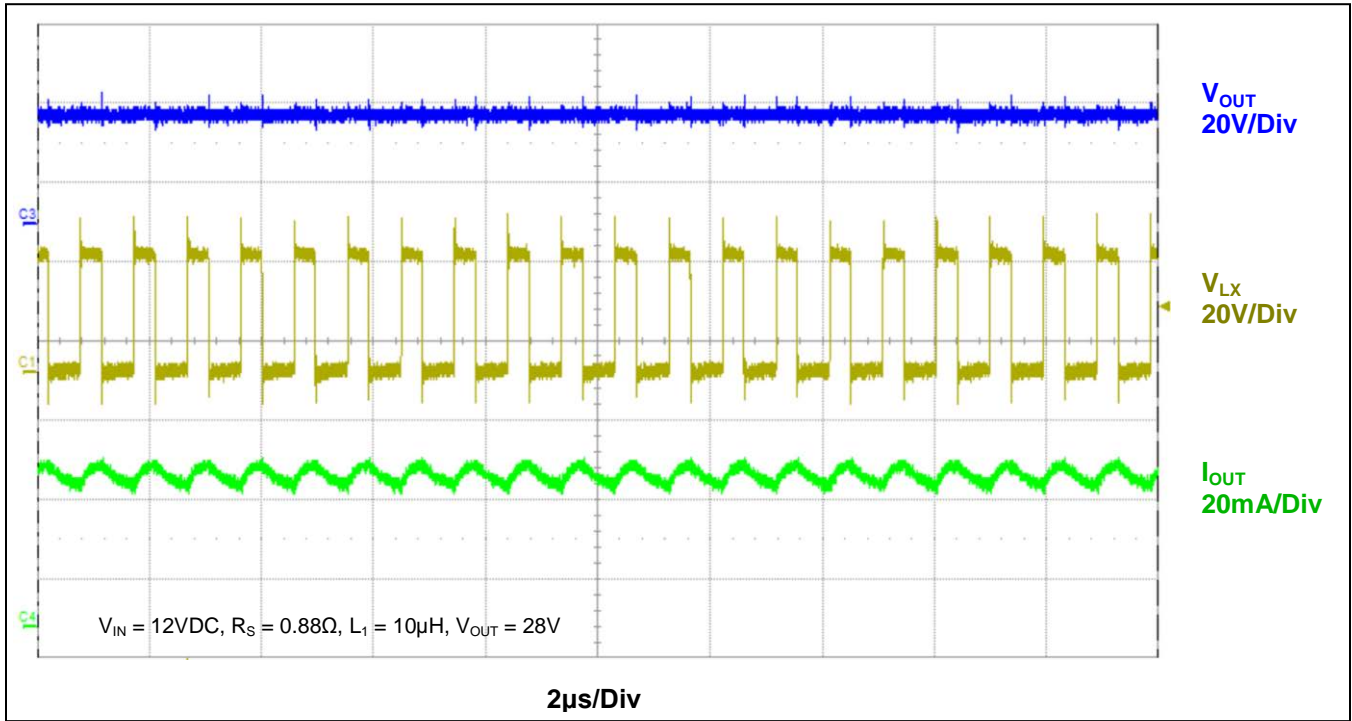
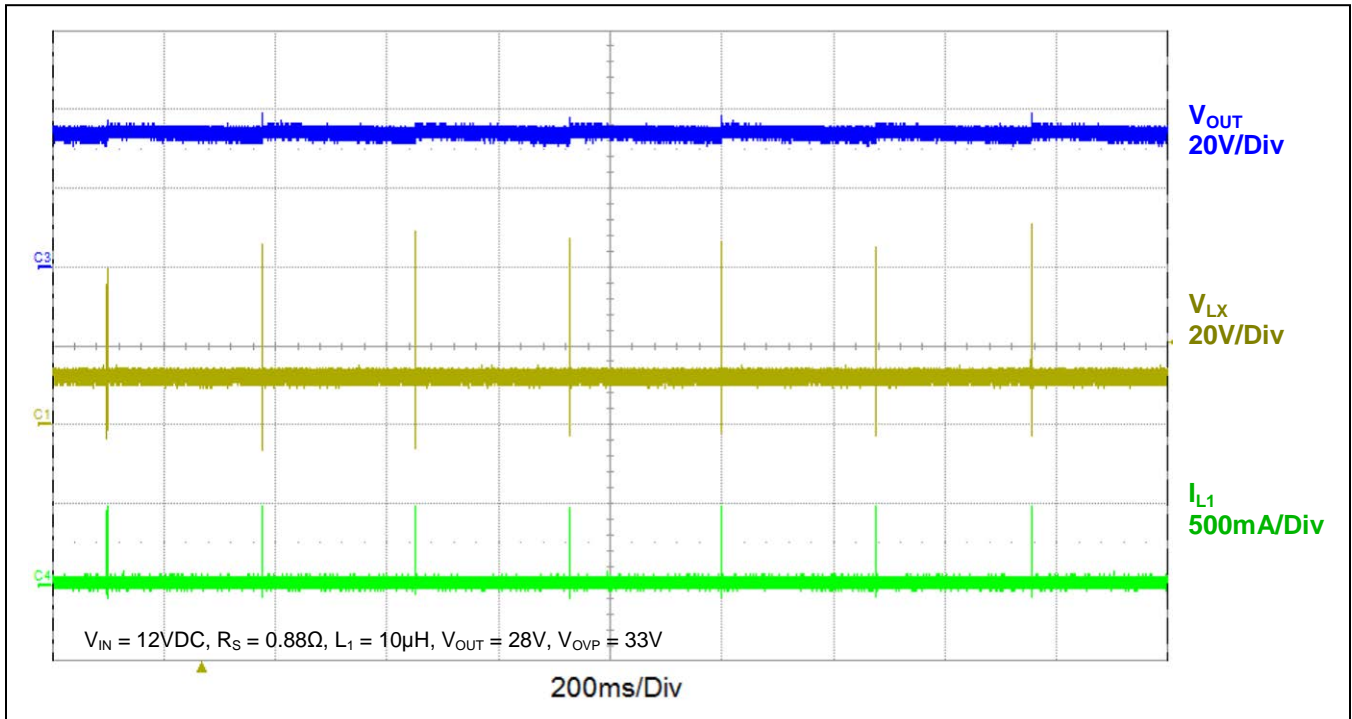

Figure 1.13 V_{OUT} , V_{LX} , and I_{L1} when Over-Voltage Protection (OVP) Threshold is Exceeded



2 Circuit Description

The ZLED7015 is a constant-current boost converter that can also function as a constant voltage driver for LED applications. The boost converter topology features an internal 35V power switch and feedback circuit to control the output to the LED string. Optimal performance is achieved by operating in continuous conduction mode within the application's load current range; i.e., the current through inductor L1 is always above 0A. The output current is set by an external resistor and the device supports DC linear or PWM dimming. Additional device features include selectable open-load/over-voltage protection, over-temperature protection, under-voltage lockout, and an automatic soft-start function to minimize the inrush current during startup.

2.1 EN Pin, VP Pin, and Soft-Start Function

The EN pin can be used to enable or disable the ZLED7015. When the voltage on the EN pin rises above the ON threshold voltage V_{ENon} specified in Table 1.3, the ZLED7015 begins its "soft-start." When the voltage at EN falls below the OFF threshold voltage V_{ENoff} , the ZLED7015 shuts down. There is a hysteresis between V_{ENon} and V_{ENoff} to prevent intermittent operation.

The ZLED7015's internal "soft-start" function ensures a smooth device start-up by preventing excessive in-rush current and providing a controlled rise in the output current. When the soft-start function is initiated, the internal circuitry clamps the internal switch current threshold to zero during a 1millisecond delay. The soft-start function then gradually increases the internal switch current threshold over a 4-5 msec period. See Figure 1.11 for an illustration of typical waveforms during start-up.

Important: The EN pin requires termination. If the EN pin is not used to control operation, connect it to the positive power supply through a 100kΩ resistor. Do not allow the EN pin to float.

The VP pin is connected to the ZLED7015's internal power regulator and requires an external bypass capacitor, C_{VP} , to ensure correct device operation.

2.2 Output Current Control

The LED current is determined by the voltage across the external sense resistor R_S , which is fed back to the input FB. Internally, this is compared with the internal feedback reference voltage, V_{FB} (see typical application shown on page 2), and the duty cycle of the internal power switch is adjusted to reduce or increase the output current I_{OUT} . Selection of R_S is discussed in section 2.2.1, and other external components are discussed in section 3. Dimming can be controlled by superimposing a DC or filtered pulse-width modulated (PWM) signal on the feedback voltage from R_S . Refer to sections 2.2.2 and 2.2.3, respectively, for more details.

2.2.1 Output Current and R_S

The ZLED7015 continually adjusts the output current, I_{OUT} , in order to maintain the voltage level at the FB pin equal to the internal feedback reference voltage, V_{FB} . Equation (1) shows the basic relationship between I_{OUT} , V_{FB} , and R_S for the basic application shown in Figure 2.1.

$$I_{OUT} = \frac{V_{FB}}{R_S} = \frac{0.3V}{R_S} \tag{1}$$

Where

I_{OUT} = Average output current through the LED(s) in amperes

V_{FB} = Internal feedback reference voltage (see Table 1.3, parameter 1.3.7)

Figure 2.1 Typical Application Circuit

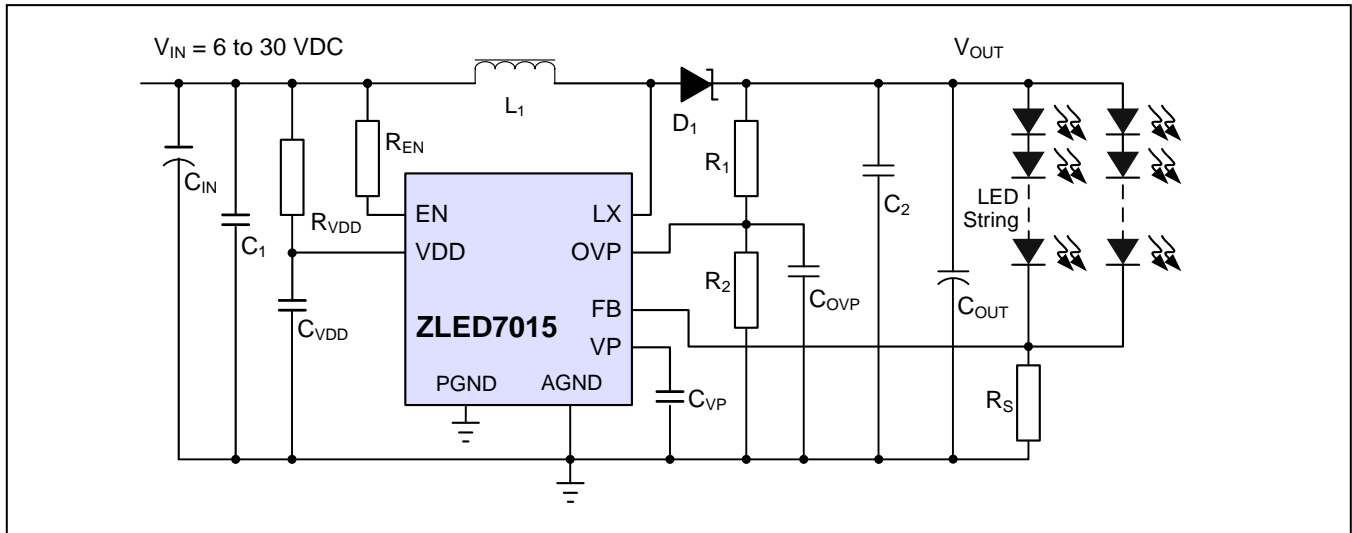

2.2.2 Dimming via External DC Voltage Control

The LED output current can be set below the nominal average value defined on section 2.2.1 by using an external DC voltage control signal superimposed on the FB pin as shown in the example circuit in Figure 2.2. As the DC control signal, V_{DC} , increases, the current through R_3 increases with a subsequent increase in the voltage at the FB pin. This causes the ZLED7015 to compensate by reducing the output current through the LED string. Consequently, the output current is inversely proportional to the DC control voltage.

Note: It is important to ensure that the LED output voltage V_{OUT} remains higher than the input voltage V_{IN} in dimming applications.

Figure 2.2 Example Circuit for Controlling Output Current via an External DC Control Voltage

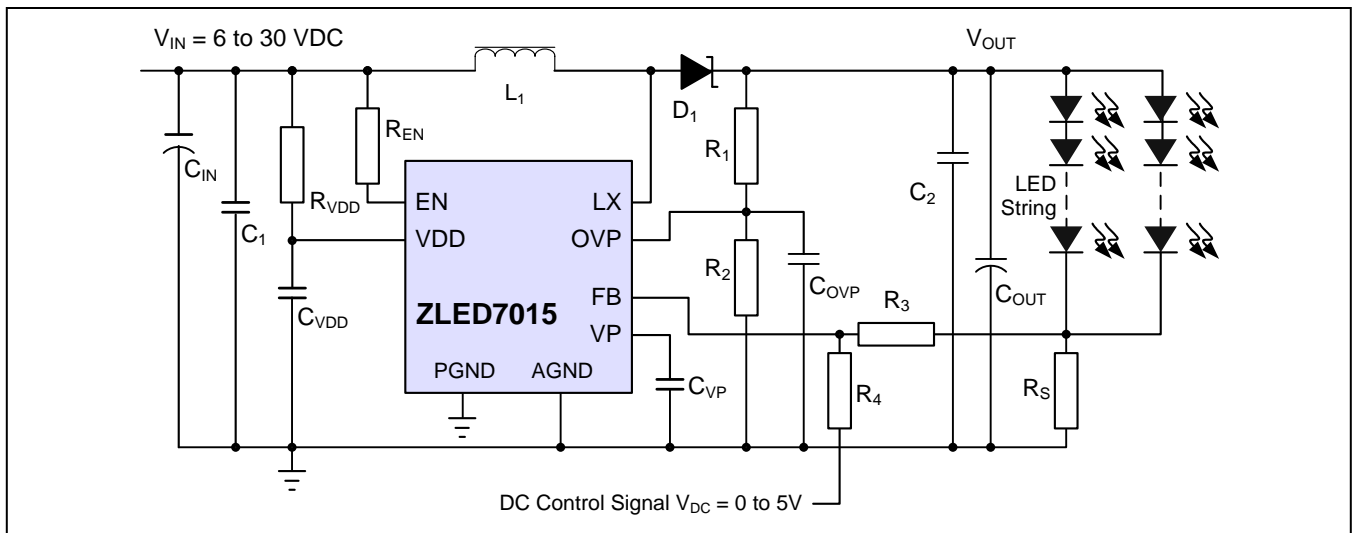

The output current controlled by the DC voltage on FB can be calculated using equation (2):

$$I_{OUT} = \frac{V_{FB} - \left(\frac{R_3 \times (V_{DC} - V_{FB})}{R_4} \right)}{R_S} \tag{2}$$

Where

- I_{OUT} = Output current through the LED(s) with a DC control voltage
- V_{FB} = Internal feedback reference voltage (Table 1.3, parameter 1.3.7)
- V_{DC} = External DC control voltage

2.2.3 Dimming via PWM Control

An external pulse-width modulated (PWM) signal input can be used to control the LED output current by driving the output current to a value below the nominal average value defined in section 2.2.1. A microcontroller can be used to generate the PWM signal. See Figure 2.3 for an example circuit. The PWM signal is superimposed on the feedback voltage from R_S at the FB pin via the input filter R_5/C_3 and R_4 , which produces a DC voltage with a ripple. This method of controlling dimming is similar to the external DC voltage control described in section 2.2.2. The duty cycle of the PWM signal regulates the filtered DC voltage level, which inversely controls the LED output current level. When the duty cycle is at 100%, the output current is at the minimum. With a 0% duty cycle, the output current is at the maximum.

Recommendation: With a PWM signal of 0 to 5V, use an R_3 value of 10k Ω and a PWM frequency of >2kHz to minimize the filtered PWM voltage ripple.

Note: It is important to ensure that the LED output voltage V_{OUT} remains higher than the input voltage V_{IN} in dimming applications.

Figure 2.3 Example Circuit for Controlling Output Current via a PWM Control Signal

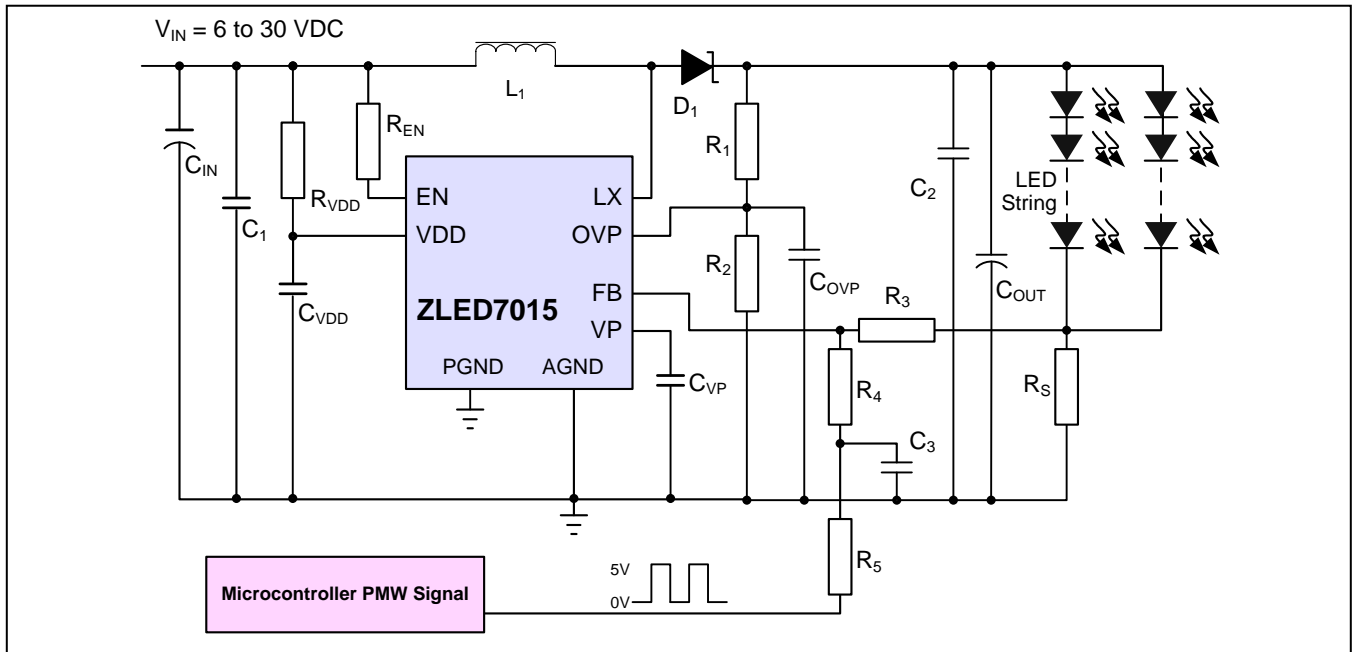

The output current controlled by the PWM voltage on FB can be calculated using equation (3):

$$I_{OUT} = \frac{V_{FB} - \left(\frac{R_3 \times (V_{PWM} \times D_{PWM} - V_{FB})}{R_4 + R_5} \right)}{R_s} \quad (3)$$

Where

I_{OUT} = Output current through the LED(s) with a PWM control voltage

V_{FB} = Internal feedback reference voltage (see Table 1.3, parameter 1.3.7)

V_{PWM} = External PWM control voltage

D_{PWM} = Duty cycle of the PWM control signal

2.2.4 Microcontroller LED Control

A microcontroller can control the LED output current by providing a PWM control signal to the FB pin as described in section 2.2.3.

Depending on the application, the microcontroller can also be used to control the shutdown circuitry via the EN pin (see section 2.1) providing a fast and smooth transition to shutdown.

2.2.5 Constant Voltage Application

In addition to functioning as a constant-current boost converter for driving an LED string, the ZLED7015 can be configured as a constant-voltage boost converter for other applications. Figure 2.4 demonstrates a typical circuit for this application.

The output voltage controlled by the values of R_3 and R_s can be calculated using equation (4):

$$V_{OUT} = V_{FB} \times \frac{(R_3 + R_s)}{R_s} \quad (4)$$

Where

V_{OUT} = Output voltage to the load

V_{FB} = Internal feedback reference voltage (Table 1.3, parameter 1.3.7)

Figure 2.4 Example Circuit for Constant Voltage Source Applications

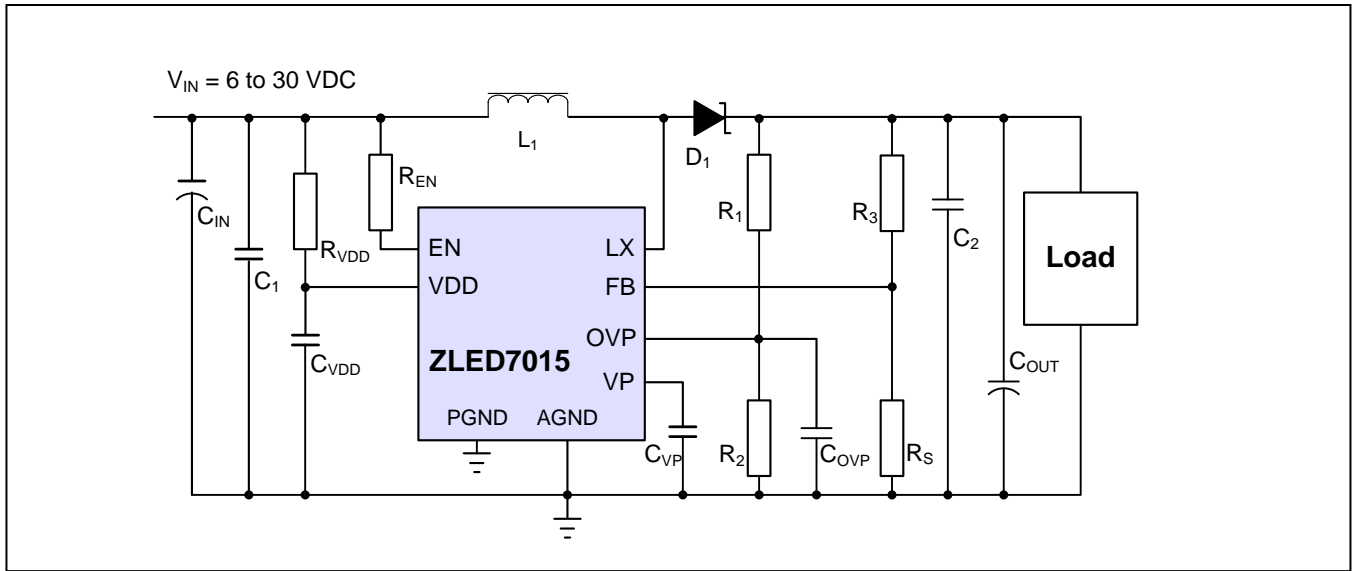

3 Application Circuit Design

The following sections cover selection of the external components shown in the typical application on page 1.

3.1 External Component – R_S

Recommendation: Use precision resistors ($\pm 1\%$ or better tolerance) for the R_S resistor to ensure accurate control of the LED current.

See section 2.2.1 for the equation for selecting the value of R_S , which sets the nominal current output.

3.2 External Component – Inductor L_1

Designing the circuit so that the current through inductor L_1 is always above 0V (i.e., continuous mode) typically gives the best performance due to improved load regulation and reduced output ripple. Select an inductor that has a saturation current and a current rating greater than the mean input current.

The inductor value selection requires trade-offs between unwanted ripple current and parasitic effects. A larger value inductor reduces inductor ripple current, resulting in less output ripple voltage; however, higher values also increase parasitic resistance, which can degrade performance. For most applications, a 10 μ H inductor with a saturation current >2.5 A is adequate. See section 7.4 for layout restrictions.

3.3 External Components – Input Decoupling Capacitors C_1 and C_{IN}

The input capacitors C_1 and C_{IN} minimize the input voltage noise and ripple. Recommendation: use a 22 μ F or larger low-ESR electrolytic capacitor for C_{IN} in parallel with a 1 μ F ceramic capacitor rated at greater than the input voltage plus a safety margin for C_1 .

3.4 External Component – Output Capacitors C_2 and C_{OUT}

The output capacitors C_2 and C_{OUT} minimize the output voltage ripple. Recommendation: use a 22 μ F or larger low-ESR electrolytic capacitor for C_{OUT} in parallel with a 1 μ F ceramic capacitor rated at greater than the output voltage plus a safety margin for C_2 .

3.5 External Component – Diode D_1

For the diode D_1 , select a high-speed, low-capacitance Schottky diode with low reverse leakage at the maximum operating voltage and temperature to ensure maximum efficiency and performance.

Important: Choose diodes with a continuous current rating higher than the maximum output load current and a peak current rating above the peak coil current. When operating above 85°C, the reverse leakage of the diode must be addressed because it can cause excessive power dissipation in the diode, especially when the output voltage is relatively high. Its reverse breakdown voltage must be greater than the over-voltage protection level V_{OVP} (see section 4.2).

Note: Silicon diodes have higher forward voltage and higher voltage overshoot before they start conducting, which can increase the peak voltage on the LX output. Ensure that the total voltage appearing on the LX pin, including supply ripple, is within the specified range (see Table 1.1).

3.6 Additional External Components

For the VDD input, connect resistor R_{VDD} to the positive power supply and connect ceramic capacitor C_{VDD} to ground. Recommendations: use 1 μ F for C_{VDD} ; use 300 Ω for R_{VDD} with input voltages ≥ 8 V, use 50 Ω for R_{VDD} with input voltages < 8 V.

For the VP pin, connect a 10 μ F ceramic bypass capacitor to ground (C_{VP}).

If the EN pin is not used, connect a 100k Ω resistor to the positive power supply (R_{EN}). Do not allow the EN pin to float.

4 Operating Conditions

4.1 Under-Voltage Lockout

The under-voltage lockout (UVLO) monitors the ZLED7015's internal regulator output voltage, VP, to ensure correct operation of the internal circuitry. When the VP voltage is lower than the UVLO threshold V_{UVLO} , the ZLED7015 disables the internal power switch. If the VP voltage reaches a level higher than the UVLO threshold plus UVLO hysteresis ($V_{UVLO}+V_{UVLO_HYS}$) the UVLO turns off and the internal power switch is re-enabled. See parameters 1.3.14 and 1.3.15 in section 1.3 for the UVLO threshold and hysteresis.

4.2 Over-Voltage Threshold and Open-Circuit Protection

If the LED string becomes open or the FB pin is shorted to ground, the ZLED7015 would normally continually boost the output voltage to potentially damaging levels. To prevent this, the ZLED7015 includes an integrated over-voltage protection (OVP) mechanism. If the output voltage reaches the ZLED7015's OVP threshold V_{OVP} , the protection circuitry is triggered and the device automatically turns off the internal switch, stopping the boost function and protecting the device. Once the output voltage falls below the OVP threshold minus OVP threshold hysteresis ($V_{OVP_TH}-V_{OVP_TH_HYS}$), the device will enter soft-start mode.

The OVP threshold V_{OVP} for the ZLED7015 is selectable via the R1 and R2 resistor values determined by equation (5):

$$V_{OVP} = V_{OVP_TH} \times \frac{(R_1 + R_2)}{R_2} \quad (5)$$

Where

V_{OVP} = Over-voltage protection threshold

V_{OVP_TH} = Internal over-voltage threshold reference voltage (see Table 1.3, parameter 1.3.16)

Important: Care must be taken to select proper R₁ and R₂ values to ensure proper functioning of the ZLED7015. See specification 1.3.16 in Table 1.3 for the over-voltage protection threshold voltage. Set V_{OVP} 3V higher than the normal operation output voltage.

Important: When setting V_{OVP} , care must be taken to ensure V_{OUT} cannot exceed 35V.

Minimize noise coupling on the OVP pin, which could interfere with proper protection, by connecting a 10nF ceramic capacitor to GND from OVP (C_{OVP}).

4.3 Over-Temperature Protection

The ZLED7015 features on-chip over-temperature protection. If its internal temperature exceeds the over-temperature protection (OTP) threshold, T_{OTP} , due to high power dissipation and improper heat sinking, the internal power switch is disabled. Once the internal temperature has fallen below the OTP threshold minus the OTP threshold hysteresis ($T_{OTP} - T_{OTP_HYS}$), the ZLED7015 enters the soft-start mode (see section 2.1).

Refer to Table 1.1 for the maximum package power dissipation specifications for the ZLED7015's MSOP-10 package.

5 ESD/Latch-Up-Protection

All high voltage pins (1, 4, 5, 9, and 10) have an ESD protection of $>\pm 2500V$ according to the Human Body Model (HBM). The ESD test follows the Human Body Model based on MIL 883-H, Method 3015.8

All low voltage pins (2, 3, 6, 7, and 8) have an ESD protection of $>\pm 4000V$ according to the Human Body Model (HBM). The ESD test follows the Human Body Model based on MIL 883-H, Method 3015.8

All pins pass the latch-up test based on the JEDEC Standard No. 78B, December 2008.

6 Pin Configuration and Package

The ZLED7015 package is an MSOP-10, which has a thermal resistance (junction to ambient) of $R_{\theta JA} = 60^{\circ}C/W$.

Figure 6.1 ZLED7015 Pin Configuration—MSOP-10 Package

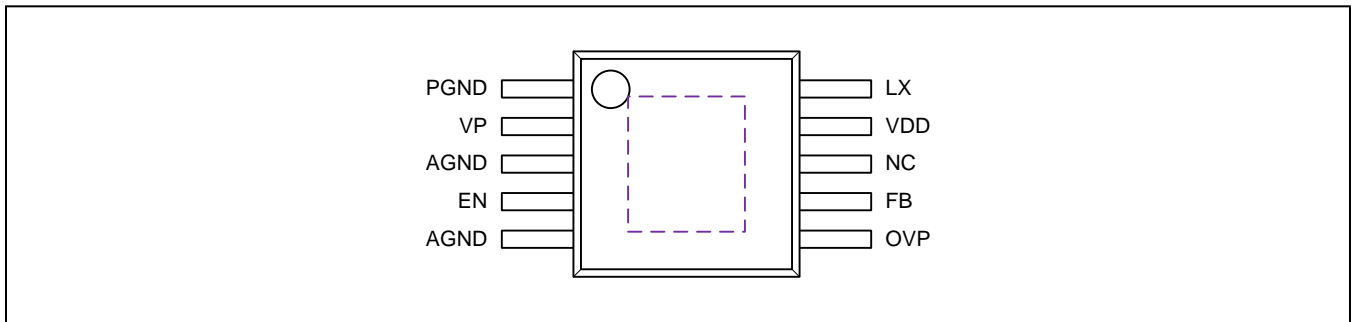
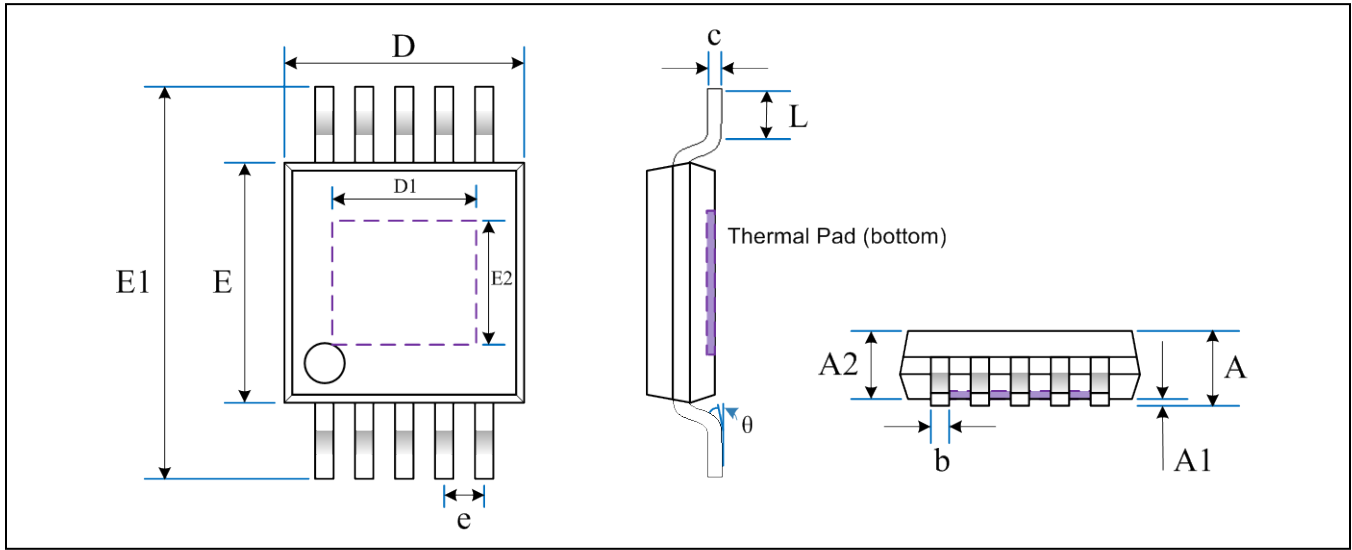

Table 6.1 Pin Description MSOP-10

Pin Name	No.	Description
PGND	1	Power ground
VP	2	Internal 5V linear regulator output. VP is the power supply for the internal switch gate driver and the internal control circuitry. Use a 10 μ F ceramic bypass capacitor between VP and ground.
AGND	3	Analog (signal) ground.
EN	4	Enable control input. Important: Do not allow this pin to float.
AGND	5	Analog (signal) ground.
OVP	6	Over-voltage protection control input.
FB	7	Feedback voltage input. The nominal average output current is set by the value of R_S connected from FB to GND – see section 2.2.1 for details. Important: Do not allow the FB pin to float.
n.c.	8	No connection
VDD	9	Supply voltage (6V to 30V)—see section 7 for layout considerations.
LX	10	Drain of the internal switch. Connect the power inductor between LX and the power supply. Connect the output rectifier D_1 between LX and the output circuit. See section 1.1 for output range specifications.
Thermal Pad		Connect to ground.

Figure 6.2 MSOP-10 Package Dimensions for the ZLED7015



Symbol	Dimension (mm, except θ)		Symbol	Dimension (mm)	
	Min	Max		Min	Max
A	0.82	1.10	D	2.90	3.10
A1	0.02	0.15	D1	1.70	1.90
A2	0.75	0.95	e	0.50 BSC	
b	0.18	0.28	E	2.90	3.10
c	0.09	0.23	E1	4.75	5.05
			E2	1.45	1.65
θ	0°	6°	L	0.40	0.80

7 Layout Requirements

Follow these layout guidelines to avoid circuit instability and EMI vulnerability, especially with high current or high switching frequency applications.

Important: Route traces connecting the feedback network to the FB and OVP pin away from the L_1 inductor, the D_1 Schottky diode, and the LX pin. These traces should be as short as possible. Shield the FB pin and feedback network with a ground plane or trace to prevent noise coupling.

7.1 General Considerations and Ground Traces

Make the ground traces as wide and short as possible. To prevent a signal ground shift, keep traces for the signal ground (pin 5) separate from traces for the power ground (pin 1). Connect the signal and power ground traces together at either the large ground plane or the negative terminal of C_{IN} .

Connect the grounds for other components to the signal ground.

Use wide traces for connection of the high current loop.

7.2 Layout Considerations for C_1 , C_{IN} , C_2 and C_{OUT}

Place C_1 , C_2 and C_{OUT} as close as possible to the ZLED7015 to minimize ripple. The C_{IN} input decoupling capacitor must be placed as close as possible to the VDD pin to minimize power supply noise, which can reduce efficiency.

7.3 Layout Considerations for the EN Pin

Important: Do not allow the EN pin to float. It must be terminated if it is not used.

7.4 Layout Considerations for the LX Pin, L_1 External Coil, and D_1 Diode

Minimize the length of circuit board traces connected to the LX pin because it is a fast switching output.

Place L_1 and D_1 as close as possible to the LX pin using traces that are as short and wide as possible. Avoid routing other traces crossing or in parallel with this node to minimize the noise coupling into this circuit.

7.5 Layout Considerations for the External Current Sense Resistor (R_S)

Any trace resistance in series with R_S must be taken into consideration when selecting its value. For the most accurate LED current control, use a trace that is as wide and short as possible for the R_S connection to ground. Connect it to the signal ground (pin 5), not the power ground (pin 1).

7.6 Layout Considerations for C_{VP} and C_{VDD}

For good filtering, connect C_{VP} as close as possible to the VP pin and place C_{VDD} as close as possible to the VDD pin.

7.7 Layout Considerations for the Thermal Pad

To optimize heat dissipation, solder the thermal pad on the back of the MSOP-10 package to the large ground plan.

8 Glossary of Terms

Term	Definition
LDO	Low Dropout Regulator
OTP	Over-Temperature Protection
OVP	Over-Voltage Protection
UVL	Under-Voltage Lockout

9 Ordering Information

Product Sales Code	Description	Package
ZLED7015ZI1R	ZLED7015 – 1MHz Boost Converter with Internal 35V Switch	MSOP-10 (Tape & Reel)
ZLED7015KIT-E1	ZLED7015-E1 Evaluation Board, 1 ZLED-PCB10, and 5 ZLED7015 ICs	Kit

10 Document Revision History

Revision	Date	Description
1.00	December 20, 2011	First Issue.
	April 20, 2016	Changed to IDT branding.

IMPORTANT NOTICE AND DISCLAIMER

RENESAS ELECTRONICS CORPORATION AND ITS SUBSIDIARIES (“RENESAS”) PROVIDES TECHNICAL SPECIFICATIONS AND RELIABILITY DATA (INCLUDING DATASHEETS), DESIGN RESOURCES (INCLUDING REFERENCE DESIGNS), APPLICATION OR OTHER DESIGN ADVICE, WEB TOOLS, SAFETY INFORMATION, AND OTHER RESOURCES “AS IS” AND WITH ALL FAULTS, AND DISCLAIMS ALL WARRANTIES, EXPRESS OR IMPLIED, INCLUDING, WITHOUT LIMITATION, ANY IMPLIED WARRANTIES OF MERCHANTABILITY, FITNESS FOR A PARTICULAR PURPOSE, OR NON-INFRINGEMENT OF THIRD-PARTY INTELLECTUAL PROPERTY RIGHTS.

These resources are intended for developers who are designing with Renesas products. You are solely responsible for (1) selecting the appropriate products for your application, (2) designing, validating, and testing your application, and (3) ensuring your application meets applicable standards, and any other safety, security, or other requirements. These resources are subject to change without notice. Renesas grants you permission to use these resources only to develop an application that uses Renesas products. Other reproduction or use of these resources is strictly prohibited. No license is granted to any other Renesas intellectual property or to any third-party intellectual property. Renesas disclaims responsibility for, and you will fully indemnify Renesas and its representatives against, any claims, damages, costs, losses, or liabilities arising from your use of these resources. Renesas' products are provided only subject to Renesas' Terms and Conditions of Sale or other applicable terms agreed to in writing. No use of any Renesas resources expands or otherwise alters any applicable warranties or warranty disclaimers for these products.

(Disclaimer Rev.1.01)

Corporate Headquarters

TOYOSU FORESIA, 3-2-24 Toyosu,
Koto-ku, Tokyo 135-0061, Japan
www.renesas.com

Trademarks

Renesas and the Renesas logo are trademarks of Renesas Electronics Corporation. All trademarks and registered trademarks are the property of their respective owners.

Contact Information

For further information on a product, technology, the most up-to-date version of a document, or your nearest sales office, please visit www.renesas.com/contact-us/.