

Optimal Power Management for Renesas SOC's

Power Management Solutions for Renesas R-Car

Simplify Development & Reduce Time-to-Market

- Power and safety capability tailored to support R-Car SOC's
- Scalable family supports easy migration from entry to high-end
- Integration of R-Car with the PMICs is verified by Renesas

Reduce ECU Bill-of-Materials Cost

- Integrated FuSa support eliminates safety overhead, i.e. MCU, ADC, etc.
- Fast transient capability requires lower output capacitance
- High level of integration eliminates the need for external MOSFETs, diodes, feedback resistors, and compensation components

Optimize Mounting Requirements

- Single-phase regulators reduce PCB area due to elimination of external components
- Best-in-class efficiency of high-current core regulator lowers heat generation, reducing cooling requirements on the PCB

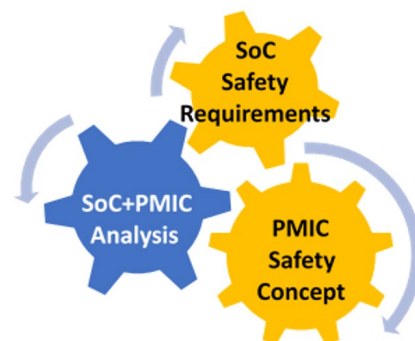
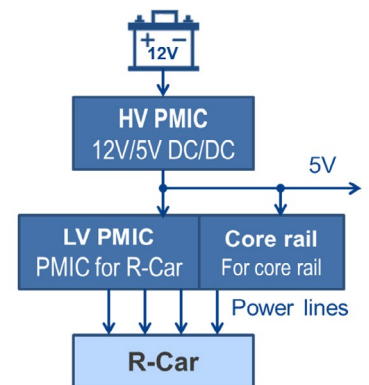

Solution Example

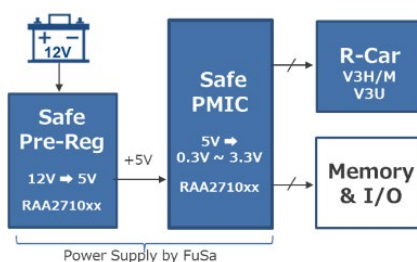

System-level Benefits

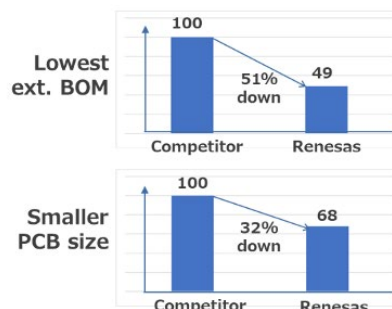

R-Car V3H reference design including Renesas PMICs and 5P35023 Timing IC

Complete Clock Solutions for Complex ADAS Systems from Renesas Electronics

VersaClock® Timing Generators

[Automotive Clocks & Timing | Renesas](#)

Reduce board space with increased flexibility and performance

- “Any frequency” clock generation thanks to Fractional Output Divider technology
- Replace multiple crystal oscillators at lower overall system cost
- PCIe® Gen 1 - Gen 4
- Lower power and PCB area
- EMI reduction features: Spread Spectrum, Slew Rate reduction, ...
- AEC-Q100 qualified, IATF 16949 manufacturing, PPAP support

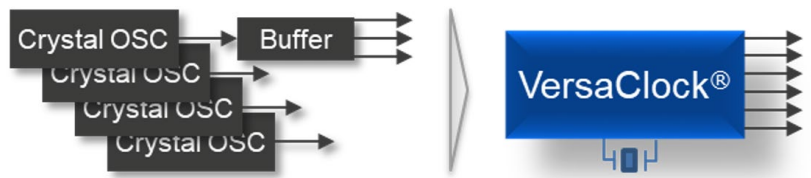

Qualify once, reuse everywhere!

- Factory programmed and tested One-Time-Programmable (OTP) ROM configurations
- New OTP-ROM configurations created in minutes with an easy-to-use webtool

VersaClock® 6E 5P49V60

- <500 fs rms Jitter (12 kHz - 20 MHz integration range)
- 4 fully configurable output pairs
- “Any Frequency” outputs, 1-350 MHz
- 4x4 QFN24 Wettable Flank
- Temperature Grade 2 (-40°C to +105°C)
- [5P49V60 VersaClock® 6E | Renesas](#)

VersaClock® 3S: 5P35021 – 5P35023

- 2 configurable output pairs + 1 or 3 single-ended
- <2 uA 32.768 kHz RTC clock
- DFC-Dynamic Frequency Control
- Configurable OE pin function
- 3x3 QFN20 / 4x4 QFN24 Wettable Flank
- Temperature Grade 2 (-40°C to +105°C)
- [5P35021 VersaClock® 3S | Renesas](#)
- [5P35023 VersaClock® 3S | Renesas](#)