

## 32-bit RISC CPU IP

# SH3-DSP CPU

### Overview

The SH3-DSP CPU interprets and executes the SH3-DSP instruction that extended the SH-3 instruction. For multiply instructions and DSP arithmetic instructions, calculations are performed with a digital signal processor (DSP) module.



### Key Features

- Compatible with object code level with SH-1, SH-2, and SH-3
- Built-in 32-bit internal data bus
- Supports abundant register groups
  - General-purpose register: Sixteen 32-bit registers (including eight 32-bit bank registers)
  - Control register: Eight 32-bit registers
  - System register: Four 32-bit registers
- The instruction execution time of the basic instruction corresponds to one instruction / cycle
- The logical address space corresponds to 4 GB
- Features of DSP
  - Mixing 16-bit instructions and 32-bit instructions
  - Supports multiplier, ALU, barrel shifter
  - Built-in 32-bit one-cycle multiplier corresponding to 16 bits x 16 bits
  - Supports large capacity DSP data register file
  - Supports extended Harvard architecture for DSP data bus
- Peripheral circuit
  - MMU, TLB, INTC, UBC, AUD, BSC, DMAC

### Block diagram

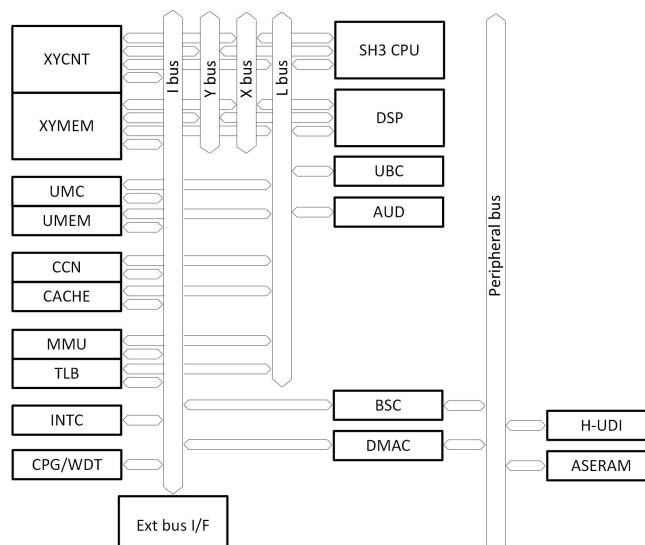

CTPD-24-093  
R06PF0077EJ0100