



IDT™ 89EBP0602Q SATA 6.25Gbps Evaluation Board Manual

(Evaluation Board: 18-702-000)

December 2010

6024 Silver Creek Valley Road, San Jose, California 95138
Telephone: (800) 345-7015 • (408) 284-8200 • FAX: (408) 284-2775
Printed in U.S.A.
©2010 Integrated Device Technology, Inc.

DISCLAIMER

Integrated Device Technology, Inc. reserves the right to make changes to its products or specifications at any time, without notice, in order to improve design or performance and to supply the best possible product. IDT does not assume any responsibility for use of any circuitry described other than the circuitry embodied in an IDT product. The Company makes no representations that circuitry described herein is free from patent infringement or other rights of third parties which may result from its use. No license is granted by implication or otherwise under any patent, patent rights or other rights, of Integrated Device Technology, Inc.

Boards that fail to function should be returned to IDT for replacement. Credit will not be given for the failed boards nor will a Failure Analysis be performed.

LIFE SUPPORT POLICY

Integrated Device Technology's products are not authorized for use as critical components in life support devices or systems unless a specific written agreement pertaining to such intended use is executed between the manufacturer and an officer of IDT.

1. Life support devices or systems are devices or systems which (a) are intended for surgical implant into the body or (b) support or sustain life and whose failure to perform, when properly used in accordance with instructions for use provided in the labeling, can be reasonably expected to result in a significant injury to the user.
2. A critical component is any components of a life support device or system whose failure to perform can be reasonably expected to cause the failure of the life support device or system, or to affect its safety or effectiveness.

IDT, the IDT logo, and Integrated Device Technology are trademarks or registered trademarks of Integrated Device Technology, Inc.



Notes

Description of the EBP0602Q SATA 6G Evaluation Board

Introduction 1-1
 Board Features 1-1
 Hardware 1-1
 Revision History 1-1

Installation of the EBP0602Q (SATA 6G) Evaluation Board

EBP0602Q Installation 2-1
 Hardware Description 2-1
 Power Sources 2-1
 External Power Source 2-2
 1.2V Voltage Regulator 2-2
 Boot Configuration Vector 2-2
 LEDs 2-3
 SATA Connectors 2-3
 EBP0602Q Board Figures 2-3

Schematics

Schematics 3-1

Notes



List of Tables

Notes

Table 2.1	Power Source Headers	2-1
Table 2.2	External Power Connector — J8	2-2
Table 2.3	Boot Configuration Vector Signals	2-2
Table 2.4	LED Indicators	2-3

Notes



List of Figures

Notes

Figure 2.1	EBP0602Q Board Topside Figure	2-3
Figure 2.2	EBP0602Q Board Bottom Figure	2-4

Notes



Description of the EBP0602Q SATA 6G Evaluation Board

Notes

Introduction

The 89HP0602Q 6.25Gbps Signal Repeater (also referred to as P0602Q in this manual) is a member of the IDT Signal Integrity Products family. It is a 2-channel repeater that supports 1 bidirectional SATA 6G lane. The main function of a signal repeater is to extend the reach of signals over a board trace or a cable beyond that which can be achieved natively by a SATA host controller or hard disk.

The 89EBP0602Q (EBP0602Q) evaluation board provides an evaluation platform for the P0602Q signal repeater. The evaluation board provided by IDT can be configured to test the functionality of the P0602Q device in a wide variety of system topologies.

Board Features

Hardware

- ◆ **P0602Q Signal Repeater for extending SATA 6G reach**
 - Single P0602Q device enabling 1 bidirectional SATA 6G lane on a single board
 - SATA connectors on each side of the board allow cables connecting to Host and Target devices.
- ◆ **Numerous user-selectable configurations set using onboard jumpers and DIP-switches**
 - Transmitter swing on the P0602Q Transmitter pins.
 - Receiver Equalization on the P0602Q Receiver pins.

Revision History

December 8, 2010: Initial publication of evaluation board manual.

Notes



Installation of the EBP0602Q (SATA 6G) Evaluation Board

Notes

EBP0602Q Installation

This chapter discusses the steps required to configure and install the EBP0602Q evaluation board. All available DIP switches and jumper configurations are explained in detail.

The primary installation steps are:

1. Configure jumper/switch options suitable for the evaluation or application requirements.
2. Connect the SATA 6G cable between the Host and EBP0602Q. Connect the SATA 6G cable between the EBP0602Q and the SATA device, such as an external SATA storage drive.
3. Apply power via USB or SATA power connectors.

The EBP0602Q board is typically shipped with all jumpers and switches configured to their default settings. In most cases, the board does not require further modification or setup.

For technical support, please visit the IDT website and fill out the Technical Support Request form at <http://www.idt.com/?app=TechSupport&prodFamily=signal%20integrity%20products>.

Hardware Description

The IDT 89HP0602Q is a 6.25Gbps Repeater IC that reconditions high-speed serial data streams. The 89HP0602Q contains two half-duplex data lanes, where each half-duplex lane consists of a differential equalizer, as well as a transmit driver that includes de-emphasis.

The EBP0602Q consists of single P0602Q device.

Basic requirements for the board to run are:

- SATA Host Controller.
- SATA Target Device (HDD).

Power Sources

The EBP0602Q can be powered via a 15-pin SATA or USB connector. Header W3 (see Table 2.1) is used to select the proper power source for the EBP0602Q from SATA 15-pin or USB connectors.

Power Source Headers		
Ref. Designator	Type	Description
W3	Header	1-2: 5V source from USB Connectors (J27) 2-3: 5V source from SATA 15-pin Power Connector (J8)

Table 2.1 Power Source Headers

Notes

External Power Source

External power is supplied to the EBP0602Q board through a 15-pin SATA power connector (J8) or USB connector (J27) via Header W3. The external power supply provides +5V to the EBP0602Q as described in Table 2.2. The +12V and +3.3V are unused.

Pin	Signal
1	3.3V
2	3.3V
3	3.3V
4	GND
5	GND
6	GND
7	5V
8	5V
9	5V
10	GND
11	SPIN-UP
12	GND
13	12V
14	12V
15	12V

Table 2.2 External Power Connector — J8

1.2V Voltage Regulator

A 5V to 1.2V voltage regulator (VR2) provides the 1.2V supply voltage (VDD) to the P0602Q.

Boot Configuration Vector

A boot configuration vector consisting of the signals listed in Table 2.3 is sampled by the P0602Q during power-on. The boot configuration vector defines the essential parameters for repeater operation and is set using DIP switches S2 as defined in Table 2.3.

Signal	Description
S1[1]: ARXEQ S1[2]: BRXEQ	Channel A & B Receiver Equalization. VSS: 2dB (Default) OPEN: 6dB VDD: 14dB
S1[3]: ATXSW S1[4]: BTXSW	Channel A & B Transmit Swing. VSS: 0.5Vdiff-pkpk OPEN: 0.8Vdiff-pkpk VDD: 0.95Vdiff-pkpk (Default)

Table 2.3 Boot Configuration Vector Signals

Notes

LEDs

There are LED indicators on the EBP0602Q which convey status feedback. A description of each is provided in Table 2.4.

Location	Color	Definition
DS4	Green	5V Power Indicator
DS3	Green	1.2V Power Indicator

Table 2.4 LED Indicators

SATA Connectors

The P0602Q repeater has no special orientation requirements with respect to the host controller or disk drive. SATA connectors J1 and J2 can be attached via cable to either the host or hard disk drive. It is important, however, to properly set the receiver equalization and transmitter line correctly based on the cable length being used.

EBP0602Q Board Figures

The top and bottom views of the board are shown in Figures 2.1 and 2.2 respectively.

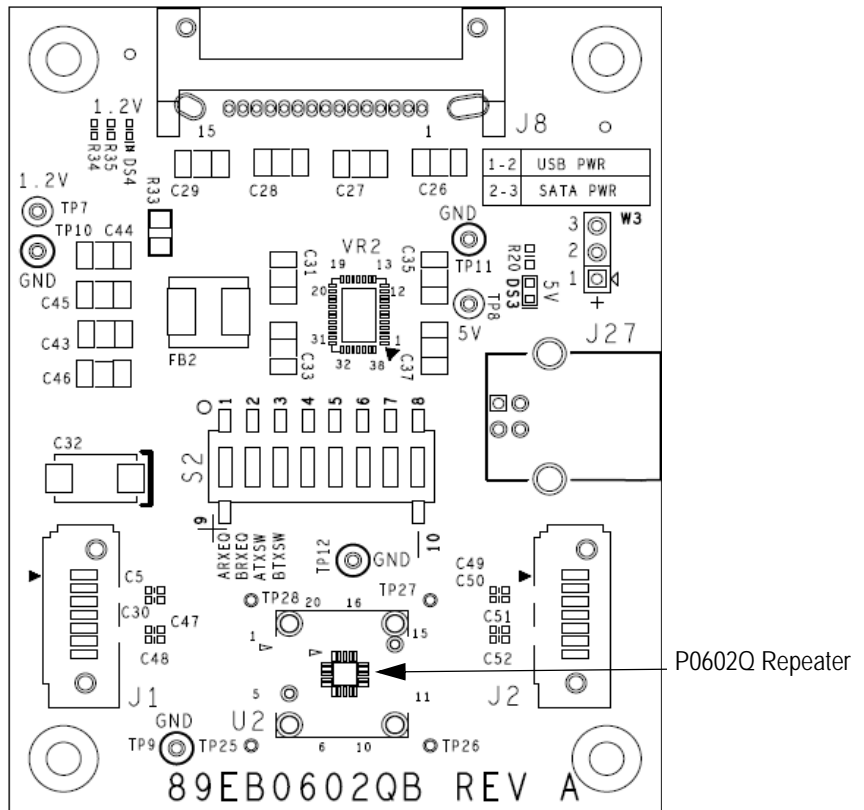

Figure 2.1 EBP0602Q Board Topside Figure

Notes

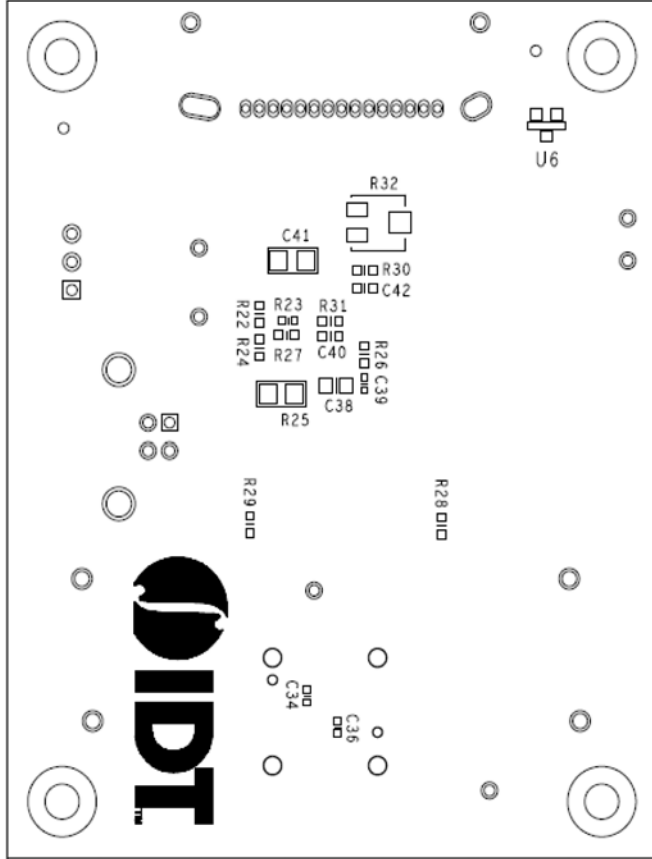

Figure 2.2 EBP0602Q Board Bottom Figure



Schematics

Notes

Schematics

REVISIONS				
DCN	REV	DESCRIPTION	DATE	CHANGE BY
	A	INITIAL RELEASE	2010-07-18	K. LEUNG

IDT 89HP0602Q SATA EVALUATION BOARDS

TABLE OF CONTENTS

89HP0602Q, POWER.....2

89HP0602Q, SATA CONNECTORS...3



CONFIDENTIAL PROPERTY OF INTEGRATED DEVICE TECHNOLOGY, INC.
 6024 SILVER CREEK VALLEY ROAD, SAN JOSE, CA 95138
 COPYRIGHT (C) 2010 IDT

TITLE			
89HP0602Q Evaluation Boards			
SIZE	DRAWING NO.	FAB P/N	REV.
B	P0602Q-U/S-EB-001	18-702-000	A
AUTHOR		CHECKED BY	
K. Leung		D. Huang	
Tue Nov 30 16:00:14 2010			SHEET 1 OF 3

D

C

B

A

D

C

B

A

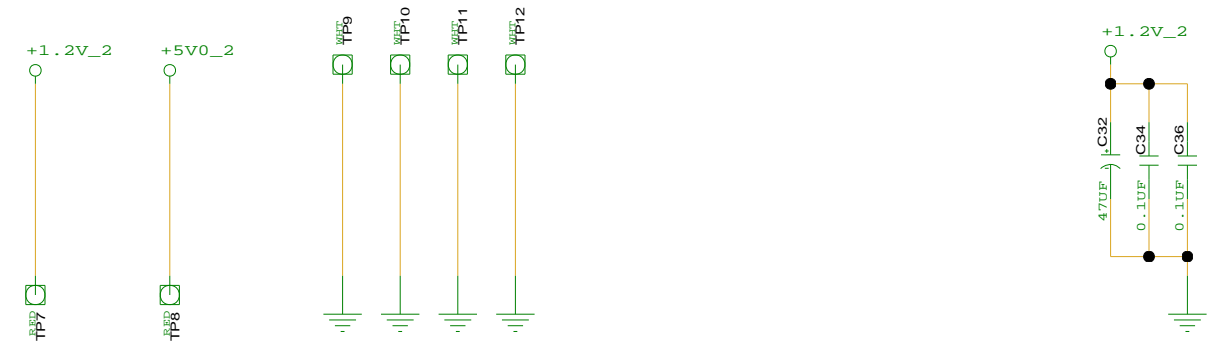
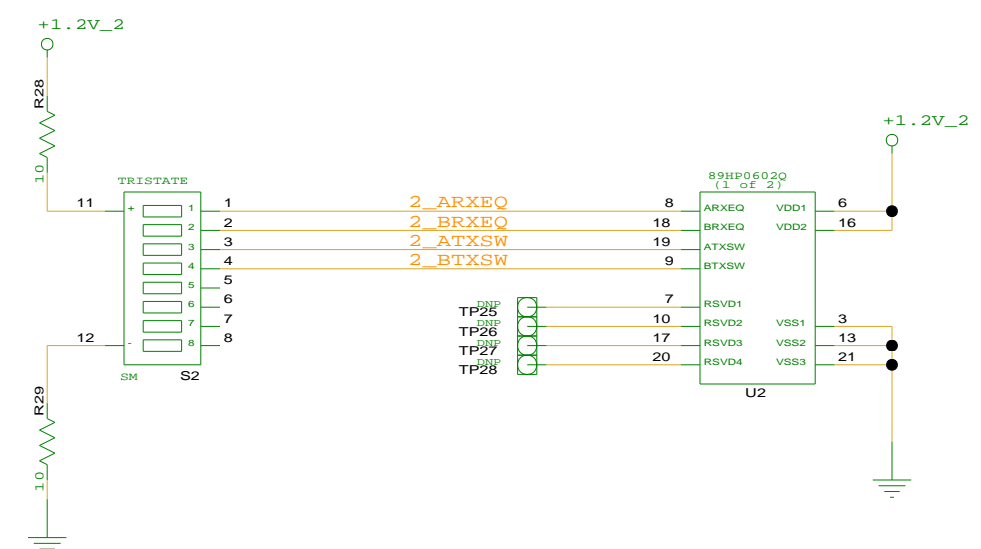
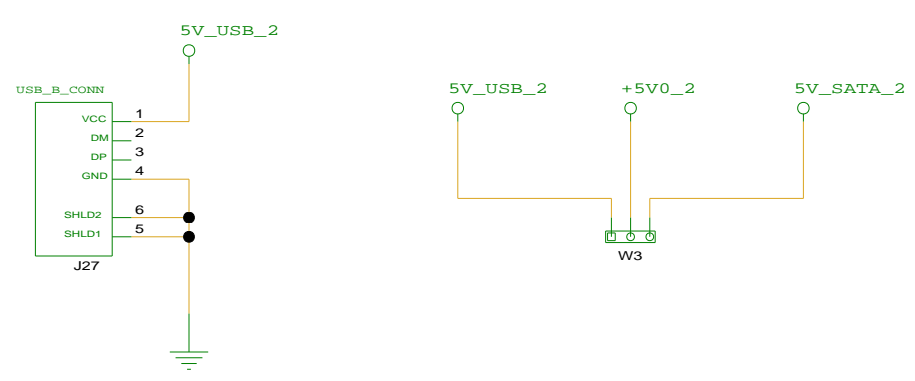
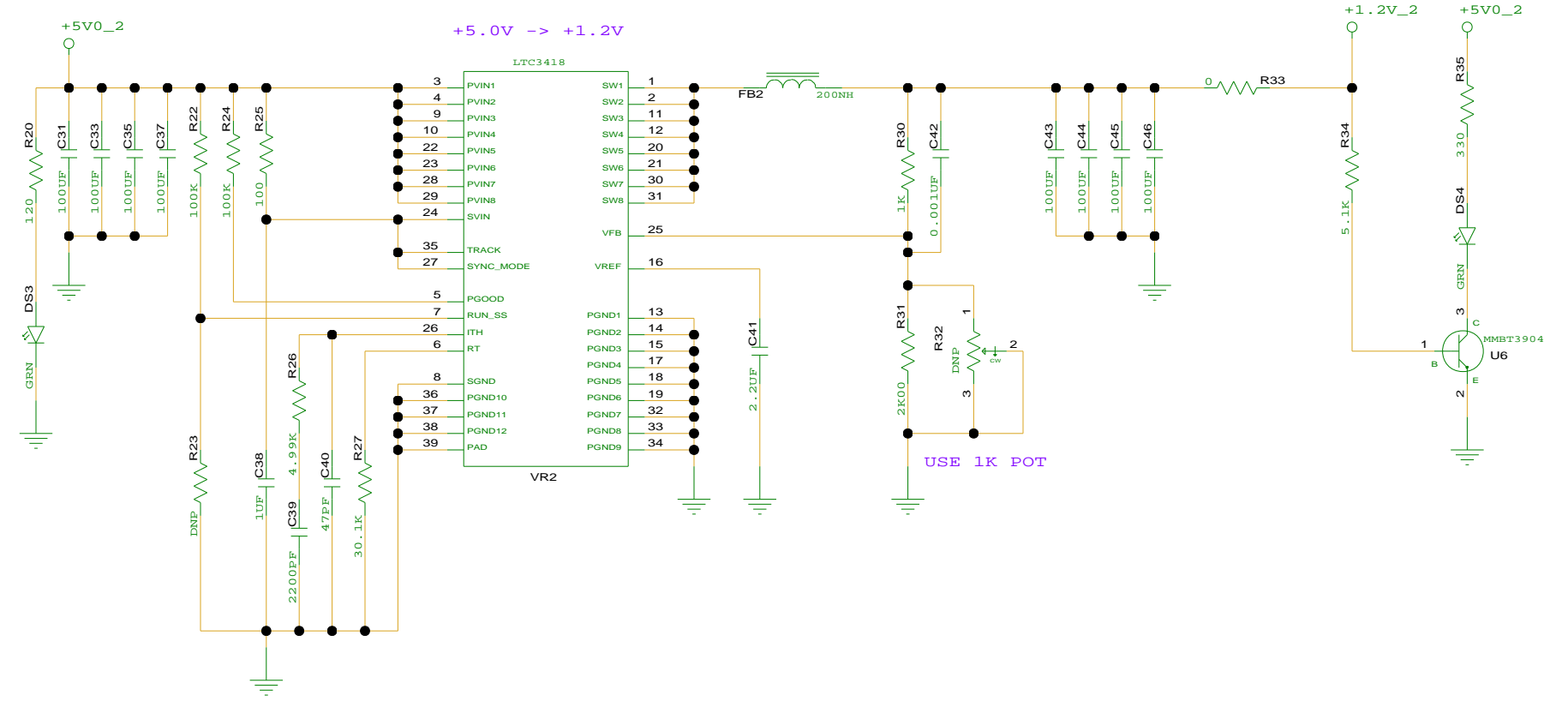
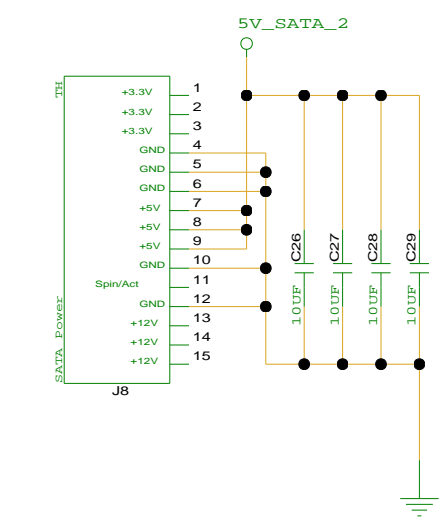

TITLE 89HP0602Q Evaluation Boards

89HP0602Q, POWER

SIZE	DRAWING NO.	FAB P/N	REV.
B	P0602Q-U/S-EB-001	18-702-000	A
AUTHOR		CHECKED BY	
K. Leung		D. Huang	
Tue Nov 30 16:00:14 2010			SHEET 2 OF 3

CONFIDENTIAL PROPERTY OF INTEGRATED DEVICE TECHNOLOGY, INC.
6024 SILVER CREEK VALLEY ROAD, SAN JOSE, CA 95138
COPYRIGHT (C) 2010 IDT

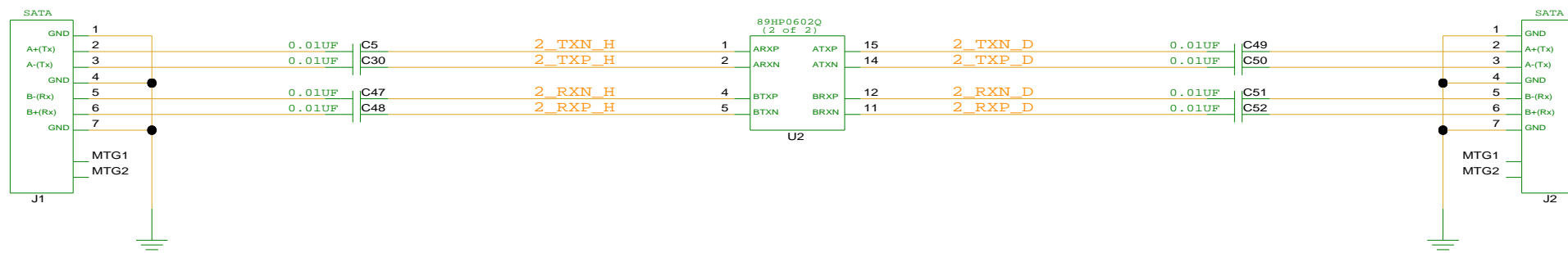

CONFIDENTIAL PROPERTY OF INTEGRATED DEVICE TECHNOLOGY, INC.
6024 SILVER CREEK VALLEY ROAD, SAN JOSE, CA 95138
COPYRIGHT (C) 2010 IDT

TITLE 89HP0602Q Evaluation Boards

89HP0602Q, SATA CONNECTORS

SIZE	DRAWING NO.	FAB P/N	REV.
B	P0602Q-U/S-EB-001	18-702-000	A

AUTHOR	CHECKED BY
K. Leung	D. Huang

Tue Nov 30 16:00:27 2010

SHEET 3 OF 3

IMPORTANT NOTICE AND DISCLAIMER

RENESAS ELECTRONICS CORPORATION AND ITS SUBSIDIARIES (“RENESAS”) PROVIDES TECHNICAL SPECIFICATIONS AND RELIABILITY DATA (INCLUDING DATASHEETS), DESIGN RESOURCES (INCLUDING REFERENCE DESIGNS), APPLICATION OR OTHER DESIGN ADVICE, WEB TOOLS, SAFETY INFORMATION, AND OTHER RESOURCES “AS IS” AND WITH ALL FAULTS, AND DISCLAIMS ALL WARRANTIES, EXPRESS OR IMPLIED, INCLUDING, WITHOUT LIMITATION, ANY IMPLIED WARRANTIES OF MERCHANTABILITY, FITNESS FOR A PARTICULAR PURPOSE, OR NON-INFRINGEMENT OF THIRD-PARTY INTELLECTUAL PROPERTY RIGHTS.

These resources are intended for developers who are designing with Renesas products. You are solely responsible for (1) selecting the appropriate products for your application, (2) designing, validating, and testing your application, and (3) ensuring your application meets applicable standards, and any other safety, security, or other requirements. These resources are subject to change without notice. Renesas grants you permission to use these resources only to develop an application that uses Renesas products. Other reproduction or use of these resources is strictly prohibited. No license is granted to any other Renesas intellectual property or to any third-party intellectual property. Renesas disclaims responsibility for, and you will fully indemnify Renesas and its representatives against, any claims, damages, costs, losses, or liabilities arising from your use of these resources. Renesas' products are provided only subject to Renesas' Terms and Conditions of Sale or other applicable terms agreed to in writing. No use of any Renesas resources expands or otherwise alters any applicable warranties or warranty disclaimers for these products.

(Disclaimer Rev.1.01 Jan 2024)

Corporate Headquarters

TOYOSU FORESIA, 3-2-24 Toyosu,
Koto-ku, Tokyo 135-0061, Japan
www.renesas.com

Trademarks

Renesas and the Renesas logo are trademarks of Renesas Electronics Corporation. All trademarks and registered trademarks are the property of their respective owners.

Contact Information

For further information on a product, technology, the most up-to-date version of a document, or your nearest sales office, please visit www.renesas.com/contact-us/.