

EU036 Multisensorboard

Hardware User's Guide

Contents

1. Overview.....	2
1.1 Components layout	3
1.2 Default Jumper Settings	4
2. Power Supply	6
3. Board Components.....	7
3.1 J-Link On-board Debugger	7
3.2 USB Device Port	8
3.3 ASi5 Connector	8
3.4 LEDs, Buttons and Dip-switches	10
3.5 PMODs	11
3.5.1 Host	11
3.5.2 Peripheral	11
3.6 Analog connectors.....	12
3.7 Arduino connectors	13
3.8 Sensors	14
3.8.1 FS2012 - Flow Sensor (not included).....	14
3.8.2 HS3001 - Temperature and Humidity Sensor	14
3.8.3 ISL29033 - Ambient Light Sensor	14
3.8.4 ISL29501 - Time of Flight Sensor	15
3.8.5 OB1203 - Digital RGB / Ambient Light, Proximity and Photoplethysmography Sensor.....	16
3.8.6 ZMOD4410 - Gas Sensor Module for TVOC and Indoor Air Quality Sensor	16
3.8.7 ZMOD4510 - Gas Sensor Module for Outdoor Air Quality sensor.....	17
4. Board Layout	18
References.....	20
Revision History	21

1. Overview

The Y-Multisensorboard_1 is a kit for the Renesas RA2A1 Microcontroller that also enables a quick evaluation of several Renesas sensors.

- Renesas RA2A1 Microcontroller
 - R7FA2A1AB3CFM
 - 64-pin LQFP package
 - 48 MHz Arm® Cortex-M23 core
 - 32 KB SRAM
 - 256 KB code flash memory
 - 8 KB data flash memory
- Sensors
 - **FS2012** - Flow Sensor (not included in the kit)
 - **HS3001** - Temperature and Humidity Sensor
 - **ISL29033** - Ambient Light Sensor
 - **ISL29501** - Time of Flight Sensor
 - **OB1203** - Digital RGB / Ambient Light, Proximity and Photoplethysmography Sensor
 - **ZMOD4410** - Gas Sensor Module for TVOC and Indoor Air Quality Sensor
 - **ZMOD4510** - Gas Sensor Module for Outdoor Air Quality sensor
- Connectivity
 - A Device USB port for the Main MCU
 - A Debug USB port connected to a SEGGER J-Link® On-Board interface, loaded on a Renesas S124 MCU, for debugging and programming of the RA2A1 MCU. A 10-pin JTAG/SWD interface is also provided for connecting optional external debuggers and programmers, disconnecting the On-Board J-Link.
 - Two PMOD connectors: host and peripheral
 - Arduino connectors for access to power and signals of the Main MCU
 - ASi5 interface
 - 2x Analog connectors
- Push buttons
 - General-purpose button
 - RA2A1 MCU reset
- 8x General-purpose LEDs
- 8x General-purpose dip-switches
- Different selectable power supply sources:
 - USB Device
 - USB J-Link
 - PMOD Peripheral connector
 - Arduino connector (VIN or 5V or 3.3V)
 - ASi5 connector

1.1 Components layout

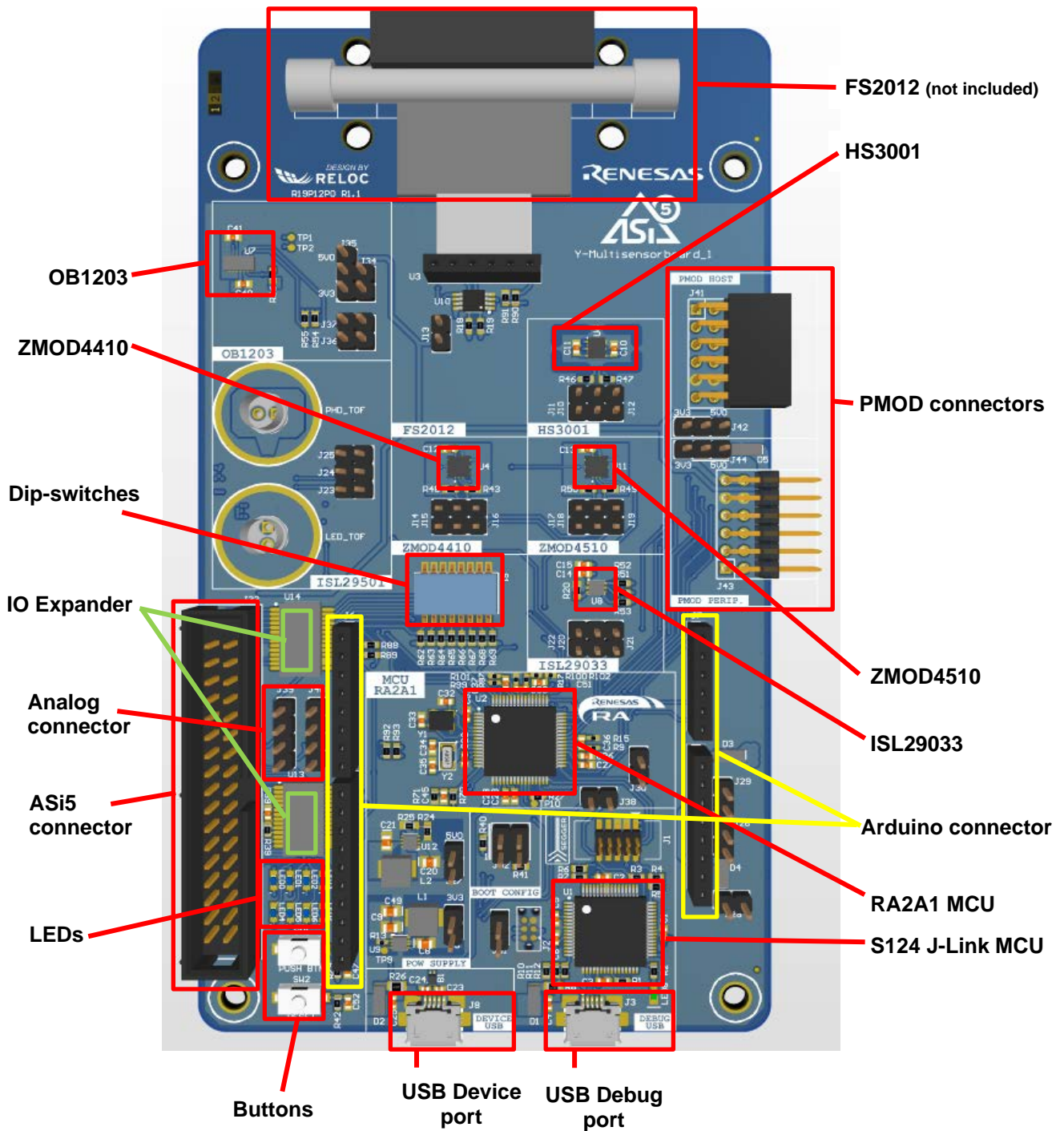

Figure 1: Top side

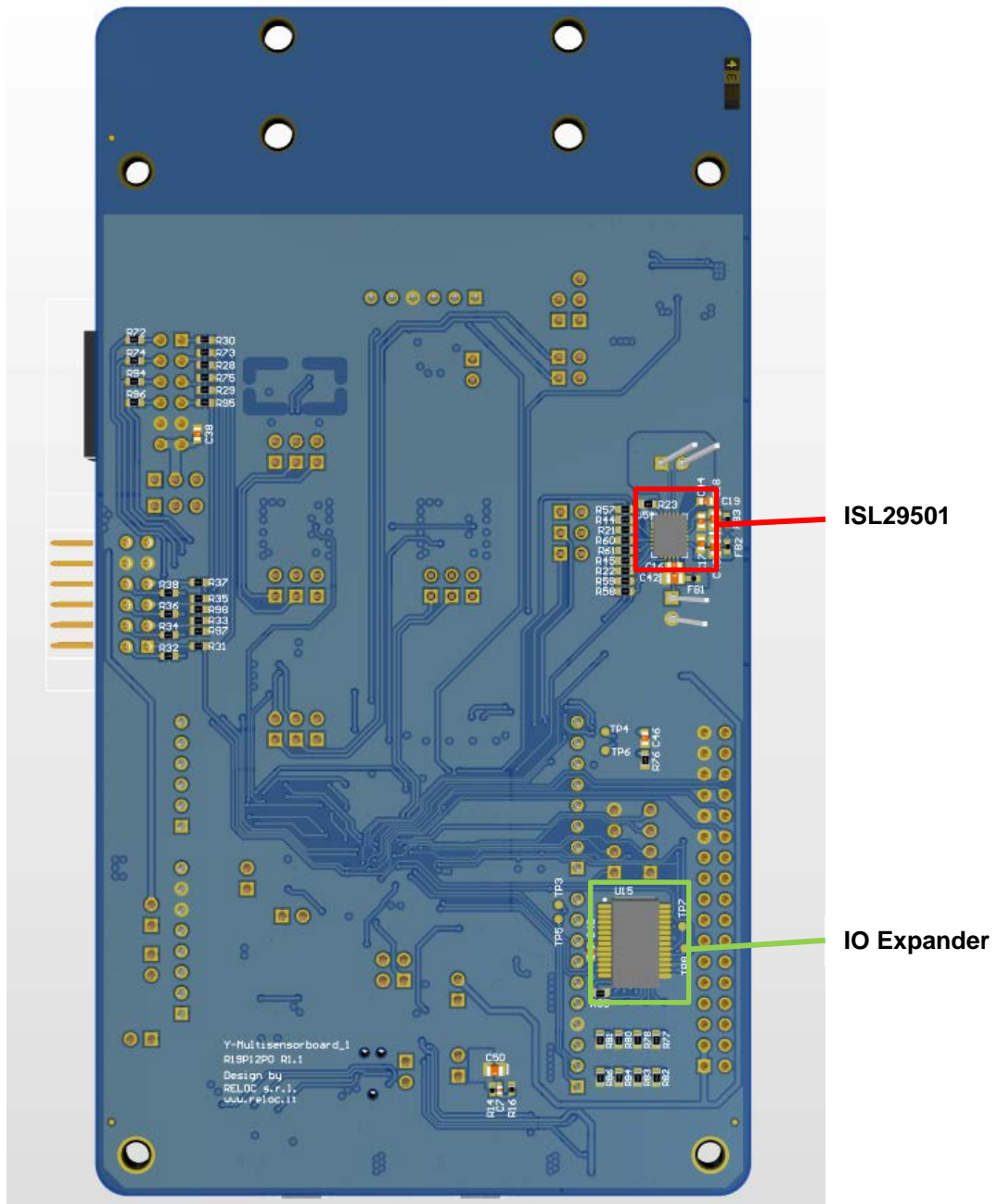

Figure 2: Bottom side

1.2 Default Jumper Settings

Jumper	Board section	Default state	Function
J9	Power supply	CLOSED	Use the internal DC/DC buck as +3.3 V main power supply source.
J10	HS3001	CLOSED	Connect the I2C SCL bus.
J11	HS3001	CLOSED	Connect the I2C SDA bus.
J12	HS3001	CLOSED	Provides power supply to the HS3001.

J13	FS2010	CLOSED	Provides power supply to the FS2012 connector.
J14	ZMOD4410	CLOSED	Provides power supply to the ZMOD4410.
J15	ZMOD4410	CLOSED	Connect the I2C SCL bus.
J16	ZMOD4410	CLOSED	Connect the I2C SDA bus.
J17	ZMOD4510	CLOSED	Provides power supply to the ZMOD4510.
J18	ZMOD4510	CLOSED	Connect the I2C SCL bus.
J19	ZMOD4510	CLOSED	Connect the I2C SDA bus.
J20	ISL29033	CLOSED	Connect the I2C SDA bus.
J21	ISL29033	CLOSED	Connect the I2C SCL bus.
J22	ISL29033	CLOSED	Provides power supply to the ISL29033.
J23	ISL29501	CLOSED	Connect the I2C SCL bus.
J24	ISL29501	CLOSED	Connect the I2C SDA bus.
J25	ISL29501	CLOSED	Provides power supply to the ISL29501.
J26	Power supply	OPEN	Use the +3.3 V of the Arduino connector as +3.3 V main power supply source.
J27	Power supply	CLOSED	Use the internal DC/DC boost as +5 V main power supply source.
J28	Power supply	OPEN	Use the +5 V of the Arduino connector as DC/DC buck power supply source.
J29	Power supply	OPEN	Use the +5 V of the Arduino connector as +5 V main power supply source.
J30	RA2A1 MCU	CLOSED	Provides power supply to the RA2A1 MCU.
J31	J-Link OnBoard	CLOSED	Provides power supply to the S124 MCU.
J32	RA2A1 MCU	CLOSED 1-2	Select the Boot mode of the RA2A1 (default Single-chip)
J34	OB1203	CLOSED	Provides power supply to logic part of the OB1203.
J35	OB1203	CLOSED 1-2	Provides power supply to internal LEDs of the OB1203.
J36	OB1203	CLOSED	Connect the I2C SCL bus.
J37	OB1203	CLOSED	Connect the I2C SDA bus.
J38	RA2A1 MCU	CLOSED	Connect J-Link programmer to the RA2A1 reset pin.
J42	PMOD host	CLOSED 2-3	Select the PMOD host power supply output (default +3.3 V).
J44	PMOD perip.	CLOSED 1-2	Select the PMOD peripheral power supply input (default +5 V).

2. Power Supply

The Multisensorboard has been designed in order to support different power sources. It can be powered from:

- the USB Device port
- the USB J-Link port
- the PMOD Peripheral connector (+3.3 V or +5 V)
- the Arduino connector (VIN or 5V or 3.3V)
- the ASi5 connector

Moreover, the board can be used as slave (taking power supply) or as master (providing power supply) through the PMODs and the Arduino connectors.

When used as master, the power supply provided to the PMOD host port can be configured to be +3.3 V or +5 V.

Lastly, the external power supply coming from the PMOD peripheral port, the Arduino or the ASi5 connectors, can be directly used as main power source of the +3.3 V or +5 V buses, excluding the internal DC/DC converters.

Because of this flexibility, care must be used when changing the default configuration for selecting different power supplies configurations.

In Figure 3 the power supply chain is shown, together with the different configurations available.

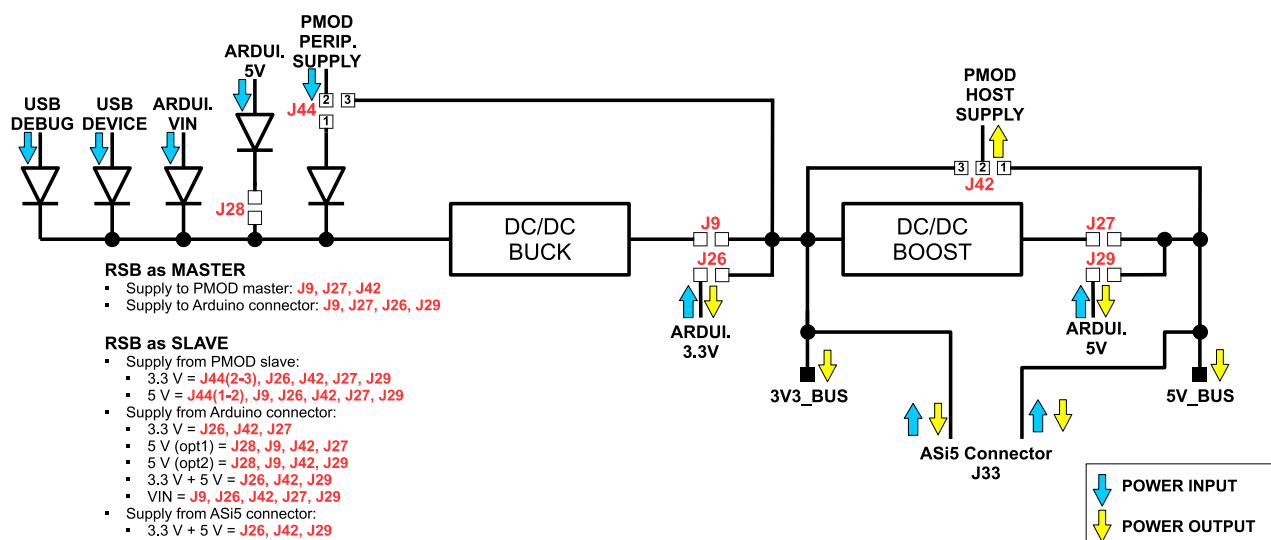

Figure 3: Power supply block diagram.

3. Board Components

In Figure 4 the block diagram of the Multisensorboard is shown.

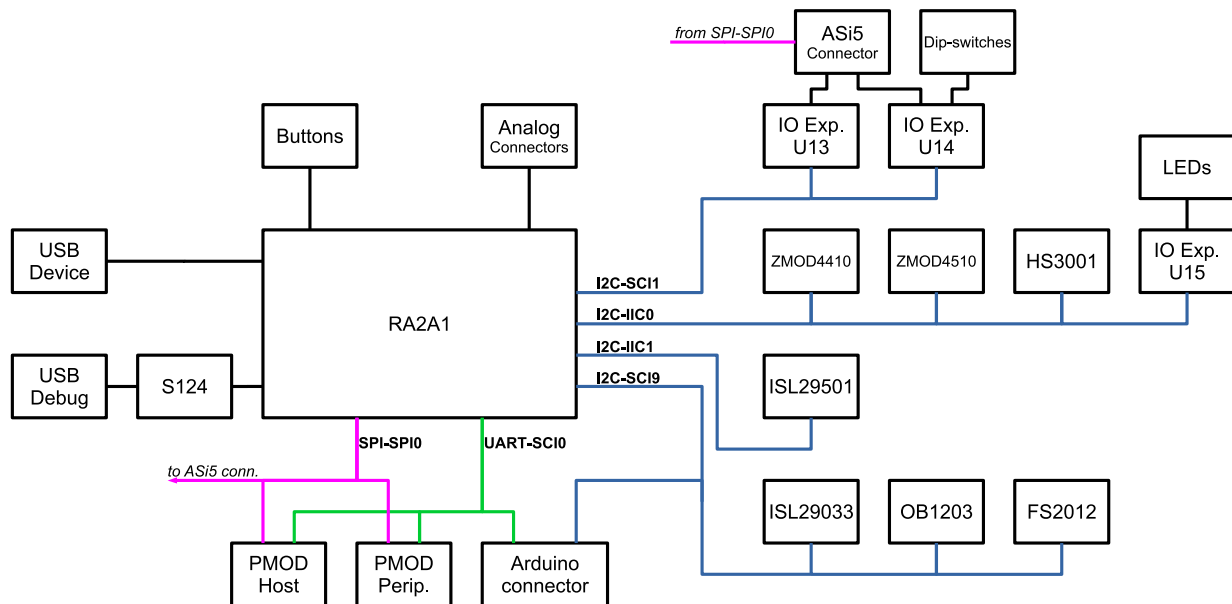

Figure 4: Components blocks diagram.

The RA2A1 is connected to the sensors through I2C buses. There are four I2C buses in order to divide the data traffic and allow the simultaneous use of sensors with the same I2C address.

There is also a UART bus connected to the two PMODs ports (Host and Peripheral) and to the Arduino connector. The PMODs ports are also provided with a SPI bus that is also connected to the ASi5 connector.

To complete the communication interfaces, a micro-USB port (USB Device) is directly connected to the RA2A1.

The other micro-USB present on the board, USB Debug, is connected to the S124 used as debugger/programmer of the main RA2A1 MCU.

Lastly two buttons, SW1 and SW2 (Reset), are present and some analog features are exported on two connectors.

Important notes:

- on PMODs, the SPI and the UART buses share the same pins on the RA2A1 device.
- the SPI0 bus pins on the ASi5 connector are also connected to the IO Expander U14. If the SPI0 is used, make sure that the corresponding pins on the IO Expander are configured as inputs.

3.1 J-Link On-board Debugger

The Renesas S124 MCU is programmed with a SEGGER J-Link® on-board debugger. The debugger is available through the USB Debug port J3.

Alternatively, the 10-pin JTAG connector J1, directly connected to the RA2A1, is available. Remove R3, R4 and R6 for avoiding conflicts with the S124 SEGGER debugger.

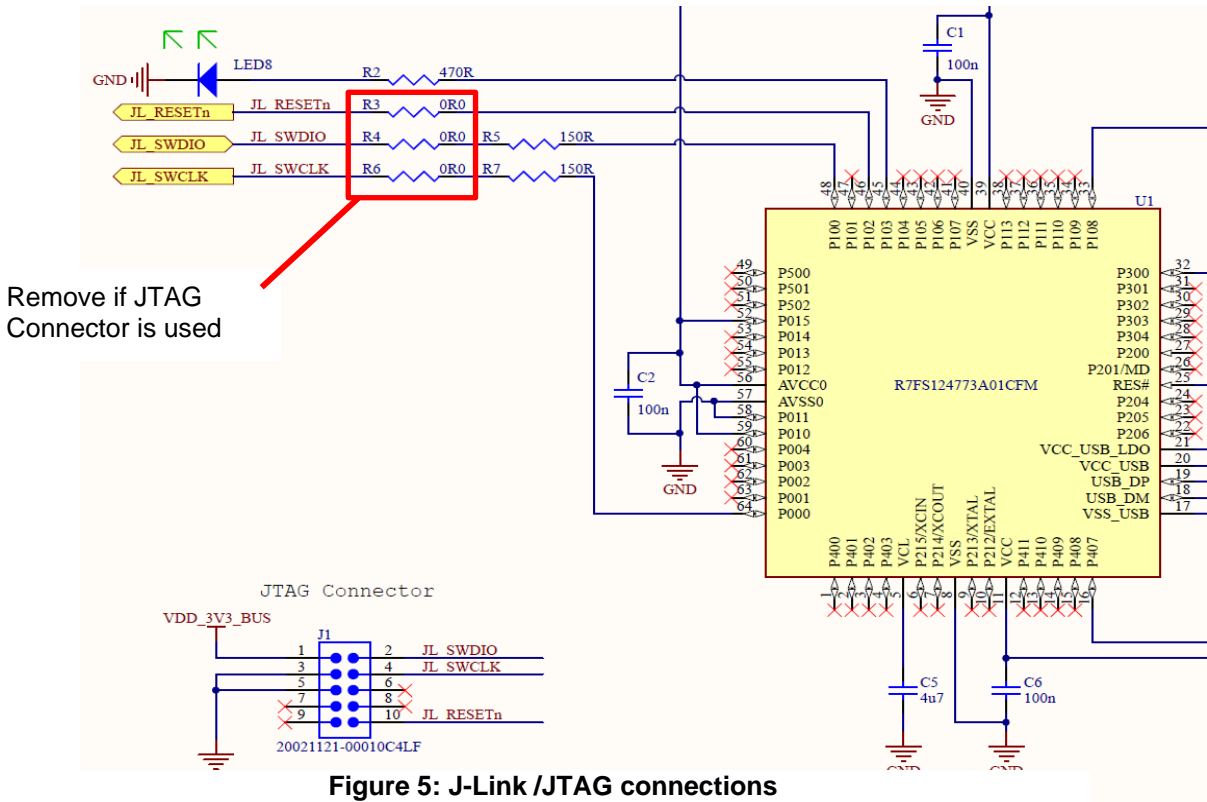

Once the RA2A1 is programmed, the debugger can be disconnected by opening J31 (S124 power supply) and J38 (RA2A1 reset).

3.2 USB Device Port

The USB Device port J8 is directly connected to the RA2A1 MCU.

The +5 V coming from this USB port can be used to supply the board. A diode is present to avoid conflict with other power supply sources.

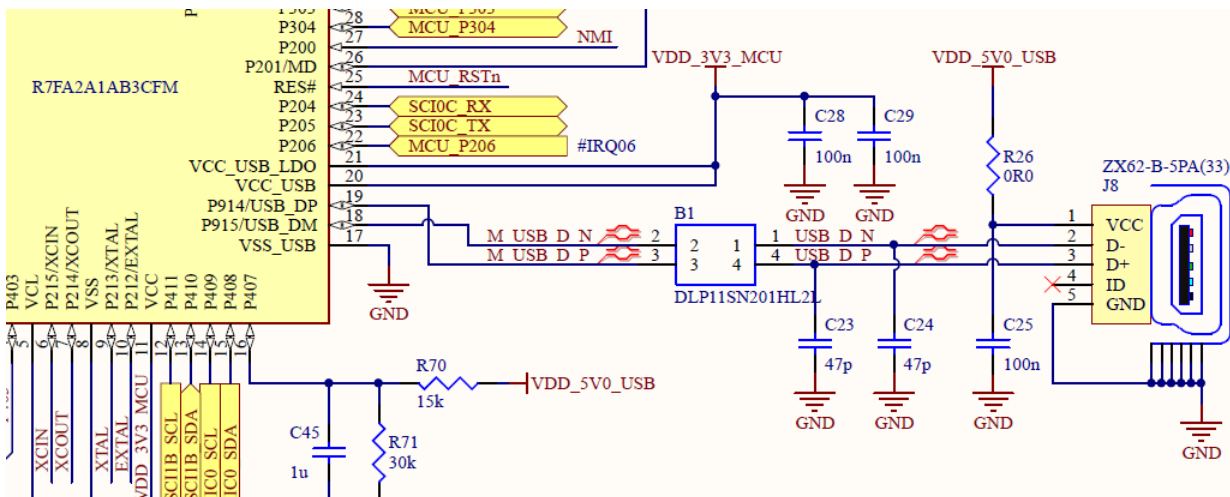

3.3 ASi5 Connector

The pins of the ASi5 connector are connected to the U13 and U14 IO Expanders:

- BIT0-15: IO Expander U13 (I2C address 0x20 on SCI1 bus)
- BIT16-23: IO Expander U14 (I2C address 0x21 on SCI1 bus)

Note that BIT17-20 are also connected to the SPI0 port of the RA2A1 so make sure to not configure both the MCU than the IO Expander pins as outputs at the same time.

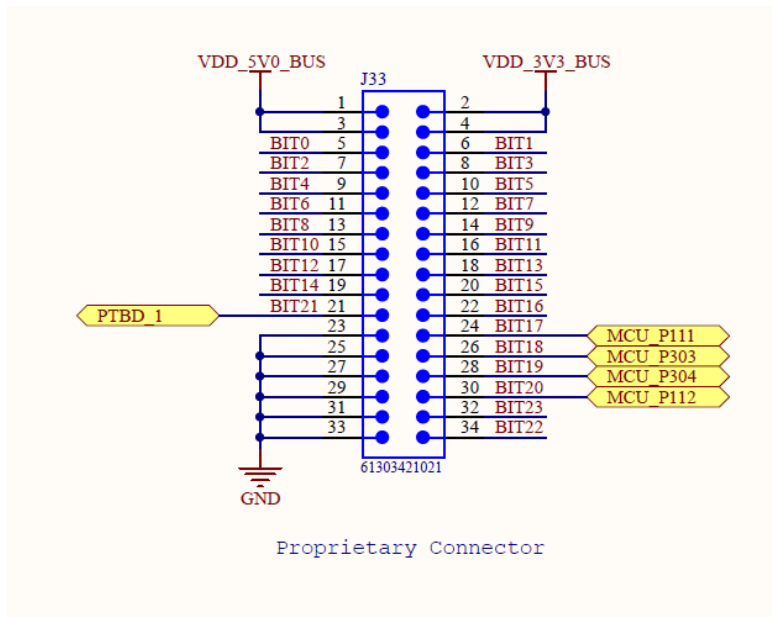

Figure 7: ASi5 Connector.

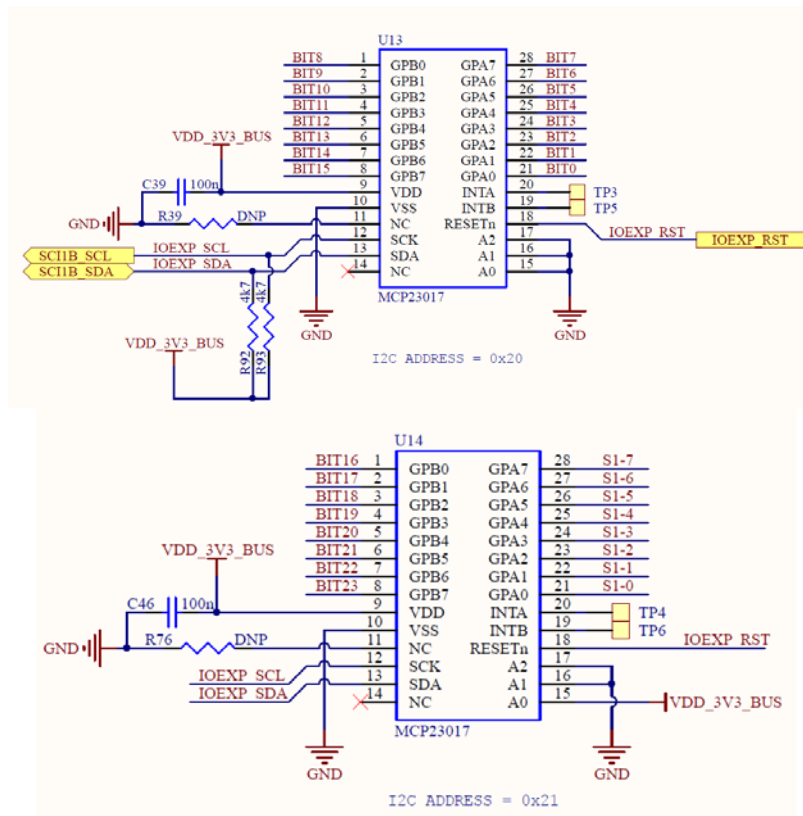

Figure 8: IO Expanders used for the ASi5 connection.

3.4 LEDs, Buttons and Dip-switches

The 8 LEDs available are connected to the A port of the IO Expander U15 (I2C address 0x22 on IIC0 bus), see Figure 9.

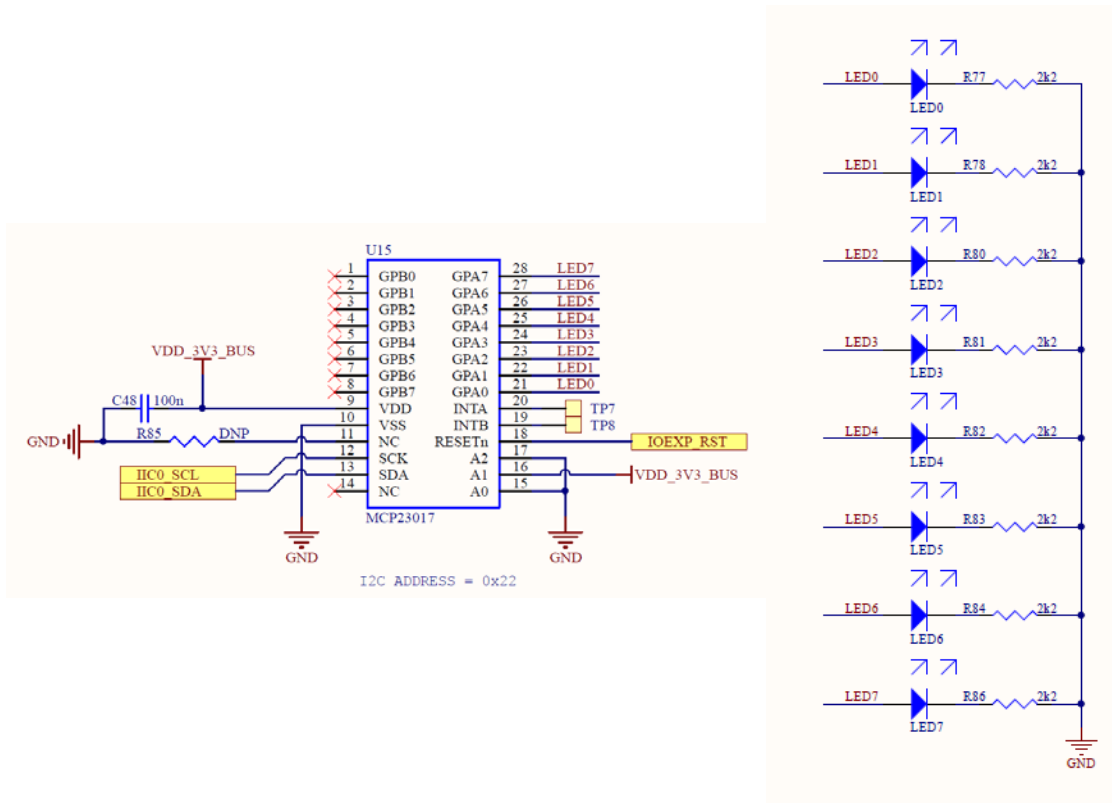

Figure 9: LEDs connection.

As shown in Figure 10, there are 2 push buttons:

- SW1: Used as general-purpose button, connected to the RA2A1 P206 (IRQ06).
- SW2: Used as reset button for the RA2A1. Opening the J38 jumper disconnects the On-Board J-Link Debugger.

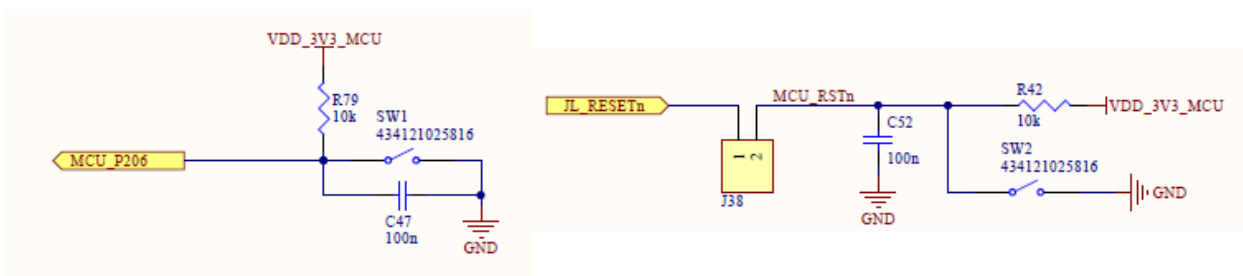

Figure 10: User button SW1 and Reset button SW2.

On the IO Expander U14, also used for the ASi5 connector, are connected 8 dip-switches on the port A. User needs to configure the corresponding pins of the IO Expander as inputs.

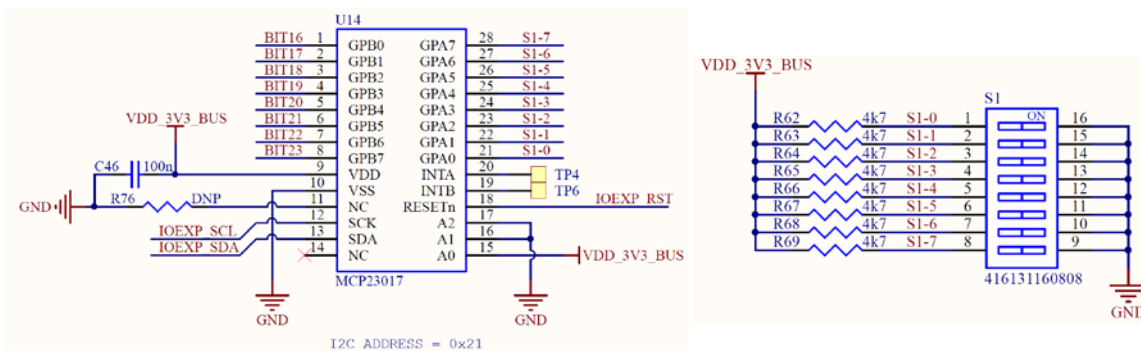

Figure 11: Dip-switches connections.

3.5 PMODs

The Multisensorboard is equipped with two PMOD ports: a host port and a peripheral port.

The ports can be used to communicate with SPI or UART protocols. Note that the Host and the Peripheral ports share the same buses so the same protocol cannot be used on both ports at the same time.

Moreover, the SPI pins are also connected to the ASi5 connector, as showed in Figure 7, and the UART pins are also used in the Arduino connector, see Figure 15.

3.5.1 Host

The Host port J41 can be used to connect external PMOD modules.

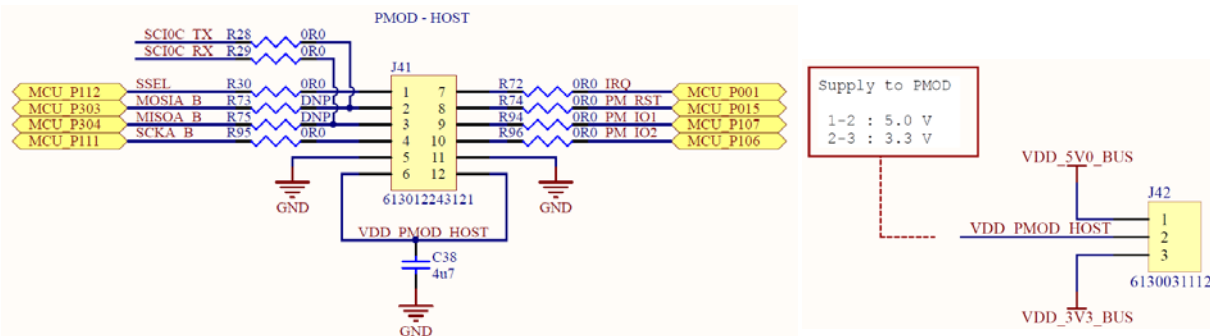

Figure 12: PMOD Host

The UART is the factory default configuration. If the SPI communication is required some 0 Ω resistor should be moved as indicated in Table 1.

Component	UART (default)	SPI
R28	0R0	DNP
R29	0R0	DNP
R73	DNP	0R0
R75	DNP	0R0

Table 1: PMOD Host bus configuration (DNP: Do Not Populate).

The power supply issued to the PMOD host connector can be selected using the J42 connector:

- 3.3 V: jumper between pins 2 and 3 (default).
- 5 V: jumper between pins 1 and 2

3.5.2 Peripheral

Similarly, the Peripheral port J43 can be used to make the Multisensorboard a slave for another board.

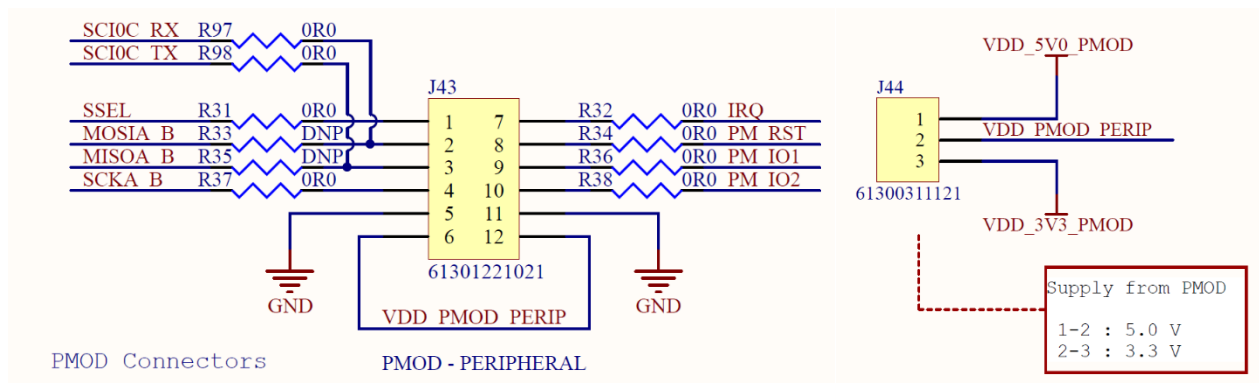

Figure 13: PMOD Peripheral.

Again, the UART is the factory default configuration. If the SPI communication is required, some 0 Ω resistors should be moved as indicated in Table 1.

Component	UART (default)	SPI
R97	0R0	DNP
R98	0R0	DNP
R33	DNP	0R0
R35	DNP	0R0

Table 2: PMOD Peripheral bus configuration (DNP: Do Not Populate).

The board can use the power supply coming from the PMOD Peripheral port, care must be used when using external power supply, refer to section 2 for more information.

As an example, these three main configurations are possible:

- Internal power supply (no power from PMOD Peripheral): no jumpers on J44.
- 3.3 V on PMOD Peripheral port: jumper between pins 2 and 3 of J44, J9 open.
- 5 V on PMOD Peripheral port: jumper between pins 1 and 2 of J44 (default), J9 closed.

3.6 Analog connectors

Some analog functionalities are exported on the two connectors J39 and J40. For more information refer to the RA2A1 User's Manual: Hardware.

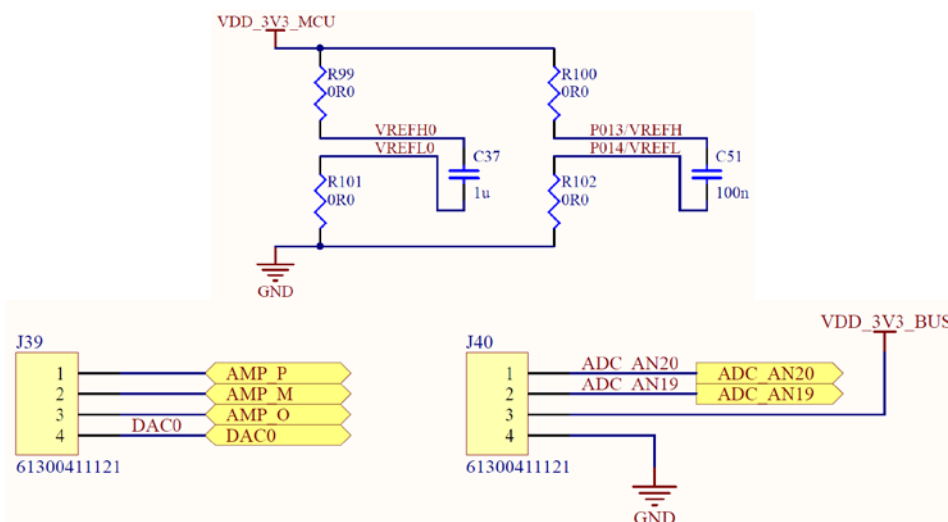

Figure 14: Analog section.

In Figure 14 the power supply references are also reported. The user can use external references removing the 0 Ω resistors.

3.7 Arduino connectors

A standard Arduino connector is also available on the Multisensorboard, Figure 15.

The board can be configured both as host (default) and as shield.

Some notes:

- The power supplies on the connector J5 must be properly configured referring to Figure 3. As default, only VIN is connected to the VDD_IN through a diode.
- The analog section on connector J7 shares the same pins with the analog connector of section 3.6.
- On the connector J4 only the SCI9 pins are connected. The SCI can be configured as I2C or UART.
- On the connector J6, SCI0 is connected to provide a UART port. In order to allow the use of the board as a shield, RX and TX can be swapped as showed in Figure 16.

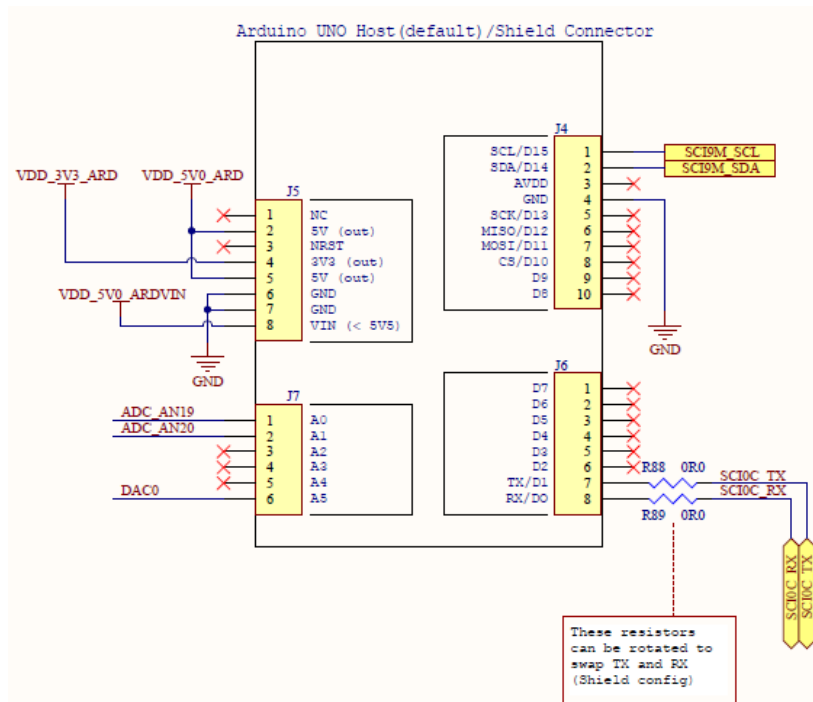

Figure 15: Arduino connector.

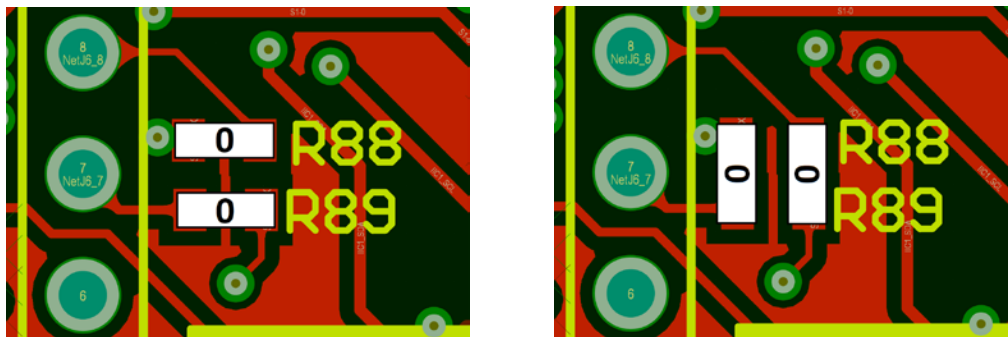

Figure 16: Host (left, default) and Shield (right) UART configuration.

3.8 Sensors

3.8.1 FS2012 - Flow Sensor (not included)

This section of the board includes only the ISL33003 I2C level shifter for interfacing the 3.3 V logic level of the MCU with the 5 V level of the FS2012. On the board only a 90° connector is present, the sensor is not included in the Multisensorboard kit.

This sensor is connected to the SCI9 I2C bus and responds to the I2C address 0x07. An enable (active high) is also required to activate the level shifter.

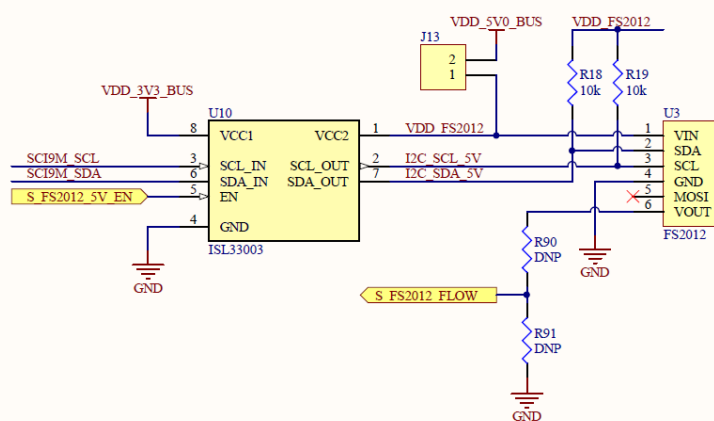

Figure 17: FS2012 section with the level shifter only.

This is the configuration jumper available:

Jumper	Default state	Description
J13	CLOSED	Provide the +5 V power supply to the external sensor connector.

3.8.2 HS3001 - Temperature and Humidity Sensor

This sensor is connected to the IIC0 I2C bus and responds to the I2C address 0x44.

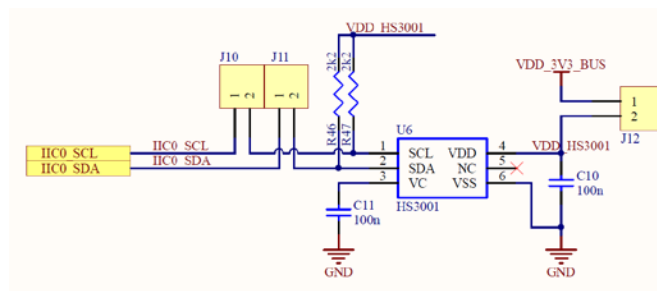

Figure 18: HS3001 section.

These are the configuration jumpers available:

Jumper	Default state	Description
J10	CLOSED	Connect the SCL bus to the HS3001 and provide the pull-up for the IIC0 line.
J11	CLOSED	Connect the SDA bus to the HS3001 and provide the pull-up for the IIC0 line.
J12	CLOSED	Connect the 3.3 V power supply to the HS3001.

3.8.3 ISL29033 - Ambient Light Sensor

This sensor is connected to the SCI9 I2C bus and responds to the I2C address 0x44.

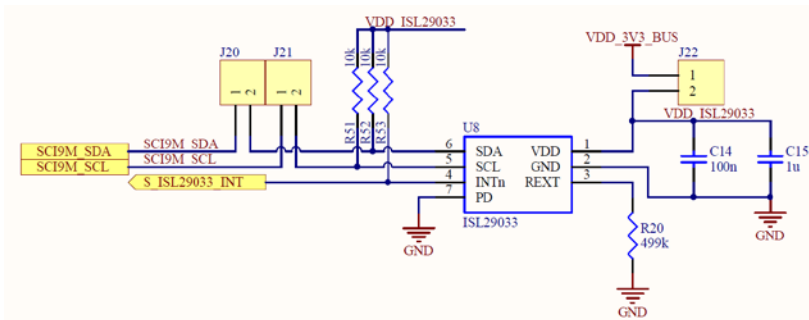

Figure 19: ISL29033 section.

These are the configuration jumpers available:

Jumper	Default state	Description
J20	CLOSED	Connect the SDA bus to the ISL29033 and provide the pull-up for the SCI9 line.
J21	CLOSED	Connect the SCL bus to the ISL29033 and provide the pull-up for the SCI9 line.
J22	CLOSED	Connect the 3.3 V power supply to the ISL29033.

3.8.4 ISL29501 - Time of Flight Sensor

This sensor is connected to the IIC1 I2C bus and responds to the I2C address 0x57.

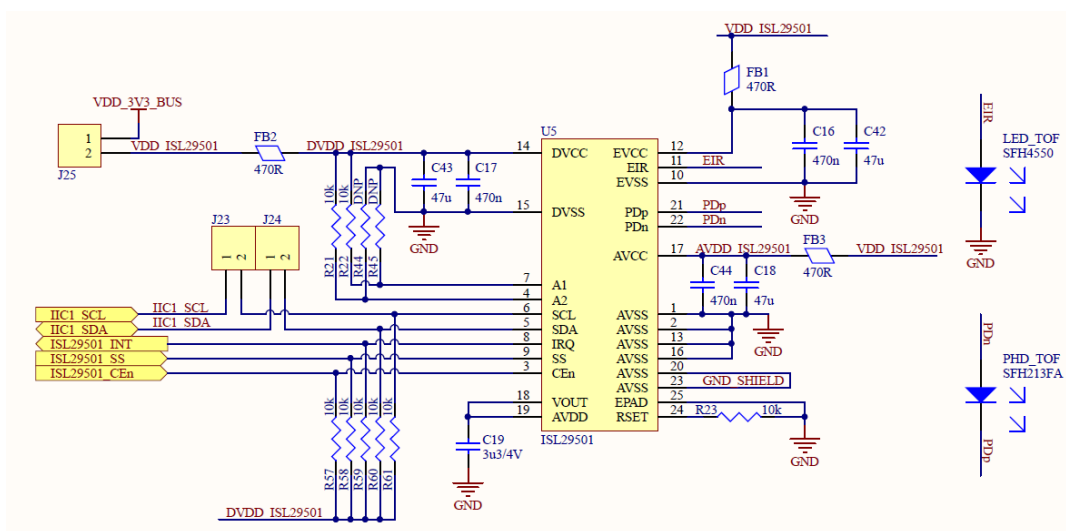

Figure 20: ISL29501 section.

Jumper	Default state	Description
J23	CLOSED	Connect the SCL bus to the ISL29501 and provide the pull-up for the IIC1 line.
J24	CLOSED	Connect the SDA bus to the ISL29501 and provide the pull-up for the IIC1 line.

J25	CLOSED	Connect the 3.3 V power supply to the ISL29501.
-----	--------	---

These are the configuration jumpers available:

3.8.5 OB1203 - Digital RGB / Ambient Light, Proximity and Photoplethysmography Sensor

This sensor is connected to the SCI9 I2C bus and responds to the I2C address 0x53.

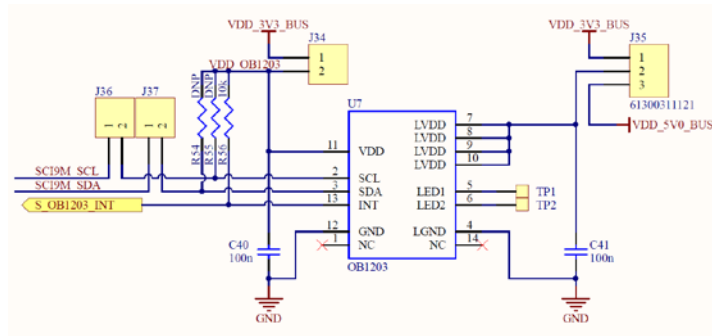

Figure 21: OB1203 section.

These are the configuration jumpers available:

Jumper	Default state	Description
J34	CLOSED	Connect the 3.3 V power supply to the OB1203.
J35	CLOSED	Connect the 3.3 V or the 5 V power supply to the power section of the OB1203.
J36	CLOSED	Connect the SCL bus to the OB1203.
J37	CLOSED	Connect the SDA bus to the OB1203.

3.8.6 ZMOD4410 - Gas Sensor Module for TVOC and Indoor Air Quality Sensor

This sensor is connected to the IIC0 I2C bus and responds to the I2C address 0x32.

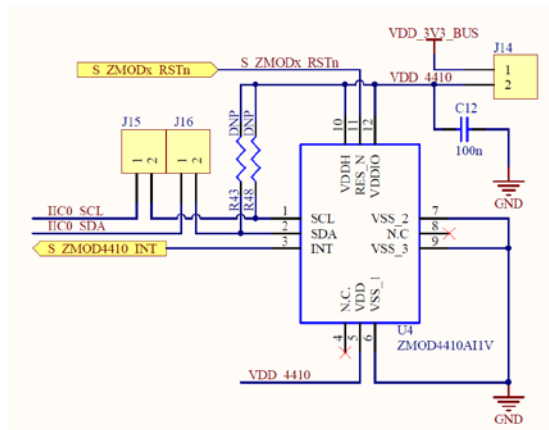

Figure 22: ZMOD4410 section.

These are the configuration jumpers available:

Jumper	Default state	Description
J14	CLOSED	Connect the 3.3 V power supply to the ZMOD4410.
J15	CLOSED	Connect the SCL bus to the ZMOD4410.
J16	CLOSED	Connect the SDA bus to the ZMOD4410.

3.8.7 ZMOD4510 - Gas Sensor Module for Outdoor Air Quality sensor

This sensor is connected to the IIC0 I2C bus and responds to the I2C address 0x33.

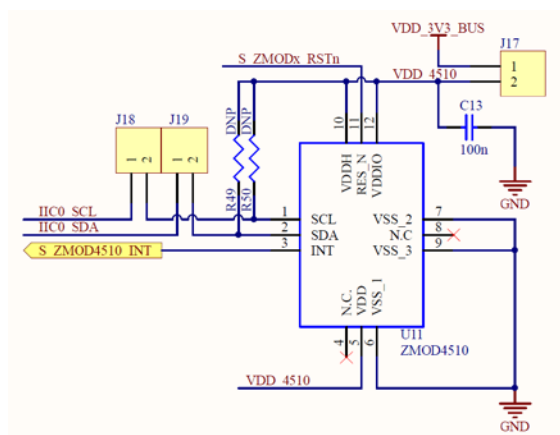

Figure 23: ZMOD4510 section.

These are the configuration jumpers available:

Jumper	Default state	Description
J17	CLOSED	Connect the 3.3 V power supply to the ZMOD4510.
J18	CLOSED	Connect the SCL bus to the ZMOD4510.
J19	CLOSED	Connect the SDA bus to the ZMOD4510.

4. Board Layout

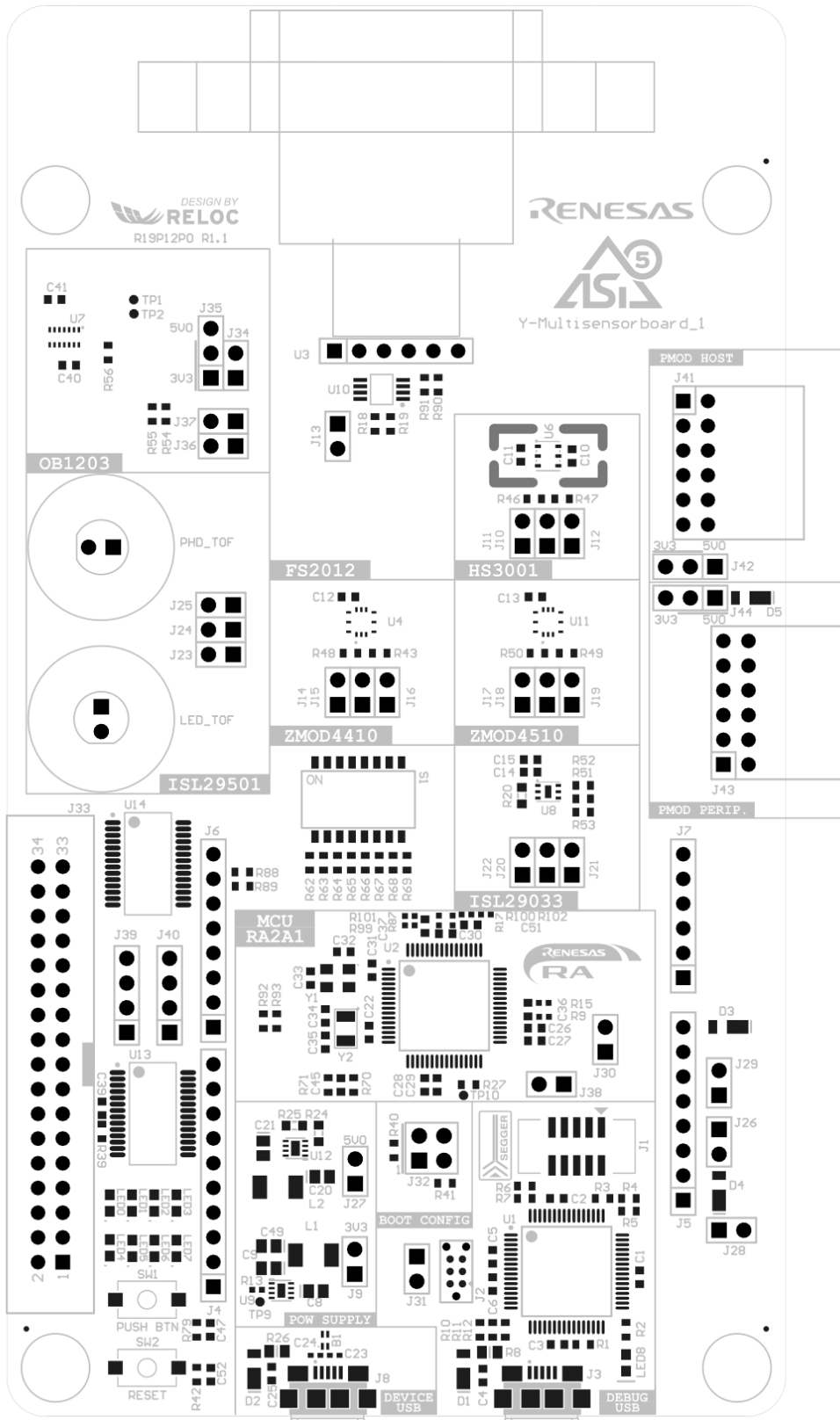

Figure 24: Top side.

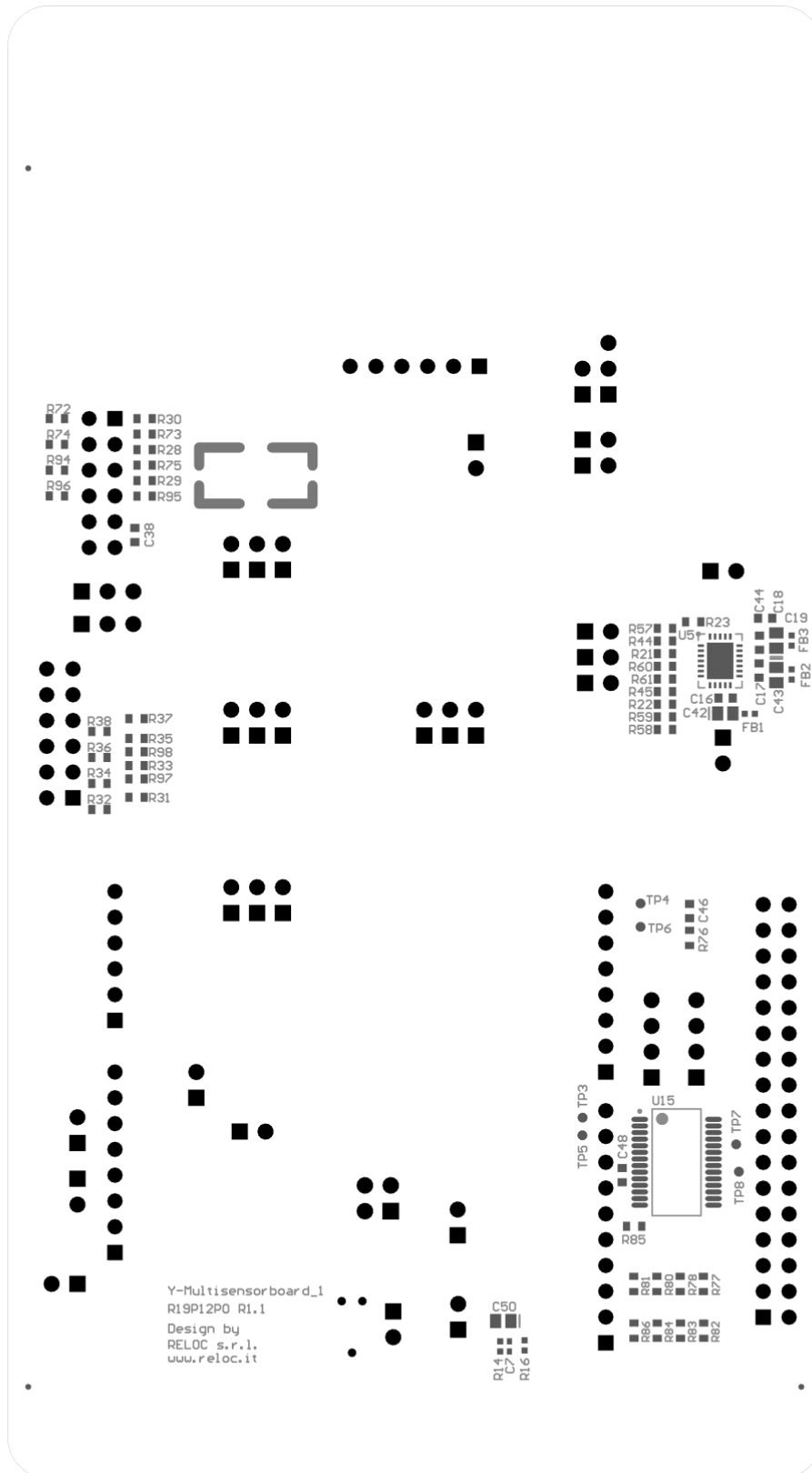

Figure 25: Bottom side.

References

- [1] Renesas Electronics, "Multisensorboard – Software User's Guide".
- [2] Renesas Electronics, "Multisensorboard – Quick Start Guide".
- [3] Renesas Electronics, "Renesas RA2A1 Group - User's Manual: Hardware" Oct. 2019 - R01UH0888EJ0100: [Link](#).
- [4] Renesas Electronics, "FS2012 Series Datasheet - High Performance Flow Sensor Module", Aug. 24, 2018: [Link](#).
- [5] Renesas Electronics (IDT), "HS300x Datasheet - High Performance Relative Humidity and Temperature Sensor", Aug. 6, 2018: [Link](#).
- [6] Renesas Electronics, "ISL29033 Datasheet - Ultra-Low Lux, Low Power, Integrated Digital Ambient Light Sensor with Interrupt Function", Rev 5.00 Sep. 28, 2016: [Link](#).
- [7] Renesas Electronics, "ISL29501 Datasheet - Time of Flight (ToF) Signal Processing IC", May. 5, 2017: [Link](#).
- [8] Renesas Electronics, "ISL29501 AN1724 – Firmware Routines", Rev 1.00 Mar. 31, 2017: [Link](#).
- [9] Renesas Electronics (IDT), "OB1203 Preliminary Datasheet - Digital RGB / Ambient Light, Proximity and Photoplethysmography Sensor", Mar. 6, 2019: [Link](#).
- [10] Renesas Electronics (IDT), "ZMOD4410 Datasheet - Gas Sensor Module for TVOC and Indoor Air Quality", Jul. 30, 2019: [Link](#).
- [11] Renesas Electronics (IDT), "ZMOD4510 Datasheet - Gas Sensor Module for Outdoor Air Quality", Sep. 9, 2019: [Link](#).

Revision History

Rev.	Date	Description	
		Page	Summary
0.01	16 Mar 2020		Initial version.
0.02	23 Mar 2020		Added References. Added short overview do blocks diagram. Added complete schematics.
0.03	25 Mar 2020		Renesas feedback corrections.
0.04	09 Apr 2020		Added ASI5 connector as power supply source.
01.00	03 Sept 2020		Added document # R30AN0362ED0100

General Precautions in the Handling of Microprocessing Unit and Microcontroller Unit Products

The following usage notes are applicable to all Microprocessing unit and Microcontroller unit products from Renesas. For detailed usage notes on the products covered by this document, refer to the relevant sections of the document as well as any technical updates that have been issued for the products.

1. Precaution against Electrostatic Discharge (ESD)

A strong electrical field, when exposed to a CMOS device, can cause destruction of the gate oxide and ultimately degrade the device operation. Steps must be taken to stop the generation of static electricity as much as possible, and quickly dissipate it when it occurs. Environmental control must be adequate. When it is dry, a humidifier should be used. This is recommended to avoid using insulators that can easily build up static electricity.

Semiconductor devices must be stored and transported in an anti-static container, static shielding bag or conductive material. All test and measurement tools including work benches and floors must be grounded. The operator must also be grounded using a wrist strap. Semiconductor devices must not be touched with bare hands. Similar precautions must be taken for printed circuit boards with mounted semiconductor devices.

2. Processing at power-on

The state of the product is undefined at the time when power is supplied. The states of internal circuits in the LSI are indeterminate and the states of register settings and pins are undefined at the time when power is supplied. In a finished product where the reset signal is applied to the external reset pin, the states of pins are not guaranteed from the time when power is supplied until the reset process is completed. In a similar way, the states of pins in a product that is reset by an on-chip power-on reset function are not guaranteed from the time when power is supplied until the power reaches the level at which resetting is specified.

3. Input of signal during power-off state

Do not input signals or an I/O pull-up power supply while the device is powered off. The current injection that results from input of such a signal or I/O pull-up power supply may cause malfunction and the abnormal current that passes in the device at this time may cause degradation of internal elements. Follow the guideline for input signal during power-off state as described in your product documentation.

4. Handling of unused pins

Handle unused pins in accordance with the directions given under handling of unused pins in the manual. The input pins of CMOS products are generally in the high-impedance state. In operation with an unused pin in the open-circuit state, extra electromagnetic noise is induced in the vicinity of the LSI, an associated shoot-through current flows internally, and malfunctions occur due to the false recognition of the pin state as an input signal become possible.

5. Clock signals

After applying a reset, only release the reset line after the operating clock signal becomes stable. When switching the clock signal during program execution, wait until the target clock signal is stabilized. When the clock signal is generated with an external resonator or from an external oscillator during a reset, ensure that the reset line is only released after full stabilization of the clock signal. Additionally, when switching to a clock signal produced with an external resonator or by an external oscillator while program execution is in progress, wait until the target clock signal is stable.

6. Voltage application waveform at input pin

Waveform distortion due to input noise or a reflected wave may cause malfunction. If the input of the CMOS device stays in the area between V_{IL} (Max.) and V_{IH} (Min.) due to noise, for example, the device may malfunction. Take care to prevent chattering noise from entering the device when the input level is fixed, and also in the transition period when the input level passes through the area between V_{IL} (Max.) and V_{IH} (Min.).

7. Prohibition of access to reserved addresses

Access to reserved addresses is prohibited. The reserved addresses are provided for possible future expansion of functions. Do not access these addresses as the correct operation of the LSI is not guaranteed.

8. Differences between products

Before changing from one product to another, for example to a product with a different part number, confirm that the change will not lead to problems. The characteristics of a microprocessing unit or microcontroller unit products in the same group but having a different part number might differ in terms of internal memory capacity, layout pattern, and other factors, which can affect the ranges of electrical characteristics, such as characteristic values, operating margins, immunity to noise, and amount of radiated noise. When changing to a product with a different part number, implement a system-evaluation test for the given product.

Notice

1. Descriptions of circuits, software and other related information in this document are provided only to illustrate the operation of semiconductor products and application examples. You are fully responsible for the incorporation or any other use of the circuits, software, and information in the design of your product or system. Renesas Electronics disclaims any and all liability for any losses and damages incurred by you or third parties arising from the use of these circuits, software, or information.
 2. Renesas Electronics hereby expressly disclaims any warranties against and liability for infringement or any other claims involving patents, copyrights, or other intellectual property rights of third parties, by or arising from the use of Renesas Electronics products or technical information described in this document, including but not limited to, the product data, drawings, charts, programs, algorithms, and application examples.
 3. No license, express, implied or otherwise, is granted hereby under any patents, copyrights or other intellectual property rights of Renesas Electronics or others.
 4. You shall not alter, modify, copy, or reverse engineer any Renesas Electronics product, whether in whole or in part. Renesas Electronics disclaims any and all liability for any losses or damages incurred by you or third parties arising from such alteration, modification, copying or reverse engineering.
 5. Renesas Electronics products are classified according to the following two quality grades: "Standard" and "High Quality". The intended applications for each Renesas Electronics product depends on the product's quality grade, as indicated below.
 - "Standard": Computers; office equipment; communications equipment; test and measurement equipment; audio and visual equipment; home electronic appliances; machine tools; personal electronic equipment; industrial robots; etc.
 - "High Quality": Transportation equipment (automobiles, trains, ships, etc.); traffic control (traffic lights); large-scale communication equipment; key financial terminal systems; safety control equipment; etc.
- Unless expressly designated as a high reliability product or a product for harsh environments in a Renesas Electronics data sheet or other Renesas Electronics document, Renesas Electronics products are not intended or authorized for use in products or systems that may pose a direct threat to human life or bodily injury (artificial life support devices or systems; surgical implantations; etc.), or may cause serious property damage (space system; undersea repeaters; nuclear power control systems; aircraft control systems; key plant systems; military equipment; etc.). Renesas Electronics disclaims any and all liability for any damages or losses incurred by you or any third parties arising from the use of any Renesas Electronics product that is inconsistent with any Renesas Electronics data sheet, user's manual or other Renesas Electronics document.
6. When using Renesas Electronics products, refer to the latest product information (data sheets, user's manuals, application notes, "General Notes for Handling and Using Semiconductor Devices" in the reliability handbook, etc.), and ensure that usage conditions are within the ranges specified by Renesas Electronics with respect to maximum ratings, operating power supply voltage range, heat dissipation characteristics, installation, etc. Renesas Electronics disclaims any and all liability for any malfunctions, failure or accident arising out of the use of Renesas Electronics products outside of such specified ranges.
 7. Although Renesas Electronics endeavors to improve the quality and reliability of Renesas Electronics products, semiconductor products have specific characteristics, such as the occurrence of failure at a certain rate and malfunctions under certain use conditions. Unless designated as a high reliability product or a product for harsh environments in a Renesas Electronics data sheet or other Renesas Electronics document, Renesas Electronics products are not subject to radiation resistance design. You are responsible for implementing safety measures to guard against the possibility of bodily injury, injury or damage caused by fire, and/or danger to the public in the event of a failure or malfunction of Renesas Electronics products, such as safety design for hardware and software, including but not limited to redundancy, fire control and malfunction prevention, appropriate treatment for aging degradation or any other appropriate measures. Because the evaluation of microcomputer software alone is very difficult and impractical, you are responsible for evaluating the safety of the final products or systems manufactured by you.
 8. Please contact a Renesas Electronics sales office for details as to environmental matters such as the environmental compatibility of each Renesas Electronics product. You are responsible for carefully and sufficiently investigating applicable laws and regulations that regulate the inclusion or use of controlled substances, including without limitation, the EU RoHS Directive, and using Renesas Electronics products in compliance with all these applicable laws and regulations. Renesas Electronics disclaims any and all liability for damages or losses occurring as a result of your noncompliance with applicable laws and regulations.
 9. Renesas Electronics products and technologies shall not be used for or incorporated into any products or systems whose manufacture, use, or sale is prohibited under any applicable domestic or foreign laws or regulations. You shall comply with any applicable export control laws and regulations promulgated and administered by the governments of any countries asserting jurisdiction over the parties or transactions.
 10. It is the responsibility of the buyer or distributor of Renesas Electronics products, or any other party who distributes, disposes of, or otherwise sells or transfers the product to a third party, to notify such third party in advance of the contents and conditions set forth in this document.
 11. This document shall not be reprinted, reproduced or duplicated in any form, in whole or in part, without prior written consent of Renesas Electronics.
 12. Please contact a Renesas Electronics sales office if you have any questions regarding the information contained in this document or Renesas Electronics products.

(Note1) "Renesas Electronics" as used in this document means Renesas Electronics Corporation and also includes its directly or indirectly controlled subsidiaries.

(Note2) "Renesas Electronics product(s)" means any product developed or manufactured by or for Renesas Electronics.

(Rev.4.0-1 November 2017)

Corporate Headquarters

TOYOSU FORESIA, 3-2-24 Toyosu,
Koto-ku, Tokyo 135-0061, Japan
www.renesas.com

Trademarks

Renesas and the Renesas logo are trademarks of Renesas Electronics Corporation. All trademarks and registered trademarks are the property of their respective owners.

Contact information

For further information on a product, technology, the most up-to-date version of a document, or your nearest sales office, please visit:
www.renesas.com/contact/.