

ISL5314EVAL2

Evaluation Board

AN9909
Rev.2.00
September 2001

Description

The ISL5314EVAL2 provides a means of evaluating the Intersil ISL5314, 125MSPS, Direct Digital Synthesizer (DDS). The board is controlled with software that allows for any clock frequency and output frequency within the abilities of the ISL5314 to be evaluated. The interface between the PC and the evaluation board is via the parallel port of an IBM compatible PC. The analog output of the DDS can be analyzed on external measuring equipment; typically either a spectrum analyzer or an oscilloscope. The clock source for the DDS can either be a user-changeable crystal or an external signal generator provided through an SMA connector. The board is shipped with a 125MSPS crystal. The complementary analog outputs of the DDS are processed through a 1:1 transformer. The board can be reconfigured to bypass the transformer and only a single-ended output used. Because there is an on-chip comparator, the means to process the analog sinewave from the DDS output into the comparator inputs is provided for square wave generation. The comparator's output is provided via an SMA connector. Consult the data sheet of the ISL5314 for details of the DDS's capabilities.

Features

- GUI software control via parallel port
- Clock: On-board crystal socket or externally applied
- 1:1 RF transformer for analog output

Ordering Information

PART NUMBER	PACKAGE
ISL5314EVAL2	Evaluation Board

Evaluation Board Block Diagram

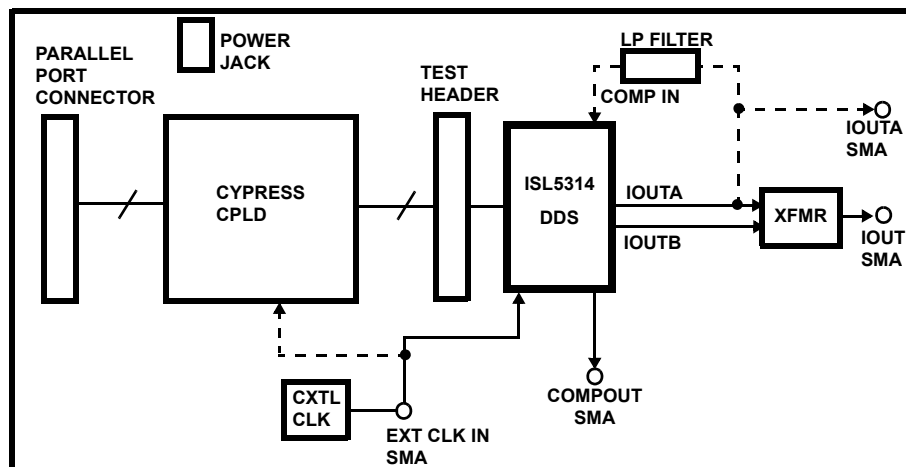

Getting Started

The ISL5314EVAL2 is relatively easy to operate. The required equipment is as follows:

1. ISL5314EVAL2 evaluation board
2. Printer extension cable (DB25 male to female)
3. Clock source, either crystal or signal generator
4. Latest version of the software
5. 5V/500mA power supply
6. 1 RF cable with an SMA connector
7. Spectrum analyzer or oscilloscope

Software Download

Regardless of the version of the software that is shipped with the board, it is recommended that the user obtain the latest version. Go to www.intersil.com and do a product datasheet search on the ISL5314. Select the link to the ISL5314IN. In the related documents section, select the link to the DDS software. The link will download an installation program. Run the installation. Follow the instructions on the screen. After the program is installed, it will automatically run the software. If the computer has a non-NT based operating system, the software should work immediately, provided the parallel port address on the Board panel of the software is correct (default is 378). If the operating system is NT based, it is likely that the user will need to close the DDS software, find the directory in which it was installed (default is c:\ISL5314EVAL2), and run the port95nt.exe program once. After restarting the computer, run the ISL5314x.exe software located in the directory selected during installation. Once the port95nt.exe program is run on a computer, it should not have to be executed a second time.

Setup Instructions

Verify the following board jumper settings:

J2 (OPEN) - crystal enabled

J3 (OPEN) - 50Ω Load for external clock disabled

J7 (OPEN) - CPLD programming disabled

J37 (SHORT) - internal DAC reference enabled

The board is shipped with a 125MHz crystal clock source included. To confirm that the board is working properly, it is recommended that the user leave the crystal in place and the jumper settings as previously listed. After confirmation that the board is working properly, the user can change the clock source.

To begin, connect the included printer cable between the IBM-compatible PC and J6 of the evaluation board. Connect a coaxial cable between J11 (IOUT) and either a spectrum analyzer or an oscilloscope. The input impedance of the measurement equipment should be 50Ω. Connect the power cable to the power jack (J14) and to a 5V power supply. Turn on the power supply. Proceed to the *Software Instructions*.

Software Instructions

If the directions in *Software Download* have not been completed, go back and complete before proceeding.

With the board powered up and connected to the PC via the parallel port, launch the DDS software. The DDS software has three control tabs. On the 'Board' tab of the software, the 'Parallel Control Bus' must be checked before the software will communicate with the eval board. Use the 'DDS Options' tab to configure the part for different operating modes.

The tabs contain default settings the first time the software is executed. It remembers most previous settings every subsequent time it is executed. The first time the program is executed, the clock and center frequencies will be zero. On the front panel, the user should type '125M' into the clock frequency text box and hit the ENTER key. Mouse-click on the 'Soft Reset' button. This should default the center frequency register to $\frac{1}{4}$ of the clock frequency. Verify on the measurement equipment that there is a sinewave at 31.25MHz coming from J11 on the evaluation board. Once this has been verified, the user should change the center frequency to something else (maximum output frequency is $\frac{1}{2}$ the DDS clock rate). To change the center frequency, type a different frequency (i.e., '5M') into the center frequency register and hit the ENTER key. Or, change the center frequency register in hexadecimal format by typing a new value into one of the hexadecimal text boxes labeled 'center frequency register.' The format is 0x00, where 0x is a constant prefix. The analog output of the DDS should now be 5MHz, or whatever was programmed.

A 'step size' input box is located under both the center and offset frequency input boxes. The purpose of this box is for the user to be able to set a step size and then quickly evaluate a

range of output frequencies by hitting the up and down arrows on their keyboard, or by mouse-clicking the arrows next to the 'step size' boxes.

Changing the Board Configuration

To drive the DDS with an external clock source, remove the oscillator (U1), or install jumper J2 which will disable the crystal. Drive the external clock into J8. Install J3 so that the external signal source will be loaded with 50Ω on the evaluation board. Change the 'Clock Frequency' text box on the front panel of the software to match the actual frequency used.

The board is normally configured for differential-to-single-ended output with transformer coupling (J11). For single-ended loading using IOUTA (J10), install a 0Ω resistor at R48 and remove J5 and J15 next to the transformer, as well as R45 and R46. Ensure that R19 and J40 are not populated, and that R43 is populated with a resistor that does not violate the output voltage compliance range (typically 50Ω).

Performance Notes

1. Lab testing has shown that the transformer has little or no benefit to the harmonic performance of the analog output. This is due to a mismatch in IOUTA and IOUTB. For a more cost effective solution, the user may decide to use the single-ended configuration (IOUTA or IOUTB), which is simply to put a resistor between IOUTA and ground that forms a voltage with the current output of the DDS. The maximum output current is +20mA. A 50Ω load with full scale current will be a +1V signal. The maximum output voltage of the DDS is +1.25V. The output current is set with R41 (RSET). See data sheet for details.
2. Using a +5V supply for both the digital and analog supplies of the DDS can improve the SFDR, compared to using a +3.3V digital and +5V analog.
3. For applications that can provide a +5V supply for both the digital and analog (DVDD and AVDD) supplies of the DDS, the SFDR can be improved by connecting the COMP2 pin of the DDS to AVDD directly. This is especially true for 'DDS CLK-to-analog output frequency' ratios that are less than 4 (100M clock, 30MHz output, for example). For ratios greater than 4, this method has little effect. This cannot be done unless DVDD = AVDD = +5V. The evaluation board was not configured for this option, but a simple wire jumper can be used to prove or disprove its effectiveness. The user may wish to build this option into their system in the event that it improves the harmonic performance during evaluation.
4. The maximum DDS clock rate is 125MSPS with a +5V digital supply. The maximum DDS clock rate with a +3.3V digital supply is 100MSPS.

Schematics and Board Plots

The board schematic and layout can be found on the Intersil website by doing a product search on ISL5314 and selecting the link to the ISL5314IN.

Notice

1. Descriptions of circuits, software and other related information in this document are provided only to illustrate the operation of semiconductor products and application examples. You are fully responsible for the incorporation or any other use of the circuits, software, and information in the design of your product or system. Renesas Electronics disclaims any and all liability for any losses and damages incurred by you or third parties arising from the use of these circuits, software, or information.
2. Renesas Electronics hereby expressly disclaims any warranties against and liability for infringement or any other claims involving patents, copyrights, or other intellectual property rights of third parties, by or arising from the use of Renesas Electronics products or technical information described in this document, including but not limited to, the product data, drawings, charts, programs, algorithms, and application examples.
3. No license, express, implied or otherwise, is granted hereby under any patents, copyrights or other intellectual property rights of Renesas Electronics or others.
4. You shall not alter, modify, copy, or reverse engineer any Renesas Electronics product, whether in whole or in part. Renesas Electronics disclaims any and all liability for any losses or damages incurred by you or third parties arising from such alteration, modification, copying or reverse engineering.
5. Renesas Electronics products are classified according to the following two quality grades: "Standard" and "High Quality". The intended applications for each Renesas Electronics product depends on the product's quality grade, as indicated below.
"Standard": Computers; office equipment; communications equipment; test and measurement equipment; audio and visual equipment; home electronic appliances; machine tools; personal electronic equipment; industrial robots; etc.
"High Quality": Transportation equipment (automobiles, trains, ships, etc.); traffic control (traffic lights); large-scale communication equipment; key financial terminal systems; safety control equipment; etc.
Unless expressly designated as a high reliability product or a product for harsh environments in a Renesas Electronics data sheet or other Renesas Electronics document, Renesas Electronics products are not intended or authorized for use in products or systems that may pose a direct threat to human life or bodily injury (artificial life support devices or systems; surgical implantations; etc.), or may cause serious property damage (space system; undersea repeaters; nuclear power control systems; aircraft control systems; key plant systems; military equipment; etc.). Renesas Electronics disclaims any and all liability for any damages or losses incurred by you or any third parties arising from the use of any Renesas Electronics product that is inconsistent with any Renesas Electronics data sheet, user's manual or other Renesas Electronics document.
6. When using Renesas Electronics products, refer to the latest product information (data sheets, user's manuals, application notes, "General Notes for Handling and Using Semiconductor Devices" in the reliability handbook, etc.), and ensure that usage conditions are within the ranges specified by Renesas Electronics with respect to maximum ratings, operating power supply voltage range, heat dissipation characteristics, installation, etc. Renesas Electronics disclaims any and all liability for any malfunctions, failure or accident arising out of the use of Renesas Electronics products outside of such specified ranges.
7. Although Renesas Electronics endeavors to improve the quality and reliability of Renesas Electronics products, semiconductor products have specific characteristics, such as the occurrence of failure at a certain rate and malfunctions under certain use conditions. Unless designated as a high reliability product or a product for harsh environments in a Renesas Electronics data sheet or other Renesas Electronics document, Renesas Electronics products are not subject to radiation resistance design. You are responsible for implementing safety measures to guard against the possibility of bodily injury, injury or damage caused by fire, and/or danger to the public in the event of a failure or malfunction of Renesas Electronics products, such as safety design for hardware and software, including but not limited to redundancy, fire control and malfunction prevention, appropriate treatment for aging degradation or any other appropriate measures. Because the evaluation of microcomputer software alone is very difficult and impractical, you are responsible for evaluating the safety of the final products or systems manufactured by you.
8. Please contact a Renesas Electronics sales office for details as to environmental matters such as the environmental compatibility of each Renesas Electronics product. You are responsible for carefully and sufficiently investigating applicable laws and regulations that regulate the inclusion or use of controlled substances, including without limitation, the EU RoHS Directive, and using Renesas Electronics products in compliance with all these applicable laws and regulations. Renesas Electronics disclaims any and all liability for damages or losses occurring as a result of your noncompliance with applicable laws and regulations.
9. Renesas Electronics products and technologies shall not be used for or incorporated into any products or systems whose manufacture, use, or sale is prohibited under any applicable domestic or foreign laws or regulations. You shall comply with any applicable export control laws and regulations promulgated and administered by the governments of any countries asserting jurisdiction over the parties or transactions.
10. It is the responsibility of the buyer or distributor of Renesas Electronics products, or any other party who distributes, disposes of, or otherwise sells or transfers the product to a third party, to notify such third party in advance of the contents and conditions set forth in this document.
11. This document shall not be reprinted, reproduced or duplicated in any form, in whole or in part, without prior written consent of Renesas Electronics.
12. Please contact a Renesas Electronics sales office if you have any questions regarding the information contained in this document or Renesas Electronics products.
(Note 1) "Renesas Electronics" as used in this document means Renesas Electronics Corporation and also includes its directly or indirectly controlled subsidiaries.
(Note 2) "Renesas Electronics product(s)" means any product developed or manufactured by or for Renesas Electronics.

(Rev.4.0-1 November 2017)



SALES OFFICES

Renesas Electronics Corporation

<http://www.renesas.com>

Refer to "<http://www.renesas.com/>" for the latest and detailed information.

Renesas Electronics America Inc.
1001 Murphy Ranch Road, Milpitas, CA 95035, U.S.A.
Tel: +1-408-432-8888, Fax: +1-408-434-5351

Renesas Electronics Canada Limited
9251 Yonge Street, Suite 8309 Richmond Hill, Ontario Canada L4C 9T3
Tel: +1-905-237-2004

Renesas Electronics Europe Limited
Dukes Meadow, Millboard Road, Bourne End, Buckinghamshire, SL8 5FH, U.K
Tel: +44-1628-651-700, Fax: +44-1628-651-804

Renesas Electronics Europe GmbH
Arcadiastrasse 10, 40472 Düsseldorf, Germany
Tel: +49-211-6503-0, Fax: +49-211-6503-1327

Renesas Electronics (China) Co., Ltd.
Room 1709 Quantum Plaza, No.27 ZhichunLu, Haidian District, Beijing, 100191 P. R. China
Tel: +86-10-8235-1155, Fax: +86-10-8235-7679

Renesas Electronics (Shanghai) Co., Ltd.
Unit 301, Tower A, Central Towers, 555 Langao Road, Putuo District, Shanghai, 200333 P. R. China
Tel: +86-21-2226-0888, Fax: +86-21-2226-0999

Renesas Electronics Hong Kong Limited
Unit 1601-1611, 16/F., Tower 2, Grand Century Place, 193 Prince Edward Road West, Mongkok, Kowloon, Hong Kong
Tel: +852-2265-6688, Fax: +852-2886-9022

Renesas Electronics Taiwan Co., Ltd.
13F, No. 363, Fu Shing North Road, Taipei 10543, Taiwan
Tel: +886-2-8175-9600, Fax: +886-2-8175-9670

Renesas Electronics Singapore Pte. Ltd.
80 Bendemeer Road, Unit #06-02 Hyflux Innovation Centre, Singapore 339949
Tel: +65-6213-0200, Fax: +65-6213-0300

Renesas Electronics Malaysia Sdn.Bhd.
Unit 1207, Block B, Menara Amcorp, Amcorp Trade Centre, No. 18, Jln Persiaran Barat, 46050 Petaling Jaya, Selangor Darul Ehsan, Malaysia
Tel: +60-3-7955-9390, Fax: +60-3-7955-9510

Renesas Electronics India Pvt. Ltd.
No.777C, 100 Feet Road, HAL 2nd Stage, Indiranagar, Bangalore 560 038, India
Tel: +91-80-67208700, Fax: +91-80-67208777

Renesas Electronics Korea Co., Ltd.
17F, KAMCO Yangjae Tower, 262, Gangnam-daero, Gangnam-gu, Seoul, 06265 Korea
Tel: +82-2-558-3737, Fax: +82-2-558-5338