

ISL62386LOEVAL1Z and ISL62386HIEVAL1Z

Quad-Output Evaluation Board

AN1456
Rev 0.00
Aug 25, 2009

The ISL62386 evaluation boards demonstrates the performance of the ISL62386 quad-output voltage controller. The ISL62386 includes two pulse-width modulated (PWM) controllers featuring Intersil's patented R³ technology and two linear regulators, LDO5 and LDO3. The PWM controllers are adjustable from 0.6V to 5.5V, and the LDOs generate fixed 5V and 3.3V outputs respectively.

The evaluation board includes independent Enable switches, one LED Power-Good indicator and numerous test points. Included with each switching channel is an on-board dynamic load generator for evaluating the transient-load response. There are two variations of the evaluation boards to provide flexible evaluation options. Table 1 shows a brief description of the evaluation boards.

TABLE 1. EVALUATION BOARD DESCRIPTION

EVALUATION BOARD	CHANNEL-1	CHANNEL-2	OCP
ISL62386LOEVAL1Z	3.3V/8A	5V/8A	~10A
ISL62386HIEVAL1Z	1.05V/15A	1.5V/15A	~20A

What's Needed

The following materials will be needed to perform testing:

- Adjustable +25V, 30A Power Supply
- +12V, 100mA Power Supply
- Precision digital multi-meter
- 4 Electronic Loads
- 4-Channel Oscilloscope

Enable Control

The evaluation board provides flexible control logic to enable or disable the outputs, and to program the two PWM channels' start-up sequence. Table 2 is the enable controller truth table. For start-up timing sequence, please refer to the datasheet waveforms.

TABLE 2. ENABLE TRUTH TABLE

EN1	EN2	START-UP SEQUENCE
Low	Low	Both Channel outputs OFF simultaneously
Low	Float	Both Channel outputs OFF simultaneously
Float	Low	Both Channel outputs OFF simultaneously
Float	Float	Both Channel outputs OFF simultaneously
Low	High	Channel-1 OFF, Channel-2 ON
High	Low	Channel-1 ON, Channel-2 OFF
High	High	Both Channel outputs ON simultaneously
Float	High	Channel-1 enabled after Channel-2 is in regulation

TABLE 2. ENABLE TRUTH TABLE (Continued)

EN1	EN2	START-UP SEQUENCE
High	Float	Channel-2 enabled after Channel-1 is in regulation

Resistor Current Sense Configuration

The evaluation board is pre-configured with inductor DCR current sense. For more precise overcurrent protection, it also provides the option of resistor current sense. Figure 1 shows the configuration for resistor current sense.

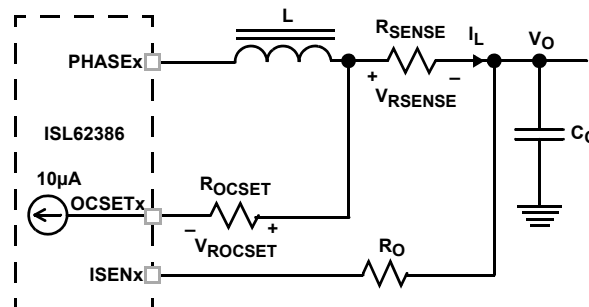

FIGURE 1. RESISTOR CURRENT SENSE CIRCUIT

For Channel-1, the ISL62386 monitors the OCSET1 pin and the ISEN1 pin voltages. Once the OCSET1 pin voltage is higher than the ISEN1 pin voltage for more than 10µs, the ISL62386 declares an overcurrent fault. For a chosen overcurrent set point I_{OC} and current sense resistor R_{SENSE}, the value of R_{OCSET} is determined by Equation 1

$$R_{OCSET} = \frac{I_{OC} \cdot R_{SENSE}}{10\mu A} \quad (EQ. 1)$$

Where:

- R_{OCSET} (Ω) is the resistor used to program the overcurrent setpoint
- I_{OC} is the output current threshold that will activate the OCP circuit
- R_{SENSE} is current sense resistor (R₃ for Channel-1 and R₂₅ for Channel-2)

Take Channel-1 as an example, once the value of R_{OCSET} is calculated, follow the following procedure to configure the resistor current sense circuit:

- Step 1: Open the "DCR SENSE" solder bridge and connect the "RESISTOR SENSE" solder bridge on the PCB bottom layer;
- Step 2: Remove R₇ (R₂₂ for Channel-2);
- Step 3: Replace R₃ (R₂₅ for Channel-2) with R_{SENSE};
- Step 4: Replace C₆ (C₂₅ for Channel-2) with R_{OCSET};
- Step 5: Replace R₁₉ (R₁₈ for Channel-2) with R_{OCSET}.

Dynamic Load Generator

The evaluation board provides each PWM channel an on-board dynamic load generator for evaluating the transient-load response, which are controlled by SW1 and SW2 respectively. The dynamic load generator applies a

300µs pulse load across V_{OUT} and GND. The transient load slew-rate can be trimmed by adjusting the resistors R_{34} , R_{40} for the rising edge, and R_{38} , R_{39} for the falling edge. +12V power supply is needed to power the dynamic load generator.

Connections and Test Points

The following table describes the function and operation of the evaluation boards.

NUMBER	NAME	FUNCTION/OPERATION
INTERFACES AND CONNECTIONS		
TP3	VBAT	V_{IN} positive power input
TP4	GND	V_{IN} return power input
TP1	VOUT1	Channel-1 positive power output
TP2	GND	Channel-1 return power output
TP11	VOUT2	Channel-2 positive power output
TP12	GND	Channel-2 return power output
TP20	+12V	+12V positive power input, used for the power supply of the on-board dynamic-load generator
TP19	GND	+12V return power input
TEST POINTS		
J1	PHASE2	Scope-probe socket for measuring Channel-2 phase node
J3	PHASE1	Scope-probe socket for measuring Channel-1 phase node
J2	VOUT1	Scope-probe socket for measuring Channel-1 output
J5	VOUT2	Scope-probe socket for measuring Channel-2 output
J4	FLOAT_FCCM	Remove the jumper will float the FCCM pin
J6	FLOAT_EN1	Remove the jumper will float the EN1 pin
J7	FLOAT_EN2	Remove the jumper will float the EN2 pin
TP17	EN1	Test point of EN1 pin
TP8	EN2	Test point of EN2 pin
TP9	LDO3EN	Test point of LDO3EN pin
TP10	FCCM	Test point of FCCM pin
POWER-GOOD INDICATOR		
TP13	PGOOD	Test point of PGOOD pin
D2		LED Power-Good indicator. Green when both Channel-1 and Channel-2 are in regulation.
LINEAR REGULATORS		
TP14	LDO5	LDO5 linear regulator positive power output
TP15	GND	LDO5 linear regulator return power output
TP6	LDO3	LDO3 linear regulator positive power output
TP7	GND	LDO3 linear regulator return power output
SWITCHES		
SW1		ON/OFF control of Channel-2 dynamic-load generator. Toggle to ON will enable the dynamic load, toggle to OFF will disable the transient load
SW2		ON/OFF control of Channel-1 dynamic-load generator. Toggle to ON will enable the dynamic load, toggle OFF will disable the transient load
U2		High: High level for EN1, EN2, LDO3EN and FCCM, respectively Low: Low level for EN1, EN2, LDO3EN and FCCM, respectively

Test Set-up

Figure 2 shows a typical test configuration.

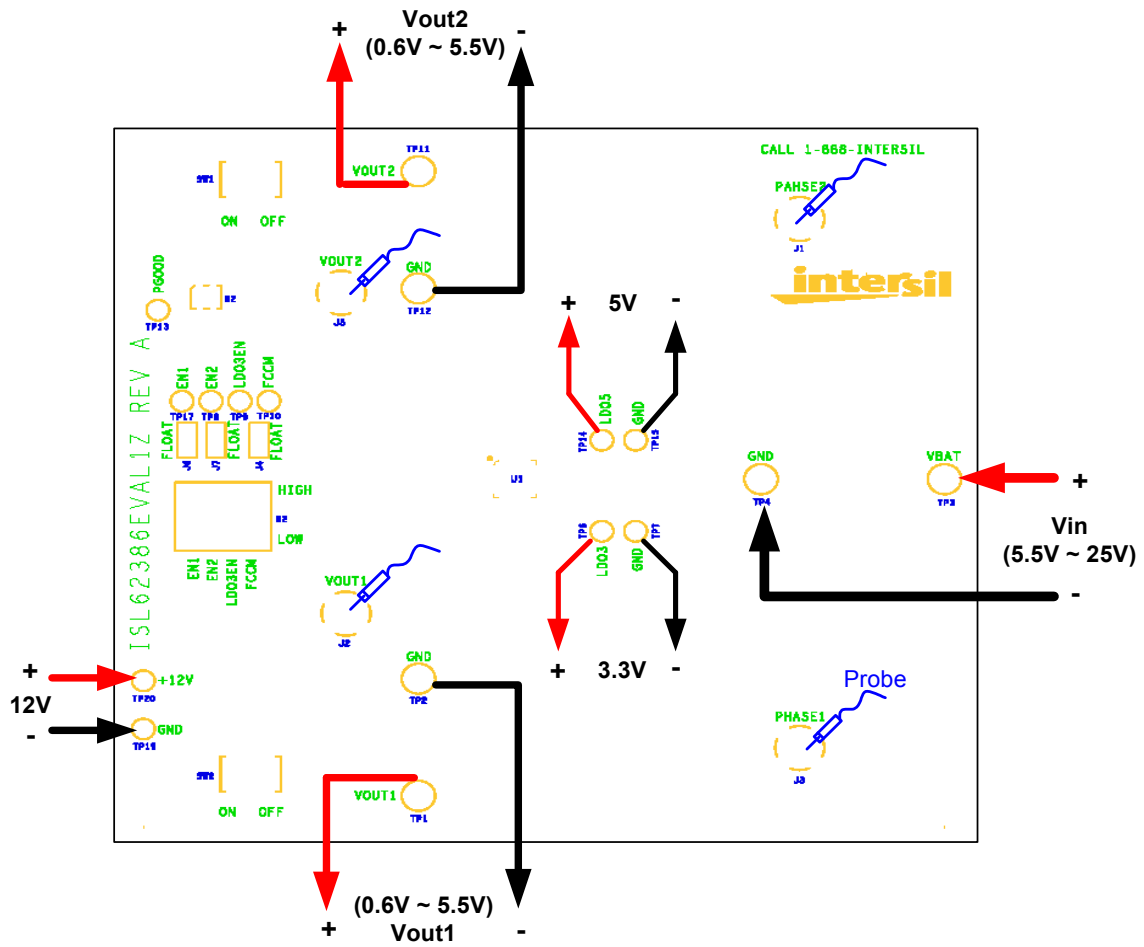

FIGURE 2. TYPICAL TEST CONFIGURATION

ISL62386LOEVAL1Z Evaluation Board Bill of Materials

NO.	REFERENCE DESIGNATOR	QTY	VALUE	VOLTAGE/ POWER	TOL. (%)	MANUFACTURER	DESCRIPTION
1	C6, C25	2	0.022 μ F	25V	10	GENERIC	SM_CAP_0603, 0.022 μ F, 25V, 10%, X7R, ROHS
2	C8, C9	2	0.01 μ F	16V	10	GENERIC	SM_CAP_0603, 0.01 μ F, 16V, 10%, X7R, ROHS
3	C17, C19	2	0.22 μ F	16V	10	GENERIC	SM_CAP_0603, 0.22 μ F, 16V, 10%, X7R, ROHS
4	C13, C15, C22, C23	4	10 μ F	25V	10	GENERIC	SM_CAP_1206, 10 μ F, 25V, 10%, X7R, ROHS
5	C12, C14	2	1200pF	16V	10	GENERIC	SM_CAP_0603, 1200PF, 16V, 10%, X7R, ROHS
6	C10, C16, C18	3	1 μ F	16V	10	GENERIC	SM_CAP_0603, 1 μ F, 16V, 10%, X7R, ROHS
7	C30	1	1 μ F	25V	10	GENERIC	SM_CAP_0805, 1 μ F, 25V, 10%, X7R, ROHS
8	C11, C24	2	1 μ F	25V	10	GENERIC	SM_CAP_1206, 1 μ F, 25V, 10%, X7R, ROHS
9	C1, C2, C20, C21, C28, C29	6	4.7 μ F	10V	10	GENERIC	SM_CAP_0805, 4.7 μ F, 10V, 10%, X7R, ROHS
10	C31, C32	2	10 μ F	16V	10	GENERIC	SM_CAP_0805, 10 μ F, 16V, 10%, X5R, ROHS
11	C3	1	56 μ F	25V	20	SANYO-OSCON	RADIAL_POLCAP_RADIAL, 25SP56M, 56 μ F, 25V, 20%, CASE-CC
12	C4, C26	2	330 μ F	6.3V	10	SANYO-POSCAP	SM_POLCAP_SMD, 6TPF330M9L, 330UF, 6.3V, 10%, CAP_7343
13	R12, R15	2	750	1/10W	1	GENERIC	SM_RES_0603, 750, 1/10W, 1%, TF, ROHS
14	R11	1	10k	1/10W	1	GENERIC	SM_RES_0603, 10k, 1/10W, 1%, TF, ROHS
15	R14	1	9.09k	1/10W	1	GENERIC	SM_RES_0603, 9.09k, 1/10W, 1%, TF, ROHS
16	R13	1	68.1k	1/10W	1	GENERIC	SM_RES_0603, 68.1k, 1/10W, 1%, TF, ROHS
17	R7, R18, R19, R22	4	15.8k	1/10W	1	GENERIC	SM_RES_0603, 15.8k, 1/10W, 1%, TF, ROHS
18	R8	1	19.6k	1/10W	1	GENERIC	SM_RES_0603, 19.6k, 1/10W, 1%, TF, ROHS
19	R9	1	24.3k	1/10W	1	GENERIC	SM_RES_0603, 24.3k, 1/10W, 1%, TF, ROHS
20	R16	1	45.3k	1/10W	1	GENERIC	SM_RES_0603, 45.3k, 1/10W, 1%, TF, ROHS
21	R20, R33, R39	3	1k	1/10W	1	GENERIC	SM_RES_0603, 1k, 1/10W, 1%, TF, ROHS
22	R38	1	1.58k	1/10W	1	GENERIC	SM_RES_0603, 1.58k, 1/10W, 1%, TF, ROHS
23	R17, R32	2	48.7k	1/10W	1	GENERIC	SM_RES_0603, 48.7k, 1/10W, 1%, TF, ROHS
24	R1, R2	2	0	1/10W	1	GENERIC	SM_RES_0603, 0, 1/10W, 1%, TF, ROHS
25	R34, R40	2	200	1/10W	1	GENERIC	SM_RES_0603, 200, 1/10W, 1%, TF, ROHS
26	R27	1	499	1/10W	1	GENERIC	SM_RES_0603, 499, 1/10W, 1%, TF, ROHS
27	R21, R23, R24, R28, R31	5	100k	1/10W	1	GENERIC	SM_RES_0603, 100k, 1/10W, 1%, TF, ROHS
28	R35	1	0.7	1W	1	GENERIC	SM_RES_2512, 0.7, 1W, 1%, TF, ROHS
29	R37	1	0.5	1W	1	GENERIC	SM_RES_2512, 0.5, 1W, 1%, TF, ROHS
30	D2	1	SSL_LXA3025IGC			LUMEX	SSL_LXA3025IGC_SMD-SSL-LXA3025IGC, LED_3x2_5MM
31	D3, D4	2	BAT54S			DIODES	SM_SCHOTTKY_BAT54S-BAT54S, SOT23
32	Q2, Q4	2	IRF7821PBF			IR	30V 13.6A N-Channel HEXFET Power MOSFET (Pb-free)
33	Q3, Q5	2	IRF7832PBF			IR	30V 20A N-Channel HEXFET Power MOSFET (Pb-free)
34	Q6, Q10, Q12	3	2N7002-7-F			FAIRCHILD	2N7002_SOT23-2N7002-7-F, SOT23

ISL62386LOEVAL1Z Evaluation Board Bill of Materials (Continued)

NO.	REFERENCE DESIGNATOR	QTY	VALUE	VOLTAGE/ POWER	TOL. (%)	MANUFACTURER	DESCRIPTION
35	Q11, Q13	2	SUD50N03-07			VISHAY	SUD50N03_07_TO252-SUD50N03-07, TO-252AA
36	SW1, SW2	2	GT11MSCBE-T			C&K	GT11MSCKE_SMT-GT11MSCBE-T, GT13MSCKE
37	TP6, TP7, TP8, TP9, TP10, TP13, TP14, TP15, TP17, TP18, TP19, TP20	12	5002			KEYSTONE	TEST_POINT_THOLE-5002,MTP500X
38	TP1, TP2, TP3, TP4, TP11, TP12	6	1514-2			KEYSTONE	TEST_POINT_THOLE-1514-2,TP-150C100P
39	J1, J2, J3, J5	4	131-5031-00			TEKTRONIX	SCOPE_PROBE_5P_CONN-131-5031-00, TEK131-5031-00
40	J4, J6, J7	3	68000-236			FCI	CONN2_DIP2-68000-236, CONN2
41	U2	1	78B04S			GRAYHILL	DIP_SW4_SPST_DIP-78B04S, DIP8-SW4
42	U1	1	ISL62386HRTZ			INTERSIL	ISL62386HRTZ, 32 LD 5x5 TQFN
43	U3, U4	2	HIP2100IBZ			INTERSIL	HIP2100_SOIC-HIP2100IBZ,SOIC8_150_50
44	L1, L2	2	4.7 μ H		20%	VISHAY	VISHAY_IHLP_5050CE_SMT-20%-IHLP- 5050CE-01-4R7M, 4.7 μ H, 24A, 20%, VISHAY_IHLP-5050CE
45	R3, R25	2	Wire			GENERIC	Wire short
46	DCR SENSE	4	Wire			GENERIC	Wire short
47	Jumper Connector	3	SPC02SYAN			SULLINS	Connector Jumper for J4, J6, J7
48		1	PCB			TBD	ISL62386EVAL1Z REVA PCB
49		1	Label			TBD	LABEL, FOR SERIAL NUMBER AND BOM REV #
50	C5, C27, C33, C34, C35, C36	6	No-pop				
51	R26, R36, R41	3	No-pop				
52	Q7, Q8, Q9, Q14	4	No-pop				

ISL62386HIEVAL1Z Evaluation Board Bill of Materials

The ISL62386HIEVAL1Z evaluation board use the same PCB and schematic as the ISL62386LOEVAL1Z evaluation boards but different bill of materials (BOM). The following table shows the BOM difference of ISL62386HIEVAL1Z in comparison with ISL62386LOEVAL1Z.

NO.	REFERENCE DESIGNATOR	QTY	VALUE	VOLTAGE /POWER	TOL. (%)	MANUFACTURER	DESCRIPTION
1	Q8, Q14	2	IRF7821PBF			IR	30V 13.6A N-Channel HEXFET Power MOSFET (Pb-free)
2	Q7, Q9	2	IRF7832PBF			IR	30V 20A N-Channel HEXFET Power MOSFET (Pb-free)
3	R8	1	14k	1/10W	1	GENERIC	SM_RES_0603, 14k, 1/10W, 1%, TF, ROHS
4	R9	1	17.4k	1/10W	1	GENERIC	SM_RES_0603, 17.4k, 1/10W, 1%, TF, ROHS
5	R11	1	23.2k	1/10W	1	GENERIC	SM_RES_0603, 23.2k, 1/10W, 1%, TF, ROHS
6	R16	1	17.8k	1/10W	1	GENERIC	SM_RES_0603, 17.8k, 1/10W, 1%, TF, ROHS
7	R13	1	15k	1/10W	1	GENERIC	SM_RES_0603, 15k, 1/10W, 1%, TF, ROHS
8	R14	1	10k	1/10W	1	GENERIC	SM_RES_0603, 10k, 1/10W, 1%, TF, ROHS
9	R7, R18, R19, R22	4	16.2k	1/10W	1	GENERIC	SM_RES_0603, 16.2k, 1/10W, 1%, TF, ROHS
10	R35	1	0.2	1W	1	GENERIC	SM_RES_2512, 0.2, 1W, 1%, TF, ROHS
11	R37	1	0.1	1W	1	GENERIC	SM_RES_2512, 0.1, 1W, 1%, TF, ROHS
12	R38	1	4.02k	1/10W	1	GENERIC	SM_RES_0603, 4.02k, 1/10W, 1%, TF, ROHS
13	R12, R15	2	590	1/10W	1	GENERIC	SM_RES_0603, 590, 1/10W, 1%, TF, ROHS
14	C12, C14	2	1800pF	16V	10	GENERIC	SM_CAP_0603, 1800PF, 16V, 10%, X7R, ROHS
15	C33, C36	2	330µF	6.3V	10	SANYO-POSCAP	SM_POLCAP_SMD, 6TPF330M9L, 330µF, 6.3V, 10%, CAP_7343
16	L1, L2	2	2.2µH		20	VISHAY	VISHAY_IHLP_5050CE_SMT-20%-IHLP-5050CE-01-2R2M,2.2µH, 29A, 20%, VISHAY_IHLP-5050CE

ISL62386xxEVAL1Z Evaluation Board Schematic

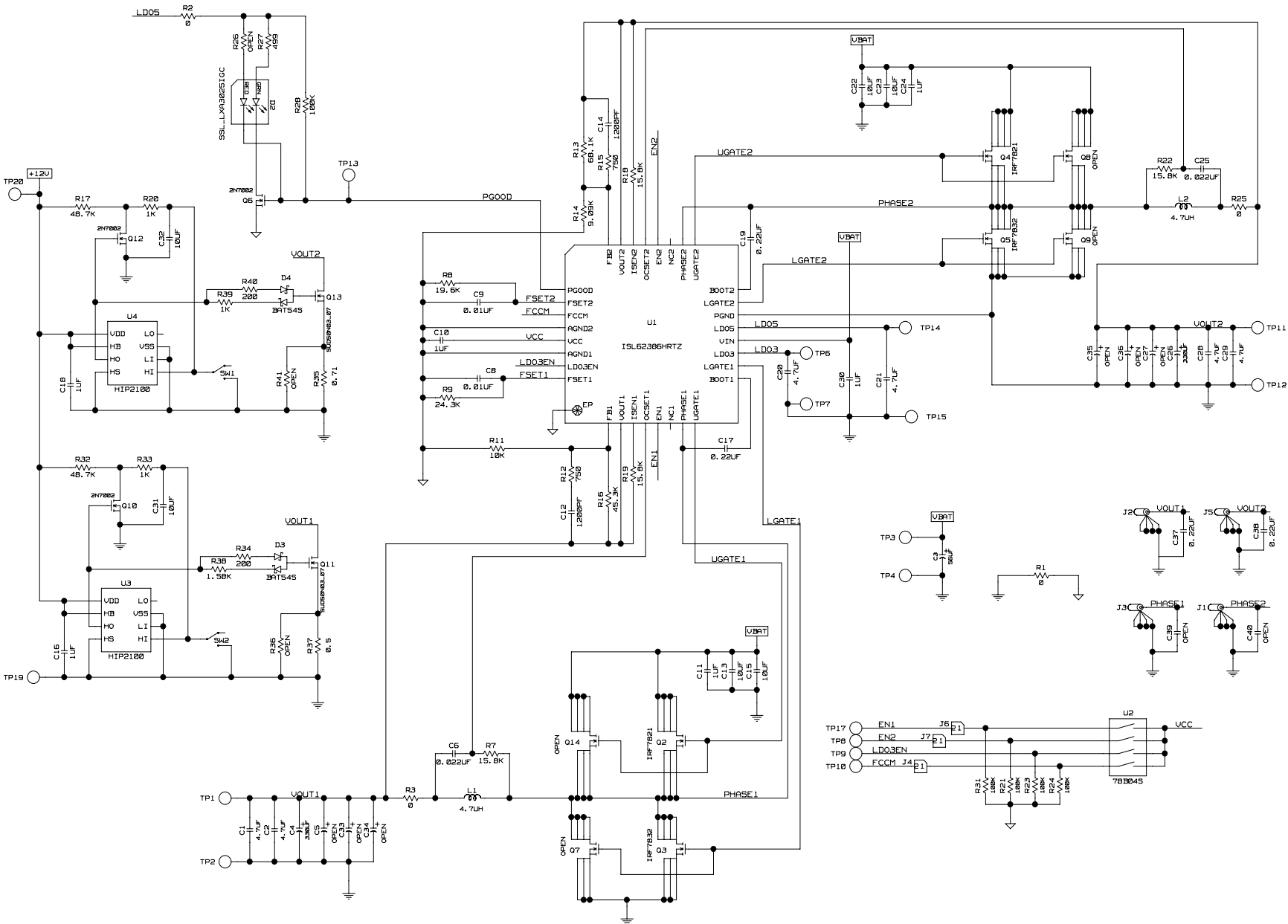

ISL62386xxEVAL1Z Evaluation Board Layout

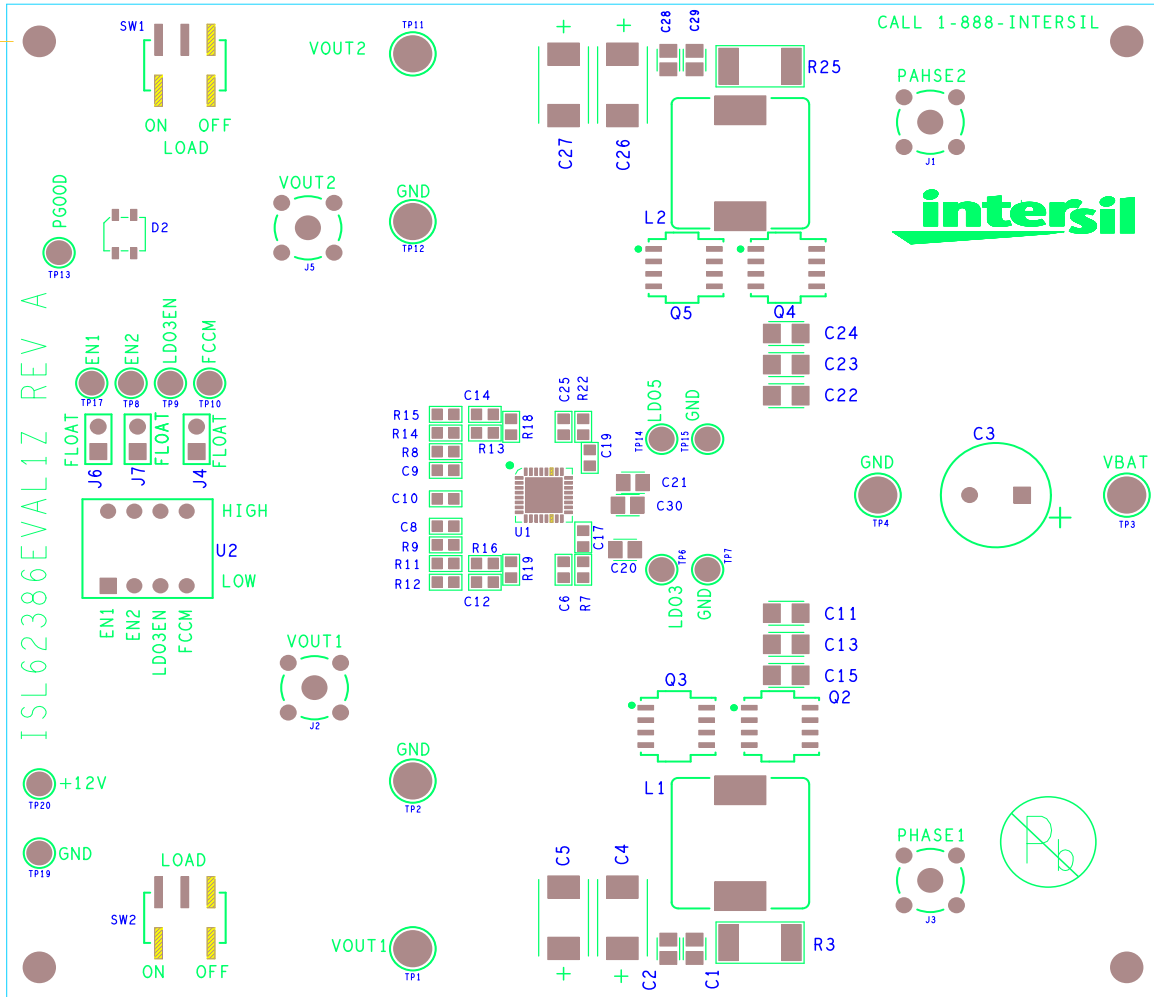

FIGURE 3. TOP SILKSCREEN

ISL62386xxEVAL1Z Evaluation Board Layout (Continued)

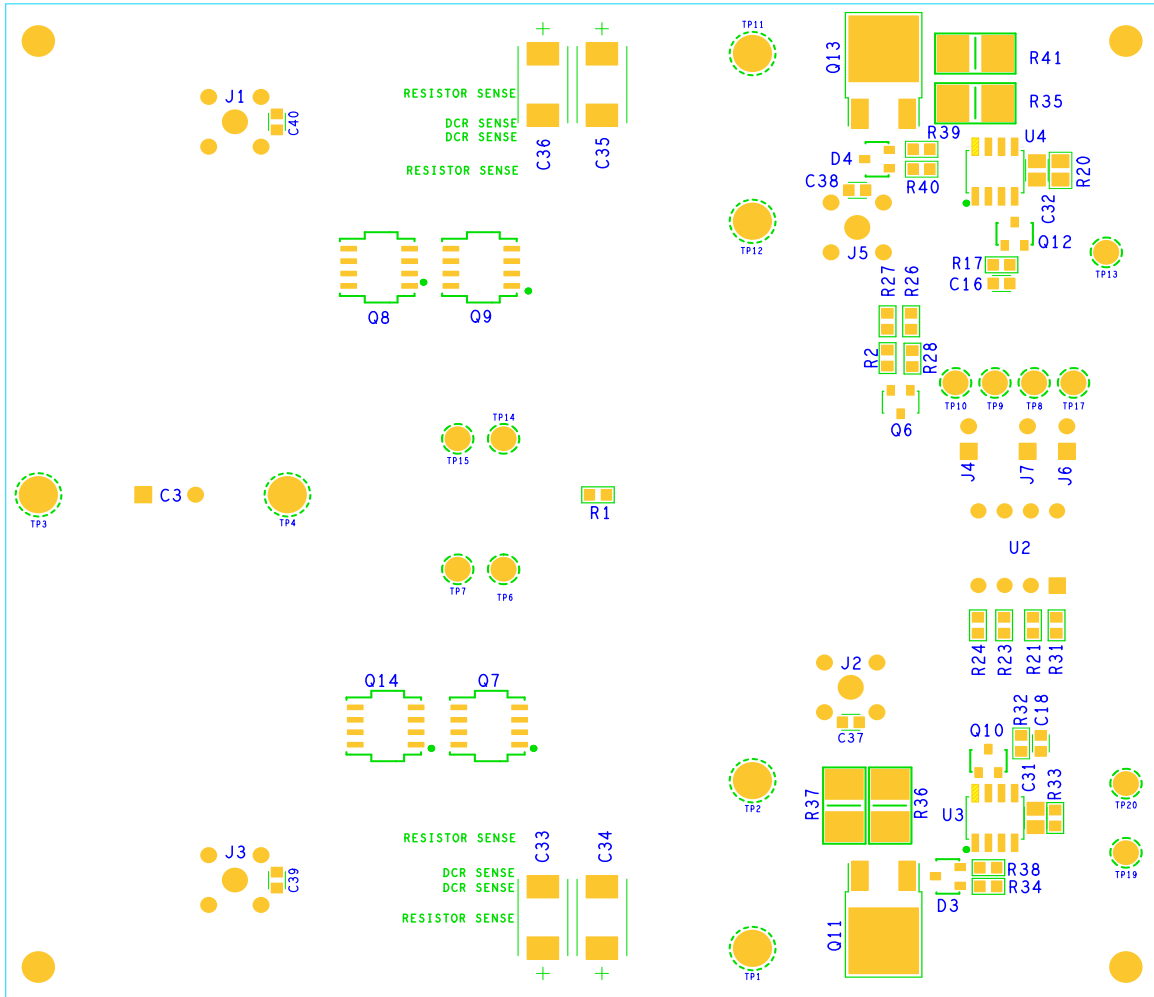

FIGURE 4. BOTTOM SILKSCREEN

ISL62386xxEVAL1Z Evaluation Board Layout (Continued)

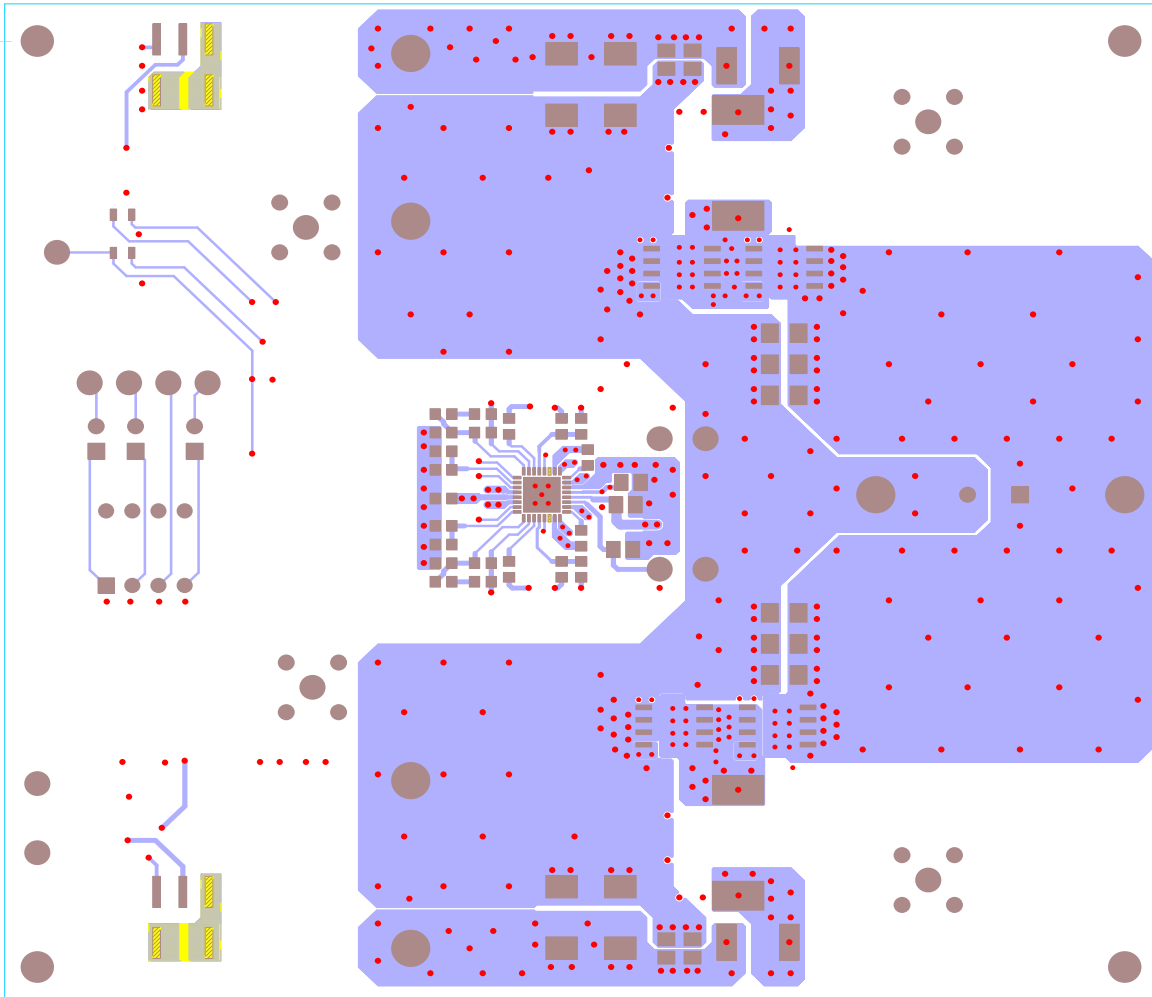

FIGURE 5. LAYER 1

ISL62386xxEVAL1Z Evaluation Board Layout (Continued)

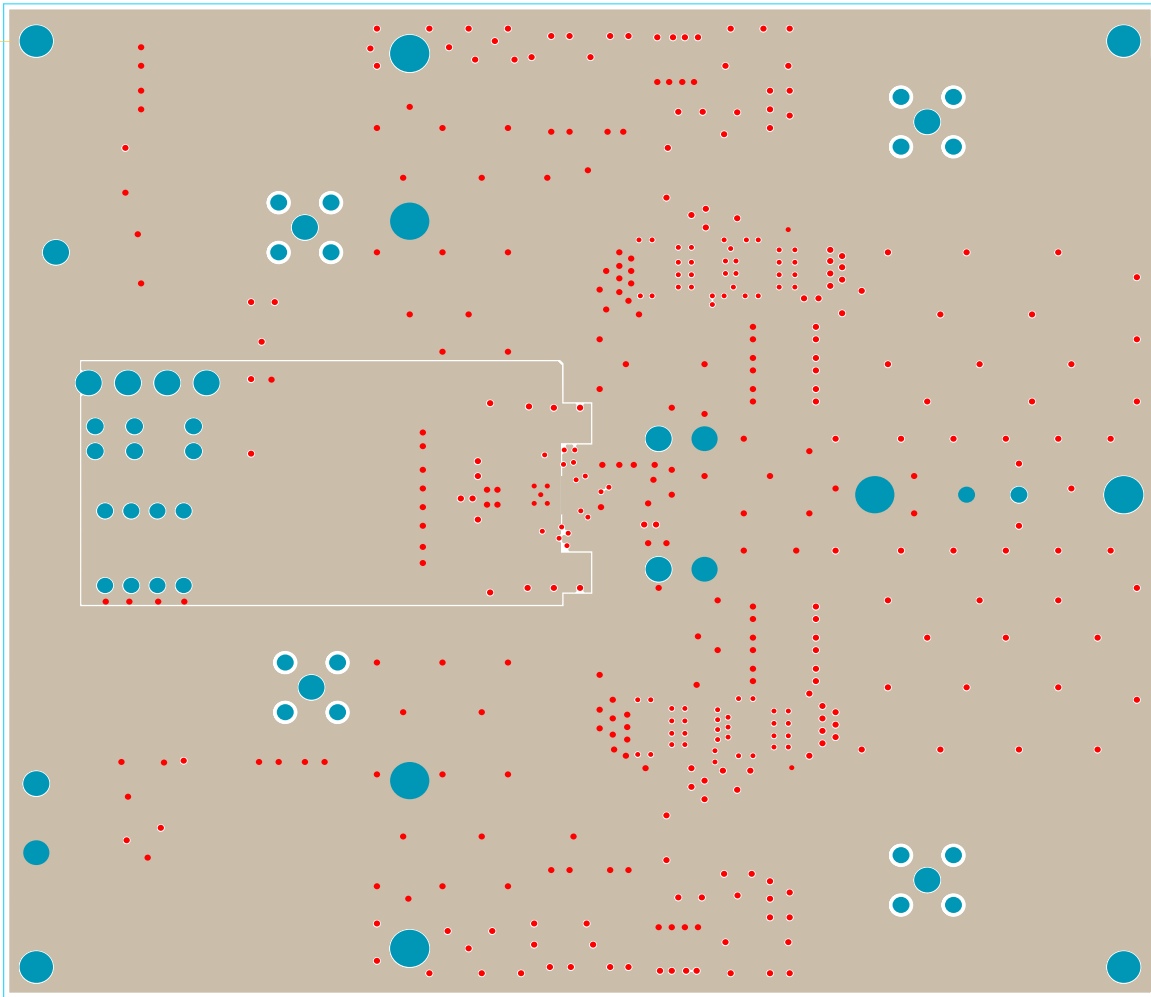

FIGURE 6. LAYER 2

ISL62386xxEVAL1Z Evaluation Board Layout (Continued)

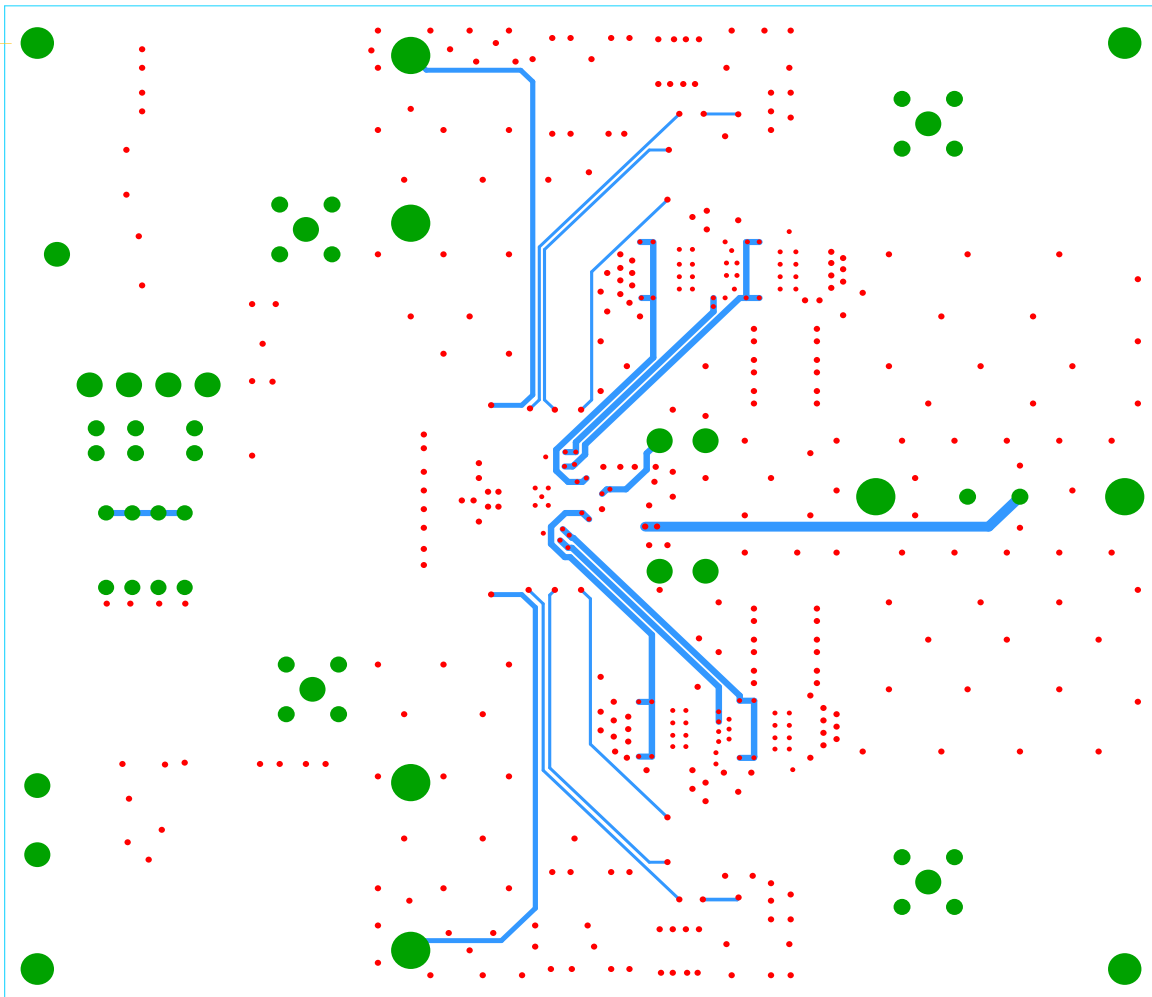

FIGURE 7. LAYER 3

ISL62386xxEVAL1Z Evaluation Board Layout (Continued)

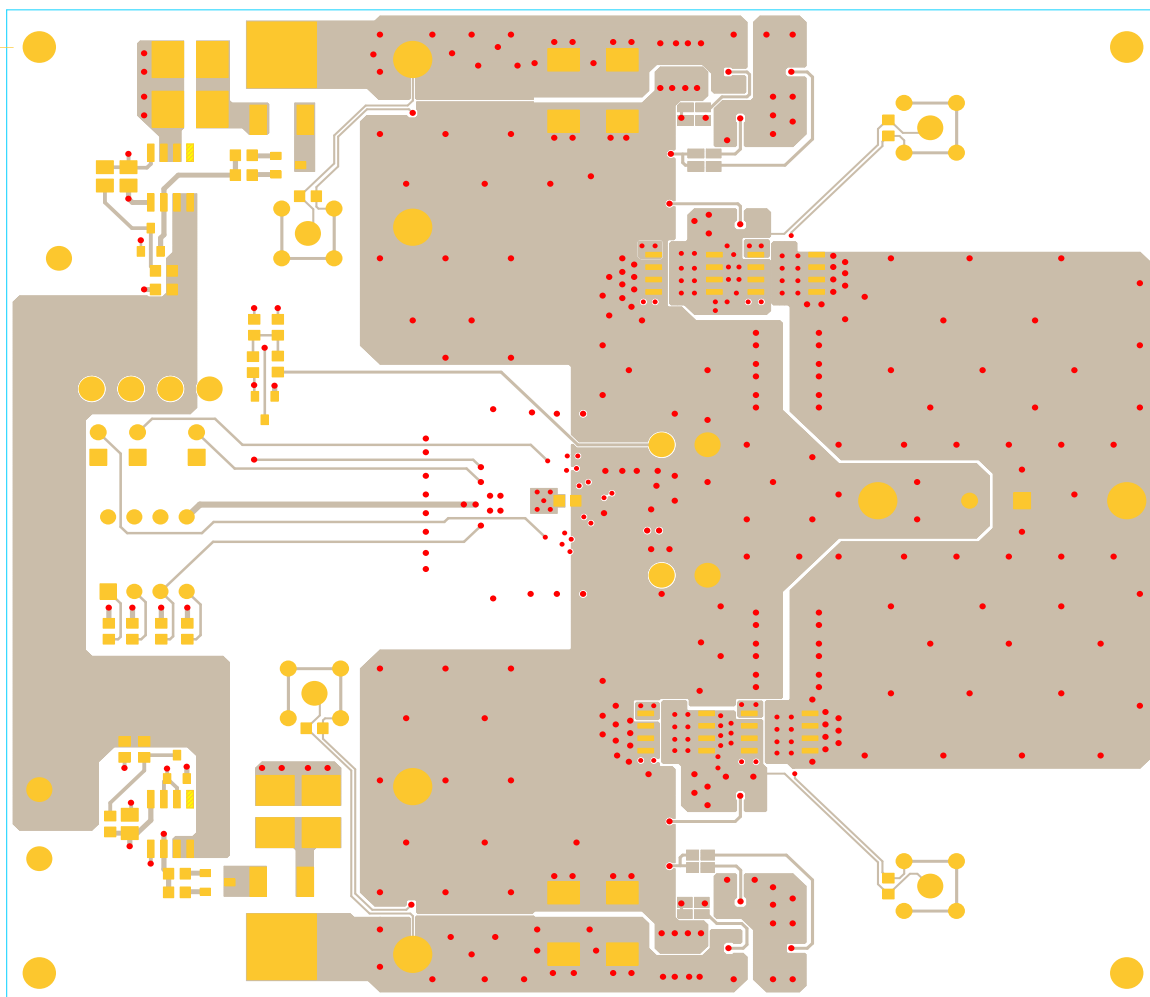

FIGURE 8. LAYER 4

Notice

1. Descriptions of circuits, software and other related information in this document are provided only to illustrate the operation of semiconductor products and application examples. You are fully responsible for the incorporation or any other use of the circuits, software, and information in the design of your product or system. Renesas Electronics disclaims any and all liability for any losses and damages incurred by you or third parties arising from the use of these circuits, software, or information.
2. Renesas Electronics hereby expressly disclaims any warranties against and liability for infringement or any other claims involving patents, copyrights, or other intellectual property rights of third parties, by or arising from the use of Renesas Electronics products or technical information described in this document, including but not limited to, the product data, drawings, charts, programs, algorithms, and application examples.
3. No license, express, implied or otherwise, is granted hereby under any patents, copyrights or other intellectual property rights of Renesas Electronics or others.
4. You shall not alter, modify, copy, or reverse engineer any Renesas Electronics product, whether in whole or in part. Renesas Electronics disclaims any and all liability for any losses or damages incurred by you or third parties arising from such alteration, modification, copying or reverse engineering.
5. Renesas Electronics products are classified according to the following two quality grades: "Standard" and "High Quality". The intended applications for each Renesas Electronics product depends on the product's quality grade, as indicated below.
"Standard": Computers; office equipment; communications equipment; test and measurement equipment; audio and visual equipment; home electronic appliances; machine tools; personal electronic equipment; industrial robots; etc.
"High Quality": Transportation equipment (automobiles, trains, ships, etc.); traffic control (traffic lights); large-scale communication equipment; key financial terminal systems; safety control equipment; etc.
Unless expressly designated as a high reliability product or a product for harsh environments in a Renesas Electronics data sheet or other Renesas Electronics document, Renesas Electronics products are not intended or authorized for use in products or systems that may pose a direct threat to human life or bodily injury (artificial life support devices or systems; surgical implantations; etc.), or may cause serious property damage (space system; undersea repeaters; nuclear power control systems; aircraft control systems; key plant systems; military equipment; etc.). Renesas Electronics disclaims any and all liability for any damages or losses incurred by you or any third parties arising from the use of any Renesas Electronics product that is inconsistent with any Renesas Electronics data sheet, user's manual or other Renesas Electronics document.
6. When using Renesas Electronics products, refer to the latest product information (data sheets, user's manuals, application notes, "General Notes for Handling and Using Semiconductor Devices" in the reliability handbook, etc.), and ensure that usage conditions are within the ranges specified by Renesas Electronics with respect to maximum ratings, operating power supply voltage range, heat dissipation characteristics, installation, etc. Renesas Electronics disclaims any and all liability for any malfunctions, failure or accident arising out of the use of Renesas Electronics products outside of such specified ranges.
7. Although Renesas Electronics endeavors to improve the quality and reliability of Renesas Electronics products, semiconductor products have specific characteristics, such as the occurrence of failure at a certain rate and malfunctions under certain use conditions. Unless designated as a high reliability product or a product for harsh environments in a Renesas Electronics data sheet or other Renesas Electronics document, Renesas Electronics products are not subject to radiation resistance design. You are responsible for implementing safety measures to guard against the possibility of bodily injury, injury or damage caused by fire, and/or danger to the public in the event of a failure or malfunction of Renesas Electronics products, such as safety design for hardware and software, including but not limited to redundancy, fire control and malfunction prevention, appropriate treatment for aging degradation or any other appropriate measures. Because the evaluation of microcomputer software alone is very difficult and impractical, you are responsible for evaluating the safety of the final products or systems manufactured by you.
8. Please contact a Renesas Electronics sales office for details as to environmental matters such as the environmental compatibility of each Renesas Electronics product. You are responsible for carefully and sufficiently investigating applicable laws and regulations that regulate the inclusion or use of controlled substances, including without limitation, the EU RoHS Directive, and using Renesas Electronics products in compliance with all these applicable laws and regulations. Renesas Electronics disclaims any and all liability for damages or losses occurring as a result of your noncompliance with applicable laws and regulations.
9. Renesas Electronics products and technologies shall not be used for or incorporated into any products or systems whose manufacture, use, or sale is prohibited under any applicable domestic or foreign laws or regulations. You shall comply with any applicable export control laws and regulations promulgated and administered by the governments of any countries asserting jurisdiction over the parties or transactions.
10. It is the responsibility of the buyer or distributor of Renesas Electronics products, or any other party who distributes, disposes of, or otherwise sells or transfers the product to a third party, to notify such third party in advance of the contents and conditions set forth in this document.
11. This document shall not be reprinted, reproduced or duplicated in any form, in whole or in part, without prior written consent of Renesas Electronics.
12. Please contact a Renesas Electronics sales office if you have any questions regarding the information contained in this document or Renesas Electronics products.
(Note 1) "Renesas Electronics" as used in this document means Renesas Electronics Corporation and also includes its directly or indirectly controlled subsidiaries.
(Note 2) "Renesas Electronics product(s)" means any product developed or manufactured by or for Renesas Electronics.

(Rev.4.0-1 November 2017)



SALES OFFICES

Renesas Electronics Corporation

<http://www.renesas.com>

Refer to "<http://www.renesas.com/>" for the latest and detailed information.

Renesas Electronics America Inc.

1001 Murphy Ranch Road, Milpitas, CA 95035, U.S.A.
Tel: +1-408-432-8888, Fax: +1-408-434-5351

Renesas Electronics Canada Limited

9251 Yonge Street, Suite 8309 Richmond Hill, Ontario Canada L4C 9T3
Tel: +1-905-237-2004

Renesas Electronics Europe Limited

Dukes Meadow, Millboard Road, Bourne End, Buckinghamshire, SL8 5FH, U.K
Tel: +44-1628-651-700, Fax: +44-1628-651-804

Renesas Electronics Europe GmbH

Arcadiastrasse 10, 40472 Düsseldorf, Germany
Tel: +49-211-6503-0, Fax: +49-211-6503-1327

Renesas Electronics (China) Co., Ltd.

Room 1709 Quantum Plaza, No.27 ZhichunLu, Haidian District, Beijing, 100191 P. R. China
Tel: +86-10-8235-1155, Fax: +86-10-8235-7679

Renesas Electronics (Shanghai) Co., Ltd.

Unit 301, Tower A, Central Towers, 555 Langao Road, Putuo District, Shanghai, 200333 P. R. China
Tel: +86-21-2226-0888, Fax: +86-21-2226-0999

Renesas Electronics Hong Kong Limited

Unit 1601-1611, 16/F., Tower 2, Grand Century Place, 193 Prince Edward Road West, Mongkok, Kowloon, Hong Kong
Tel: +852-2265-6688, Fax: +852 2886-9022

Renesas Electronics Taiwan Co., Ltd.

13F, No. 363, Fu Shing North Road, Taipei 10543, Taiwan
Tel: +886-2-8175-9600, Fax: +886 2-8175-9670

Renesas Electronics Singapore Pte. Ltd.

80 Bendemeer Road, Unit #06-02 Hyflux Innovation Centre, Singapore 339949
Tel: +65-6213-0200, Fax: +65-6213-0300

Renesas Electronics Malaysia Sdn.Bhd.

Unit 1207, Block B, Menara Amcorp, Amcorp Trade Centre, No. 18, Jln Persiaran Barat, 46050 Petaling Jaya, Selangor Darul Ehsan, Malaysia
Tel: +60-3-7955-9390, Fax: +60-3-7955-9510

Renesas Electronics India Pvt. Ltd.

No.777C, 100 Feet Road, HAL 2nd Stage, Indiranagar, Bangalore 560 038, India
Tel: +91-80-67208700, Fax: +91-80-67208777

Renesas Electronics Korea Co., Ltd.

17F, KAMCO Yangjae Tower, 262, Gangnam-daero, Gangnam-gu, Seoul, 06265 Korea
Tel: +82-2-558-3737, Fax: +82-2-558-5338