

ISL70517SEHEV1Z

Evaluation Board User Guide

UG060  
Rev 0.00  
November 6, 2015

**Description**

The ISL70517SEHEV1Z evaluation board is designed to assess the performance of the [ISL70517SEH](#) differential input, single-ended output, precision instrumentation amplifier (in-amp). With separate supply rails for the input and output stages and gain ranging from 0.1 to 10,000, this in-amp is ideal for a wide variety of applications. The gain accuracy is limited only by the matching of the gain resistors and the output is capable of driving rail-to-rail.

**Specifications**

The boards are designed to operate under the following conditions.

- Power supply range:
  - Input: 8V (±4V) to 36V (±18V)
  - Output: 3V (±1.5V) to 36V (±18V)
- Common-mode Input voltage range:  $V_{EE} + 3V$  to  $V_{CC} - 3V$
- Differential input voltage range: ±2.6V ([Note 1](#))
- Output voltage range: ±2.6V ([Note 1](#))
- Operating temperature range: -55 °C to +125 °C

NOTE:

1. The input and output voltage range may also be limited by the power supply voltages.

**Key Features**

- Separate input and output supplies allow signals riding on a high common-mode voltage to be level shifted to a low voltage device.
- Banana jack connectors for simple power supply connections.
- Multiple connectors to easily access  $V_{IN}$  and  $V_{OUT}$ .

**Reference Documents**

- [ISL70517SEH](#) Datasheet

**Ordering Information**

ORDERING NUMBER	OUTPUT	TYPE
ISL70517SEHEV1Z	Single-Ended	Evaluation Board

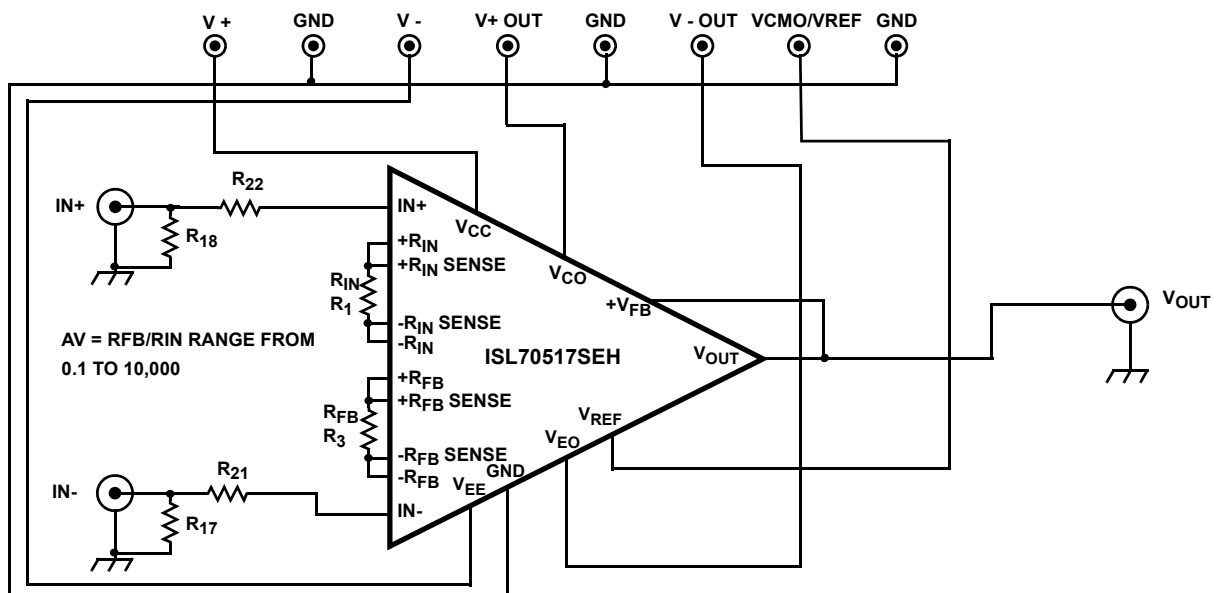

FIGURE 1. ISL70517SEH EVALUATION BOARD BLOCK DIAGRAM

## Functional Description

The schematic of the evaluation board is shown on [page 4](#). The ISL70517SEHEV1Z contains the ISL70517SEH in-amp (U1), supply decoupling capacitors (C<sub>1</sub>-C<sub>12</sub>, C<sub>15</sub>-C<sub>17</sub>), optional filter capacitors (C<sub>13</sub>, C<sub>14</sub>, C<sub>18</sub>-C<sub>21</sub>), feedback gain resistor (R<sub>1</sub>), input gain resistor (R<sub>3</sub>) and numerous filter, load and selection resistors. Component values are listed in the BOM in ["Appendix A" on page 6](#).

## Power Supplies

External power supplies are connected via the banana jack plugs (J1-J8). Each plug is labeled to identify the corresponding supply, ground, or reference voltage. The in-amp has two distinct sets of power supplies; one on the input stage and one on the output stage. The input and output supplies can be connected together externally or powered separately. Using the separate supply feature enables input signals riding on a high common-mode voltage to be level shifted to a low voltage device such as an Analog-to-Digital Converter (ADC). The operating voltage range is  $\pm 4V$  to  $\pm 36V$  for  $V_{CC}/V_{EE}$  and  $\pm 1.5V$  to  $\pm 36V$  on  $V_{CO}/V_{EO}$ . For split supply operation, the reference voltage ( $V_{REF}$ ) can be connected externally to ground.

The supply voltage on the input stage must be 3V above the maximum and 3V below the minimum input signal voltage. Note that while the output stage is rail-to-rail, the feedback returns to the input stage, which is not rail-to-rail. Therefore, the input power supply must be 3V above and below the maximum and minimum output signal as well. For more information, reference "Setting the Power Supply Voltages" of the [ISL70517SEH](#) datasheet.

## Inputs and Outputs

The input and output pins have BNC connectors (J9-J12) as well as two pin headers (J13, J16) to allow the use of differential probes. When testing the output voltage of the device under load,

it is recommended to attach the load to the BNC connector and monitor the voltage from the differential probe.

The ISL70517SEHEV1Z includes the option for an anti-aliasing filter on the output comprised of a 100 $\Omega$  resistor (R<sub>8</sub>) and 3300pF capacitor (C<sub>14</sub>). The filter is recommended when connecting the output directly to an ADC. When using the in-amp in a gain less than 1, it is possible to add a low pass filter before the input to compensate for the gain peaking at the limits of the gain bandwidth product. Resistor locations (R<sub>21</sub>, R<sub>22</sub>) and capacitors locations (C<sub>19</sub>, C<sub>20</sub>) can be used for this input filter.

## Amplifier Configuration

The ISL70517SEH evaluation board schematic is in a closed loop gain of 1 in the default configuration. To change the gain, simply replace the R<sub>3</sub> input resistor and/or the R<sub>1</sub> feedback resistor.

The in-amp gain is calculated with the following simple formula:

$$A_V = \frac{R_1}{R_3} \quad (\text{EQ. 1})$$

R<sub>1</sub> and R<sub>3</sub> also limit the maximum signal size at the input and output due to the amplifier architecture. [Table 1](#) shows the signal limits for the boards at the preset resistor values. For more information, refer to "Setting the Feedback Gain R<sub>FB</sub>" and "Setting the Input Gain R<sub>IN</sub>" of the [ISL70517SEH](#) datasheet.

[Figures 2](#) through [7](#) show several of the key performance curves generated from the ISL70517SEHEV1Z.

## Device Performance

The following plots show the performance of the in-amp that can be expected on the evaluation board.

$V_{CC} = V_{CO} = 15V$ ,  $V_{EE} = V_{EO} = -15V$ ,  $V_{REF} = 0V$  unless otherwise specified.

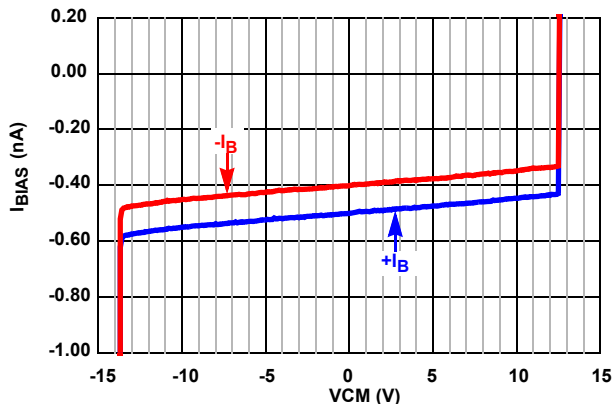

FIGURE 2.  $I_B$  vs INPUT COMMON-MODE VOLTAGE ( $\pm 15V$ )

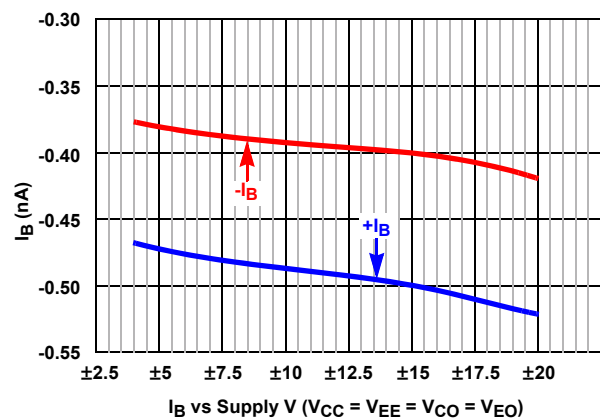

FIGURE 3.  $I_B$  vs SUPPLY VOLTAGE ( $V_{CC} - V_{EE}$ )

## Device Performance

The following plots show the performance of the in-amp that can be expected on the evaluation board.

$V_{CC} = V_{CO} = 15V$ ,  $V_{EE} = V_{EO} = -15V$ ,  $V_{REF} = 0V$  unless otherwise specified. (Continued)

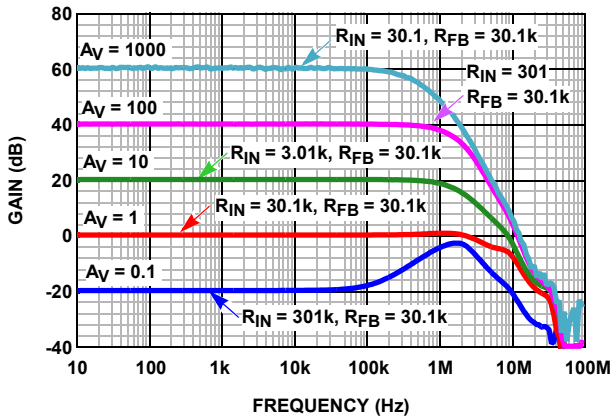

FIGURE 4. CLOSED LOOP GAIN ( $R_{FB} = 30.1k$ ) vs FREQUENCY

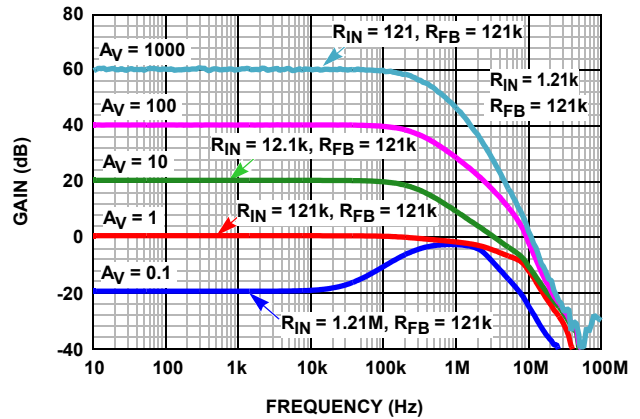

FIGURE 5. CLOSED LOOP GAIN ( $R_{FB} = 121k$ ) vs FREQUENCY

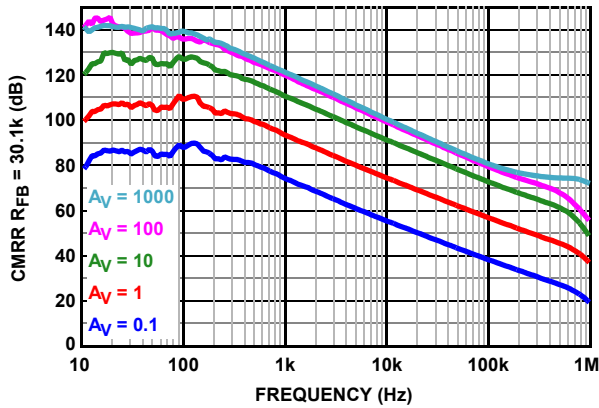

FIGURE 6. CMRR (RTI)  $R_F = 30.1k$

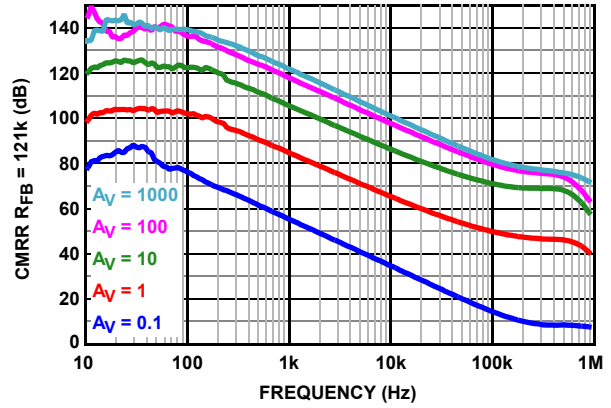

FIGURE 7. CMRR (RTI)  $R_F = 121k$

TABLE 1. RECOMMENDED INPUT AND OUTPUT VOLTAGE LIMITS FOR A GIVEN SET OF GAIN RESISTORS

$R_{IN}$ ( $\Omega$ )	$R_{FB}$ (k $\Omega$ )	GAIN	MAX RECOMMENDED $V_{IN}$ (V)	MAX RECOMMENDED $V_{OUT}$ (V)
30.1k	30.1	1	$\pm 2.0$	$\pm 2.0$
3.01k	30.1	10	$\pm 0.20$	$\pm 2.0$
301	30.1	100	$\pm 0.020$	$\pm 2.0$
301k	30.1	0.1	$\pm 20$	$\pm 2.0$

# ISL70517SEHEV1Z Schematic

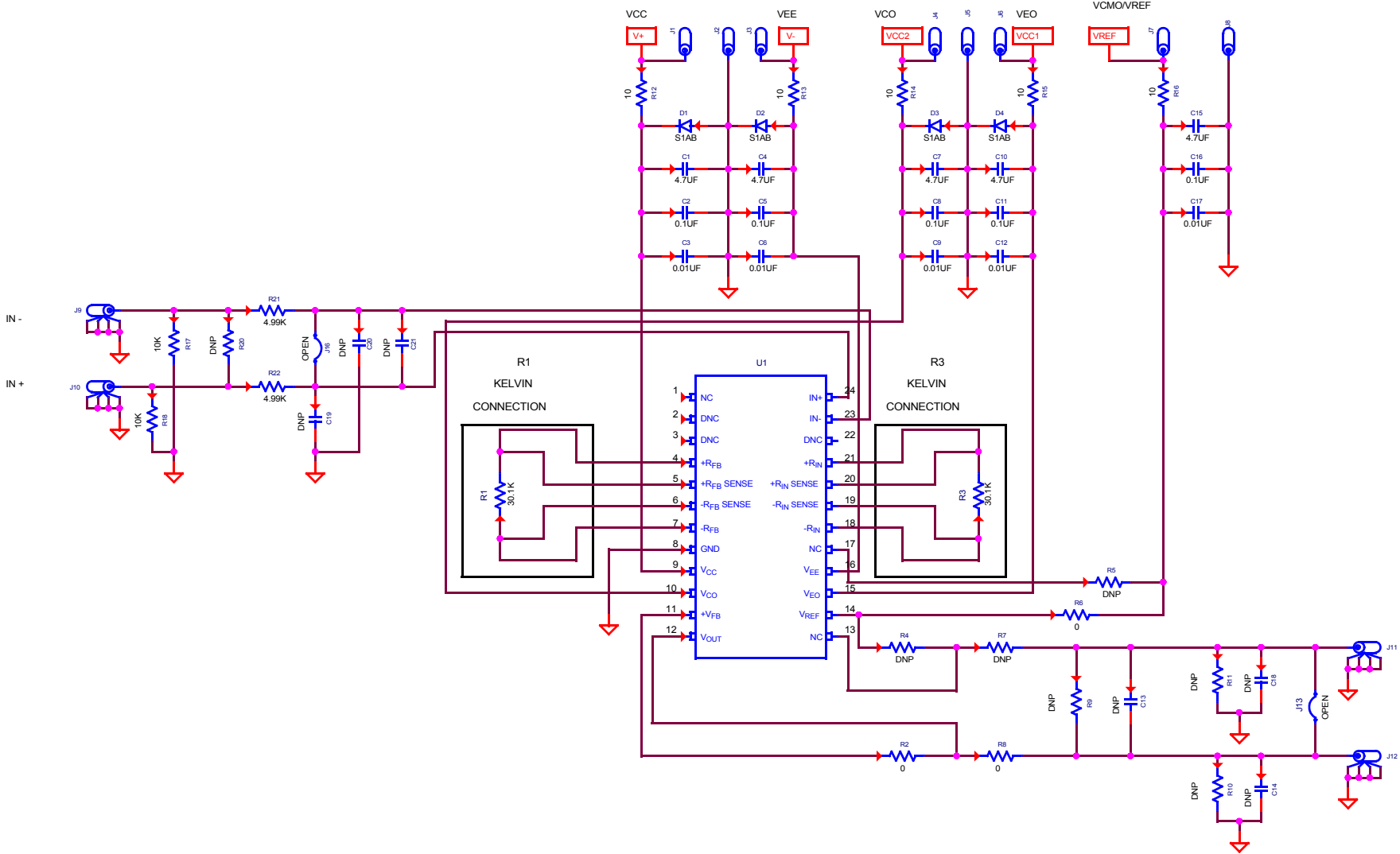

FIGURE 8. ISL70517SEHEV1Z SCHEMATIC

# In-Amp Evaluation Board Layout

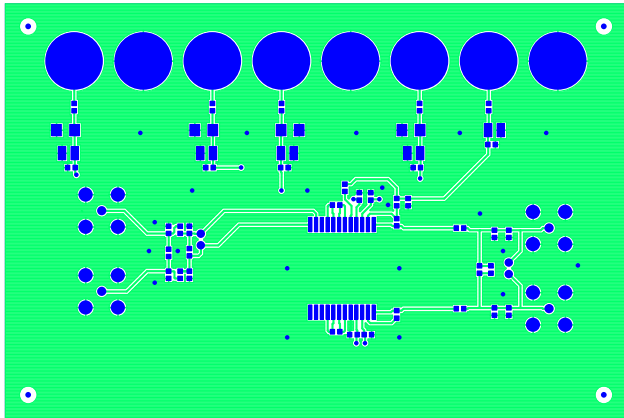

FIGURE 9. TOP LAYER

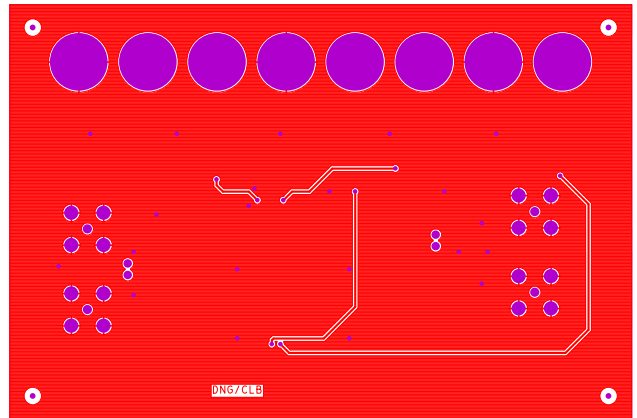

FIGURE 10. BOTTOM LAYER (VIEWED FROM BOTTOM)

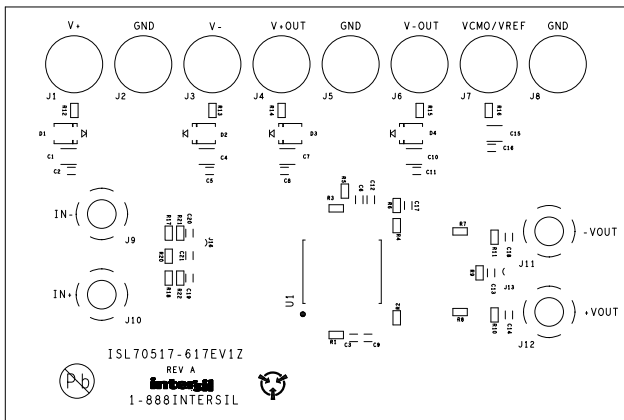

FIGURE 11. TOP SILKSCREEN



FIGURE 12. ISL70517SEHEV1Z EVALUATION BOARD

## Appendix A

TABLE 2. BILL OF MATERIALS

PART NUMBER	REFERENCE DESIGNATOR	QTY	VALUE	TOL (%)	VOLTAGE RATING (V)	POWER RATING	PKG TYPE	JEDEC TYPE	MANUFACTURER	DESCRIPTION
C1210X7R500-475KNE	C1, C4, C7, C10, C15	5	4.7 $\mu$ F	10	50		1210	CAP_1210	VENKLE CORP	CERAMIC CHIP CAP
H1045-00104-50V10	C2, C5, C8, C11, C16	5	0.1 $\mu$ F	10	50		0603	CAP_0603	GENERIC	MULTILAYER CAP
H1045-00103-50V10	C3, C6, C9, C12, C17	5	0.01 $\mu$ F	10	50		0603	CAP_0603	GENERIC	MULTILAYER CAP
H1045-OPEN	C13, C18-C21	0	DNP				0603	CAP_0603	GENERIC	DO NOT POPULATE
H1045-00332-50V10	C14	0	DNP	10	50		0603	CAP_0603	GENERIC	DO NOT POPULATE
S1AB	D1-D4	4					SMD	DIO_SMB	GENERIC	1A 50V GENERIC DIODE
108-0740-001	J1-J8	8					CONN	BAN-JACK	JOHNSON-COMPONENTS	STANDARD TYPE BANANA JACK
31-5329-52RFX	J9-J12	4					CONN	CON_BNC_31_5329_52RFX	AMPHENOL	GOLD PLATED 50 OHM PCB MOUNT RECEPTACLE
JUMPER2_100	J13, J16	2	OPEN				THOLE	JUMPER-1	GENERIC	TWO PIN JUMPER
H2505-03012-1/16WR1	R1, R3	2	30.1k	0.1		1/16W	0603	RES_0603	GENERIC	THICK FILM CHIP RESISTOR
H2511-00R00-1/16W	R2, R6, R8	3	0			1/16W	0603	RES_0603	GENERIC	THICK FILM CHIP RESISTOR
H2505-DNP-DNP-1	R4, R5, R7, R9-R11, R20	0	DNP				0603	RES_0603	GENERIC	DO NOT POPULATE
H2511-00100-1/16W1	R12-R16	5	10	1		1/16W	0603	RES_0603	GENERIC	THICK FILM CHIP RESISTOR
H2511-01002-1/16W1	R17, R18	2	10k	1		1/16W	0603	RES_0603	GENERIC	THICK FILM CHIP RESISTOR
H2511-04991-1/16W1	R21, R22	2	4.99k	1		1/16W	0603	RES_0603	GENERIC	THICK FILM CHIP RESISTOR
ISL70517SEHF/PROTO	U1	1					24PF	CDPF24_K24_A	INTERSIL	24 PIN CERAMIC FLATPACK (CDFP) PACKAGE K24.A

## Notice

1. Descriptions of circuits, software and other related information in this document are provided only to illustrate the operation of semiconductor products and application examples. You are fully responsible for the incorporation or any other use of the circuits, software, and information in the design of your product or system. Renesas Electronics disclaims any and all liability for any losses and damages incurred by you or third parties arising from the use of these circuits, software, or information.
2. Renesas Electronics hereby expressly disclaims any warranties against and liability for infringement or any other claims involving patents, copyrights, or other intellectual property rights of third parties, by or arising from the use of Renesas Electronics products or technical information described in this document, including but not limited to, the product data, drawings, charts, programs, algorithms, and application examples.
3. No license, express, implied or otherwise, is granted hereby under any patents, copyrights or other intellectual property rights of Renesas Electronics or others.
4. You shall not alter, modify, copy, or reverse engineer any Renesas Electronics product, whether in whole or in part. Renesas Electronics disclaims any and all liability for any losses or damages incurred by you or third parties arising from such alteration, modification, copying or reverse engineering.
5. Renesas Electronics products are classified according to the following two quality grades: "Standard" and "High Quality". The intended applications for each Renesas Electronics product depends on the product's quality grade, as indicated below.  
"Standard": Computers; office equipment; communications equipment; test and measurement equipment; audio and visual equipment; home electronic appliances; machine tools; personal electronic equipment; industrial robots; etc.  
"High Quality": Transportation equipment (automobiles, trains, ships, etc.); traffic control (traffic lights); large-scale communication equipment; key financial terminal systems; safety control equipment; etc.  
Unless expressly designated as a high reliability product or a product for harsh environments in a Renesas Electronics data sheet or other Renesas Electronics document, Renesas Electronics products are not intended or authorized for use in products or systems that may pose a direct threat to human life or bodily injury (artificial life support devices or systems; surgical implantations; etc.), or may cause serious property damage (space system; undersea repeaters; nuclear power control systems; aircraft control systems; key plant systems; military equipment; etc.). Renesas Electronics disclaims any and all liability for any damages or losses incurred by you or any third parties arising from the use of any Renesas Electronics product that is inconsistent with any Renesas Electronics data sheet, user's manual or other Renesas Electronics document.
6. When using Renesas Electronics products, refer to the latest product information (data sheets, user's manuals, application notes, "General Notes for Handling and Using Semiconductor Devices" in the reliability handbook, etc.), and ensure that usage conditions are within the ranges specified by Renesas Electronics with respect to maximum ratings, operating power supply voltage range, heat dissipation characteristics, installation, etc. Renesas Electronics disclaims any and all liability for any malfunctions, failure or accident arising out of the use of Renesas Electronics products outside of such specified ranges.
7. Although Renesas Electronics endeavors to improve the quality and reliability of Renesas Electronics products, semiconductor products have specific characteristics, such as the occurrence of failure at a certain rate and malfunctions under certain use conditions. Unless designated as a high reliability product or a product for harsh environments in a Renesas Electronics data sheet or other Renesas Electronics document, Renesas Electronics products are not subject to radiation resistance design. You are responsible for implementing safety measures to guard against the possibility of bodily injury, injury or damage caused by fire, and/or danger to the public in the event of a failure or malfunction of Renesas Electronics products, such as safety design for hardware and software, including but not limited to redundancy, fire control and malfunction prevention, appropriate treatment for aging degradation or any other appropriate measures. Because the evaluation of microcomputer software alone is very difficult and impractical, you are responsible for evaluating the safety of the final products or systems manufactured by you.
8. Please contact a Renesas Electronics sales office for details as to environmental matters such as the environmental compatibility of each Renesas Electronics product. You are responsible for carefully and sufficiently investigating applicable laws and regulations that regulate the inclusion or use of controlled substances, including without limitation, the EU RoHS Directive, and using Renesas Electronics products in compliance with all these applicable laws and regulations. Renesas Electronics disclaims any and all liability for damages or losses occurring as a result of your noncompliance with applicable laws and regulations.
9. Renesas Electronics products and technologies shall not be used for or incorporated into any products or systems whose manufacture, use, or sale is prohibited under any applicable domestic or foreign laws or regulations. You shall comply with any applicable export control laws and regulations promulgated and administered by the governments of any countries asserting jurisdiction over the parties or transactions.
10. It is the responsibility of the buyer or distributor of Renesas Electronics products, or any other party who distributes, disposes of, or otherwise sells or transfers the product to a third party, to notify such third party in advance of the contents and conditions set forth in this document.
11. This document shall not be reprinted, reproduced or duplicated in any form, in whole or in part, without prior written consent of Renesas Electronics.
12. Please contact a Renesas Electronics sales office if you have any questions regarding the information contained in this document or Renesas Electronics products.  
(Note 1) "Renesas Electronics" as used in this document means Renesas Electronics Corporation and also includes its directly or indirectly controlled subsidiaries.  
(Note 2) "Renesas Electronics product(s)" means any product developed or manufactured by or for Renesas Electronics.

(Rev.4.0-1 November 2017)



### SALES OFFICES

Renesas Electronics Corporation

<http://www.renesas.com>

Refer to "<http://www.renesas.com/>" for the latest and detailed information.

**Renesas Electronics America Inc.**  
1001 Murphy Ranch Road, Milpitas, CA 95035, U.S.A.  
Tel: +1-408-432-8888, Fax: +1-408-434-5351

**Renesas Electronics Canada Limited**  
9251 Yonge Street, Suite 8309 Richmond Hill, Ontario Canada L4C 9T3  
Tel: +1-905-237-2004

**Renesas Electronics Europe Limited**  
Dukes Meadow, Millboard Road, Bourne End, Buckinghamshire, SL8 5FH, U.K.  
Tel: +44-1628-651-700, Fax: +44-1628-651-804

**Renesas Electronics Europe GmbH**  
Arcadiastrasse 10, 40472 Düsseldorf, Germany  
Tel: +49-211-6503-0, Fax: +49-211-6503-1327

**Renesas Electronics (China) Co., Ltd.**  
Room 1709 Quantum Plaza, No.27 ZhichunLu, Haidian District, Beijing, 100191 P. R. China  
Tel: +86-10-8235-1155, Fax: +86-10-8235-7679

**Renesas Electronics (Shanghai) Co., Ltd.**  
Unit 301, Tower A, Central Towers, 555 Langao Road, Putuo District, Shanghai, 200333 P. R. China  
Tel: +86-21-2226-0888, Fax: +86-21-2226-0999

**Renesas Electronics Hong Kong Limited**  
Unit 1601-1611, 16/F., Tower 2, Grand Century Place, 193 Prince Edward Road West, Mongkok, Kowloon, Hong Kong  
Tel: +852-2265-6688, Fax: +852-2886-9022

**Renesas Electronics Taiwan Co., Ltd.**  
13F, No. 363, Fu Shing North Road, Taipei 10543, Taiwan  
Tel: +886-2-8175-9600, Fax: +886-2-8175-9670

**Renesas Electronics Singapore Pte. Ltd.**  
80 Bendemeer Road, Unit #06-02 Hyflux Innovation Centre, Singapore 339949  
Tel: +65-6213-0200, Fax: +65-6213-0300

**Renesas Electronics Malaysia Sdn.Bhd.**  
Unit 1207, Block B, Menara Amcorp, Amcorp Trade Centre, No. 18, Jln Persiaran Barat, 46050 Petaling Jaya, Selangor Darul Ehsan, Malaysia  
Tel: +60-3-7955-9390, Fax: +60-3-7955-9510

**Renesas Electronics India Pvt. Ltd.**  
No.777C, 100 Feet Road, HAL 2nd Stage, Indiranagar, Bangalore 560 038, India  
Tel: +91-80-67208700, Fax: +91-80-67208777

**Renesas Electronics Korea Co., Ltd.**  
17F, KAMCO Yangjae Tower, 262, Gangnam-daero, Gangnam-gu, Seoul, 06265 Korea  
Tel: +82-2-558-3737, Fax: +82-2-558-5338