

ISL73006SLHDEMO3Z

The ISL73006SLHDEMO3Z demonstration board (Figure 3) features the ISL73006SLH buck regulator. This IC is a small footprint radiation hardened POL designed for critical low-power applications.

In applications where a transformer-derived negative voltage rail is not possible, and the negative voltage rail must be generated from an existing positive voltage rail, a synchronous buck regulator like the ISL73006SLH can create the necessary negative voltage rail.

The ISL73006SLHDEMO3Z demonstration board and this accompanying manual provide a quick and easy method to evaluate the ISL73006SLH outputting -5V and using the internal compensation and slope configuration.

See the ISL73006SLH datasheet for information about the operation, function, and performance of the device.

Features

- Optimized for 5V to -5V conversion using the internal slope and compensation configuration
- -0.5A output current

Specifications

The ISL73006SLHDEMO3Z demonstration board is set up with the internal control loop compensation and slope configuration.

The board allows other conditions to be evaluated with user modification of component values but not external control loop or slope configuration.

Table 1 shows the electrical ratings of the ISL73006SLHDEMO3Z demonstration board.

Table 1. Electrical Ratings

Parameter	Rating
PVIN Supply Voltage	4V to 12V
DC Output Voltage	-5V
Operating Frequency	500kHz
Output Current	-0.5A max
Temperature	-55°C to +125°C

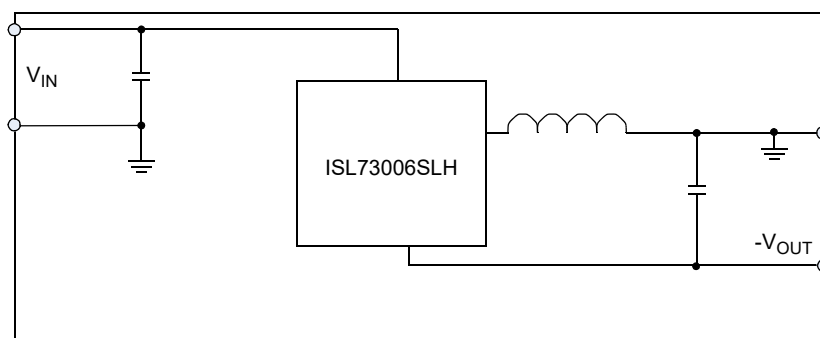

Figure 1. Block Diagram

Contents

1. Functional Description	3
1.1 Operational Characteristics	3
1.2 Setup and Configuration	3
2. Board Design	4
2.1 Basic Layout	5
2.2 Layout Guidelines	5
2.3 Schematic Diagrams	5
2.4 Bill of Materials	5
2.5 Board Layout	6
3. Typical Performance Graphs	7
4. Ordering Information	8
5. Revision History	8

1. Functional Description

The ISL73006SLHDEMO3Z demonstration board is configured by default for internal control loop and slope and optimized for 5V to 1.2V conversion with a 1A maximum output current. It contains the ISL73006SLH voltage regulator IC. [Figure 1](#) shows the ISL73006SLHDEMO3Z demonstration board block diagram. [Figure 3](#) and [Figure 4](#) show the ISL73006SLHDEMO3Z board images.

The ISL73006SLHDEMO3Z demonstration board provides access to critical pins of the IC device and convenient pads for connecting test equipment. For more information, see the schematic ([Figure 5](#)), PCB layers ([Figure 6](#) through [Figure 11](#)), and [Bill of Materials](#). [Figure 12](#) through [Figure 17](#) show the performance data using the ISL73006SLHDEMO3Z and basic lab equipment.

1.1 Operational Characteristics

The ISL73006SLHDEMO3Z only requires a single voltage supply > 3V connected to the PVIN pad to operate, outputting -5V on the VOUT pad with a 0.5A output current capability. Configured for a nominal PVIN voltage of 5V, the input operating voltage at which the IC turns on is set by the resistor divider (R_1 and R_2) on the ENABLE pin. The output inductor chosen is 22 μ H, resulting in a peak-to-peak ripple current of ~285mA. In this negative output voltage scheme, the Negative Output Current (NOC) limit is now in play. During turn-on, the LX phase current can exceed the device's NOC limit with DC loads of -500mA or more, resulting in a non-monotonic turn-on that eventually turns on and operates as expected. The performance is documented with a -400mA load.

Note: Do not exceed 5V on the ENABLE pin.

1.2 Setup and Configuration

The following equipment is recommended for testing the board:

- 5V power supply
- 100MHz oscilloscope

Complete the following steps to configure and use the board:

1. Configure the board as shown in [Figure 2](#).
2. Connect and turn on a 5V power supply to the PVIN pad.
3. Use the oscilloscope to look at VIN and VOUT waveforms and observe the behavior of the LX phase node located on pin 10 of the IC package. Proper probe grounding must be practiced when observing switching waveforms.
4. Output current loading can be externally added at the VOUT and GND pads for loaded output evaluations. A DVM(s) can monitor the input and output voltages and currents.

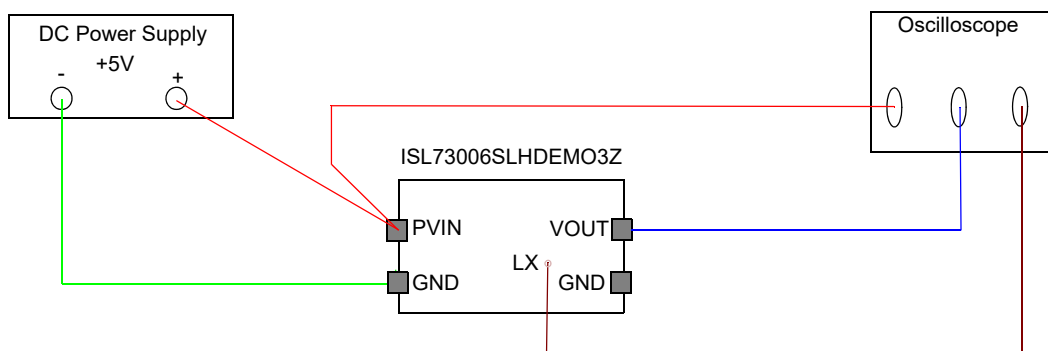

Figure 2. ISL73006SLH Basic Evaluation Test Setup Block Diagram

2. Board Design

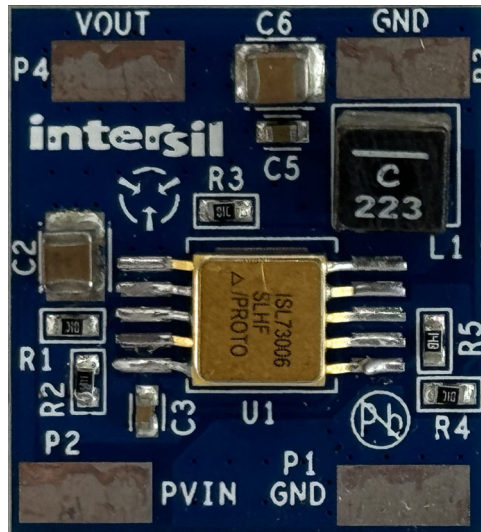

Figure 3. Demonstration Board (Top)



Figure 4. Demonstration Board (Bottom)

2.1 Basic Layout

The ISL73006SLH is located in the lower center of the board and is labeled U1. Connect the input power across the PVIN and GND pads. The output voltage appears across the VOUT and GND pads. C_{IN} is provided by C_1 and C_2 . The output LC filter is comprised of the L_{OUT} , L_1 , and bulk C_{OUT} is provided by C_6 and C_7 . The EN threshold to enable the IC when PVIN is $\sim +3V$ and is set by R_1 and R_2 . Consult the schematic in (Figure 5) for details.

2.2 Layout Guidelines

PCB design is critical to reducing parasitic inductances, with critical components being closely placed to the IC. The critical components are the low ESR ceramic input capacitors. Avoid placing traces or components under the LX shapes to avoid noise coupling from the switching node.

2.3 Schematic Diagrams

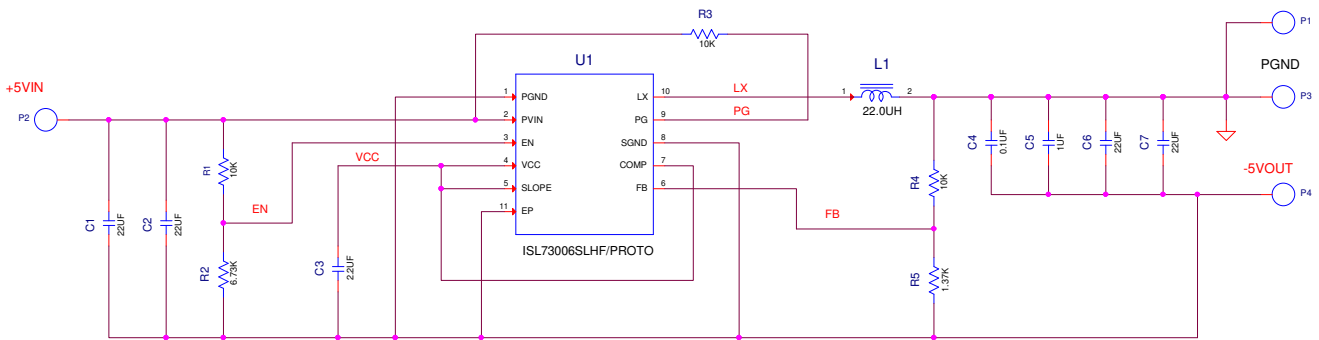

Figure 5. Schematic

2.4 Bill of Materials

Reference Designator	Description	Manufacturer	Manufacturer Part
U1	IC-RAD HARD 1A POL REGULATOR	Renesas Electronics	ISL73006SLHF/PROTO
L1	22μH;20%,3.6A;SMD Shielded Power Inductor	Coilcraft	XEL5050-223ME
C1, C2	22μF, Multilayer Cap	Various	Generic
C3	2.2μF, Multilayer Cap	Various	Generic
C4	0.1μF, Multilayer Cap	Various	Generic
C5	1μF, Multilayer Cap	Various	Generic
C6, C7	22μF, Multilayer Cap	Various	Generic
R1, R3, R4	10kΩ, Thick Film Chip Resistor	Various	Generic
R2	6.73kΩ, Thick Film Chip Resistor	Various	Generic
R5	1.37kΩ, Thick Film Chip Resistor	Various	Generic

2.5 Board Layout

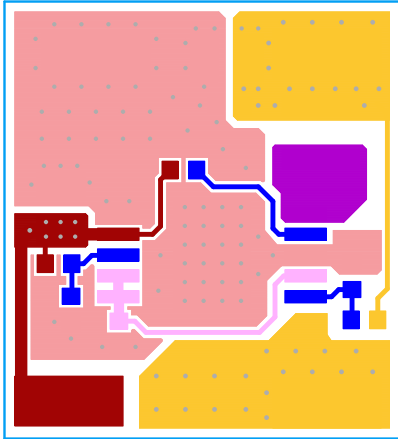

Figure 6. Top Layer

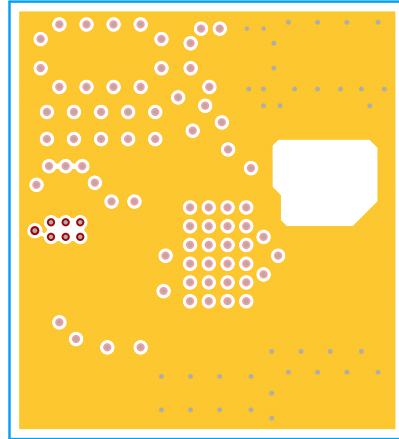

Figure 7. Layer 2

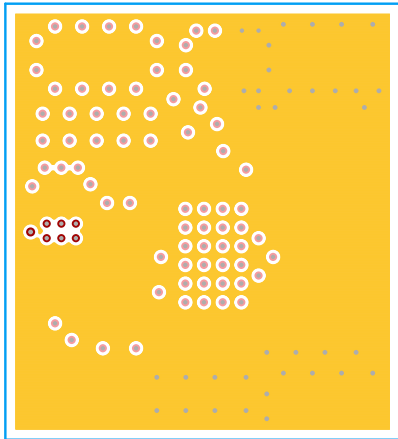

Figure 8. Layer 3

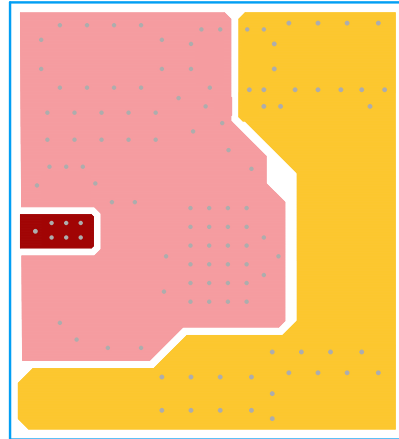

Figure 9. Bottom Layer

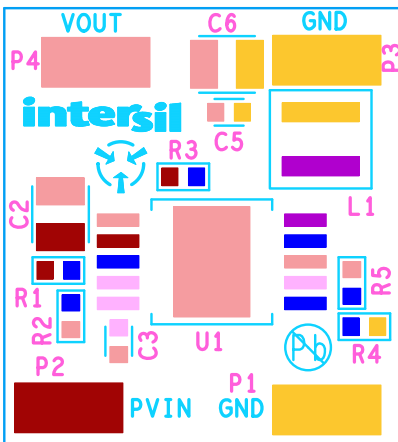

Figure 10. Top Silk Layer

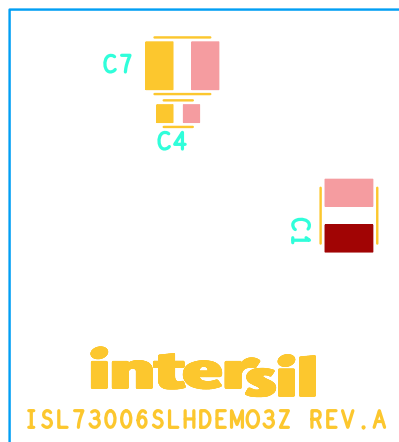

Figure 11. Bottom Silk Layer

3. Typical Performance Graphs

Unless otherwise noted, $P_{VIN} = 5V$; $V_{OUT} = -5V$, $T_A = \text{Room Ambient}$, circuit modifications necessary

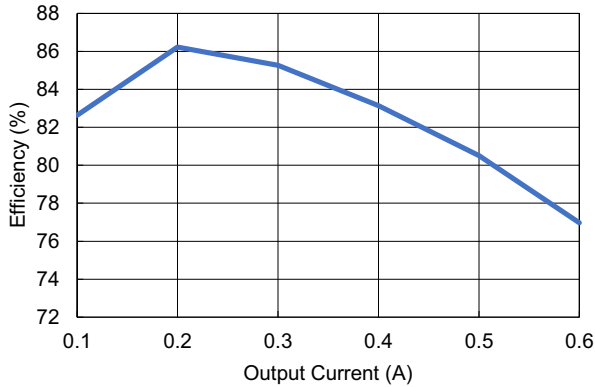

Figure 12. Efficiency vs Output Current

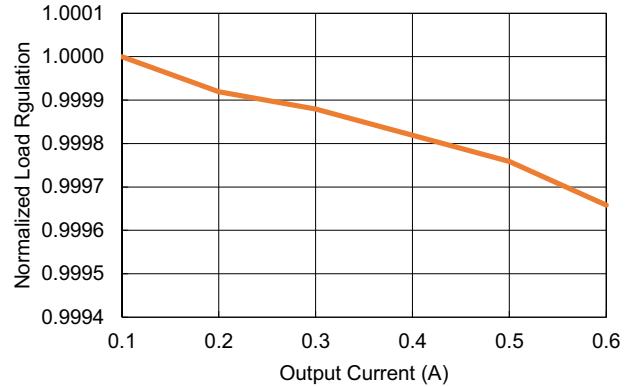

Figure 13. Load Regulation vs Output Current

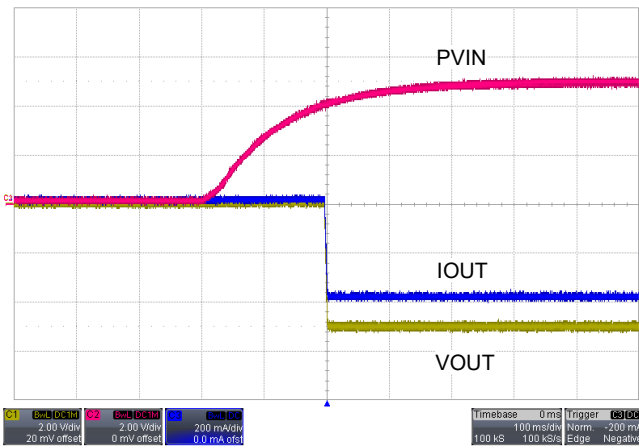

Figure 14. Turn-On by PVIN, 13Ω Load

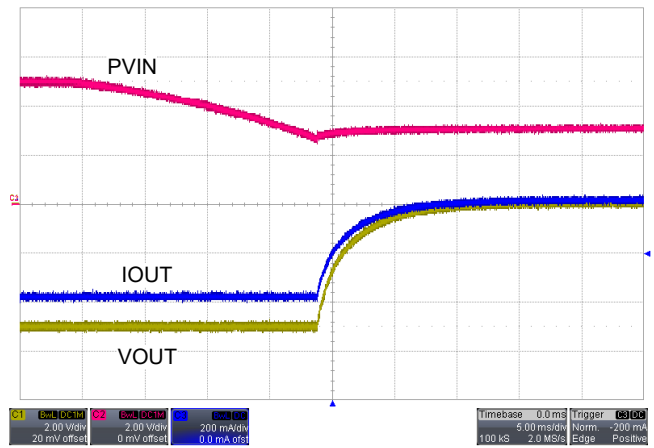

Figure 15. Turn-Off by PVIN, 13Ω Load

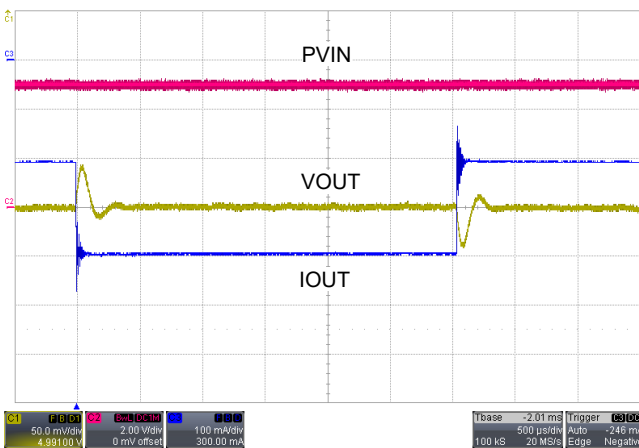

Figure 16. 0.2A Load Transient

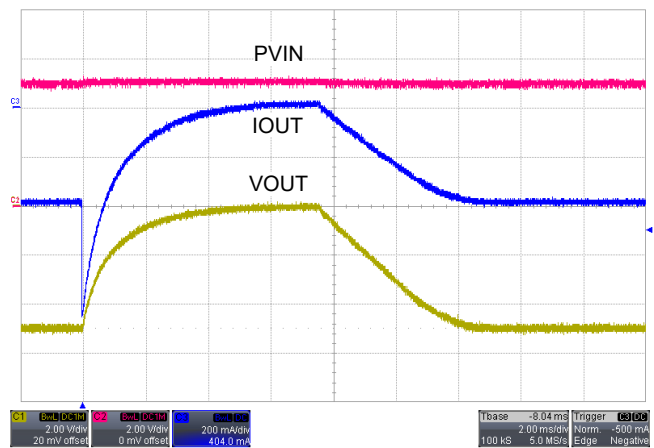

Figure 17. Overcurrent Protection and Restart

4. Ordering Information

Part Number	Description
ISL73006SLHDEMO3Z	Radiation Hardened ISL73006SLH Buck Regulator 5V V_{OUT} Demonstration Board

5. Revision History

Revision	Date	Description
1.00	Jan 9, 2024	Initial release

IMPORTANT NOTICE AND DISCLAIMER

RENESAS ELECTRONICS CORPORATION AND ITS SUBSIDIARIES (“RENESAS”) PROVIDES TECHNICAL SPECIFICATIONS AND RELIABILITY DATA (INCLUDING DATASHEETS), DESIGN RESOURCES (INCLUDING REFERENCE DESIGNS), APPLICATION OR OTHER DESIGN ADVICE, WEB TOOLS, SAFETY INFORMATION, AND OTHER RESOURCES “AS IS” AND WITH ALL FAULTS, AND DISCLAIMS ALL WARRANTIES, EXPRESS OR IMPLIED, INCLUDING, WITHOUT LIMITATION, ANY IMPLIED WARRANTIES OF MERCHANTABILITY, FITNESS FOR A PARTICULAR PURPOSE, OR NON-INFRINGEMENT OF THIRD-PARTY INTELLECTUAL PROPERTY RIGHTS.

These resources are intended for developers who are designing with Renesas products. You are solely responsible for (1) selecting the appropriate products for your application, (2) designing, validating, and testing your application, and (3) ensuring your application meets applicable standards, and any other safety, security, or other requirements. These resources are subject to change without notice. Renesas grants you permission to use these resources only to develop an application that uses Renesas products. Other reproduction or use of these resources is strictly prohibited. No license is granted to any other Renesas intellectual property or to any third-party intellectual property. Renesas disclaims responsibility for, and you will fully indemnify Renesas and its representatives against, any claims, damages, costs, losses, or liabilities arising from your use of these resources. Renesas' products are provided only subject to Renesas' Terms and Conditions of Sale or other applicable terms agreed to in writing. No use of any Renesas resources expands or otherwise alters any applicable warranties or warranty disclaimers for these products.

(Disclaimer Rev.1.01 Jan 2024)

Corporate Headquarters

TOYOSU FORESIA, 3-2-24 Toyosu,
Koto-ku, Tokyo 135-0061, Japan
www.renesas.com

Trademarks

Renesas and the Renesas logo are trademarks of Renesas Electronics Corporation. All trademarks and registered trademarks are the property of their respective owners.

Contact Information

For further information on a product, technology, the most up-to-date version of a document, or your nearest sales office, please visit www.renesas.com/contact-us/.