

ISL78220EVAL1Z: 6-Phase Interleaved Synchronous Boost Converter

ISL78220EVAL1Z Evaluation Board

The ISL78220EVAL1Z evaluation board features the ISL78220 6-phase interleaved boost controller and six ISL6609A MOSFET drivers. The ISL78220 and ISL6609A are configured as a 6-phase synchronous boost converter for 6-11V input into 12V output at 30A. The interleaved timing reduces input and output ripple current, thereby reducing the required number of input and output capacitors.

The ISL78220 enhances light load efficiency by dropping phases with decreasing load, by emulating a diode while stopping reverse current in the synchronous output switch, and by skipping switch pulses at very light loads. The ISL6609A facilitates diode emulation by translating the midrange of the tri-level PWM out from the ISL78220 to turn both output switches off.

For a 4-phase interleaved boost controller, please see the [ISL78225](#).

What's Inside

The evaluation board kit contains the following materials:

- The ISL78220EVAL1Z
- The ISL78220 Datasheet [FN7688](#)
- The ISL6609A Datasheet [FN9221](#)
- This Evaluation Board Kit document (AN1726)

Recommended Equipment

- 0V to 20V main power supply with at least 70A source current capability
- 12V electronic load capable of sinking up to 30A
- Digital Multimeters (DMMs)
- 100MHz Quad-Trace Oscilloscope

Quick Test Guide

1. Set main power supply to 6V, turn off, and connect to VIN and GND terminals on board.
2. Set electronic load for 1A, turn off, and connect to VOUT and GND terminals on board.
3. Turn on the main power supply.
4. Turn on the electronic load.
5. Adjust the main power supply in the range of 6V to 11V as desired.
6. Adjust the electronic load in the range of 0A to 30A as desired.
7. Turn off the main power supply.
8. Turn off the electronic load.

The default is phase dropping mode. For continuous switching mode, move shunt from JP14 to JP16 while the main power is turned off.

Application Note 1726

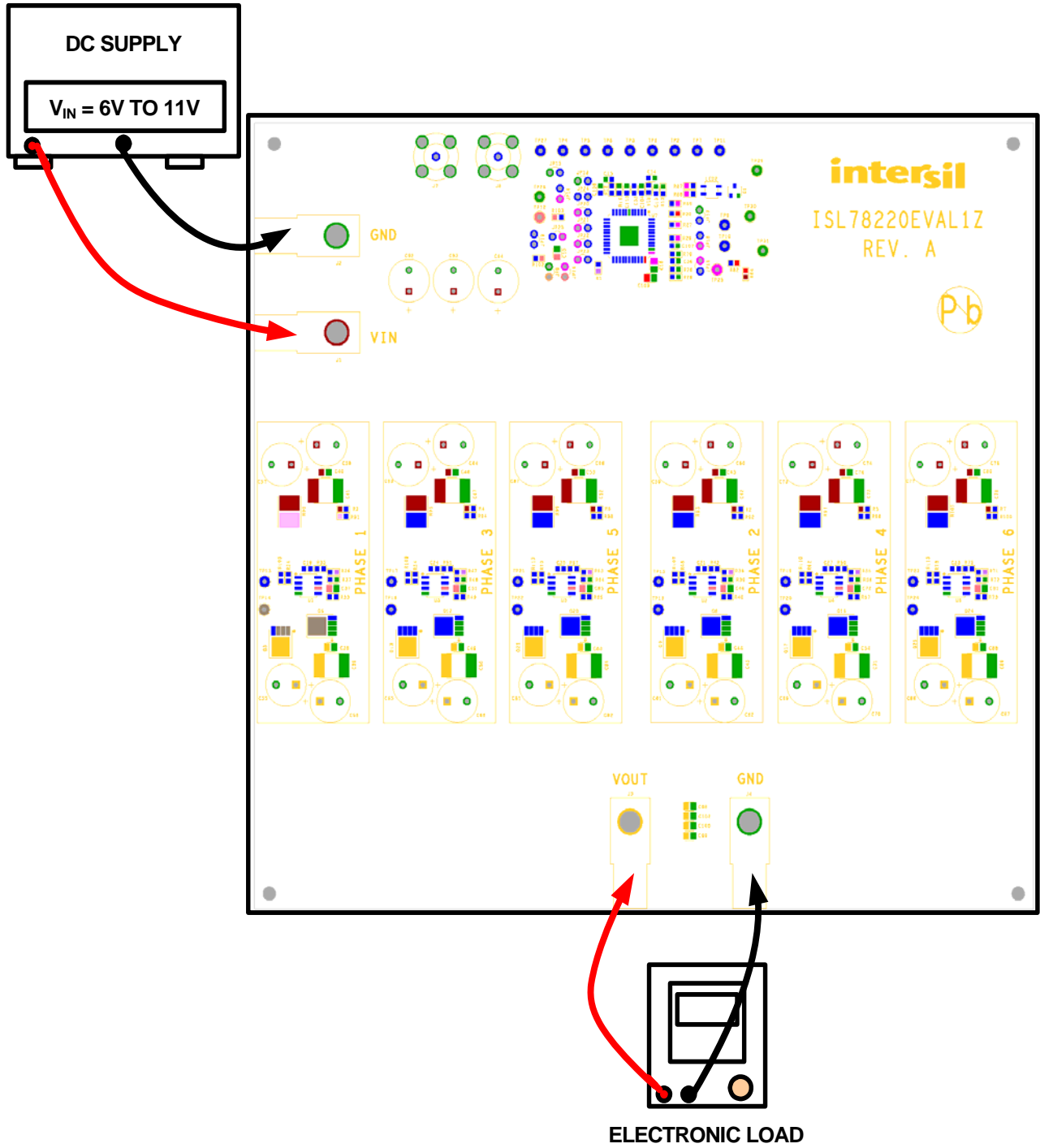

FIGURE 1. ISL78220EVAL1Z CONNECTIONS

Typical Performance Curves

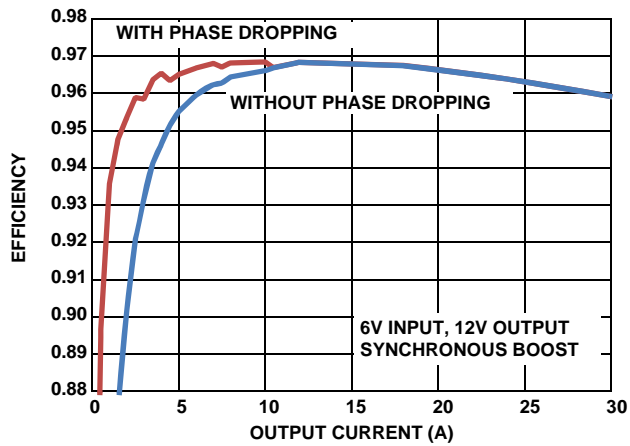

FIGURE 2. 6V INPUT EFFICIENCY vs OUTPUT CURRENT vs PHASE DROPPING MODE

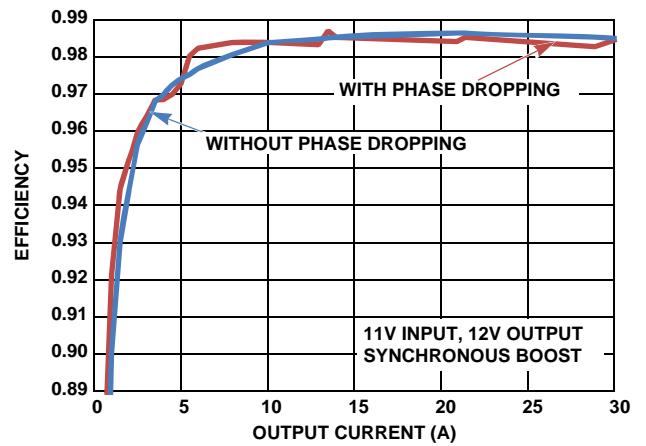

FIGURE 3. 11V INPUT EFFICIENCY vs OUTPUT CURRENT vs PHASE DROPPING MODE

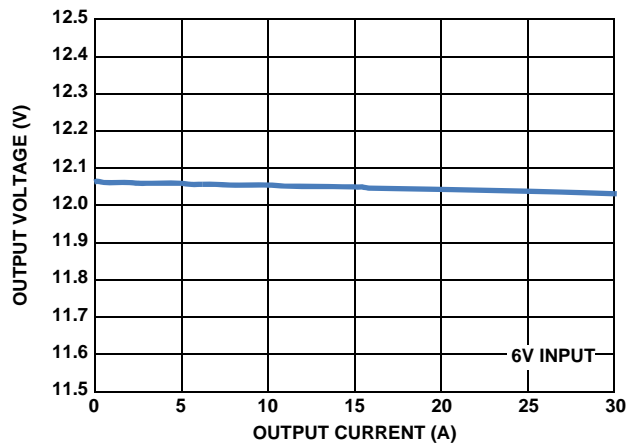

FIGURE 4. OUTPUT VOLTAGE vs OUTPUT CURRENT

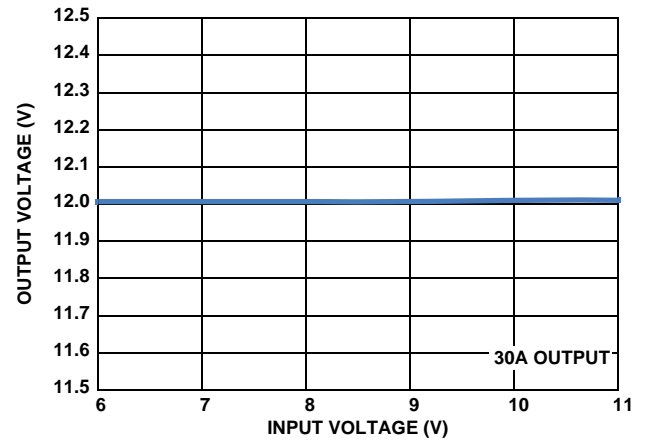

FIGURE 5. OUTPUT VOLTAGE vs INPUT VOLTAGE

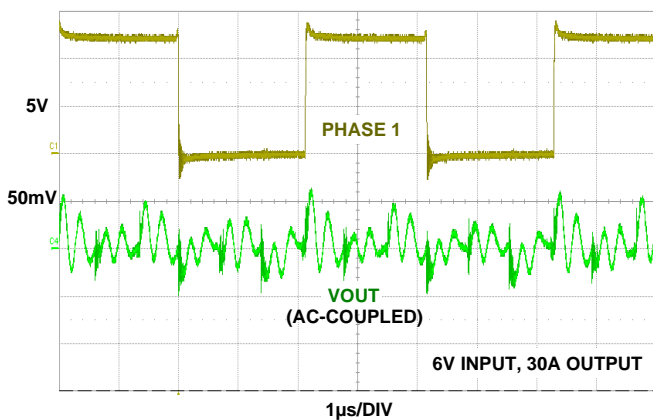

FIGURE 6. FULL LOAD OUTPUT RIPPLE

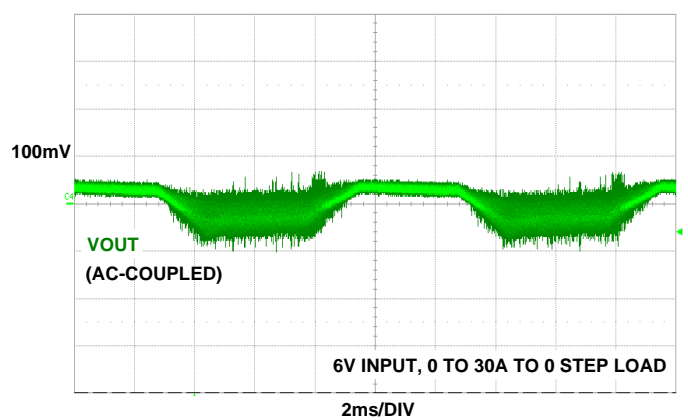

FIGURE 7. FULL STEP LOAD TRANSIENT

Schematics

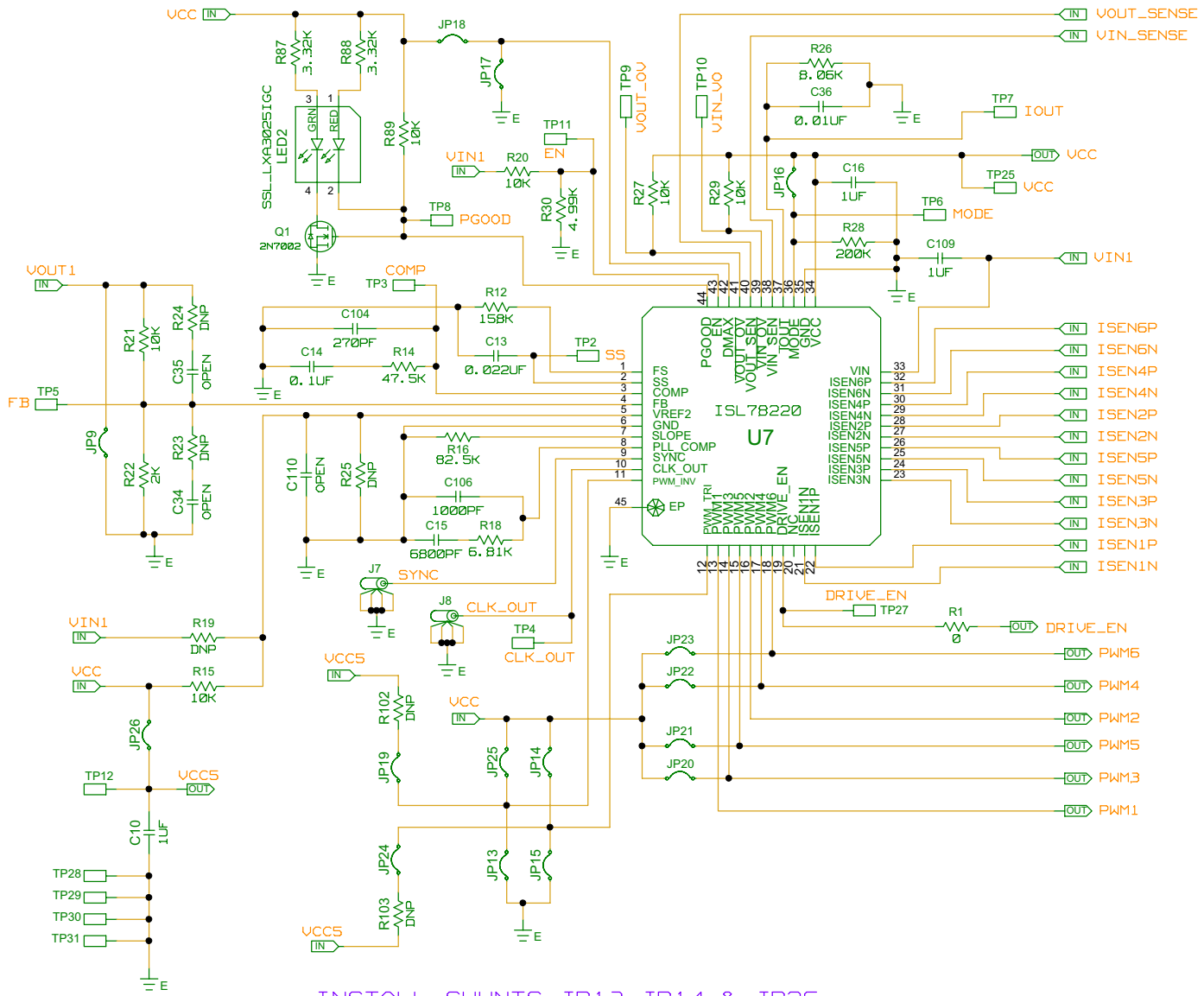

FIGURE 8. ISL78220EVAL12 SCHEMATIC PAGE 1

Schematics (Continued)

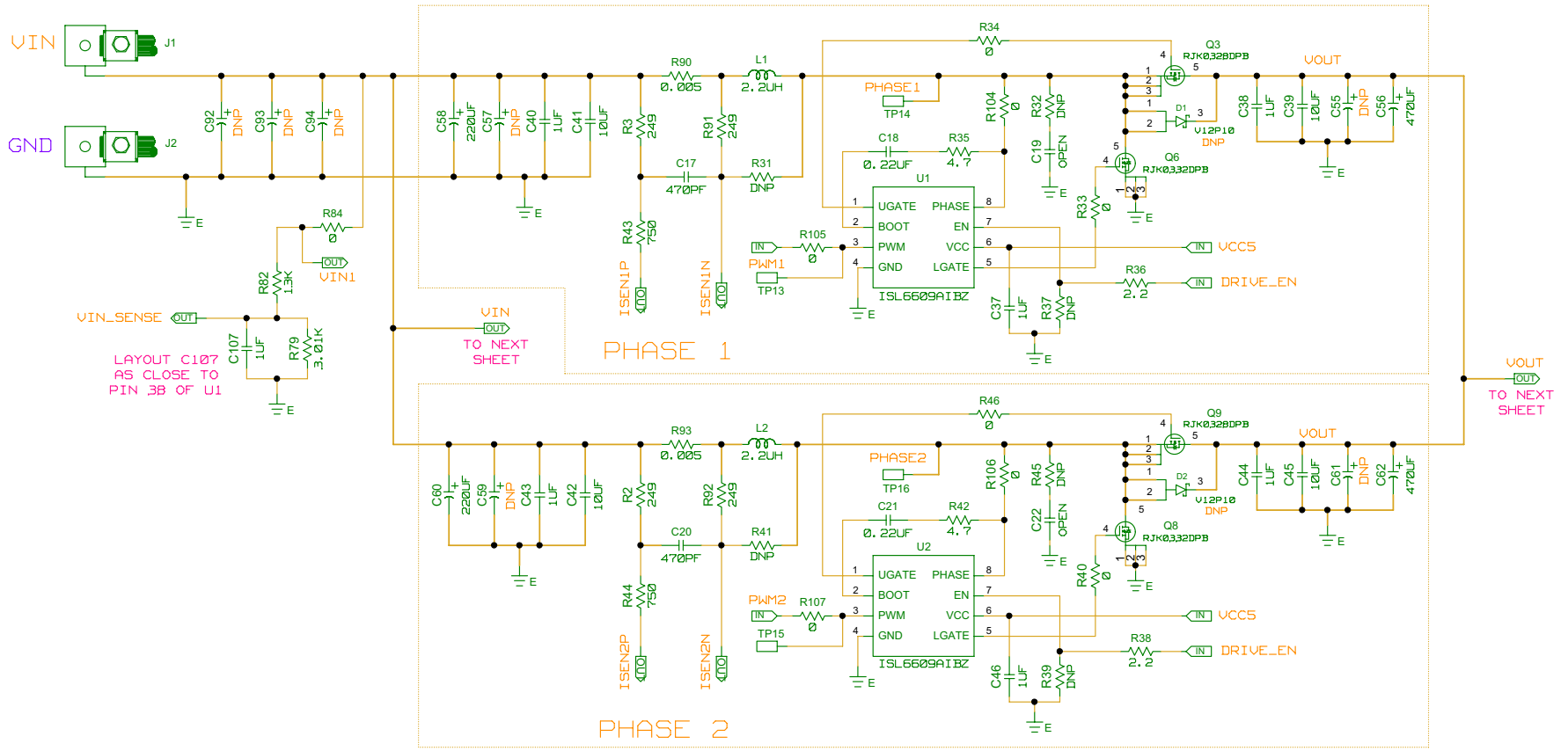

FIGURE 9. ISL78220EVAL1Z SCHEMATIC PAGE 2

Schematics (Continued)

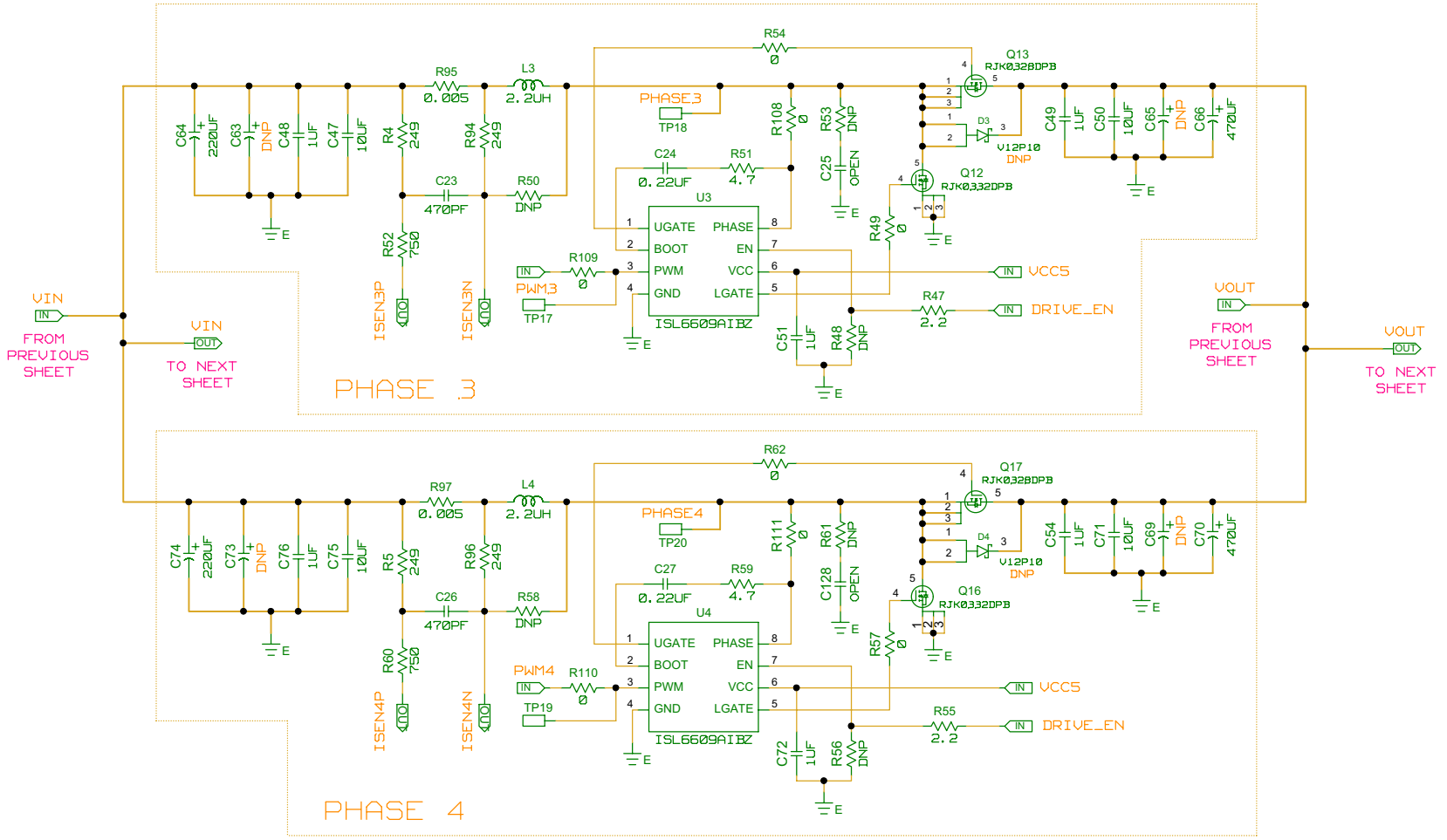

FIGURE 10. ISL78220EVAL1Z SCHEMATIC PAGE 3

Schematics (Continued)

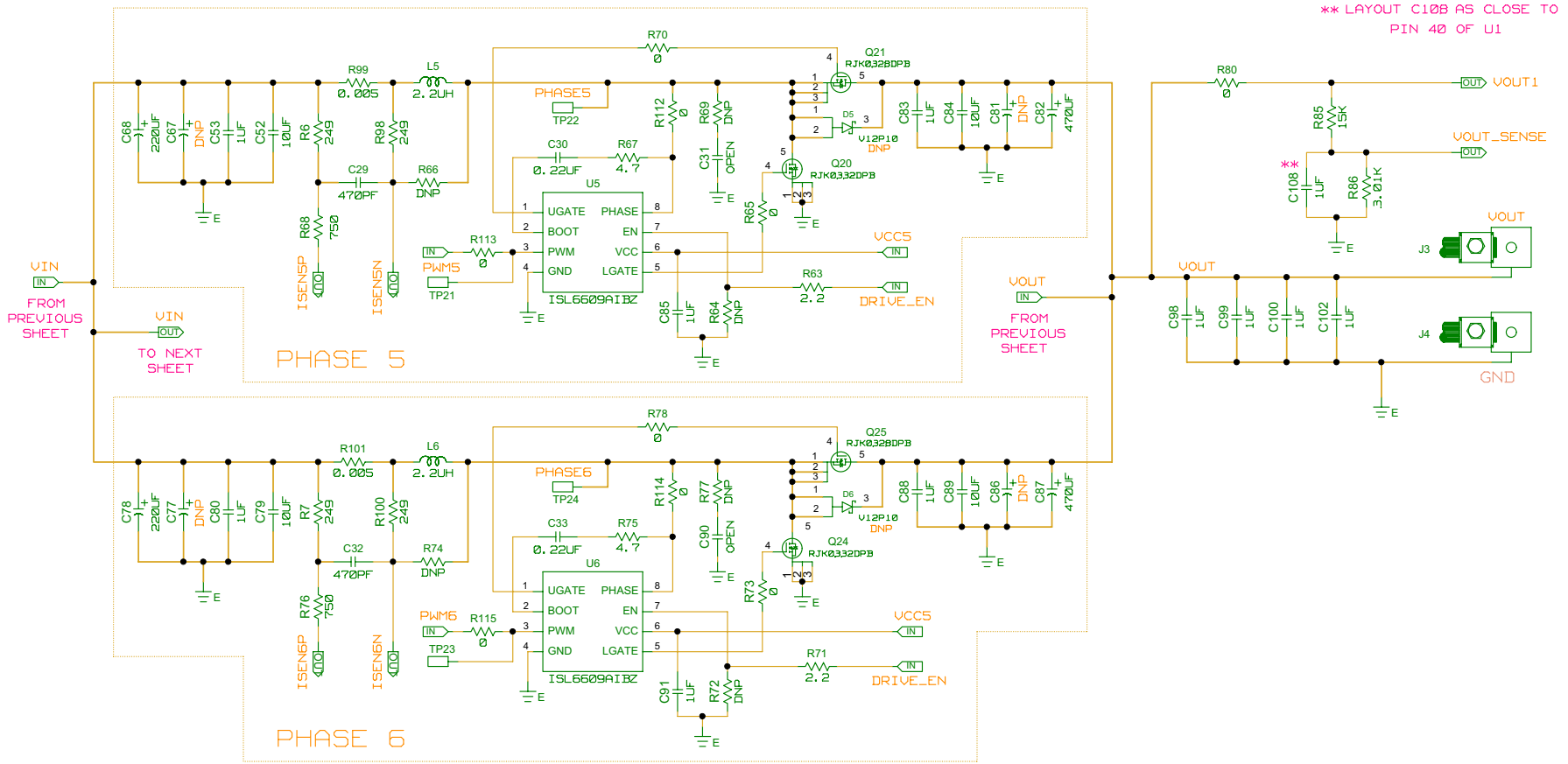

FIGURE 11. ISL78220EVAL1Z SCHEMATIC PAGE 4

Application Note 1726

TABLE 1. BILL OF MATERIALS

ITEM	QTY	PART REFERENCE	VALUE	DESCRIPTION	PART #	MANUFACTURER
1	24	C10, C37, C38, C40, C43, C44, C46, C48, C49, C51, C53, C54, C72, C76, C80, C83, C85, C88, C91, C98-C100, C102, C109	1 μ F	CAP Ceramic X7R, 50V, 0805	GRM21BR71H105KA12L	Murata
2	1	C13	0.022 μ F	CAP Ceramic X7R, 50V, 0603		Generic
3	1	C14	0.1 μ F	CAP Ceramic X7R, 25V, 0603		Generic
4	1	C15	6800pF	CAP Ceramic X7R, 50V, 0603		Generic
5	1	C16	4.7 μ F	CAP Ceramic X7R, 16V, 0805	GRM21BR71C475KA73L	Murata
6	4	C17, C20, C23, C26	470pF	CAP Ceramic X7R, 50V, 0603		Generic
7	4	C18, C21, C24, C27	0.22 μ F	CAP Ceramic X7R, 50V, 0603		Generic
8	1	C36	0.01 μ F	CAP Ceramic X7R, 16V, 0603		Generic
9	12	C39, C41, C42, C45, C47, C50, C52, C71, C75, C79, C84, C89	10 μ F	CAP Ceramic X7R, 50V, 2220	C5750X7R1H106K	TDK
10	6	C56, C62, C66, C70, C82, C87	470 μ F	Polymer CAP SEPC Series	16SEPC470M	Sanyo
11	6	C58, C60, C64, C68, C74, C78	220 μ F	Alum. Elec. CAP KY Series	EKY350ELL221MJC5S	United Chemi-con
12	1	C104	270pF	CAP Ceramic X7R, 50V, 0603		Generic
13	1	C106	1000pF	CAP Ceramic X7R, 50V, 0603		Generic
14	2	C107, C108	1 μ F	CAP Ceramic X7R, 16V, 0603	C1608X7R1C105K	TDK
15	4	J1-J4		Wire Connector Lug	KPA8CTP	Burndy
16	2	J7, J8		50 Ω PCB MOUNT RECEPTACLE	31-5329-52RFX	Amphenol
17	15	JP9, JP13-JP26		Two Pin 0.1" Jumper		Generic
18	4	L1-L4	2.2 μ H	LOW PROFILE HIGH CURRENT INDUCTOR (RoHS COMPLIANT)	IHLP-6767GZ-ER-2R2-M-01	Vishay
19	1	LED2		3x2.5mm Surface Mount RED/GREEN LED	SSL-LXA3025IGC	Lumex
20	1	Q1		N-Channel 60V 115ma MOSFET	2N7002L	On Semi
21	6	Q3, Q9, Q13, Q17, Q21, Q25		N-Channel 30V 60A Power MOSFET	RJK0328DPB	Renesas
22	6	Q6, Q8, Q12, Q16, Q20, Q24		N-Channel 30V 35A Power MOSFET	RJK0332DPB	Renesas
23	27	R1, R33, R34, R40, R46, R49, R54, R57, R62, R65, R70, R73, R78, R80, R84, R104-R115	0 Ω	Resistor, 1% 0603		Generic
24	12	R2-R7, R91, R92, R94, R96, R98, R100	249 Ω	Resistor, 1% 0603		Generic
25	1	R12	158k Ω	Resistor, 1% 0603		Generic
26	1	R14	47.5k Ω	Resistor, 1% 0603		Generic

Application Note 1726

TABLE 1. BILL OF MATERIALS (Continued)

ITEM	QTY	PART REFERENCE	VALUE	DESCRIPTION	PART #	MANUFACTURER
27	6	R15, R20, R21, R27, R29, R89	10kΩ	Resistor, 1% 0603		Generic
28	1	R16	82.5kΩ	Resistor, 1% 0603		Generic
29	1	R18	6.81kΩ	Resistor, 1% 0603		Generic
30	1	R22	2kΩ	Resistor, 1% 0603		Generic
31	1	R28	200kΩ	Resistor, 1% 0603		Generic
32	1	R30	4.99kΩ	Resistor, 1% 0603		Generic
33	6	R35, R42, R51, R59, R67, R75	4.7Ω	Resistor, 5% 0603		Generic
34	6	R36, R38, R47, R55, R63, R71	2.2Ω	Resistor, 5% 0603		Generic
35	6	R43, R44, R52, R60, R68, R76	750Ω	Resistor, 1% 0603		Generic
36	2	R79, R86	3.01kΩ	Resistor, 1% 0603		Generic
37	1	R82	13.0kΩ	Resistor, 1% 0603		Generic
38	1	R85	15.0kΩ	Resistor, 1% 0603		Generic
39	2	R87, R88	3.32kΩ	Resistor, 1% 0603		Generic
40	6	R90, R93, R95, R97, R99, R101	0.005Ω	SURFACE MOUNT POWER METAL STRIP RESISTOR, 1%	WSH28185L000FE	Vishay
41	29	TP2-TP25, TP27-TP31		Miniature White Test Point .100 Pad .040 Thole	5002	Keystone
42	6	U1-U6		Synchronous Rectified MOSFET Driver	ISL6609AIBZ	Intersil
43	1	U7		SIX-PHASE BOOST PWM CONTROLLER (Pb-FREE)	ISL78220ANEZ	Intersil

ISL78220EVAL1Z Board Layout

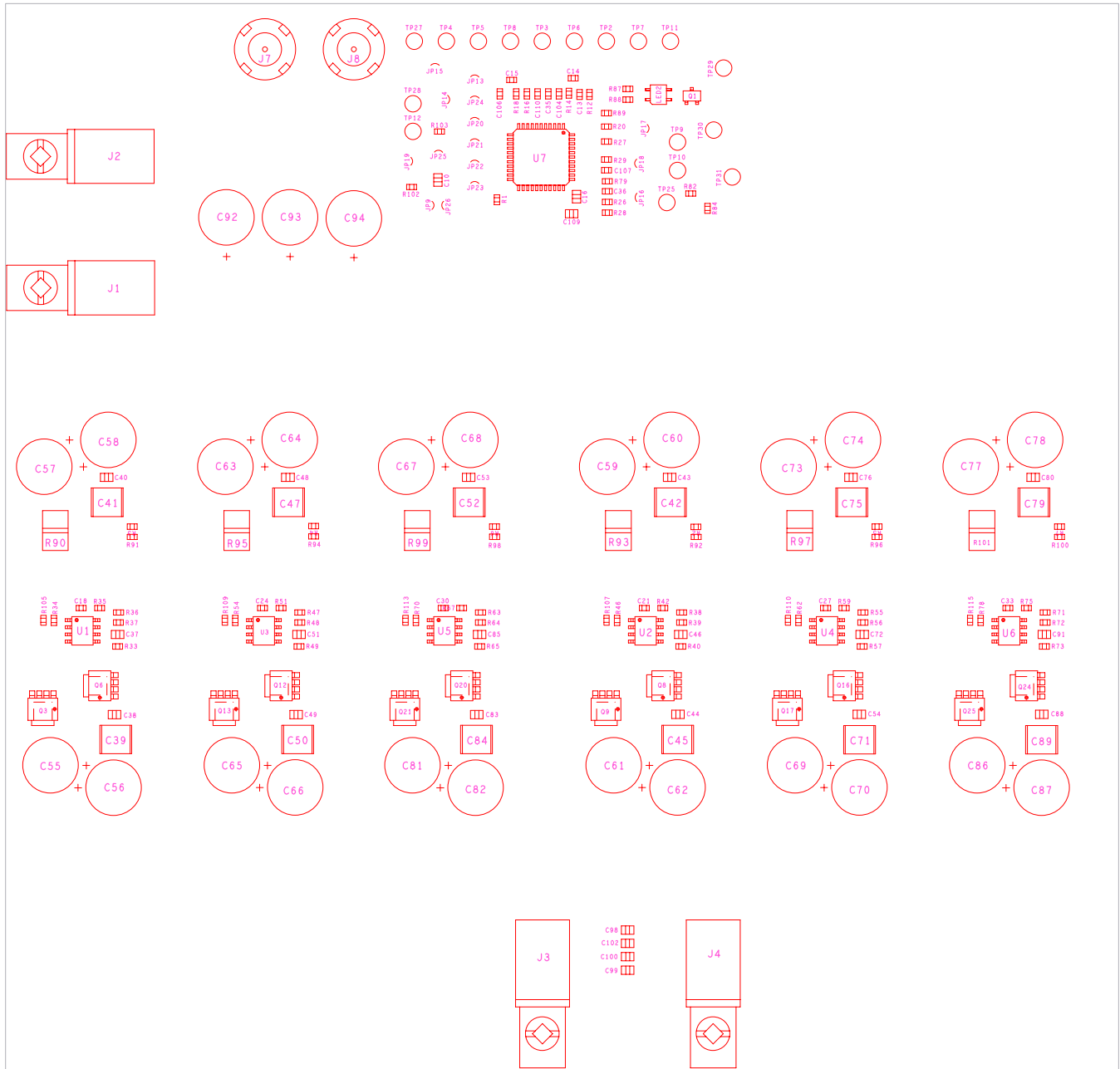

FIGURE 12. ASSEMBLY TOP

ISL78220EVAL1Z Board Layout (Continued)

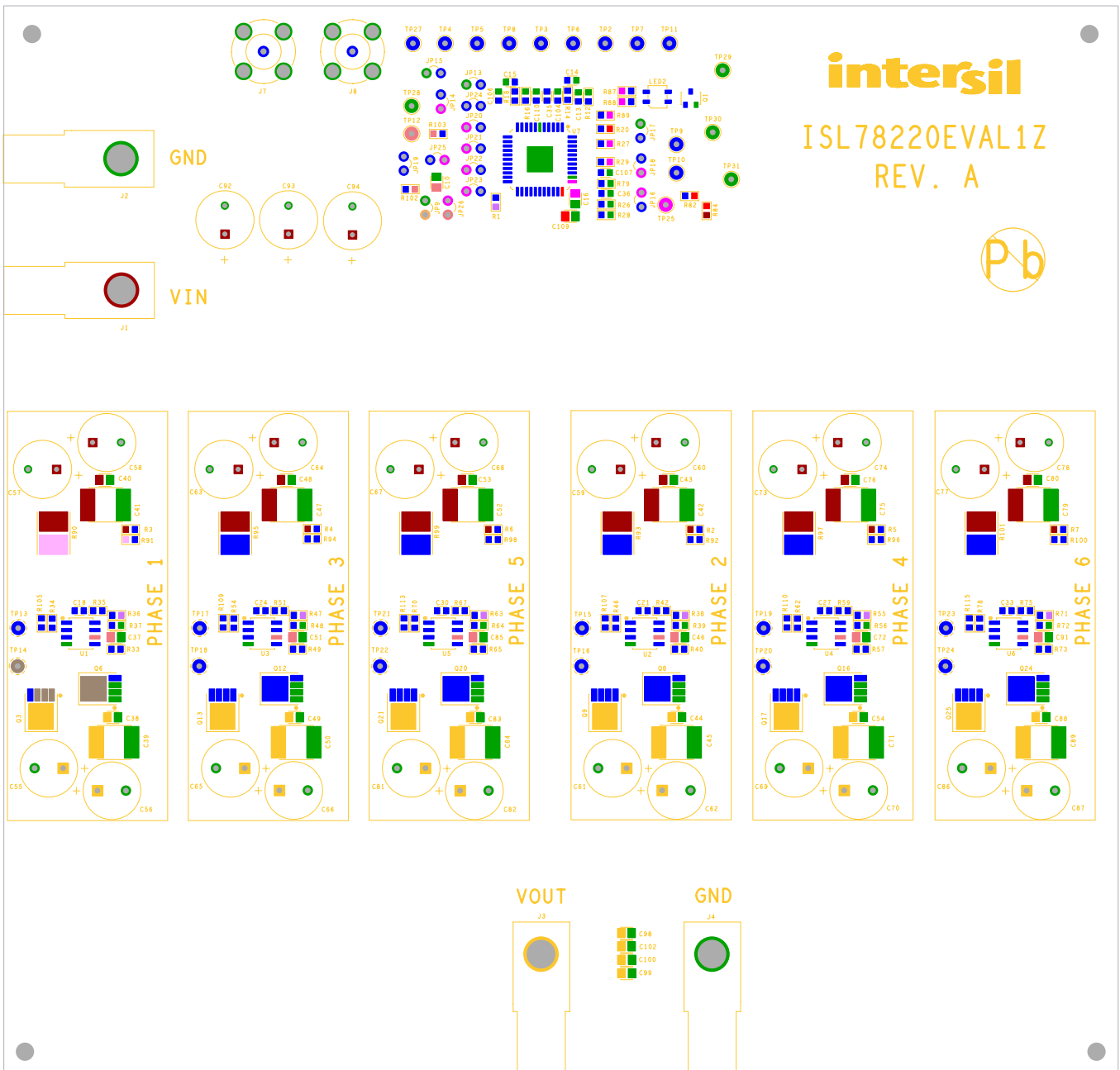

FIGURE 13. SILK SCREEN TOP

ISL78220EVAL1Z Board Layout (Continued)

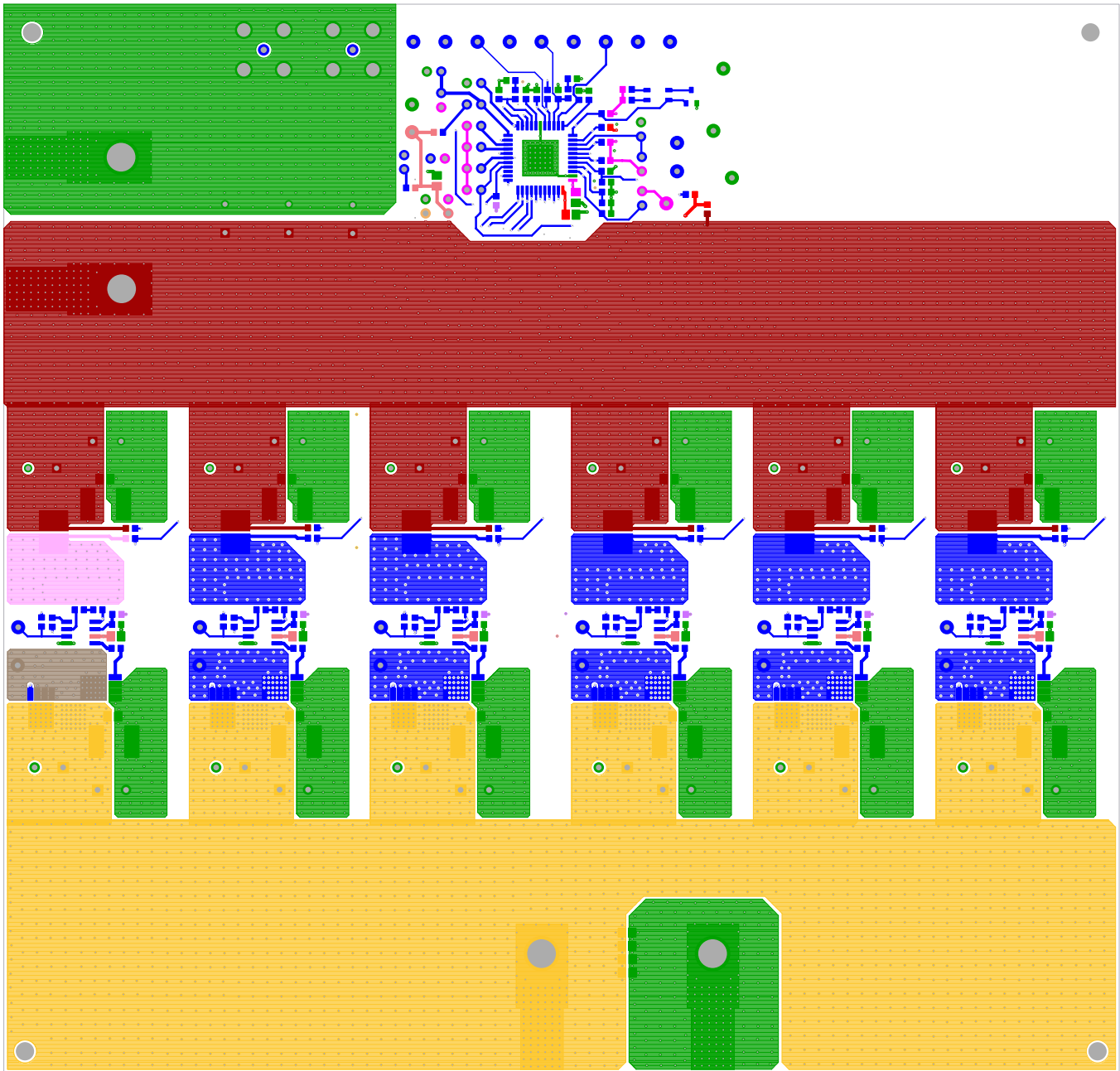

FIGURE 14. TOP LAYER COMPONENT SIDE

ISL78220EVAL1Z Board Layout (Continued)

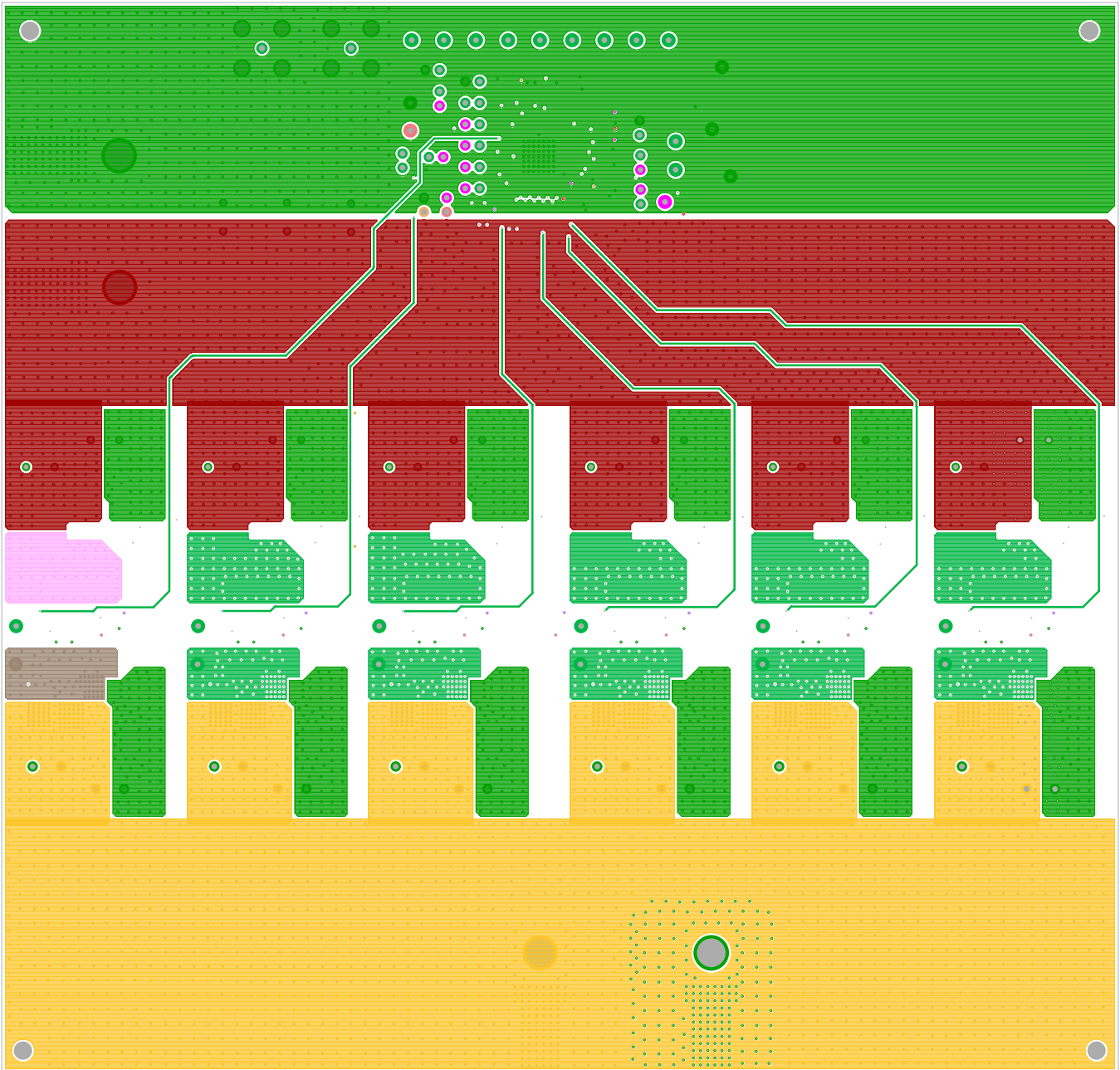

FIGURE 15. LAYER 2

ISL78220EVAL1Z Board Layout (Continued)

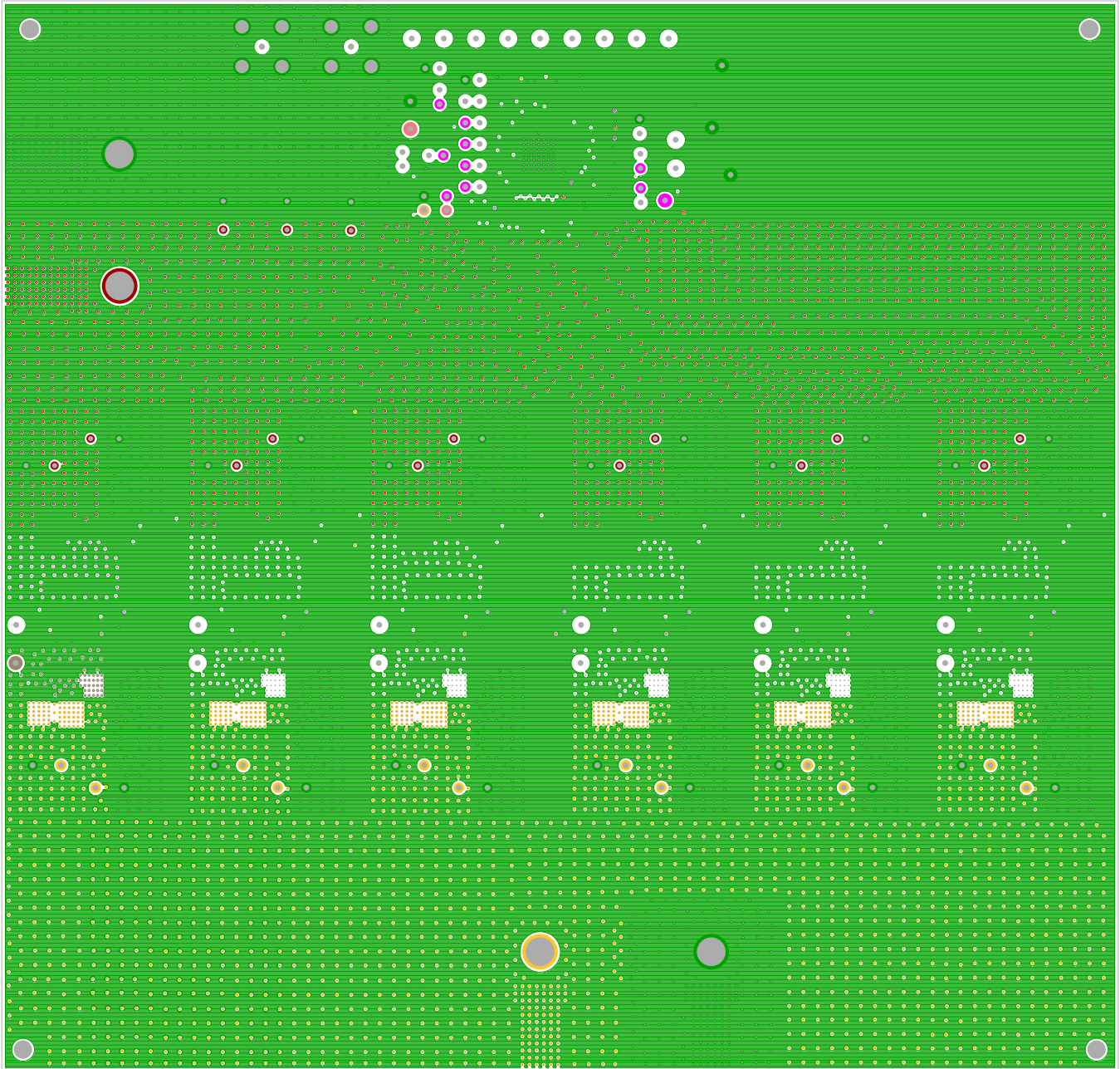

FIGURE 16. LAYER 3

ISL78220EVAL1Z Board Layout (Continued)

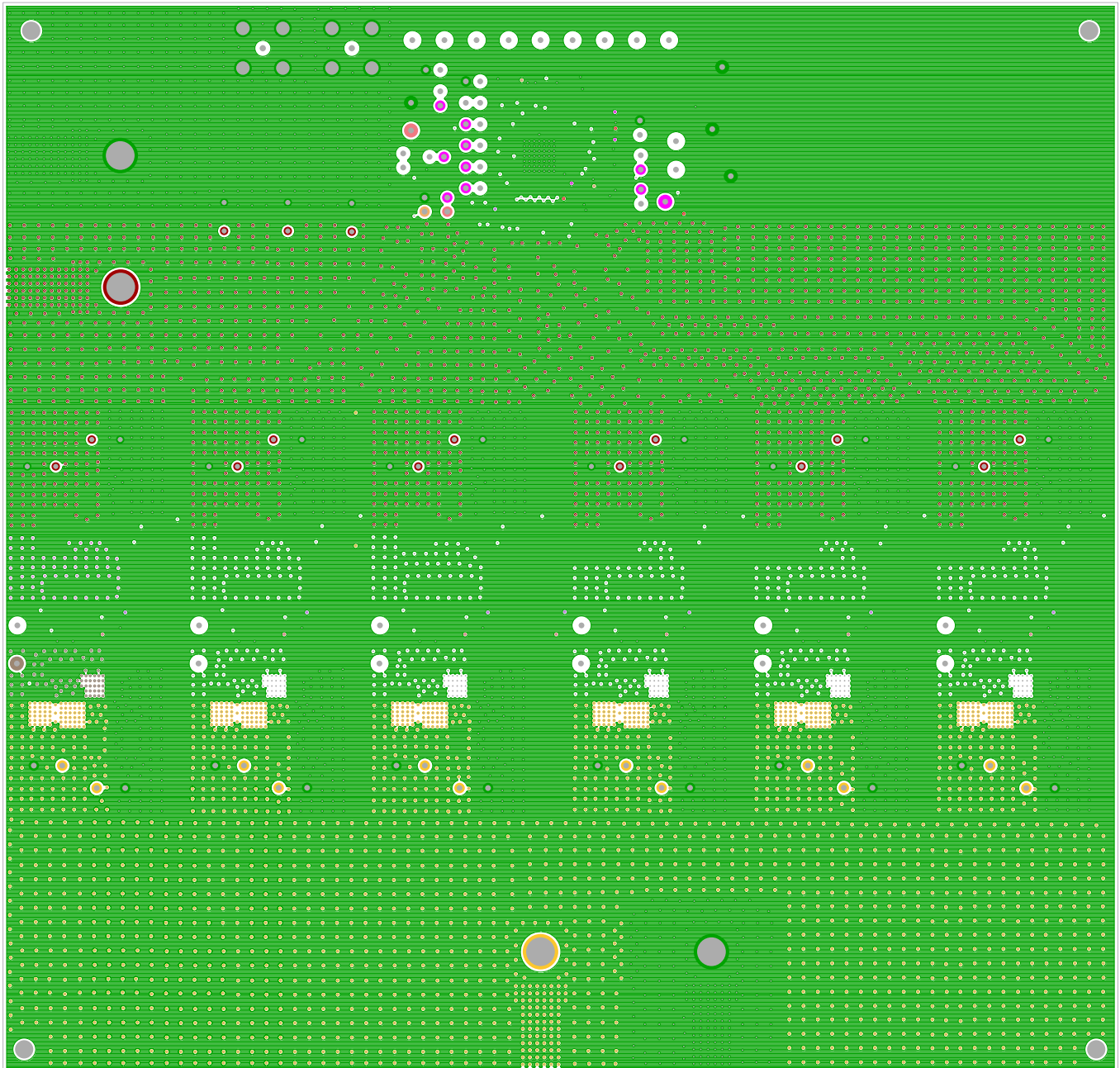

FIGURE 17. LAYER 4

ISL78220EVAL1Z Board Layout (Continued)

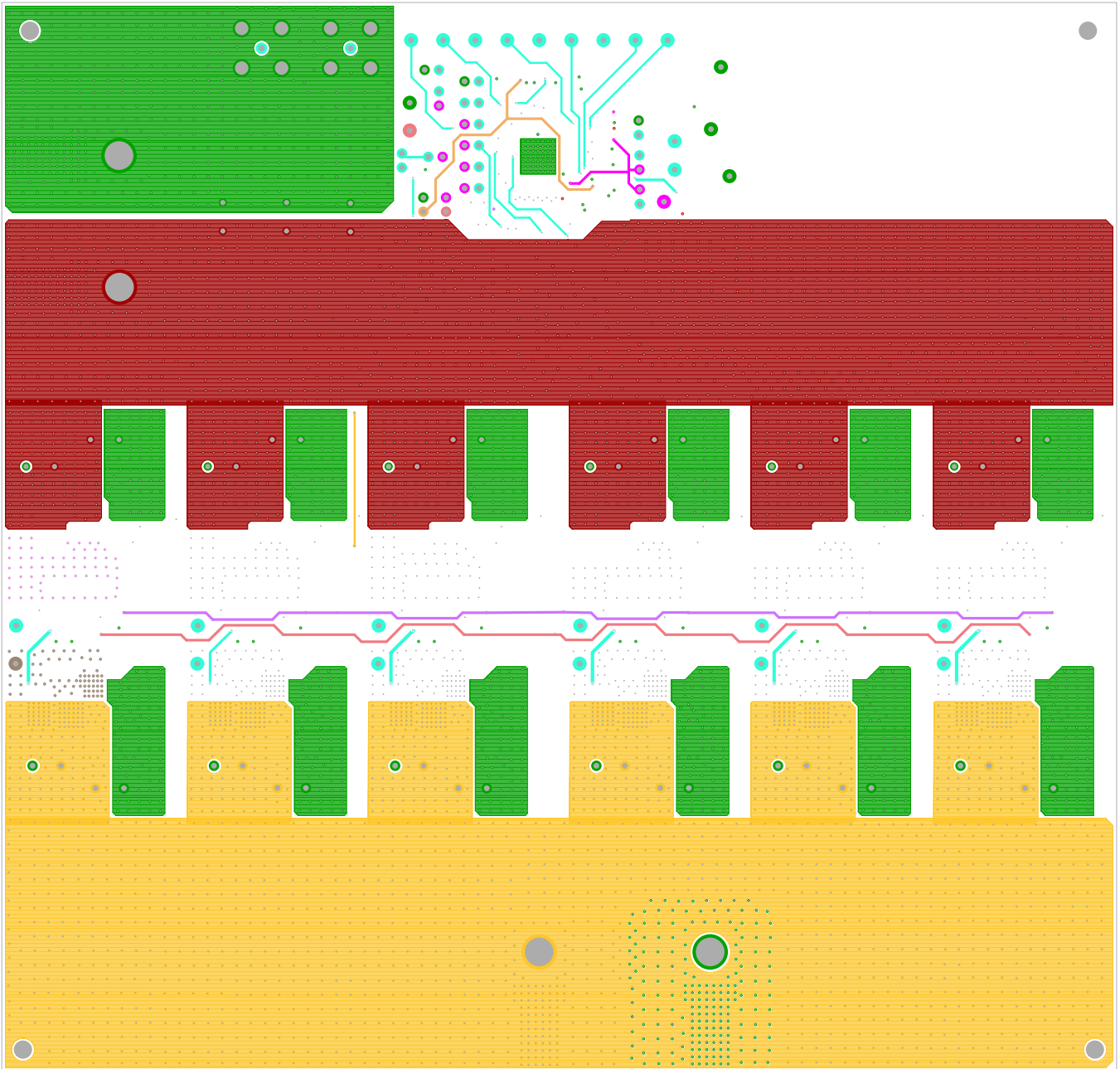

FIGURE 18. LAYER 5

ISL78220EVAL1Z Board Layout (Continued)

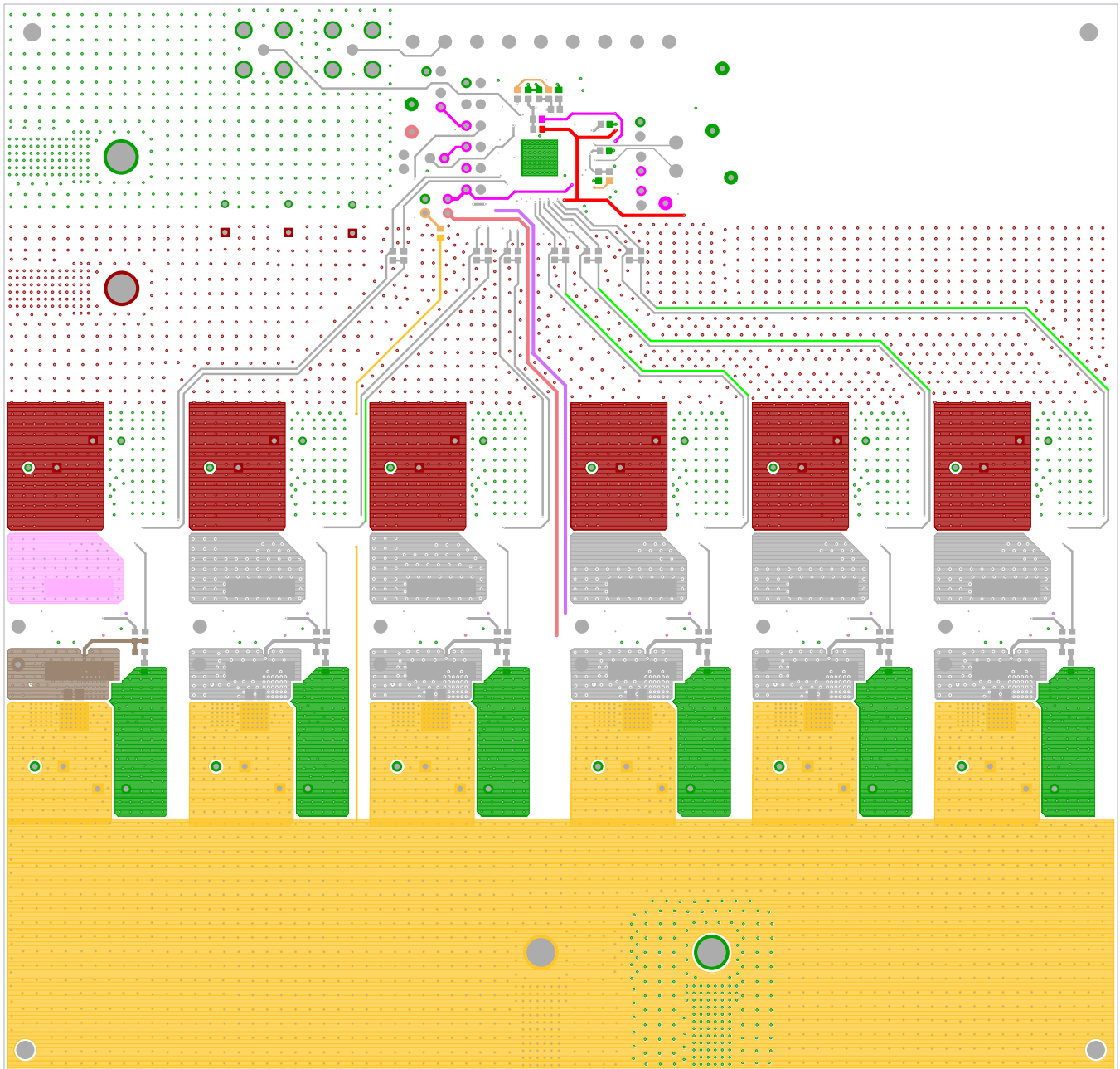

FIGURE 19. BOTTOM LAYER SOLDER SIDE

ISL78220EVAL1Z Board Layout (Continued)

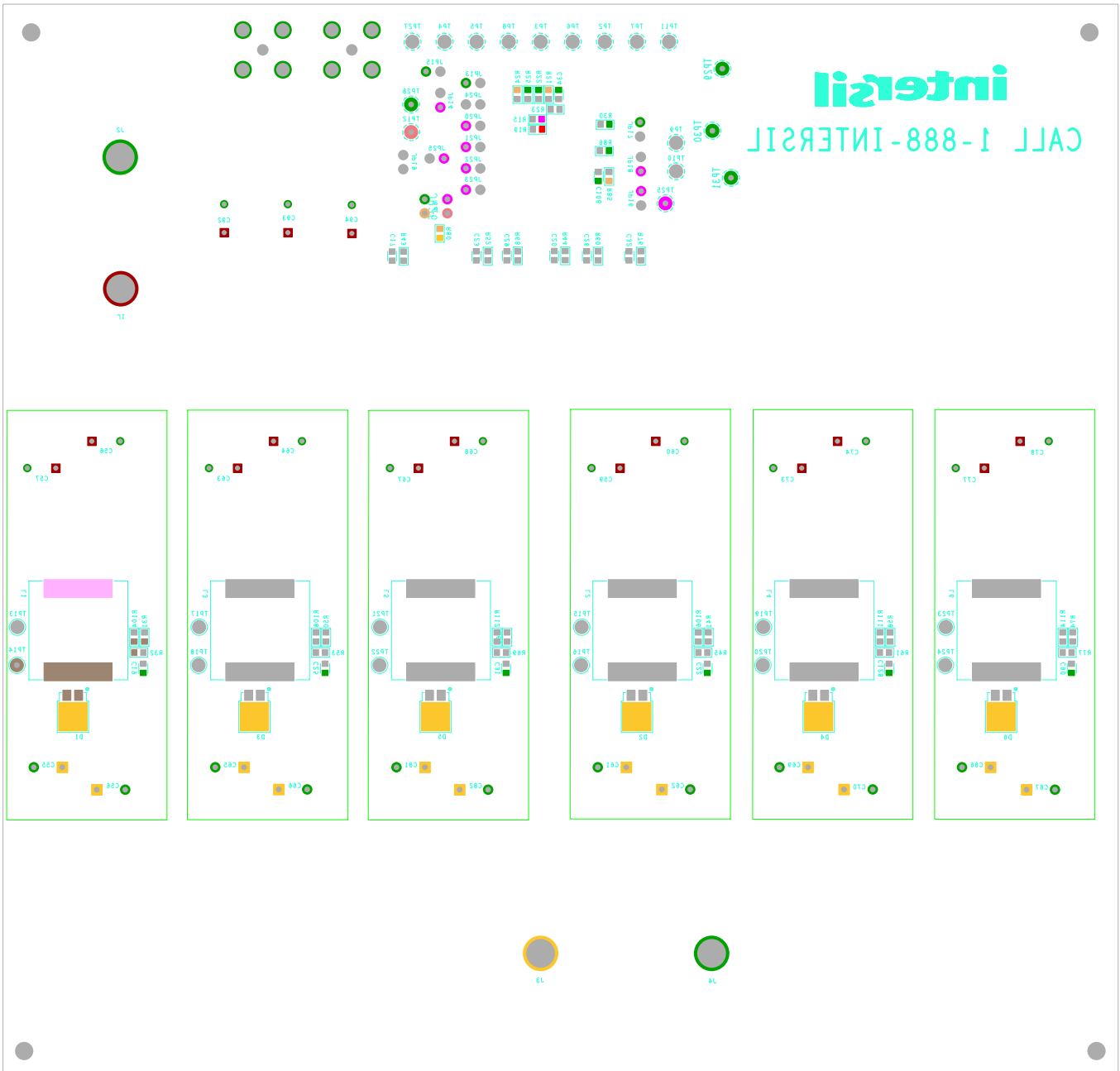

FIGURE 20. SILK SCREEN BOTTOM

ISL78220EVAL1Z Board Layout (Continued)

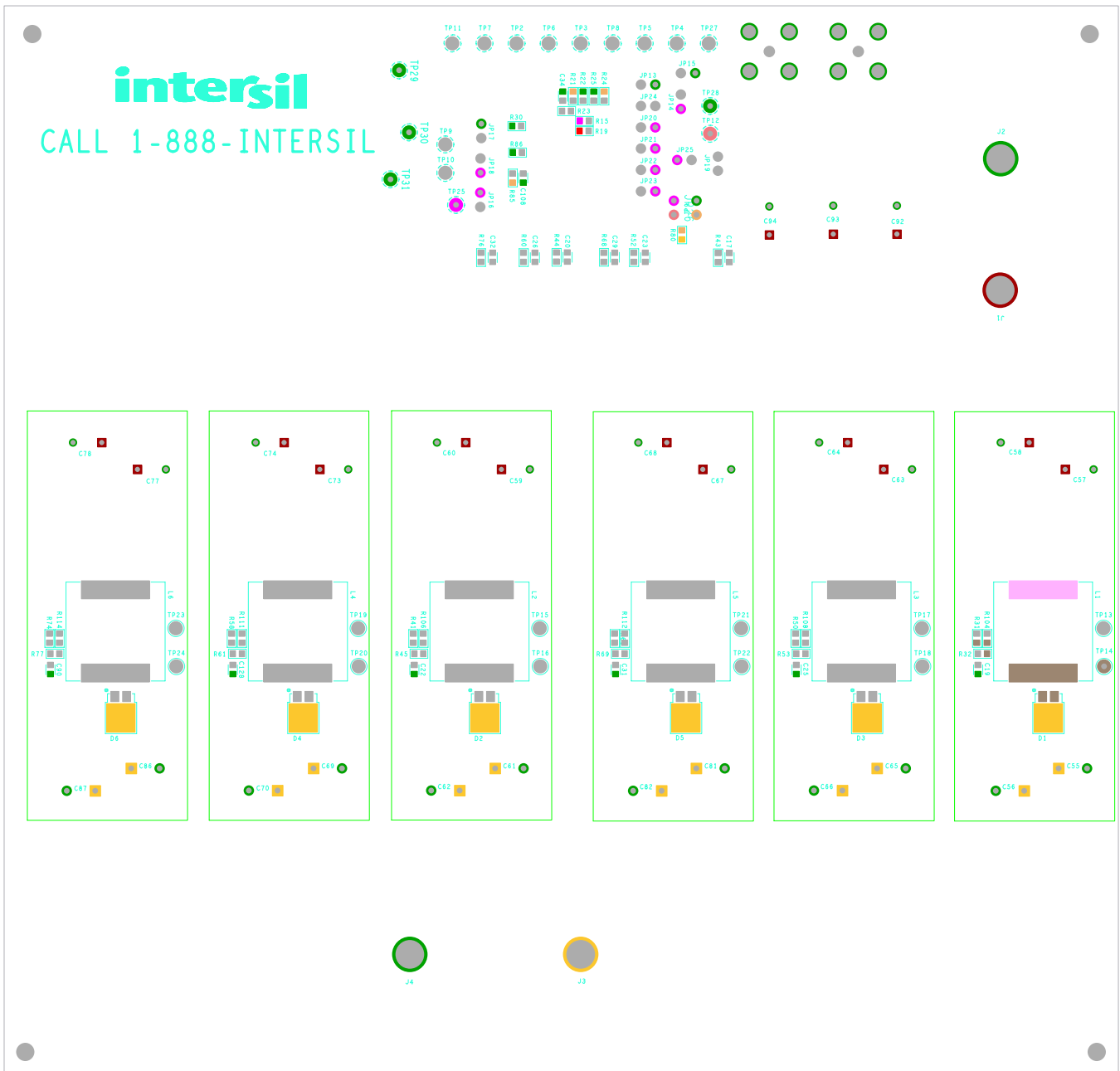

FIGURE 21. SILK SCREEN BOTTOM (MIRRORED)

ISL78220EVAL1Z Board Layout (Continued)

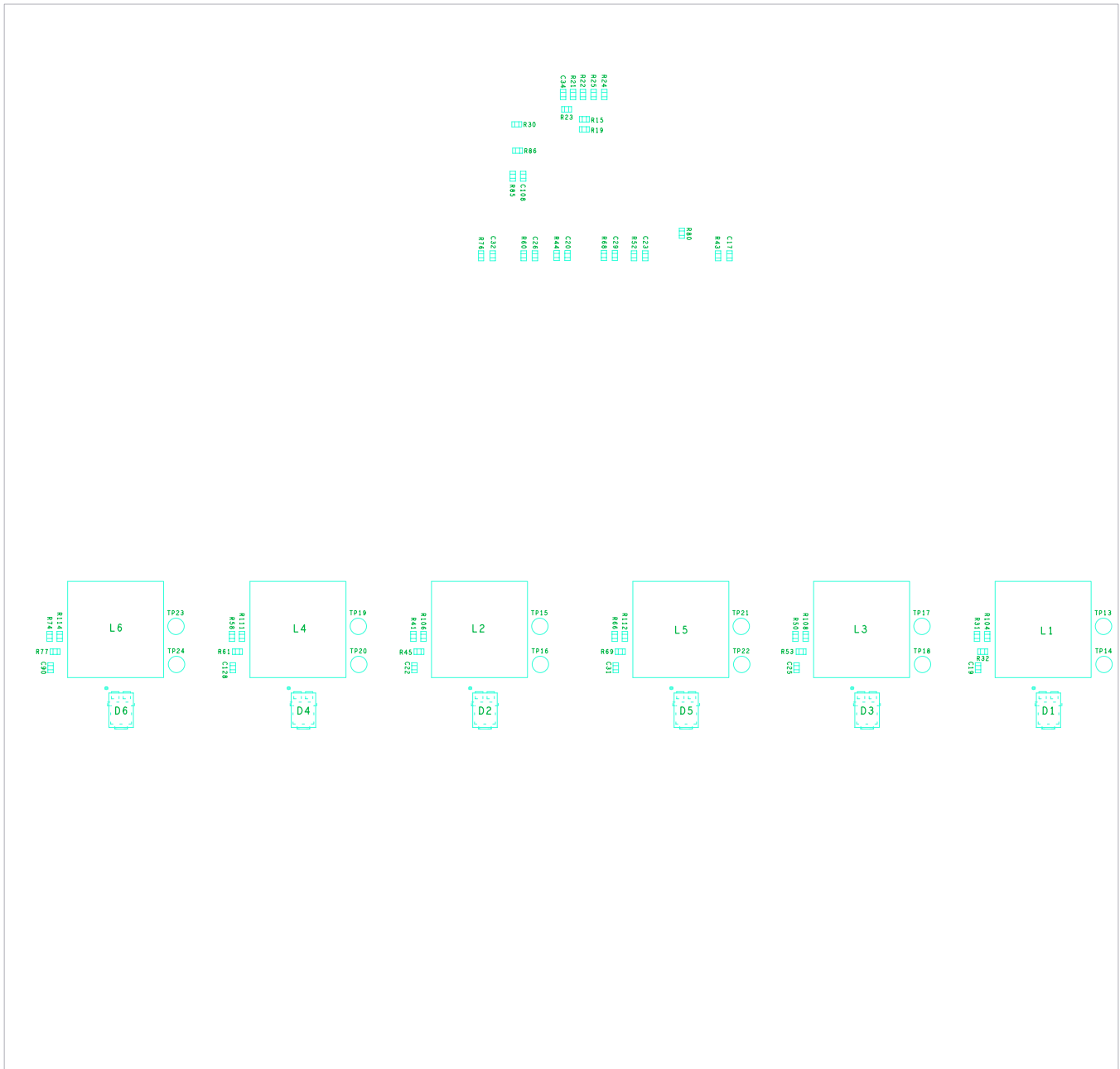

FIGURE 22. ASSEMBLY BOTTOM

Intersil Corporation reserves the right to make changes in circuit design, software and/or specifications at any time without notice. Accordingly, the reader is cautioned to verify that the Application Note or Technical Brief is current before proceeding.

For information regarding Intersil Corporation and its products, see www.intersil.com