

## Complete Amplifier Evaluation System

- TXS25-4: 4-Channel Digital Amplifier
- Single Power Supply (+25V) Operation
- Internally Generated Negative Rail High-voltage Supply (-25V)
- Internally Generated and Regulated Low-voltage Supplies (+5V/+3.3V/1.8V)
- D2Audio Canvas II™ Installation CD-ROM (includes USB Driver and D2Audio Canvas II User's Guide)
- Detachable Digital/Analog Audio/Control I/O and Power Assembly Boards
- "SCAMP III" Header Pins on Digital/Analog Audio/Control I/O Board Enables In-system Firmware Upgradeability
- Optical (TOSLINK) and Coax Digital S/PDIF Inputs that Accept an IEC60958 Compliant Interconnect Carrying Linear PCM with an Fs of 32kHz~192kHz
- Optical (TOSLINK) Digital S/PDIF Output
- 4 Channels of Analog Audio Inputs Using High-Performance 4-Channel Analog-to-Digital Converter (ADC)
- 2 I<sup>2</sup>S/Left-Justified Digital Audio Input Headers
- 2 I<sup>2</sup>S/Left-Justified Digital Audio Output Headers
- Rotary Knob Connected to GPIO Lines Enables Simple Master Volume Control for Channels 1 and 2
- Subwoofer Analog Audio Output (Passive Filtered PWM Line Level Output)
- High-Quality Speaker Banana-Jack Connectors

## D2Audio Canvas II™ GUI Simplifies System Design

- Intuitive, "Point-and-click" Audio-Centric User Interface Simplifies Evaluation of All Audio Processing Configurations
- Configuration for Stereo, Dual Zone, Stereo Bi-Amp or Powered 2.1 Systems Takes Less than a Minute

## Selectable DSP Processing Functions

- Input Selection (Analog, S/PDIF, I<sup>2</sup>S/Left-Justified)
- 4 Independent Channels of Audio Processing
  - Tone Control
  - Matrix Mixing
  - Programmable Crossover with Butterworth, Linkwitz/Riley, Bessel Filter Types
  - 5-Band and 3-Band Parametric EQ
  - Master Volume Control
  - Loudness Contour
  - Individual Channel Time Delay
  - Per Channel Dynamic Range Compression/Limiting
  - Independent Channel Level Controls - Enables Independent Level Control for Amplified Channels 1, 2, 3 and 4 Outputs as well as Digital Audio Outputs

## D2Audio SoundSuite™ Immersive Processing

- Mono2Stereo™
- WideSound™
- DeepBass™
- AudioAlign™

The TXS25-4 Evaluation Kit is a complete amplifier evaluation system for the TXS25-4 digital amplifier module. Audio system designers can quickly evaluate all of the features and functions of the TXS25-4 design with this system.

This system offers the ultimate in configurations, digital/analog I/O and power supply connection. It offers headers for all digital audio inputs and outputs so that the system designer can quickly and easily "wire-wrap" into the board. This enables any I<sup>2</sup>S/Left-Justified digital audio source to be delivered from any digital audio source such as an HDMI™ receiver or a Media Networking Processor and input into the TXS25-4 amplifier with minimum effort. A header is also offered for the control communication bus (2-wire interface), which enables fast connection of a system microcontroller for rapid prototyping.

The D2Audio Canvas GUI software simplifies system design with an intuitive, audio-centric user interface with "point-and-click" options on a Windows™ PC. Organized processing blocks are included for audio input selection, Tone Control, Crossovers, Parametric Equalizers, Adjustable Time Delay, Signal Limiter/Compressor, Volume Control, Loudness Contour, and Independent Level Control.

### **TXS25-4 Evaluation Kit**

- Complete Evaluation Platform for TXS25-4
- 4 Channels of Amplified Speaker Outputs
- 4 Channels of Analog Inputs
- 4 Channels of Digital Audio Inputs (1 S/PDIF and 2 x I<sup>2</sup>S/Left-Justified Inputs)
- 4 Channels of Digital Audio Inputs (1 S/PDIF and 2 x I<sup>2</sup>S/Left-Justified Outputs)
- All necessary voltages are generated from single +25V power source reducing cost and complexity of the system power supply
- Internally Regulated Low-voltage supplies (+5V/+3.3V/1.8V)
- Master Volume Knob (Channels 1 and 2)

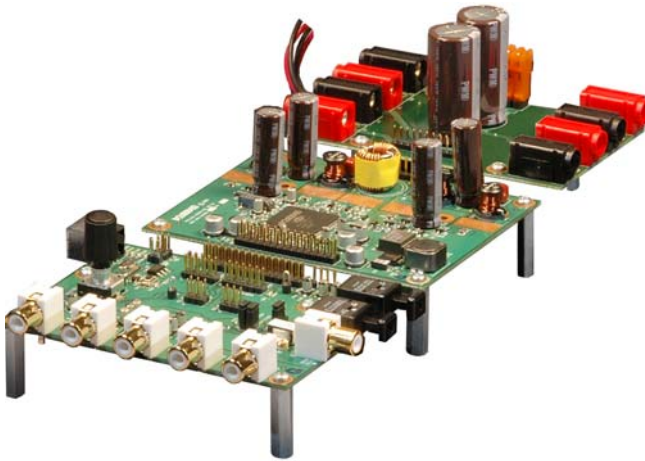

Getting Started



**WARNING**

This symbol is used to warn operators that uninsulated “dangerous voltages” are present within this equipment that may impose risk of electrical shock

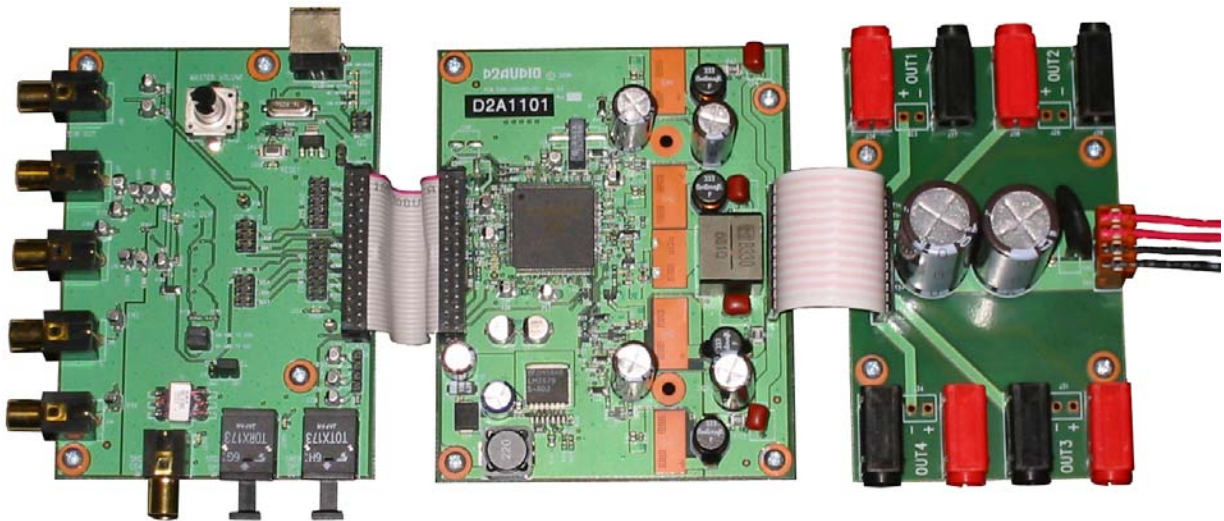

FIGURE 1. TSX25-4 AMPLIFIER BOARDS

**Overview**

The TSX25-4 Amplifier evaluation kit consists of 3 boards. These boards, shown in Figure 1, consist of the main amplifier board, an input board, and an output board. Each of these 3 boards are shown in detail in Figures 2, 3, and 4. Ribbon cables (supplied) interconnect the 3 boards.

The system can be configured either through software (refer also to D2Audio Canvas II Software Configuration Documentation found on the D2Audio Canvas II Software CD) or configured by hardware settings (see “Input Source Options” on page 17).

**Platform Configurations**

The TSX25-4 Amplifier kit may be configured as a stereo amplifier with a single or multiple inputs, and is also capable of providing a summed and low-pass filtered output which can then be sent to an external powered subwoofer. The flexible signal processing flow and extensive digital audio inputs and outputs of the TSX25-4 also allows for processed output to be connected (as on this evaluation platform) to an external DAC to enable post-processed Line-Level Outputs or Headphone Outputs.

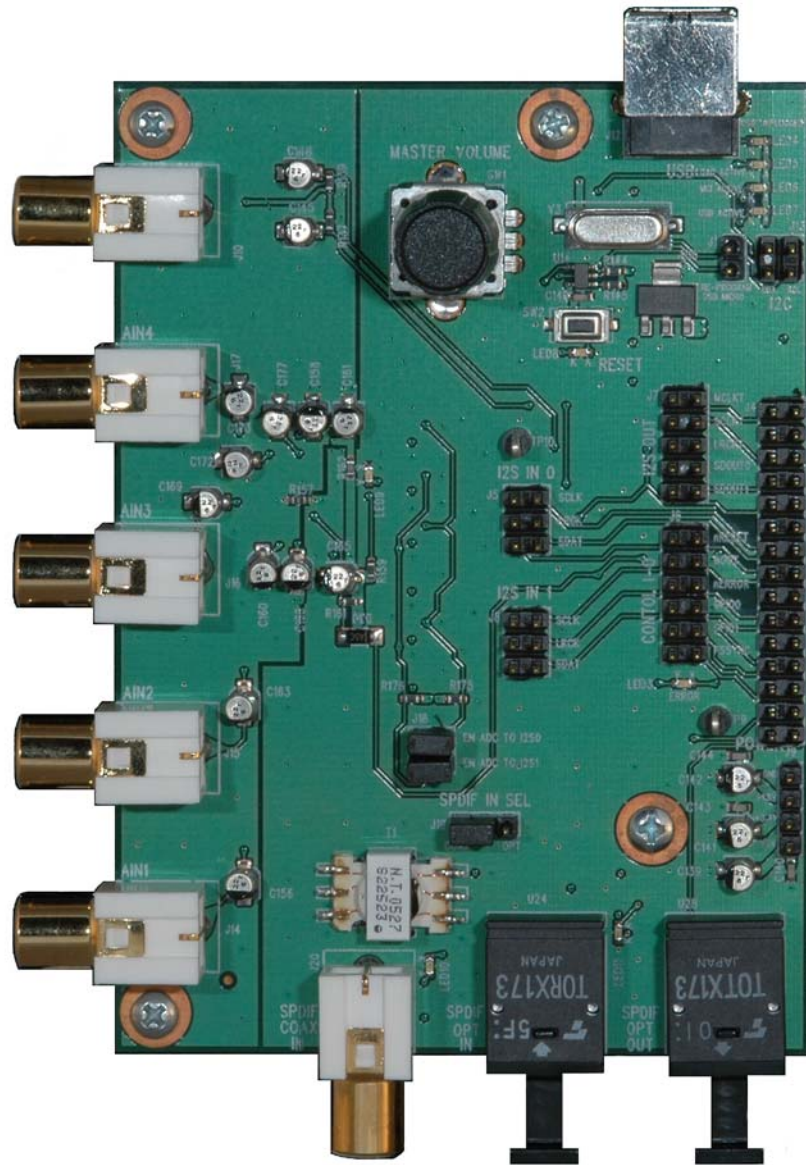

FIGURE 2. DIGITAL/ANALOG AUDIO/CONTROL I/O BOARD - TOP VIEW



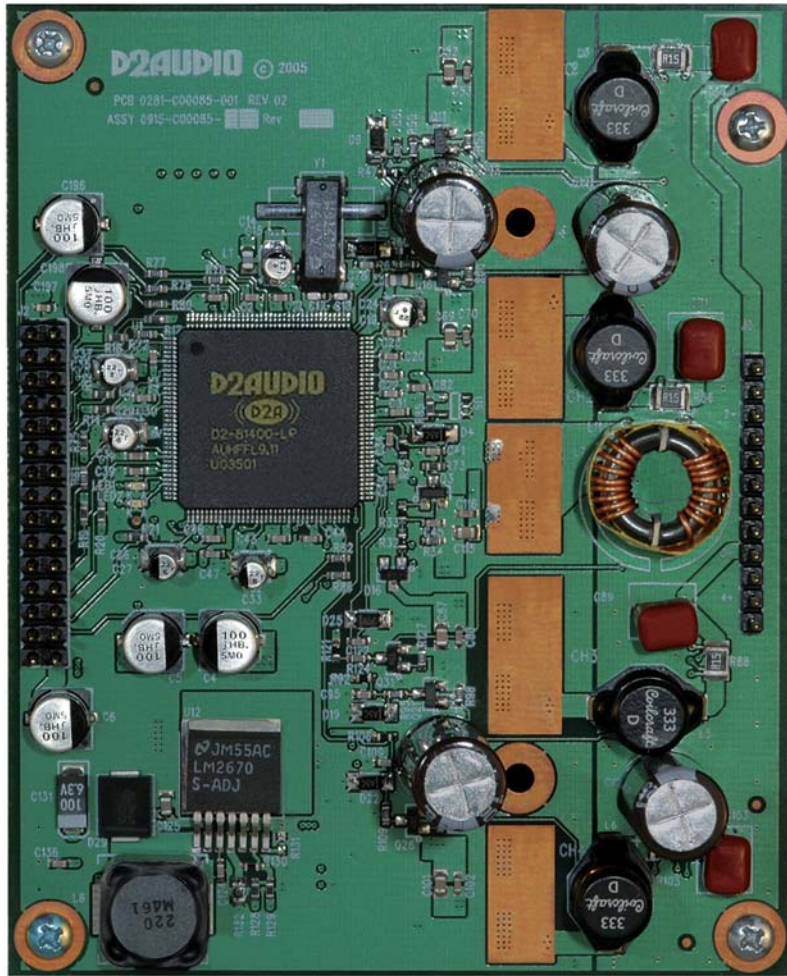

FIGURE 3. TXS25-4 AMPLIFIER BOARD - TOP VIEW

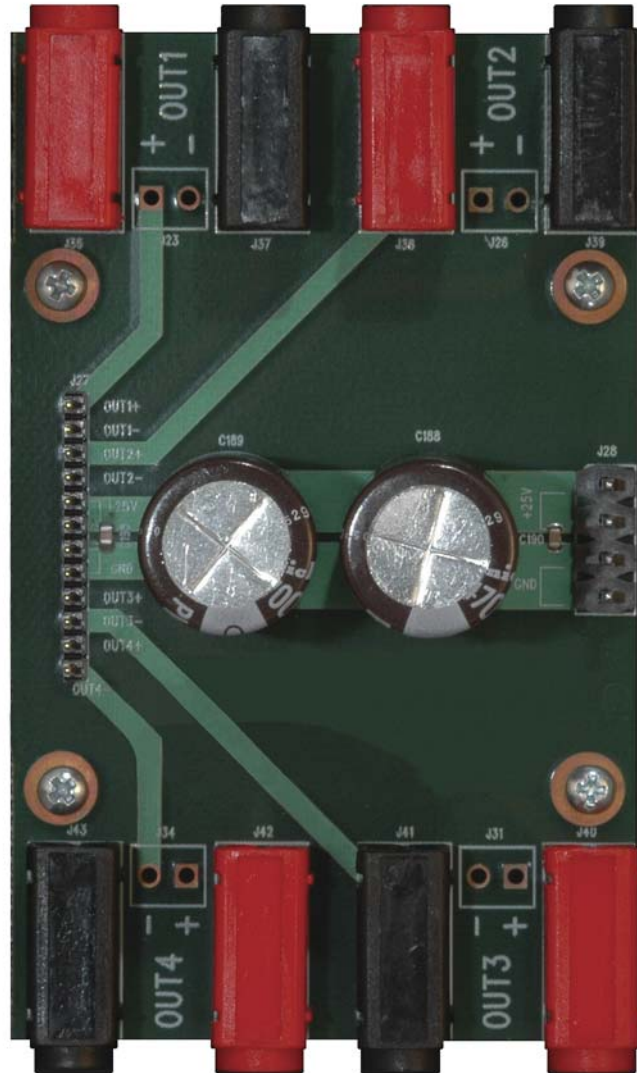

FIGURE 4. AMPLIFIER OUTPUT BOARD - TOP VIEW

Connection Diagram

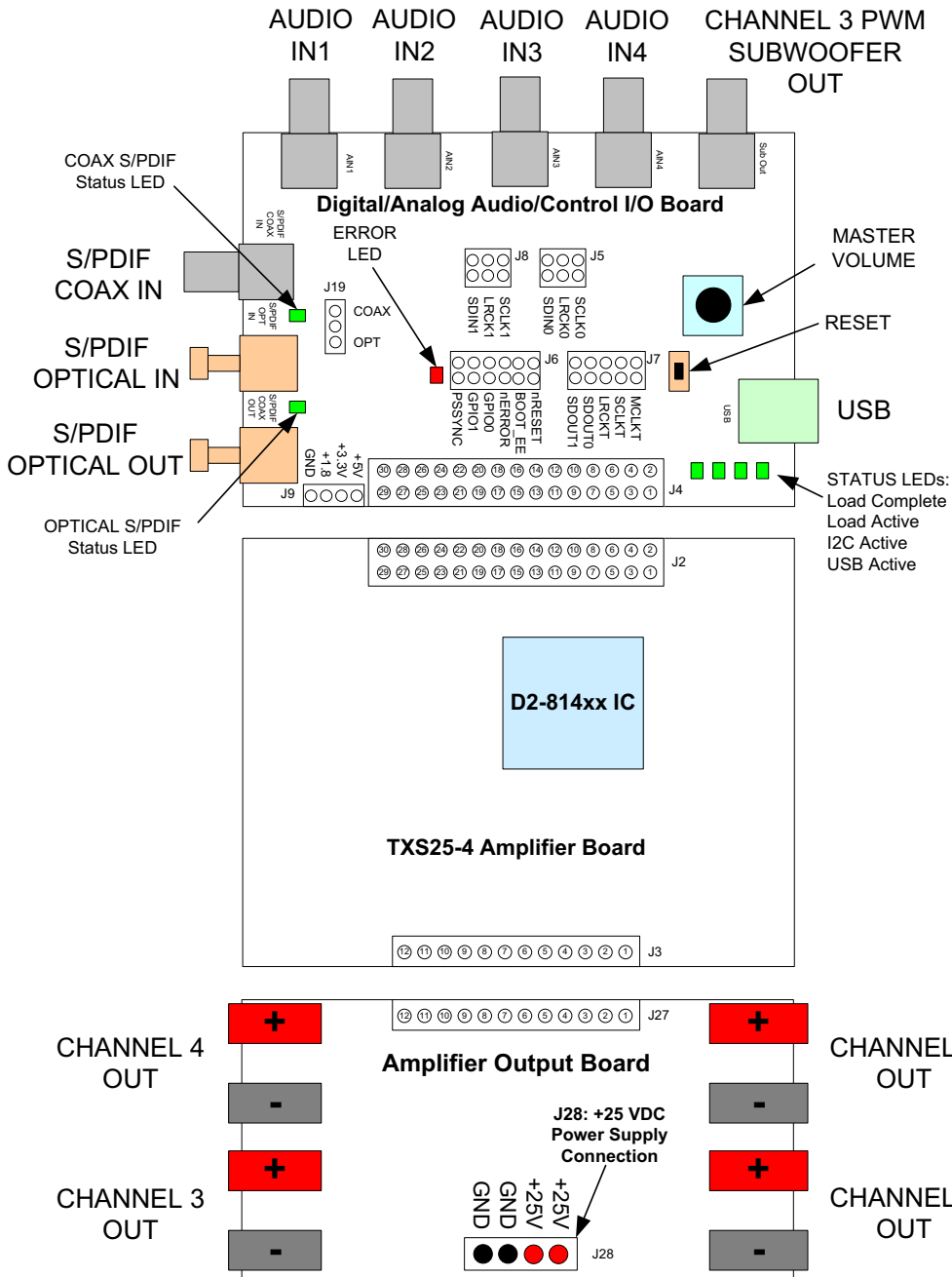

FIGURE 5. TXS25-4 AMPLIFIER PLATFORM CONNECTION AND JUMPER DIAGRAM

**Required Power Source**

The TXS25-4 Amplifier requires external operating power of a single DC power supply of 12V (minimum) up to 25V (maximum), with a minimum current sourcing capability of 5A. Maximum amplifier output power requires 25V, and maximum output power will be reduced as the DC supply voltage is also reduced. A well-filtered and regulated power supply is recommended. Supply voltage filtering, as well as input surge current limiting is provided on the amplifier output board where the power supply is connected. However amplifier noise performance may be impaired from power sources with excessive output ripple.

**Quick Start**

1. Set up in an ESD-approved work area.
2. Power supply must be OFF and power cord disconnected from AC outlet.
3. Observing correct polarity, connect DC output from a 25V, 5A power supply to connector J28 of the amplifier output board (Refer to “ Required Power Source” for J28 location and polarity.)
4. Ensure the supplied interconnect ribbon cables are connected between J4 of the Input Board and J2 of the TXS25-4 Amplifier board, and also between J3 of the TXS25-4 Amplifier Board and J27 of the Amplifier Output Board.
5. Select input source
  - Analog Audio Input . . . . . Figure 8
  - Optical S/PDIF . . . . . Figure 9
  - Coax S/PDIF . . . . . Figure 10

6. Connect Speakers
  - Output Device Connection (Stereo) . . . . . Figure 12
  - Output Device Connection (Channel System) Figure 13
7. Turn system on by switching on the DC power supply.
8. Play audio source. Adjust master volume for Channels 1 and 2 using the master volume knob.

**Speaker Channel Pair Matching and Drive Requirements**

Each of the TXS25-4 output channels are half-bridge, thus a load of equal size and content **MUST** be placed on corresponding channel pairs (e.g. Channel 1 and 2, Channel 3 and 4). This means that TXS25-4 is not meant to drive a 16Ω speaker on Channel 1 with an 8Ω speaker on Channel 2. This also means that if Channel 1 is high-pass filtered and connected to a tweeter, then Channel 2 must also be high-pass filtered and connected to a tweeter.

**Speaker Output Phase Relationship Requirements**

All TXS25-4 outputs are ground referenced. Channels 2 and 4 are driven intentionally out of phase with Channels 1 and 3. The audio heard on all 4-Channels will actually be in-phase, as Channels 2 and 4 are inverted inside the D2-814xx firmware. Please refer to Figure 5 for connection diagram. Speaker loads should also be connected or disconnected only when the power to the evaluation kit is turned off.

The user need only follow the standard connection method of RED terminal to the + lead and the BLACK terminal to the - lead of the speaker, as all of these inversions are already compensated within both the firmware and in the PCB trace connections.



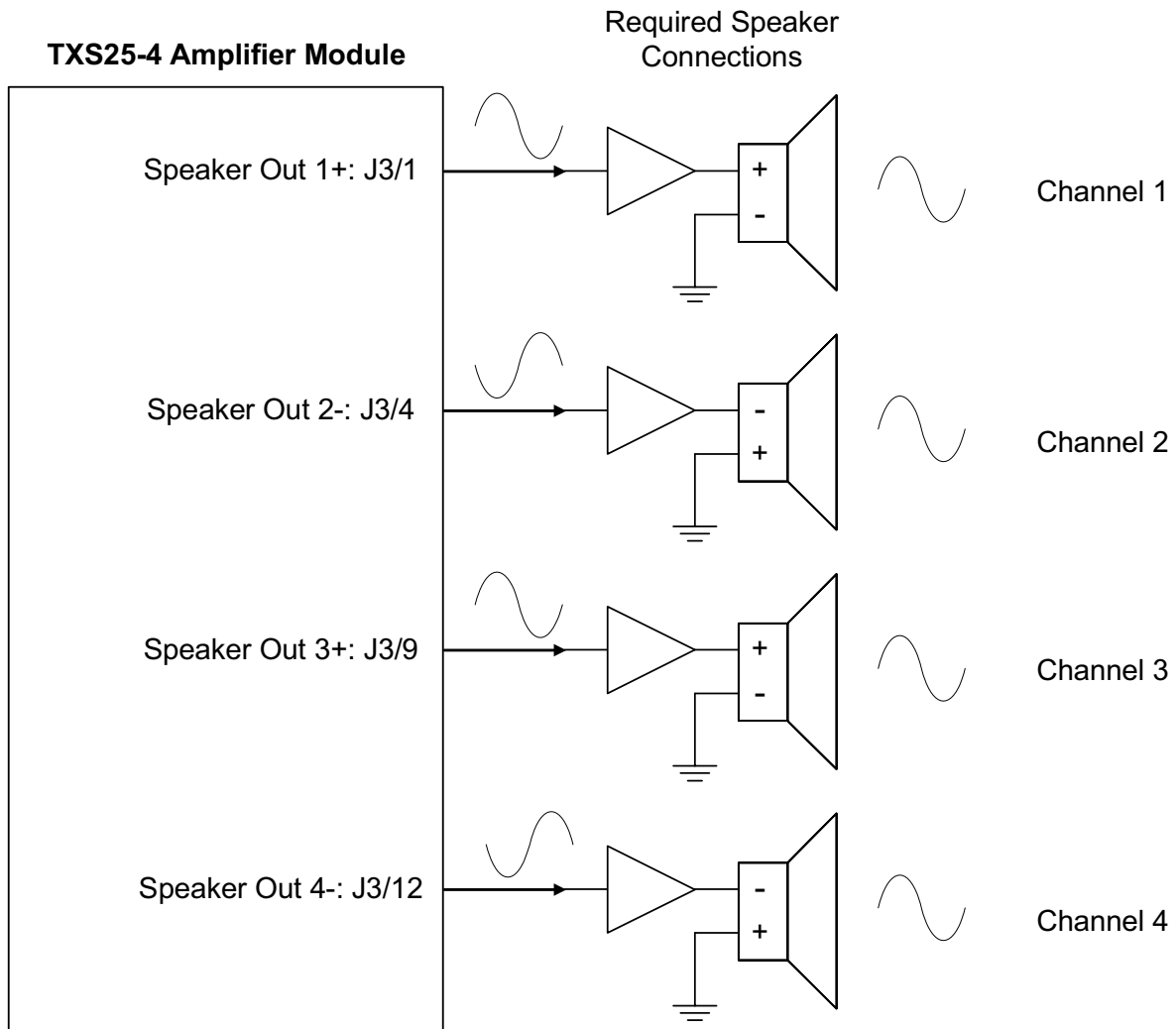

Note: Channels 2, 4 are 180 degrees out of phase vs. Channels 1, 3.  
 The above speaker connections are necessary to have all channels in phase.

FIGURE 6. REQUIRED LOUDSPEAKER CONNECTIONS

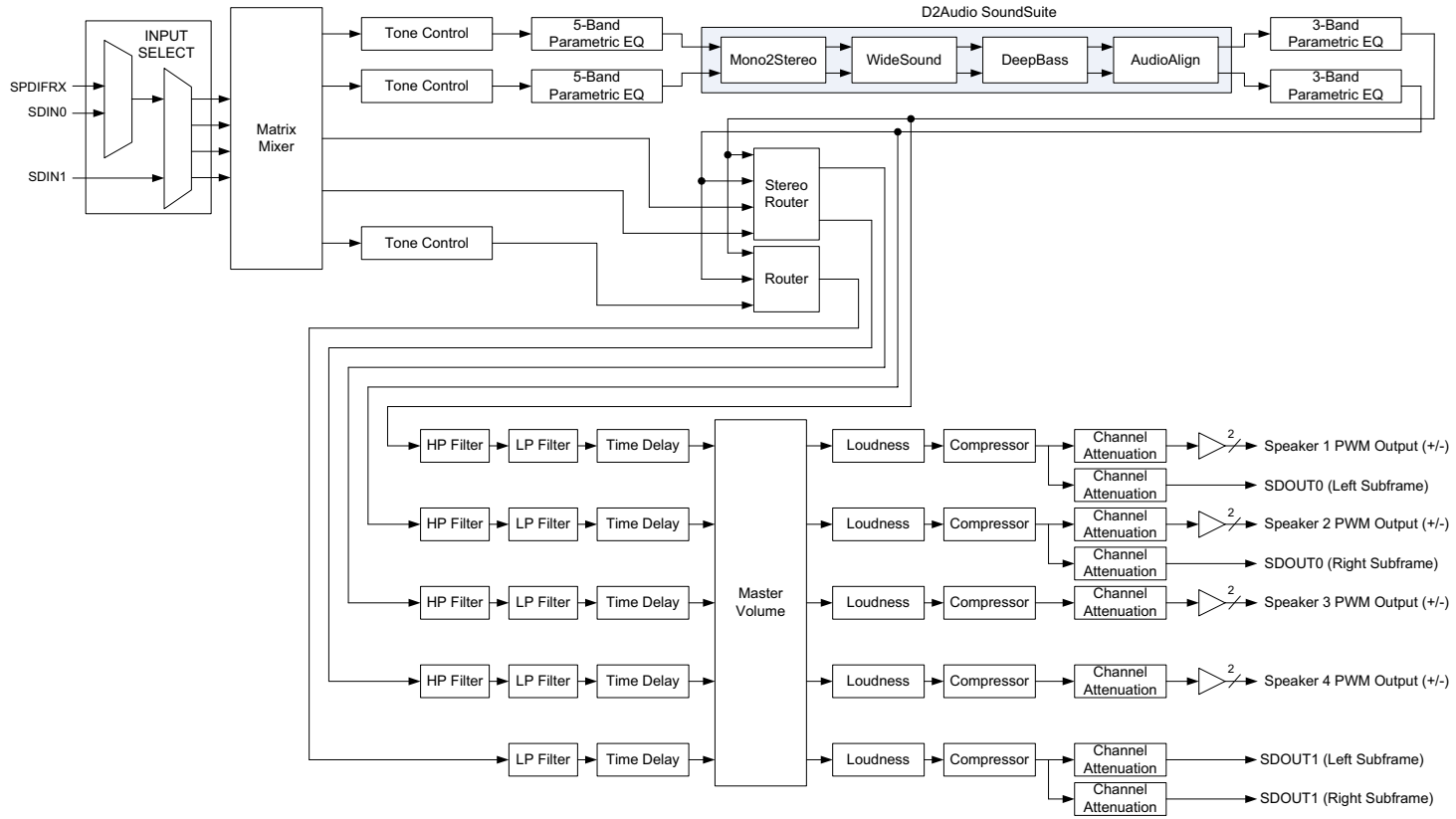

FIGURE 7. TXS25-4 SIGNAL FLOW DIAGRAM

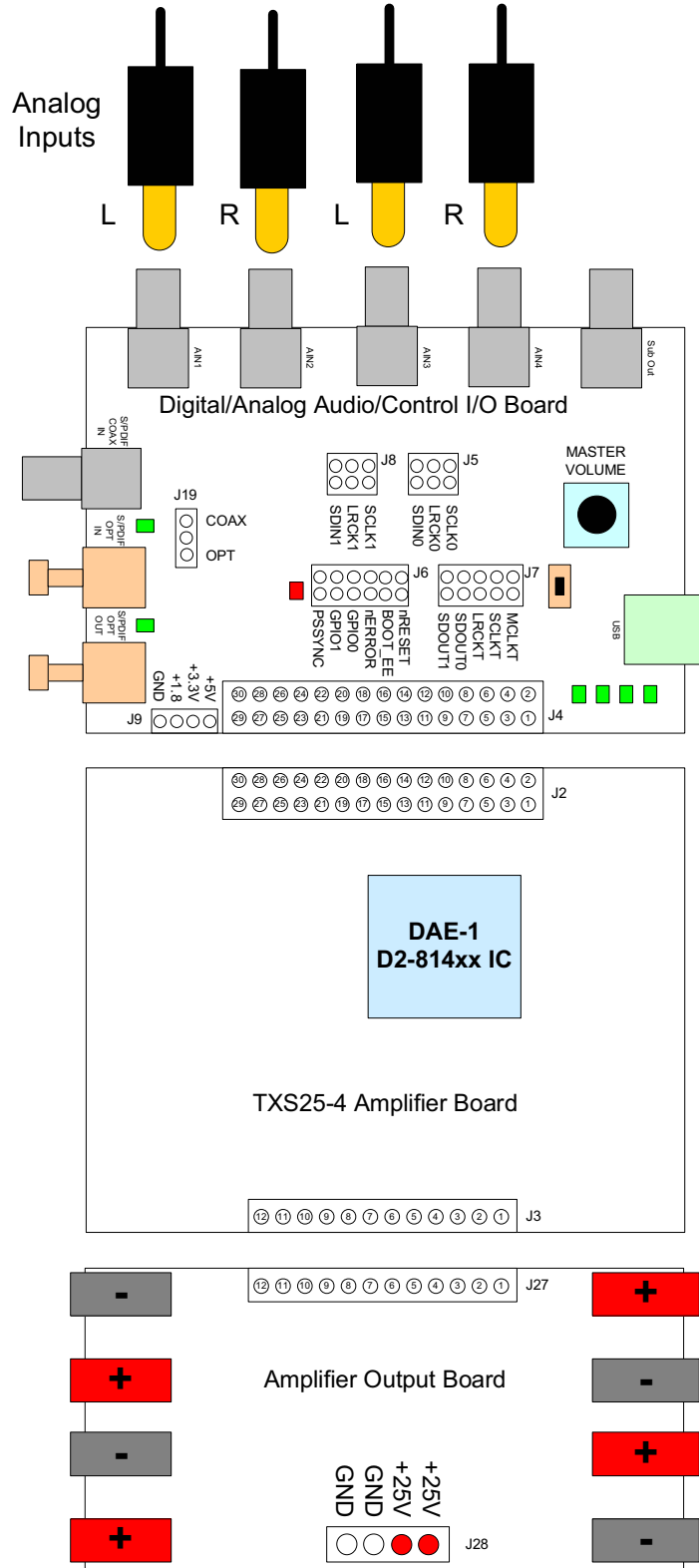

FIGURE 8. STEP 5: ANALOG INPUT

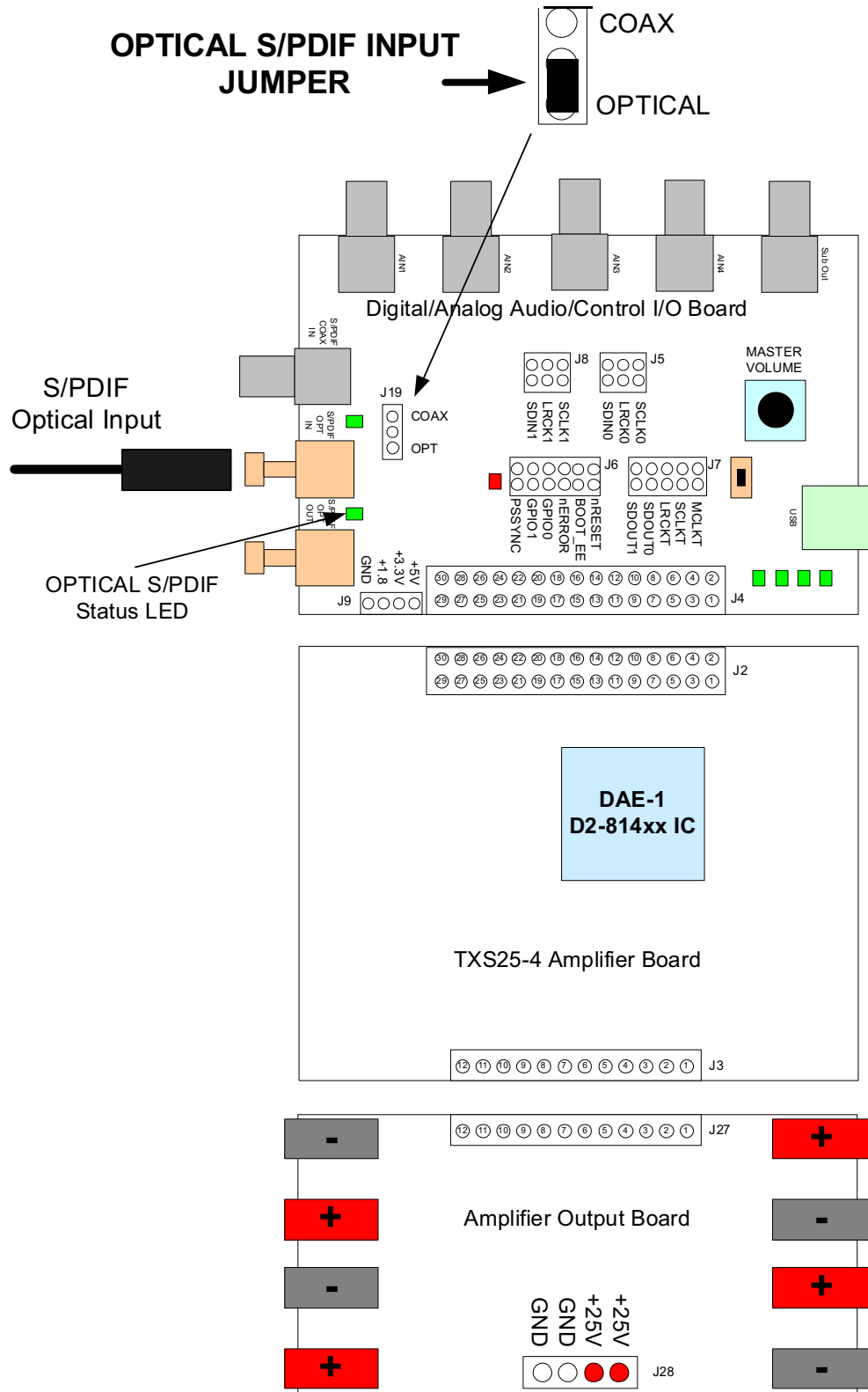

FIGURE 9. STEP 5: OPTICAL (TOSLINK) S/PDIF INPUT

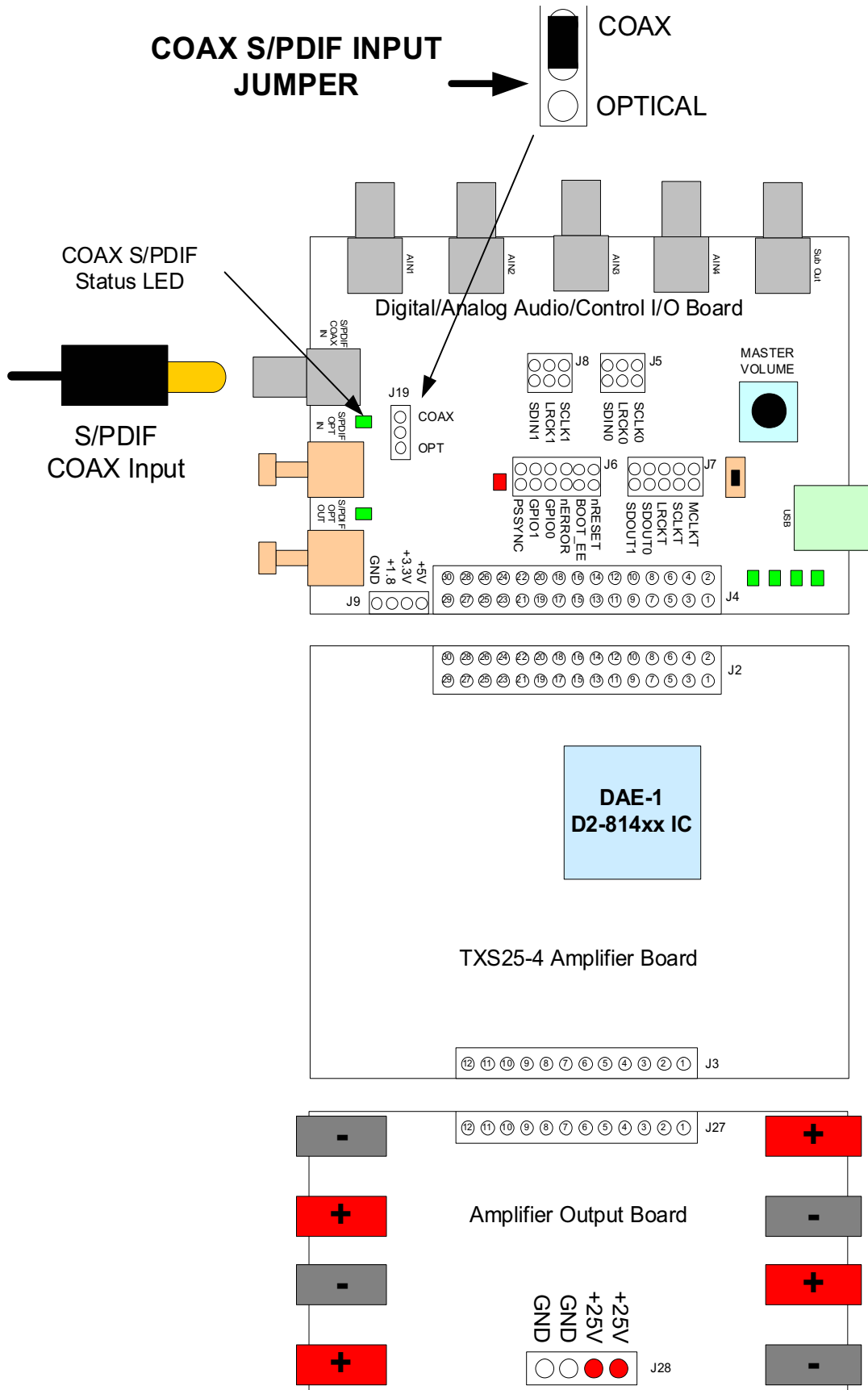

FIGURE 10. STEP 5: COAXIAL S/PDIF INPUT



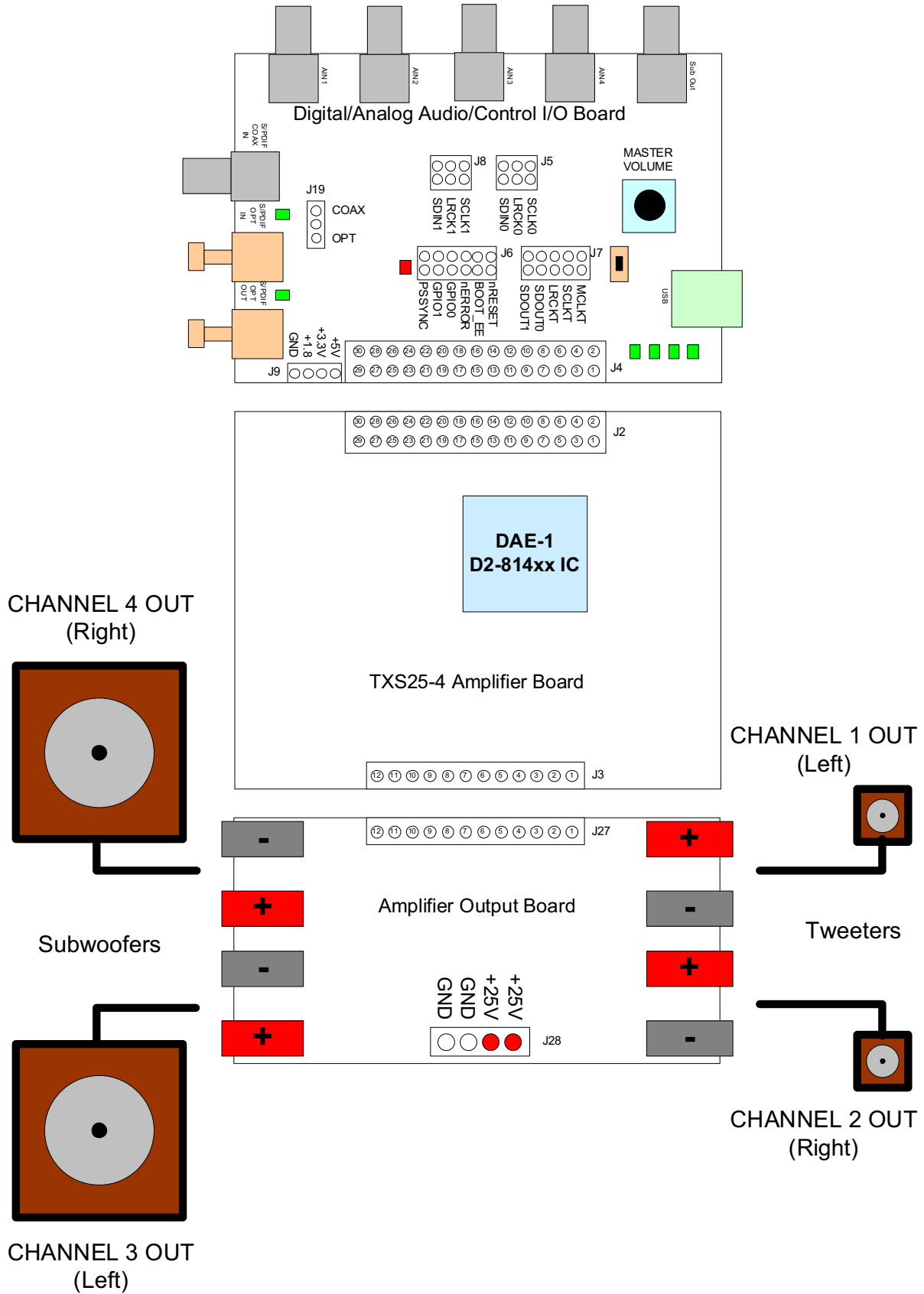

FIGURE 11. STEP 6: OUTPUT DEVICE CONNECTION FOR A STEREO/BI-AMP SYSTEM

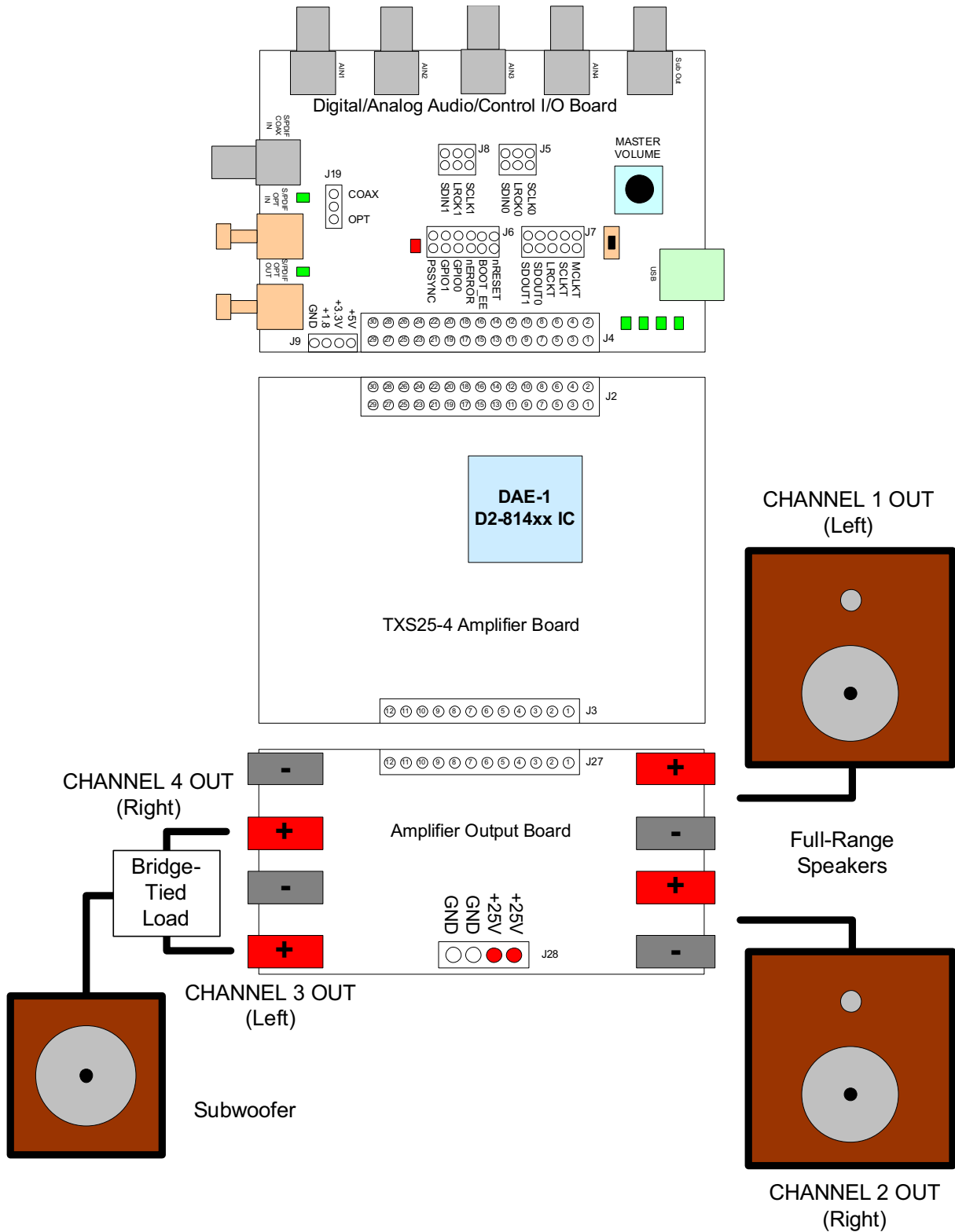

FIGURE 12. STEP 6: OUTPUT DEVICE CONNECTION FOR A 2.1 CHANNEL SYSTEM

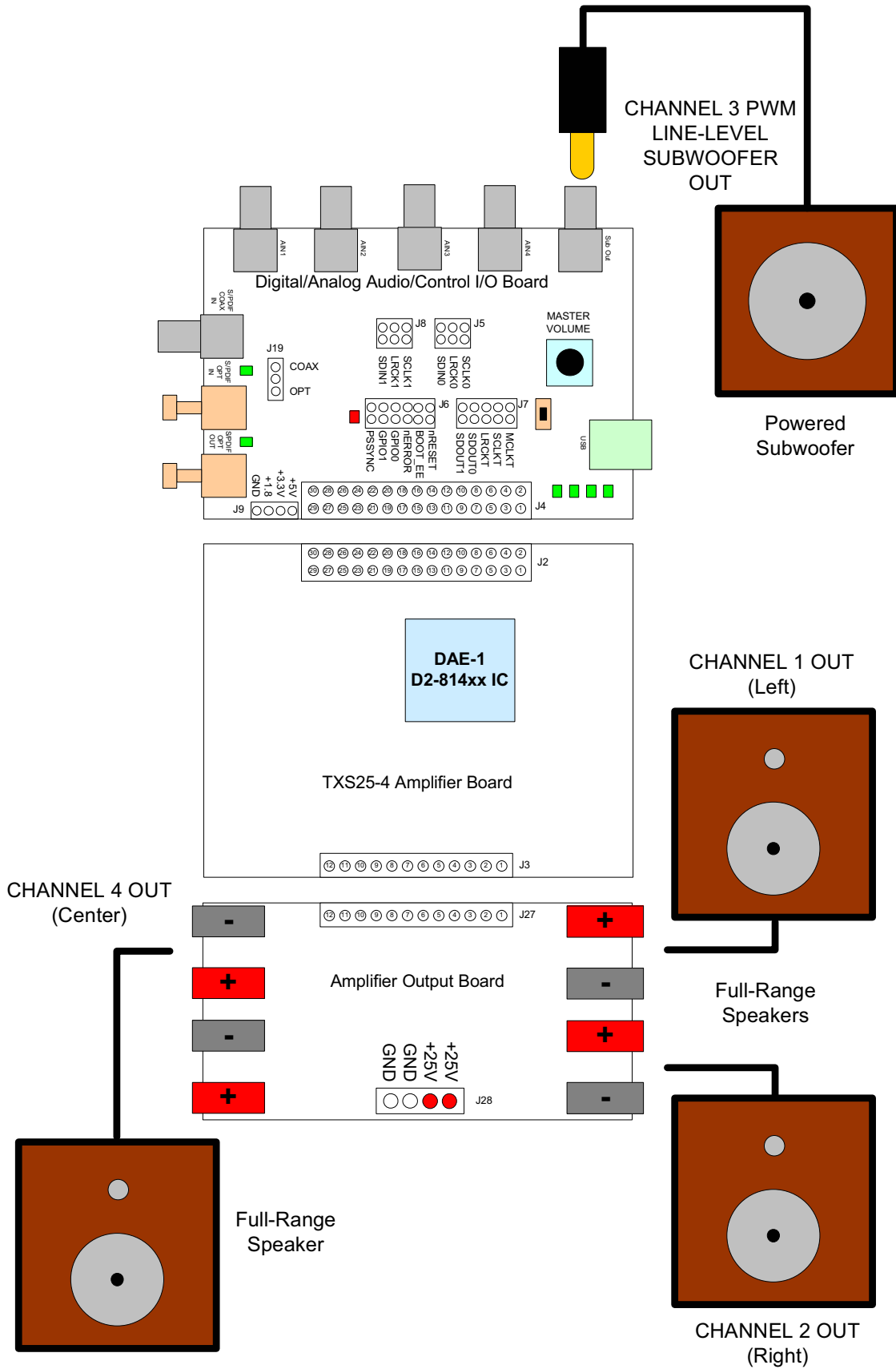

FIGURE 13. STEP 6: OUTPUT DEVICE CONNECTION FOR A 3.1 CHANNEL SYSTEM

**Input Source Options**

The TXS25-4 amplifier design contains 4 audio input channels. Several audio input source connections are available on the evaluation kit for these inputs.

**TABLE 1. EVALUATION KIT SOURCE OPTIONS**

INPUT CHANNEL	AVAILABLE DIGITAL SOURCE CONNECTIONS ON EVALUATION KIT	AVAILABLE ANALOG SOURCE CONNECTIONS ON EVALUATION KIT
Channels 1 thru 4	Coax S/PDIF receiver Optical S/PDIF receiver I <sup>2</sup> S/Left-Justified input headers	Direct connection to 4 Channel ADC, which is connected to the I <sup>2</sup> S/Left-Justified

**Selecting an Audio Input Type (S/PDIF, I<sup>2</sup>S/LJ or Analog)**

The default (which includes after a reset or power cycle) settings for the TXS25-4 firmware select the S/PDIF input. The selection of the audio input can only be changed using the Input Select Window inside the D2Audio Canvas II user interface GUI.

**Selecting Between I<sup>2</sup>S/Left-Justified Header Input and Analog Input**

In order to use the Analog Inputs, the user must select the “I<sup>2</sup>S” input. Additionally they must make sure that J18 is jumpered. By jumpering both the top and bottom J18 jumpers, both I<sup>2</sup>S streams from the 4 Channel ADC are sent to both the SAI0 input (labeled I2S0 on the board) and the SAI1 input (labeled I2S1 on the board). In order to use the I<sup>2</sup>S/Left-Justified input headers for both SAI0 and SAI1 input, the user must select the same “I<sup>2</sup>S” input in the D2Audio Canvas II menu in addition to making sure that J18 is NOT jumpered. Figure 14 shows how the board needs to be configured to route both I<sup>2</sup>S streams from the 4-Channel ADC to both the SAI0 input (labeled I2S0 on the board) and the SAI1 input (labeled I2S1 on the board). If the user wants to send I<sup>2</sup>S or Left-Justified data into the SAI0 or SAI1 input ports, they are free to “wire-wrap” into the input headers located at J5 and J8. If they choose to do this, they must remove both jumpers from J18.

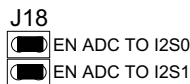
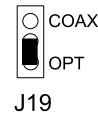

**FIGURE 14. ROUTING I<sup>2</sup>S DATA FROM THE 4-CHANNEL ADC TO THE SAI0 AND SAI1 INPUTS**

**Selecting Between Coaxial and Optical S/PDIF Input**

J19 can be jumpered between Coax and Opt during operation with out a need for a board reset in order to select Coaxial or Optical S/PDIF input. Figure 15 shows how to

select the Optical S/PDIF input. The user must still select the S/PDIF input mode.



**FIGURE 15. SELECTING BETWEEN COAXIAL AND OPTICAL S/PDIF INPUT**

When the S/PDIF input mode is selected (SPDIFRX), the COAX/OPT jumper (J19) determines which S/PDIF interface will be used.

**TABLE 2. J13 - S/PDIF INPUT SELECTION OPTIONS**

S/PDIF INPUT SELECTION	COAX	OPT
COAX/OPT	When S/PDIF input mode is enabled the Coax S/PDIF connector is selected	When S/PDIF input mode is enabled the Optical S/PDIF connector is selected

NOTE: These jumpers are not only read at power-up and after a reset to the amplifier design, but also during run time. Changes to the jumpers at any time will cause the settings to have an immediate effect and do not require a reset of the amplifier design to take effect.

**Default Configuration**

Table 3 highlights the SPDIF I/O board jumper configuration for the default factory setting for the TXS25-4 evaluation platform. NOTE: The jumpers are stored on the ground pins for this configuration. If N/A is listed in the Default Jumper Setting column then a jumper is not provided nor should the associated header ever be shorted.

**TABLE 3. DEFAULT DIGITAL/ANALOG AUDIO/CONTROL I/O BOARD FACTORY JUMPER SELECTION**

JUMPER NUMBER	DESCRIPTION	DEFAULT JUMPER SETTING	ADDITIONAL INFORMATION
	MCI Header	N/A	2-Wire Communication Header
J7	I <sup>2</sup> S/Left-Justified Output Header	N/A	Serial Audio Output 0, Serial Audio Output 1, associated LRCLKT, SCLKT, MCLKT. Connected to on board DAC
J5	I <sup>2</sup> S/Left-Justified Input Header	N/A	Serial Audio Input 0 (SAI0)
J8	I <sup>2</sup> S/Left-Justified Input Header	N/A	Serial Audio Input 1 (SAI1)
J6	Control Header	N/A	Refer to TXS25-4 Data Sheet for more information.
J19	SPDIF Input Select Header	Jumper pins 1 to 2	S/PDIF (SPDIFRX) Coax Input selected

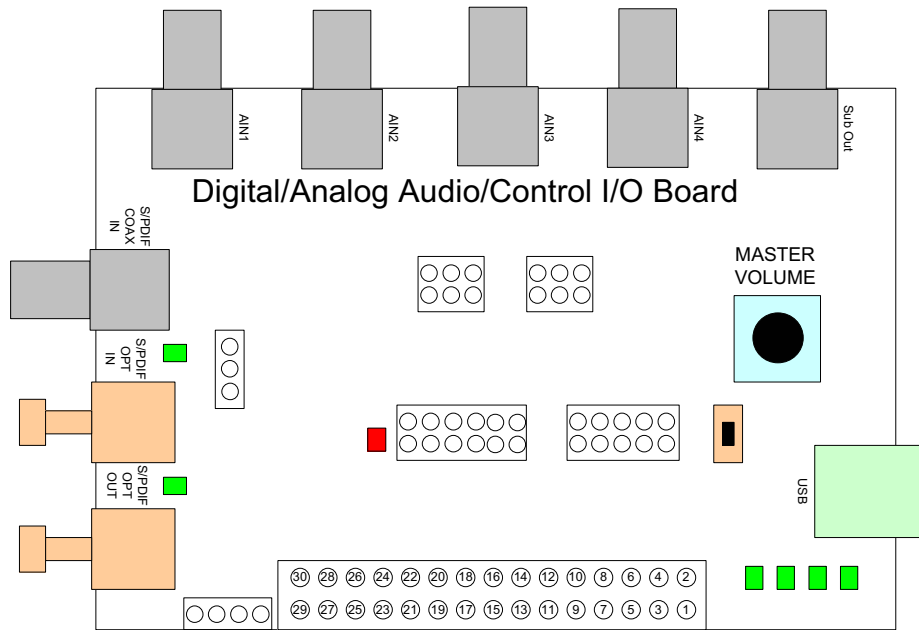

**FIGURE 16. MASTER VOLUME CONTROL KNOB**

### **Master Volume Control**

Each time the board is reset or powered up, the master volume will revert back to the default setting as stored in the EEPROM within the amplifier design. These settings can be saved to different levels by using D2Audio Canvas II software with the “Save Settings to EEPROM” command. When shipped from the factory, these value are -20dB. While the board is powered up, the master volume for only Channels 1 and 2 may be adjusted by turning the Master Volume Control knob located on the input board. Adjusting the Master Volume knob will adjust the Master Volume slider inside the D2Audio Canvas II GUI, provided that polling has been enabled within the D2Audio Canvas II program.



### Optional I<sup>2</sup>S/Left-Justified Connection

The TXS25-4 evaluation board may be connected to external I<sup>2</sup>S (or Left-Justified) audio sources. Three pins on jumpers J8 and J5 are available for I<sup>2</sup>S (or Left-Justified) connections (see Tables 4 and 5). The user must remove both jumpers on J18 in order to avoid clock and data contention from that being sent by the 4 channel ADC. The interface is a 3.3V signaling level with the I<sup>2</sup>S data format selected. Sample rates from 32kHz up to 192kHz are accepted. In addition, the TXS25-4 evaluation board is capable of driving up to 4-Channels of post-processed 24-bit PCM data on jumper J7 (see Table 6). MCLKT = 256Fs. SCLKT = 64Fs. LRCKT = Fs. Fs for data on SDOUT0 and SDOUT1 is fixed at 48kHz regardless of audio input Fs.

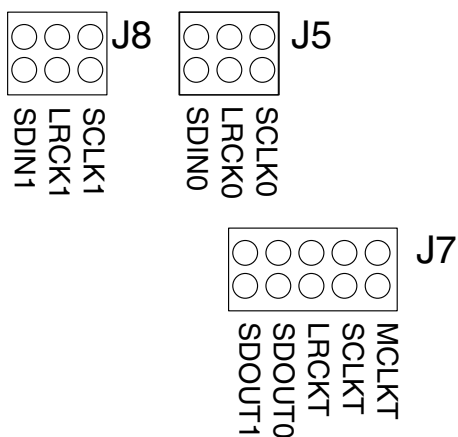

FIGURE 17. OPTIONAL I<sup>2</sup>S/LEFT-JUSTIFIED CONNECTIONS

TABLE 4. J5 - I<sup>2</sup>S/LEFT-JUSTIFIED (SAI0) INPUT HEADER PINS

SIGNAL	FUNCTION (I <sup>2</sup> S CHANNEL 0)
LRCLK0	3.3V Serial Audio Data Left/Right Frame Clock
SCLK0	3.3V Serial Audio Data Shift Clock
SDIN0	3.3V Serial Audio Data

TABLE 5. J8 - I<sup>2</sup>S/LEFT-JUSTIFIED (SAI1) INPUT HEADER PINS

SIGNAL	FUNCTION (I <sup>2</sup> S CHANNEL 1)
LRCLK1	3.3V Serial Audio Data Left/Right Frame Clock
SCLK1	3.3V Serial Audio Data Shift Clock
SDIN1	3.3V Serial Audio Data

TABLE 6. J7 - I<sup>2</sup>S/LEFT-JUSTIFIED (SAO0, SAO1) OUTPUT HEADER PINS

FUNCTION SELECTION	FUNCTION
SDOUT1	I <sup>2</sup> S Channel 1 - Serial Audio Data Output
SDOUT0	I <sup>2</sup> S Channel 0 - Serial Audio Data Output
LRCKT	I <sup>2</sup> S Serial Audio Data Left/Right Frame Clock Output
SCLKT	I <sup>2</sup> S Serial Audio Data Clock Output
MCLKT	I <sup>2</sup> S Master Clock Output

### Advanced Configuration with D2Audio Canvas II Software

All amplifier settings can be changed through the 2-wire control interface within the amplifier design. The D2Audio Canvas II software supplied with the evaluation kit provides a graphical interface and USB connection to a PC to adjust these settings on the evaluation kit. See the “D2Audio Canvas II Users Guide” for further details.

### Hardware vs Software Configuration

The D2Audio Canvas II software can be used to configure the TXS25-4 to select between I<sup>2</sup>S/Left-Justified inputs SAI0, which is connected to an ADC on this evaluation kit vs I<sup>2</sup>S/Left-Justified SAI1 which is available for designers to wire-wrap in an external digital audio device to the amplifier design. SAI0 and SPDIFRX can be accepted by the amplifier design simultaneously. The user is responsible for configuring the routing/mixing/processing of these two audio inputs using the D2Audio Canvas II GUI. With only 2 channels of audio physically connected to the board, this audio can be sent to all output channels using the Matrix Mixer and Routers, accessible through the D2Audio Canvas II software.

All settings, including master volume, are stored in an EEPROM within the amplifier design and are loaded upon reset or power-up. After power-up, the D2Audio Canvas II software can be used to change these settings and can update the EEPROM with a new set of defaults if desired. The only exception to this is the input selection settings which will always default back to the settings defined by the firmware.

Note the following:

Once the D2Audio Canvas II software is running, the Master Volume Control knob may still be used, however the Master Volume Control knob should not be adjusted when any D2Audio Canvas II hardware communication is taking place such as:

- Changing any D2Audio Canvas II controls including sliders, text fields, buttons, etc.
- Initial all-data transmit or receive performed during launch of D2Audio Canvas II and the associated “Connect to Module” process
- An all-data transmit or receive as triggered by the D2Audio Canvas II menu File->Transmit or File->Receive selections
- The D2Audio Canvas II menu Tools->Save Settings to EEPROM or Tools->Module Firmware Status selections

Alternatively, the designer can use the D2Audio Canvas II software to adjust the master volume, but just not at the same time as when the Master Volume Control knob is used.

### Testing Methodology

The following sections detail the testing methodology for obtaining optimal test results using an Audio Precision System Two.

### AES17 Filter Requirement

The test and measurement of a class-D audio amplifier requires additional considerations beyond that of a class-AB or class-A linear design. All Intersil amplifier products use noise-shaping techniques which provide extremely good noise and distortion performance within the audio band

(20Hz to 20kHz) in exchange for increased out-of-band noise (>20kHz). Each amplifier design contains a low-pass audio output filter, which attenuates this out-of-band noise present in the amplified signal.

Despite the presence of this filter, a small amount of out-of-band noise is still present in the amplifier output. When a standard 8Ω speaker is connected to the amplifier, this out-of-band noise has no effect on performance. However, the high-frequency nature of the out-of-band noise can exceed the maximum slew rate of the Audio Precision analog inputs, which can create erroneous measurements. In order to properly interface the Audio Precision test equipment to a class-D audio amplifier, the AES17 filter option must be installed and enabled. The response of the AES17 20kHz filter is shown in Figure 18.

It is important to note that the AES17 filter does not artificially improve the test results of a class-D amplifier to make them appear similar to those of a traditional class-AB or class-A amplifier. The filter is only present to reduce the high slew rate content of the amplifier output so that the Audio Precision may perform a proper test.<sup>1</sup>

1. For further information, see the white paper Measuring Switch-mode Power Amplifiers, by Bruce Hofer, Audio Precision, 2003, available at [www.audioprecision.com](http://www.audioprecision.com).

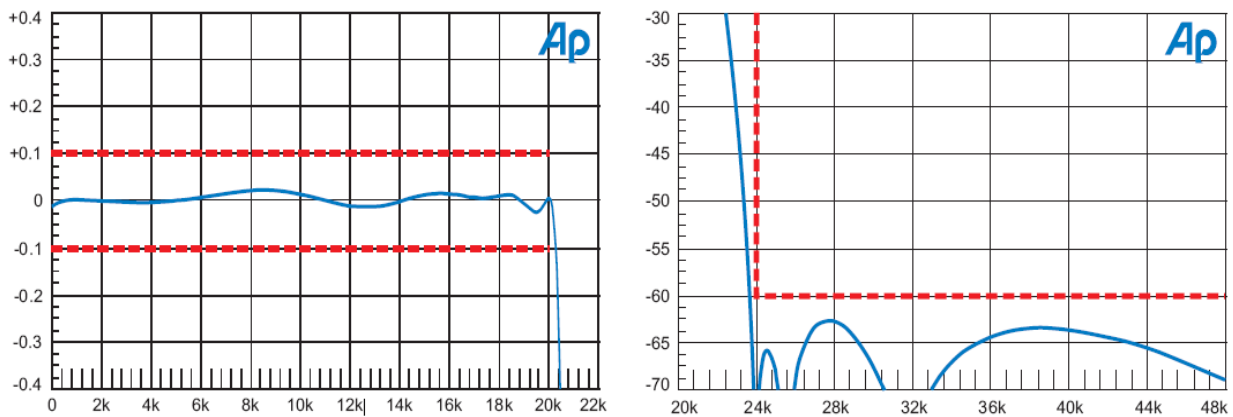

**FIGURE 18. AES17 FILTER PASSBAND AND STOPBAND RESPONSE, WITH 20KHZ SETTING**

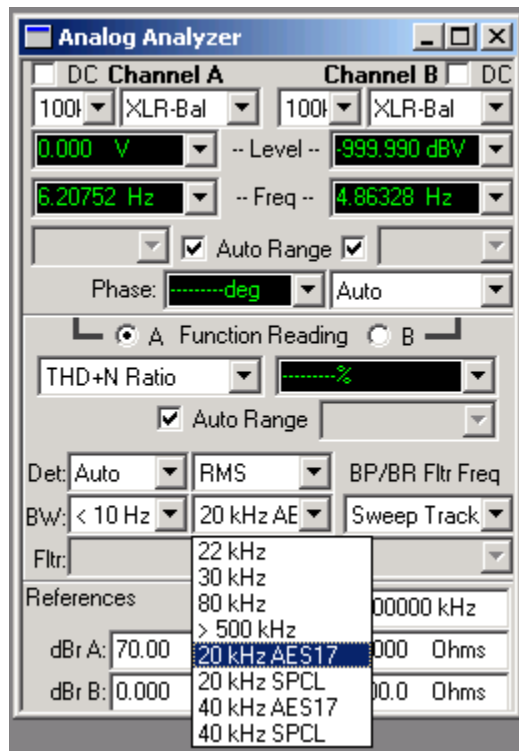

FIGURE 19. AUDIO PRECISION AES17 20KHZ FILTER SELECTION

**AUX-0025 Filter**

In addition to the AES17 filter, Audio Precision has an AUX-0025 filter product for measuring class-D amplifiers that either have no output filter, or an output filter with a limited rolloff. However, the AUX-0025 filter is NOT necessary when testing Intersil products, as all Intersil amplifier designs contain an output filter with steep low-pass rolloff.

**Testing Setup**

For proper amplifier characterization, the following conditions should be met:

- Measurements should be taken with only one amplifier channel driven.
- An 8Ω resistive load should be used on the output of the channel under test, with the Audio Precision input connected in parallel and set for high impedance (100kΩ). Tests should not be run on a channel without an 8Ω load connected.

The software settings in the amplifier design should be set for “flat” response with 0dB of gain. Verify each of the following settings before proceeding with a test: (Refer to the D2Audio Canvas II operation manual for setting “flat response”).

- The master volume of the amplifier must be set to 0dB.
- Each individual channel volume of the amplifier must be set to -6dB.
- All Equalizers, Tone Controls, Compression and Adjustable Time Delay should set to flat (0dB) or disabled.

Either analog or digital inputs may be used for testing. However, it is recommended that digital input sources (either I<sup>2</sup>S, Left-Justified or S/PDIF) be used for testing, as this will result in the most accurate measurement.

**TXS25-4 EVALUATION BOARD OUTPUT POWER NOTES**

The TXS25-4 is a reference and evaluation board, and therefore does not include heatsinking capability for extended high power use. Its heatsinking, simply through the copper pads on the pc board, was designed for a maximum of 1/8th continuous power on all channels in an open-air ambient of +25°C. Do not run high power sine waves continuously unless you have added additional heatsinking to the TXS25-4, as without additional heatsinking capability for output devices, generate excessive heat will be generated.

**TESTING WITH DIGITAL INPUTS (RECOMMENDED SETUP)**

All Intersil amplifier designs are digital by nature, and therefore will perform best when used with a digital input source. For proper test results, 24-bits of resolution or more are required. For this reason, a CD player cannot be used as a digital source, as it only provides 16-bit resolution.

When using the digital outputs of the Audio Precision, the following settings should be made:

- The TXS25-4 amplifier must be configured for the appropriate digital input (see “Input Source Options” on page 17)
- Data resolution should be 24 bits in the AP Digital Generator
- Pre-emphasis should be off in the AP Digital Generator
- Volts/FS reference should be set to 1V

Either S/PDIF or I<sup>2</sup>S/Left-Justified interfaces can be used. Specific settings for each interface are provided in the following:

**S/PDIF Source Setup**

In addition to the general digital configuration above, the following settings should be made in order to use the Audio Precision S/PDIF output:

- Either the optical or BNC electrical output can be used from the Audio Precision. Select the appropriate output in

the Digital I/O panel. Also select the appropriate position for the S/PDIF Input Select Jumper on the TXS25-4 board.

- Set the sample rate to 48kHz in the Digital I/O panel (though any values from 32kHz to 192kHz are acceptable).
- Set the output voltage to 5V<sub>p-p</sub> in the Digital I/O panel

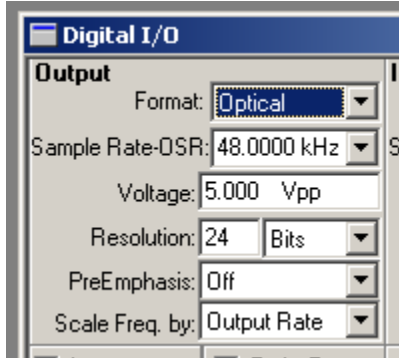

**FIGURE 20. AUDIO PRECISION S/PDIF OUTPUT CONFIGURATION**

### I<sup>2</sup>S Source Setup

The I<sup>2</sup>S/Left-Justified inputs on the TXS25-4 board can be connected to the output of an Audio Precision PSIA:

- Select the "PSIA" output in the Digital I/O panel.
- Select 3.3V CMOS as the output logic level in the PSIA Transmitter panel.
- Press the "I<sup>2</sup>S" button in the PSIA Transmitter panel to format the data for I<sup>2</sup>S.
- Press the "Outputs ON" button in the PSIA Transmitter panel to enable the PSIA output. Note that this button must be on in addition to the "Outputs ON" button in the Digital Generator panel in order for the PSIA output to function.

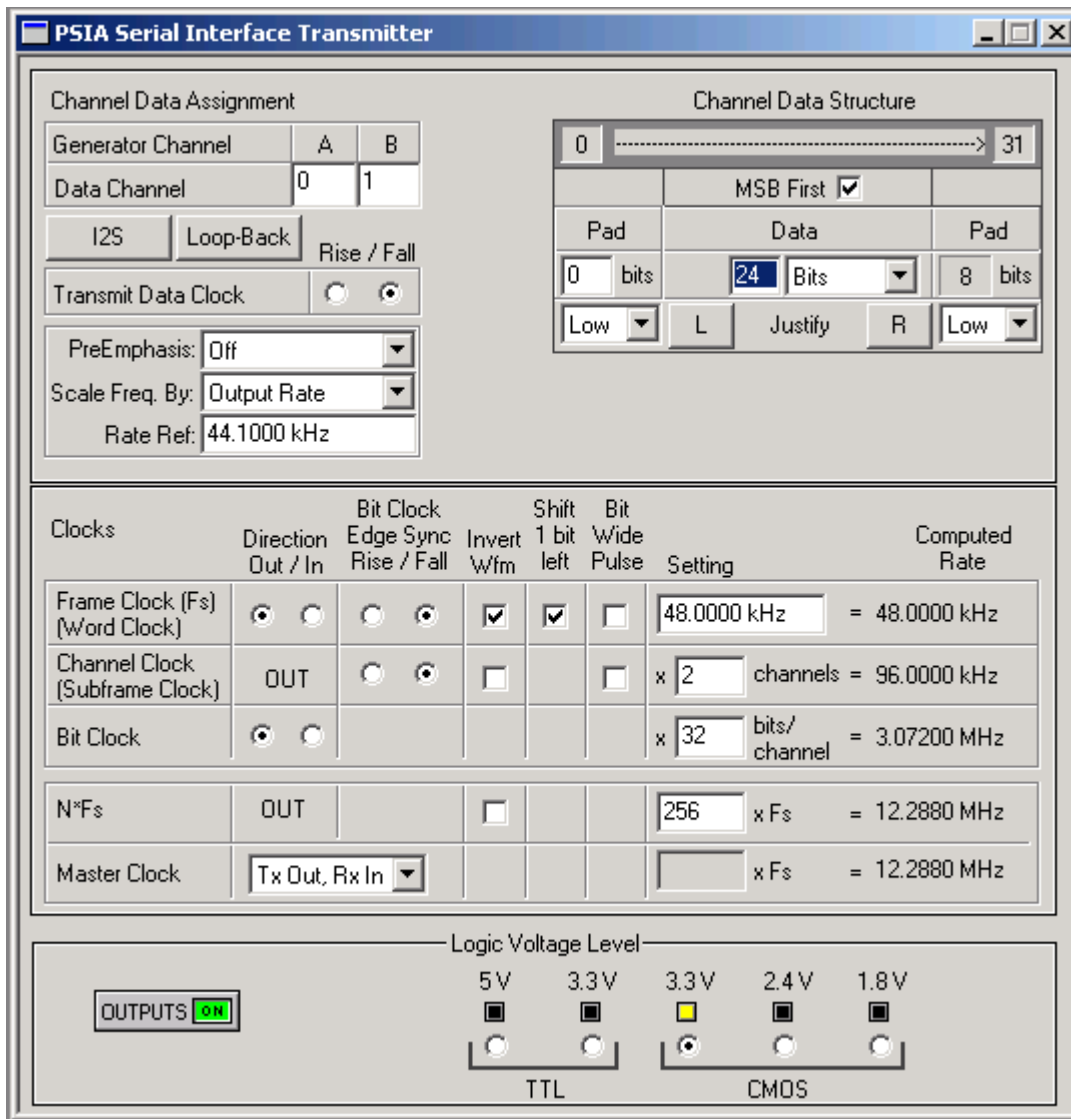

FIGURE 21. AUDIO PRECISION I<sup>2</sup>S OUTPUT CONFIGURATION

**TESTING WITH ANALOG INPUTS**

Analog-to-digital converters are present on the TXS25-4 amplifier design. These can provide a secondary input source to the amplifier design. However, it is suggested that digital inputs be used for testing if at all possible, since analog input performance will be slightly less than that measured with the digital input.

When using the analog outputs of the Audio Precision, the following settings should be made:

- The dBr Reference Voltage should be set to 2V in the Analog Generator Panel if using the analog inputs of the amplifier design.
- The dBr Reference Voltage should be set to 1V in the Analog Generator Panel if using the external high-performance ADCs.
- The Watts reference should be set to 8Ω in the Analog Generator Panel
- Z-Out should be set to 20Ω in the Analog Generator Panel.
- Configuration should be set for Unbal-Float in the Analog Generator Panel. Unbal-GND may yield better results.



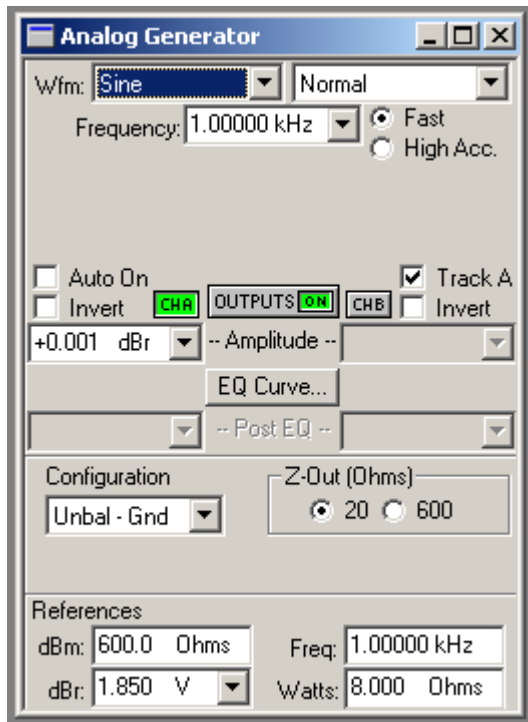

FIGURE 22. AUDIO PRECISION ANALOG OUTPUT CONFIGURATION

**Typical Basic Measurements**

The following measurements in Table 7 can be made by using the Analog Analyzer panels in the Audio Precision software. The measurements in Table 8 were made using a digital input source.

TABLE 7. TXS25-4 BASIC MEASUREMENTS, RATED POWER, 8Ω LOAD (-0.5DBFS INPUT)

MEASUREMENT DESCRIPTION	TYPICAL RESULT	UNITS
Output voltage on speaker terminals	31	V <sub>RMS</sub>
Total Harmonic Distortion + Noise Percentage (THD+N) 20Hz to 20kHz	<0.2	%
Signal to Noise+Distortion Ratio (Total Harmonic Distortion + Noise Amplitude relative to full scale output (31V <sub>RMS</sub> ))	>-105	dBr

NOTE:

1. These results are preliminary, based on Rev 1 of the TXS25-4 Evaluation Kit.

TABLE 8. TXS25-4 BASIC MEASUREMENTS, 1W POWER, 8Ω LOAD (-21DBFS INPUT) @ 1kHz

MEASUREMENT DESCRIPTION	TYPICAL RESULT	UNITS
Output voltage on speaker terminals	2.8	V <sub>RMS</sub>
Total Harmonic Distortion + Noise Percentage (THD+N) 20Hz to 20kHz	<.05	%

NOTE:

2. These results are preliminary, based on Rev 1 of the TXS25-4 Evaluation Kit.

**TXS25-4 Evaluation Platform Hardware**

**Power Supplies**

The TXS25-4 amplifier design operates from a single +25V, 5A DC power supply. This external power supply connects to header J28 of the amplifier output board, where DC power filtering is also provided. All other operating voltages are internally generated from this 25V source. The TXS25-4 amplifier board internally generates -25V for the FETs. (This is a half-bridge design.) The first switching stage takes the +25V primary input supply voltage and generates the required -25V, under the control of the D2-814xx IC. The +25V is also sent to a DC/DC circuit which regulates down to +5V; the second stage regulates +5V down to +3.3V and +1.8V for the control input functions using parallel linear regulators. The low voltage regulation provides proper power sequencing in addition to low power dissipation (high efficiency).

**Remote Input Board**

The TXS25-4 evaluation PCB allows the Digital/Analog Audio/Control I/O Board and Amplifier Output sections of the board to be separated from the TXS25-4 amplifier board. The ribbon cables may be extended by replacing the provided ribbon cables. This allows the Digital/Analog Audio/Control I/O Board section to be mounted remotely from the TXS25-4 and output boards as well as allowing for easier design-in for prototyping. Extension of the ribbon cable may result in degradation of the digital audio input signal (I<sup>2</sup>S/LJ (from headers or 4-Channel ADC) or S/PDIF) signal integrity. Extension should be limited to six inches or less.

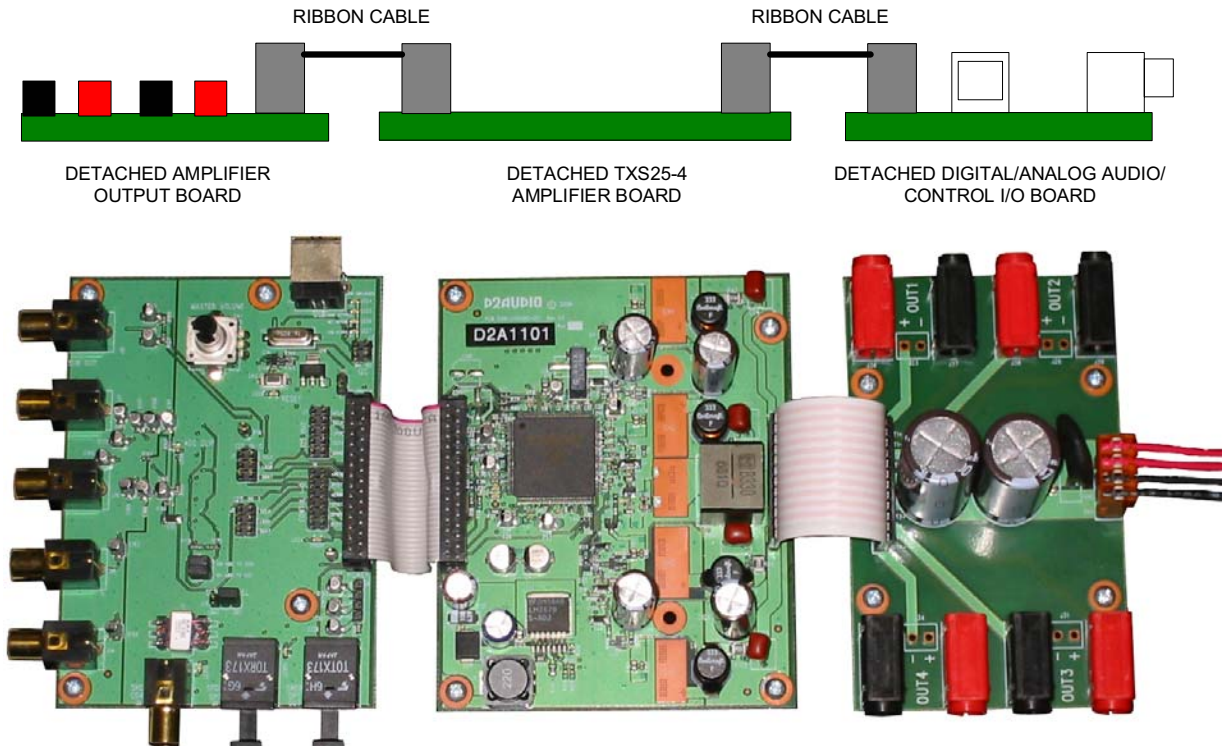

FIGURE 23. DIGITAL/ANALOG AUDIO/CONTROL I/O BOARD, AMPLIFIER BOARD, AND OUTPUT BOARD

### USB Interface

A USB interface is provided on the TXS25-4 evaluation platform to provide communications between the TXS25-4 amplifier design and an external PC based system. The USB interface provides a means of upgrading the amplifier design system parameters, input sources, and DSP firmware. The D2Audio Canvas II utility provided with the TXS25-4 evaluation platform utilizes this interface. Refer to the D2Audio Canvas II Users Guide for USB driver installation and instructions.

# Hardware Schematics

## Block Diagram

OPTIONAL



DSP, Input Header & V-Regs

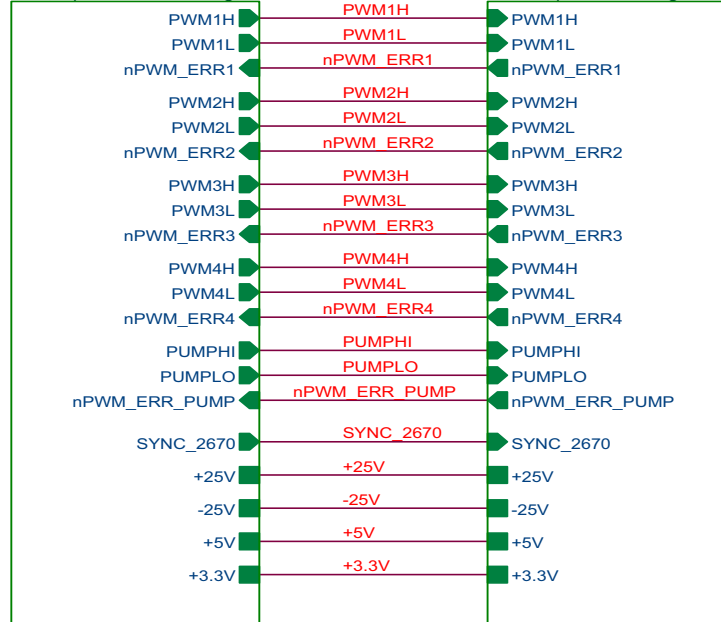

Output Power Stages

OPTIONAL

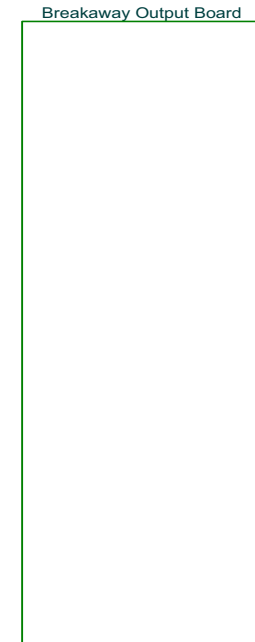

This schematic contains sections for both the TXS 25-4 AMPLIFIER DESIGN and it's evaluation components.

The design of the amplifier and evaluation kit includes a single PCB that can be broken into 3 pieces: Input, Amplifier, Output & Power Supply Connections.

Schematic Page

1 Overview

2-5

Core Amplifier (some sections may be marked optional)

6-10

Optional for Eval Kit

# Hardware Schematics (Continued)

## Reference Schematic

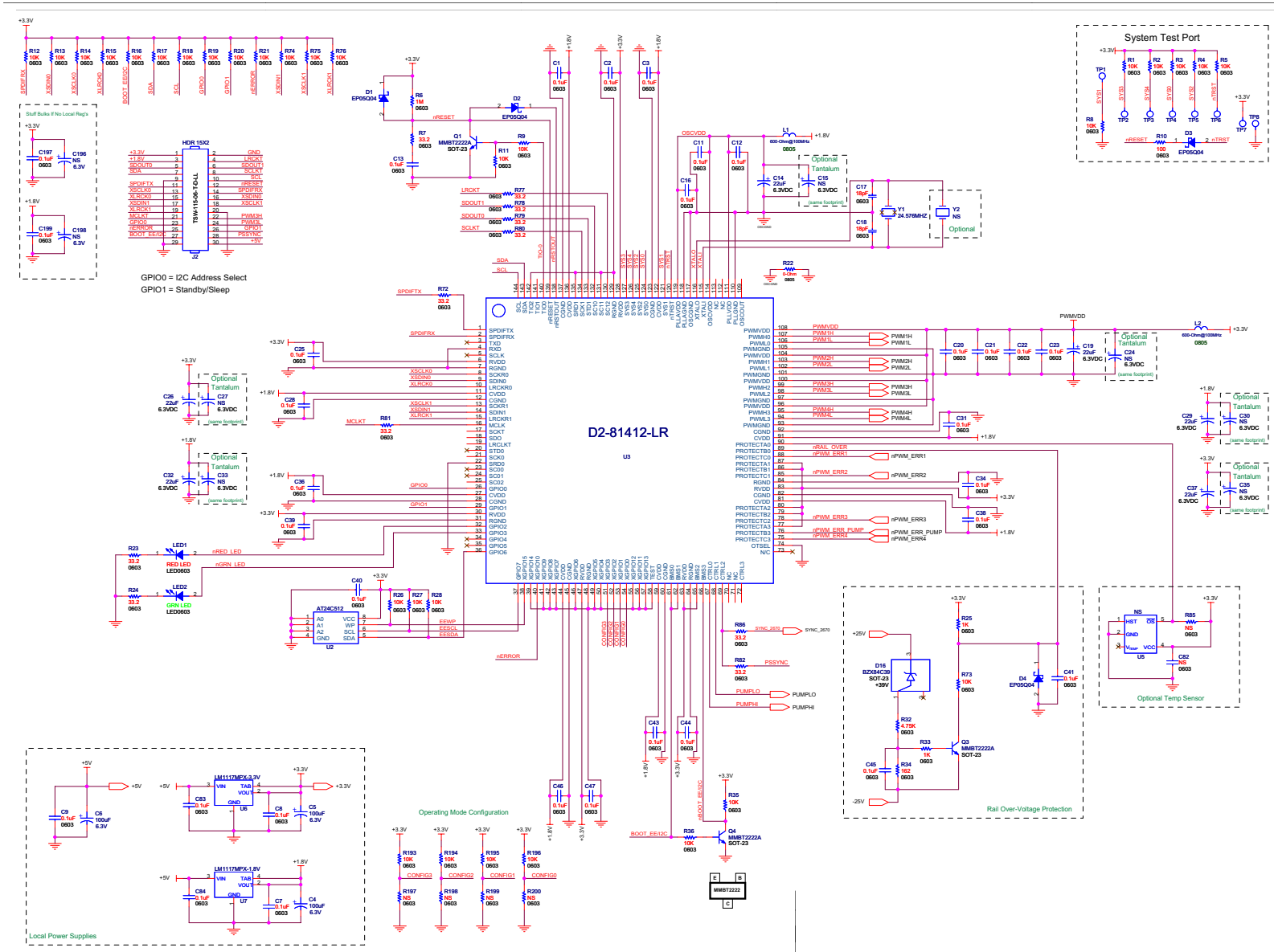

Application Note 1435



# Hardware Schematics (Continued)

## Power Stages 3-4

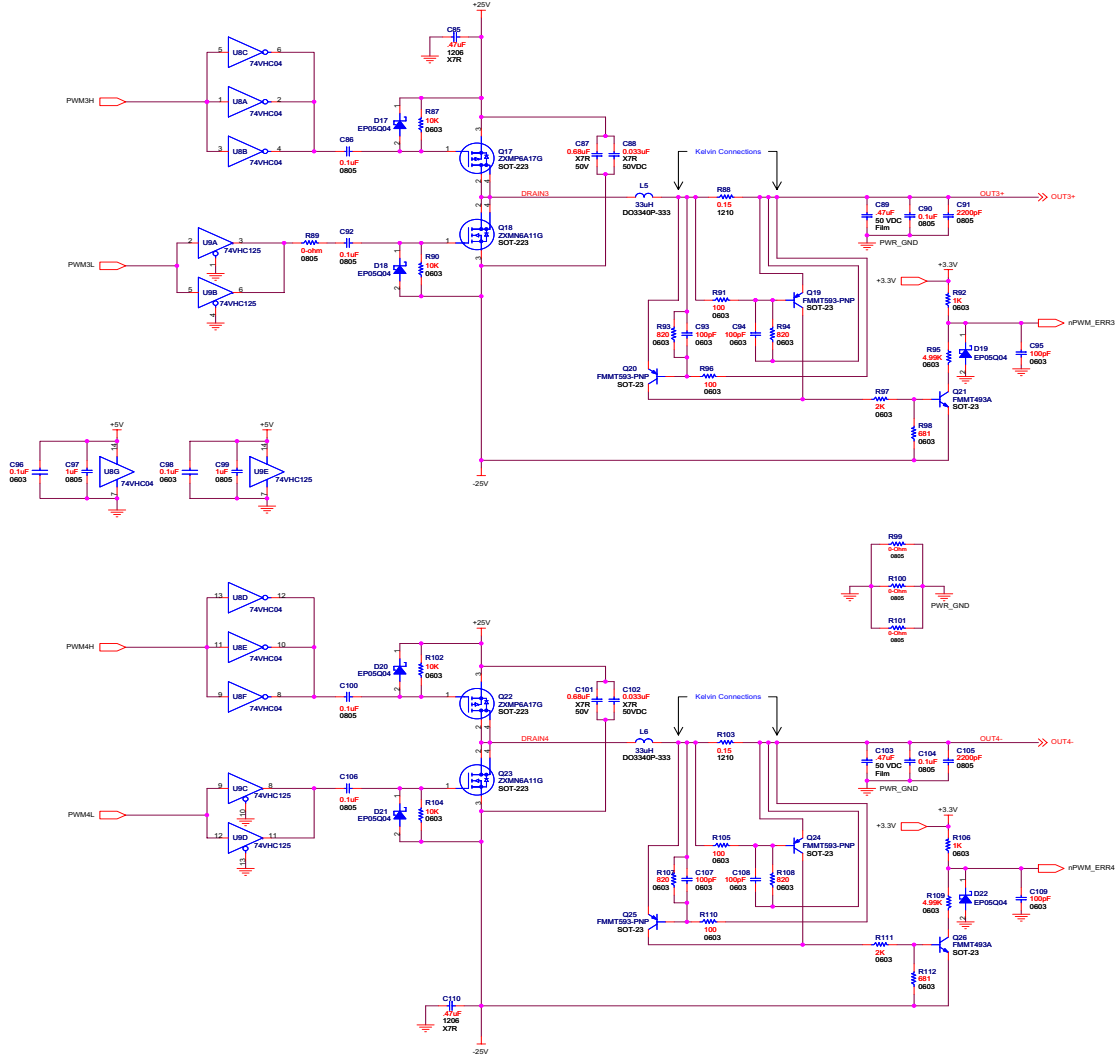

# Hardware Schematics (Continued)

## Pump, Output Header, +5V SMPS

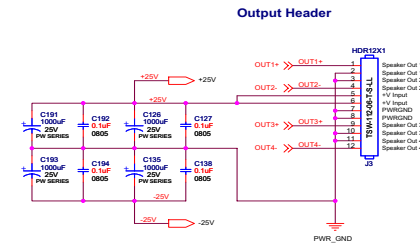
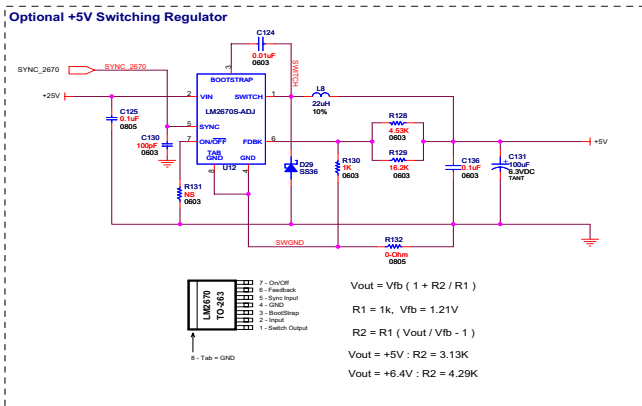
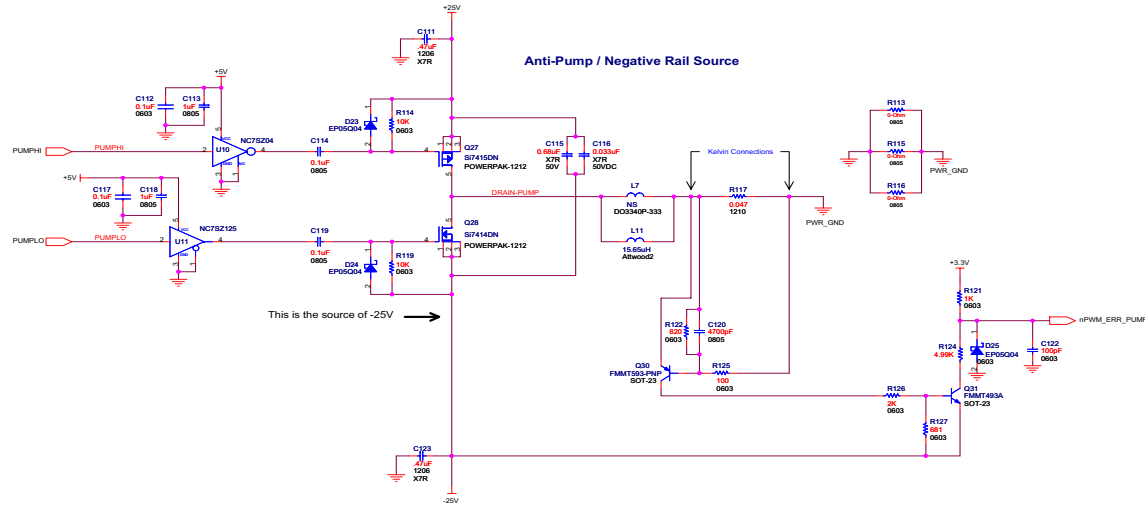
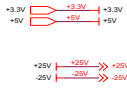

# Hardware Schematics (Continued)

## Breakway - Headers and Sub-Out

**Interconnect Header**

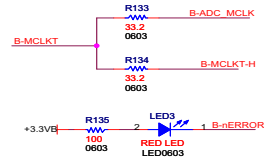
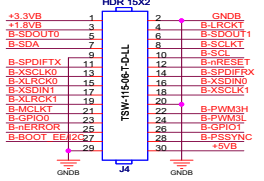

**Ground Loop Test Points**



**Misc Signal Header**

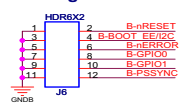

**I2S Input Headers**

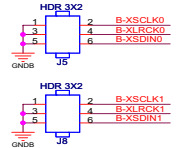

**I2S Output Header**

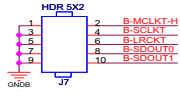

**Power Header**

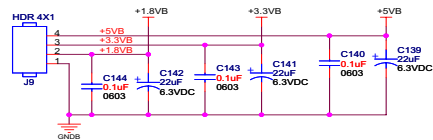

**Subwoofer Low Pass Filter and Output Jack**

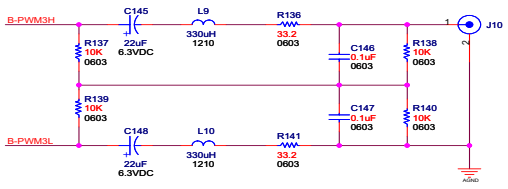

**Global Power Rails**



**To/From USB & Reset Page**



**To/From ADC Page**

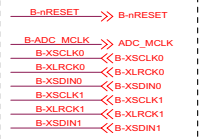

**To/From SPDIF Page**

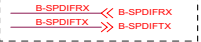



# Hardware Schematics (Continued)

## Breakway - USB and Reset

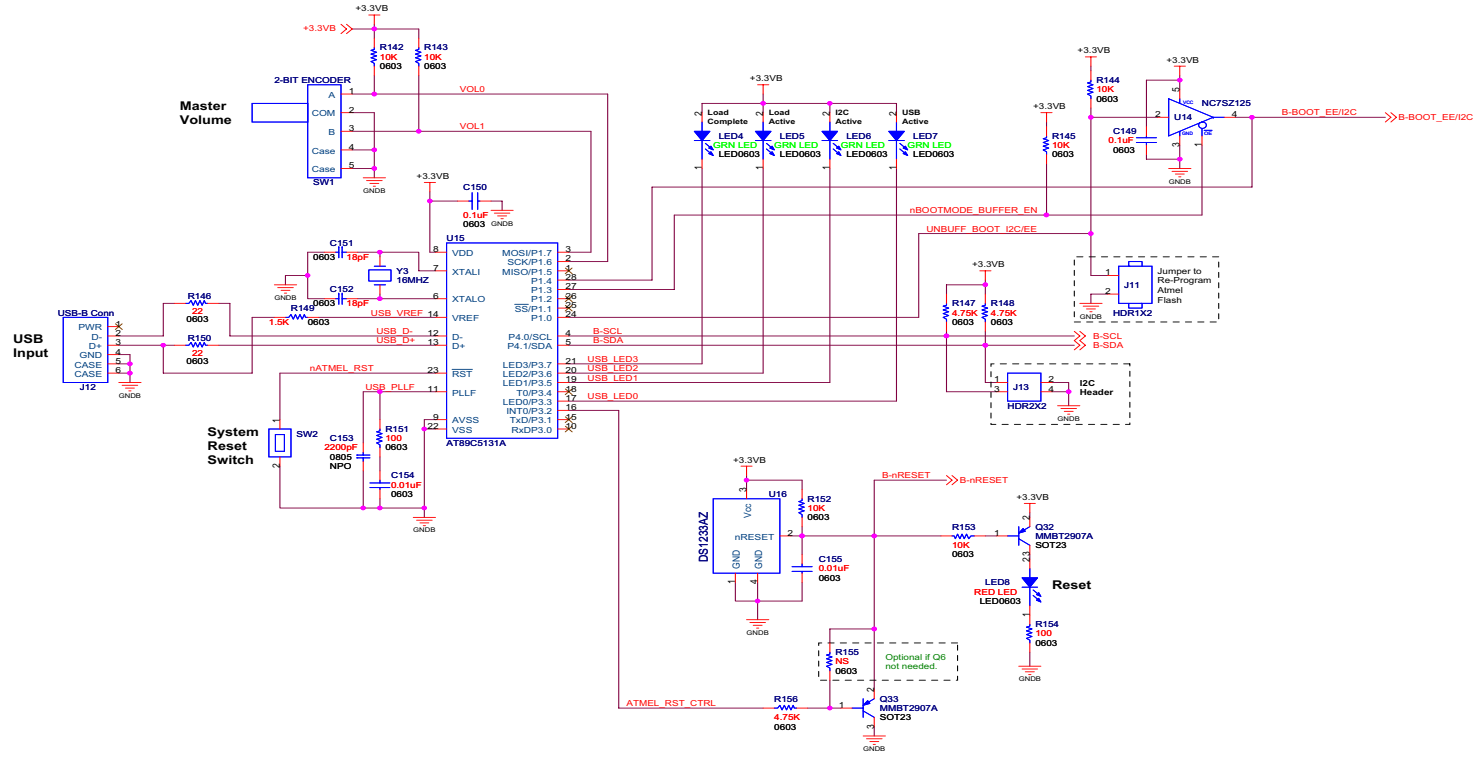

# Hardware Schematics (Continued)

## Breakway - ADC

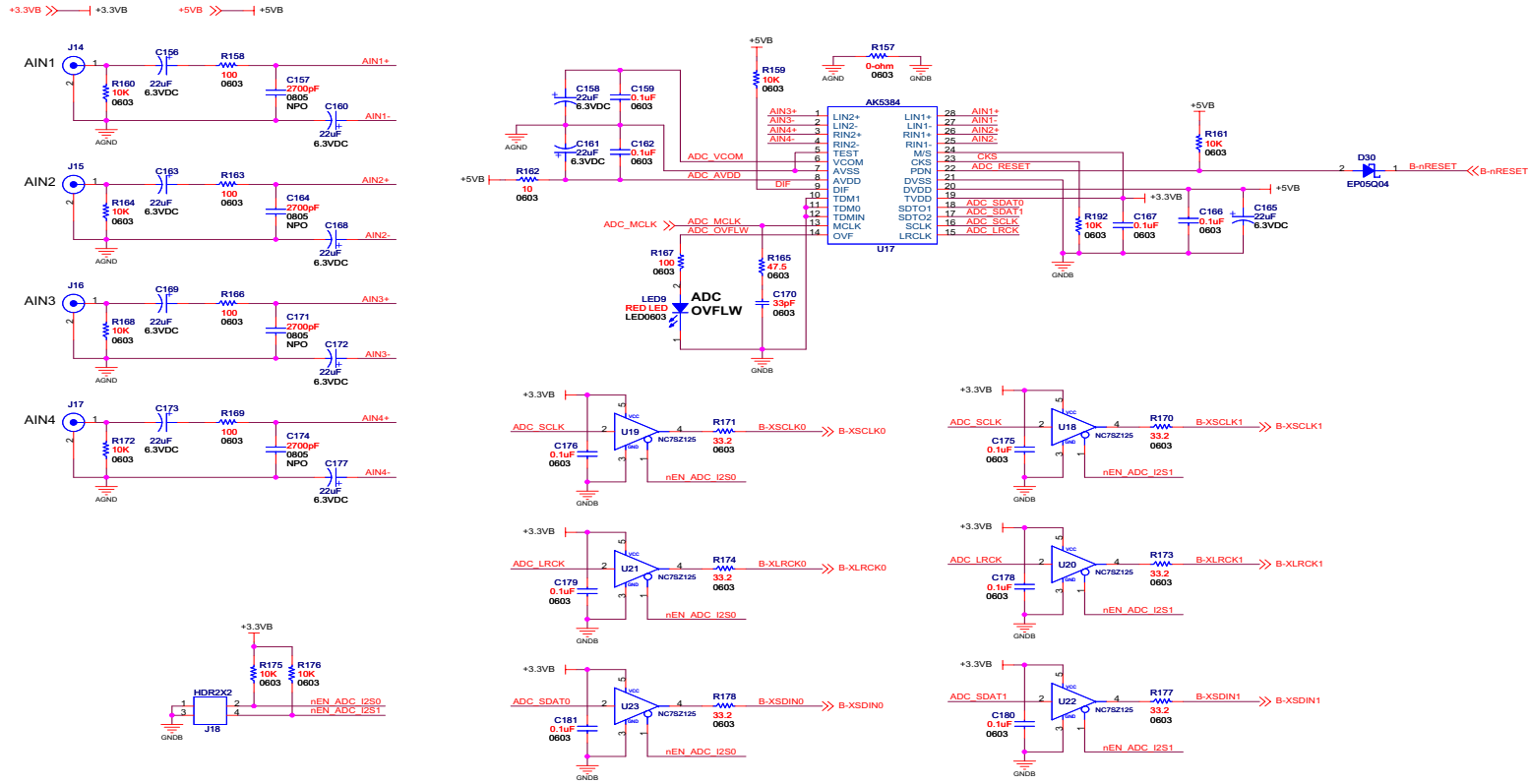

# Hardware Schematics (Continued)

## Breakway - SPDIF I-O

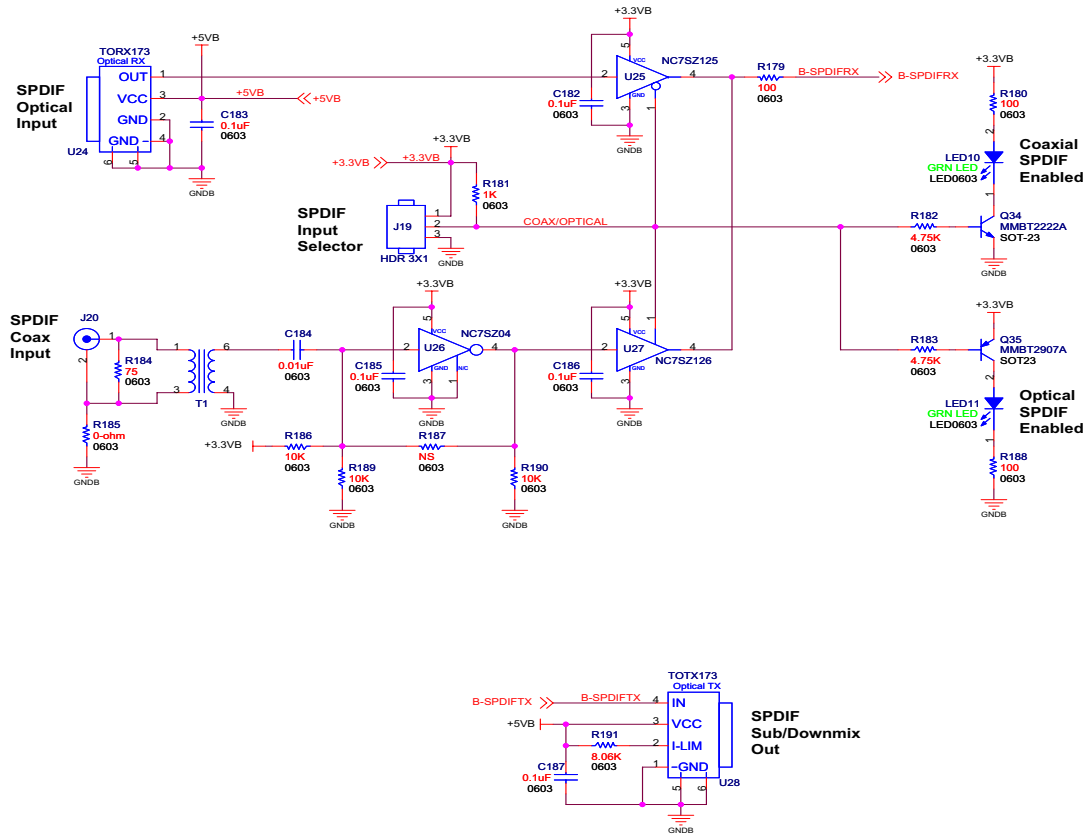

# Hardware Schematics (Continued)

## Breakway Output Board

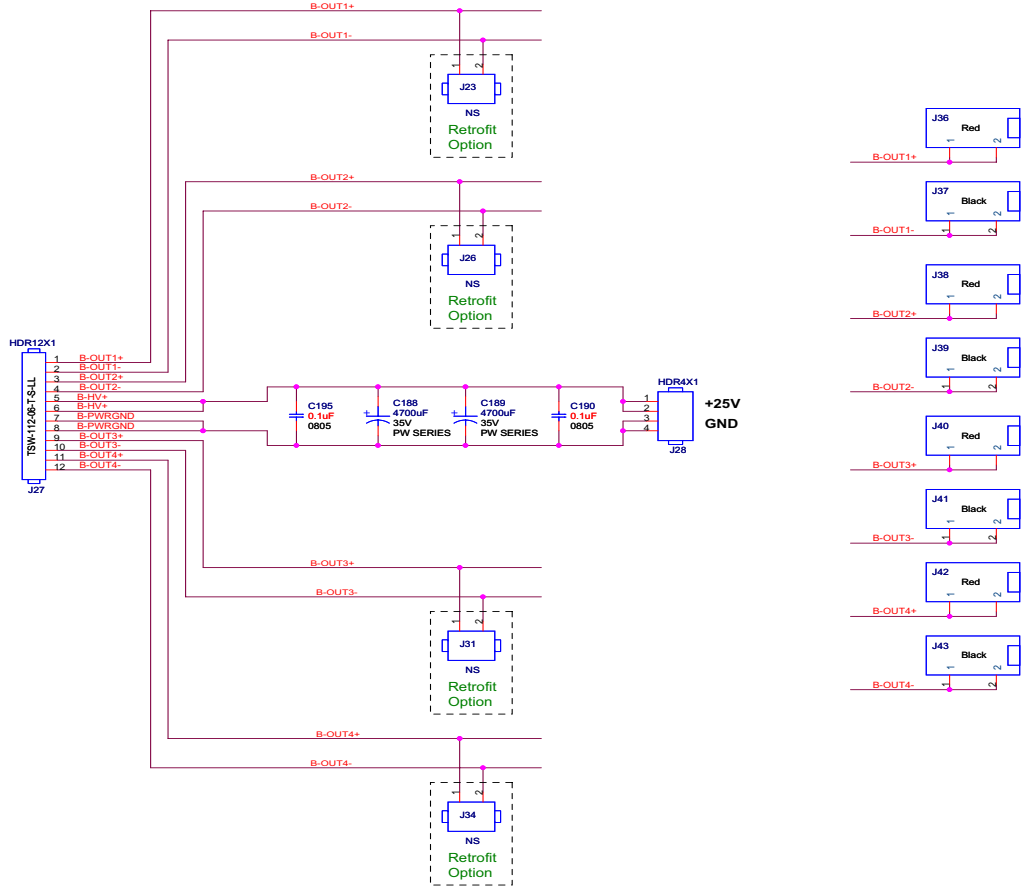

## Revisions

### 02/6/06 Revision 0.0.1 - First Internal Release.

Leveraged existing TXS25-2 evaluation document and updated with basic TXS25-4 information including signal flow, connection diagrams, jumper configurations, schematics, and images.

### 02/14/06 Revision 0.0.2 - Second Internal Release.

- Moved Master Volume in “ Required Power Source”
- Updated 8/4 ohm text and ground referencing text on page 7
- Updated “TABLE 3. DEFAULT DIGITAL/ANALOG AUDIO/CONTROL I/O BOARD FACTORY JUMPER SELECTION” values
- Added continuous sine wave note in See “Testing Setup” on page 21.
- Added 32-192kHz range in See “Testing with Digital Inputs (Recommended Setup)” on page 21. and See “Testing with Analog Inputs” on page 23.
- Updated full scale output text in Table 7 on page 24

Replaced mentions of “module” with “amplifier design”

### 02/15/06 Revision 1.0.0 - First Public Release.

- Updated verbiage on page 7 to improve clarity.
- Updated “ ”
- Updated verbiage and added additional graphics to page 16 in order to describe exactly how to select an analog input, S/PDIF input or I<sup>2</sup>S/Left-Justified input.

### 09/30/08 Revision 1.0.2 (revision 1.0.1 not released)

- Updated Intersil and D2Audio name references.
- Updated and revised photos to better represent platform
- Added updates to power supply references.
- Rewording and text additions throughout for clarity.
- Update to signal flow diagram to include D2Audio SoundSuite

### 10/14/08 Revision 1.0.3 (revision 1.0.1 not released)

- Conversion from book file to Frame

D2™, D2A™, D2Audio™, D2Audio 360°Sound™, D2Audio AccuMatrix™, D2Audio Acoustical Speaker Detect™, D2Audio AFRC (Automatic Frequency Response Compensation)™, D2Audio ARMC (Automatic Room Mode Correction)™, D2Audio Audio Canvas™, D2Audio AudioAlign™, D2Audio Canvas™, D2Audio Canvas 2.0™, D2Audio Canvas II™, D2Audio ClearVoice™, D2Audio DeepBass™, D2Audio DigitalEQ™, D2Audio Electrical Speaker Detect™, D2Audio HILO™, D2Audio LEO (Listening Environment Optimization)™, D2Audio LEOxpc™, D2Audio Load Monitor™, D2Audio Mono2Stereo™, D2Audio Multi-Crossover Digital Bass Management™, D2Audio MultiMix™, D2Audio Multi-Mix™, D2Audio Page-In™, D2Audio Sound Pressure Normalization™, D2Audio SoundSuite™, D2Audio Speaker Detect™, D2Audio Speaker Distance™, D2Audio Speaker EQ (SPEQ)™, D2Audio Speaker Fingerprint™, D2Audio Speaker Impedance™, D2Audio Speaker Polarity™, D2Audio WideSound™, Digital Audio Engine™ and DAE-3™ are trademarks of D2Audio Corporation.

Audistry™ by Dolby, Dolby Headphone™, Dolby Pro Logic II, Dolby Pro Logic II/Ix™, Dolby Pro Logic II™, Dolby Virtual Speaker™, and Surround EX™ are trademarks of Dolby Laboratories Licensing Corporation. Audyssey 2EQ™, Audyssey EQ™, Audyssey MultEQ Pro™, Audyssey MultEQ XT™ and Audyssey MultEQ™ are trademarks of Audyssey Laboratories, Inc. BBE™ is a trademark of BBE Sound, Inc. DTS Neo:6™ is a trademark of Digital Theater Systems, Inc. Logic 7™ is a trademark of Harman International Industries, Incorporated. Microsoft™, Windows™ XP, Windows™ 2000 are trademarks of Microsoft Corporation. SRS Definition™, SRS Dialog Clarity™, SRS FOCUS™, SRS Headphone 360™, SRS TruBass™, SRS TruSurround HD™, SRS TruSurround HD4™, SRS TruSurround XT HD/HD4™, SRS TruSurround XT™, SRS TruSurround™, SRS WOW HD™ and SRS WOW™ are trademarks of SRS Laboratories, Inc. THX Adaptive De-Correlation™, THX Advanced Speaker Array (ASA)™, THX Bass Management with Bass Peak Limiter™, THX Boundary Gain Compensation (BGC)™, THX Cinema Re-EQ™, THX™ Ultra2™ and THX™ Select™ are trademarks of THX Ltd.

*Intersil Corporation reserves the right to make changes in circuit design, software and/or specifications at any time without notice. Accordingly, the reader is cautioned to verify that the Application Note or Technical Brief is current before proceeding.*

For information regarding Intersil Corporation and its products, see [www.intersil.com](http://www.intersil.com)