

DA14535

SMARTBOND TINY™ MODULE Development Kit

This document outlines the system design, configuration options and supported features of DA14535 SMARTBOND TINY™ MODULE Development Kit, PCB version 610-06-A.

Contents

1. References	3
2. Introduction	4
2.1 Features of DA14535 SMARTBOND TINY™ MODULE DB	5
2.2 Features of DA1453x Pro-MB	6
2.3 Features of PMM2 (Power Measurement Module, 500-29-x)	6
3. Get Started with DA14535 SMARTBOND TINY™ MODULE Development Kit	7
3.1 DA14535MOD	7
3.2 Hardware Components of the DEVKIT	7
3.3 First Steps with DA14535 SMARTBOND TINY™ MODULE DEVKIT	8
3.3.1 DA14535 SMARTBOND TINY™ MODULE Development Kit Pro Setup	8
4. DA14535 SMARTBOND TINY™ MODULE Daughterboard	11
4.1 GPIOs and Pin Assignment on DA14535 SMARTBOND TINY™ MODULE DB	13
4.2 Power Section	16
4.2.1 Default Power Supply Option Configuration	16
4.2.2 Optional USB Power Section	16
4.3 Reset Operation	17
4.4 General Purpose Buttons	18
4.5 General Purpose LEDs	19
4.6 MikroBUS™ Module	20
4.7 Debugging Interface	21
4.8 Programming and Debugging Interface Setup	22
4.8.1 1-wire UART, JTAG, RESET	23
4.8.2 2-wire UART, JTAG, RESET	25
4.8.3 4-wire UART, JTAG, RESET	26
5. Known Issues	27
5.1 Keil JTAG Default Clock Speed	27
Appendix A DA14535 SMARTBOND TINY™ MODULE DB [610-06-A]	28
A.1 Schematic	28
A.2 Placed Components	29
6. Revision History	30

Figures

Figure 1. DA14535 SMARTBOND TINY™ MODULE	4
Figure 2. DA14535 SMARTBOND TINY™ MODULE DEVKIT	4
Figure 3. DA14535 (right) and DA14531 (left) SMARTBOND TINY™ MODULE DB	5
Figure 4. Hardware system of DA14535MOD	7
Figure 5. Mount DA14535 SMARTBOND TINY™ MODULE DB to DA1453x Pro-MB with PMM2	8
Figure 6. DA1453x Pro-MB default jumper configuration with DA1453x SMARTBOND TINY™ MODULE DB attached	9
Figure 7. Block diagram of DA14535 SMARTBOND TINY™ MODULE DB	11
Figure 8. Top side components of DA14535 SMARTBOND TINY™ MODULE DB	11
Figure 9. Bottom side of DA14535 SMARTBOND TINY™ MODULE DB	12
Figure 10. GPIOs connectivity on DA14535 SMARTBOND TINY™ MODULE development kit	14
Figure 11. GPIOs circuitry on DA14535 SMARTBOND TINY™ MODULE DB	14
Figure 12. Power option selection for DA14535 SMARTBOND TINY™ MODULE DB	16
Figure 13. Power option default configuration	16
Figure 14. Optional USB power supply section	17
Figure 15. The RESET circuitry	17
Figure 16. Reset button on DA14535 SMARTBOND TINY™ MODULE DB	18
Figure 17. General purpose push buttons on DA14535 SMARTBOND TINY™ MODULE DB	18
Figure 18. Default general purpose push button (SW2) on DA14535 SMARTBOND TINY™ MODULE DB	18
Figure 19. SW2 configuration on DA1453x Pro-MB	19
Figure 20. General purpose LEDs on DA14535 SMARTBOND TINY™ MODULE DB	19
Figure 21. Default LED on DA14535 SMARTBOND TINY™ MODULE DB	19
Figure 22. D5 LED on DA1453x Pro-MB is not driven from DA14535 SMARTBOND TINY™ MODULE	20
Figure 23. Default programming interface of MikroBUS™ module on DA14535 SMARTBOND TINY™ MODULE DB	20
Figure 24. MikroBUS™ module socket on DA14535 SMARTBOND TINY™ MODULE DB	20
Figure 25. Example of mounting MikroBUS™ module	21
Figure 26. Optional debug port	22
Figure 27. DA1453x Pro-MB jumper setup for 1-wire UART, JTAG, and RESET operation	24
Figure 28. DA1453x Pro-MB jumper setup for 2-wire UART, JTAG and RESET operation	25
Figure 29. DA1453x Pro-MB jumper setup for 4-wire UART, JTAG, and RESET operation	26
Figure 30. Keil reported error when opening debugger session	27
Figure 31. Steps to set up JTAG clock speed	27
Figure 32. Schematic of DA14535 SMARTBOND TINY™ MODULE DB [610-06-A]	28
Figure 33. Components on top and bottom sides for DA14535 SMARTBOND TINY™ MODULE DB [610-06-A]	29

Tables

Table 1. DA14535 SMARTBOND TINY™ MODULE DB default functionality	8
Table 2. DA1453x Pro-MB default jumper settings	10
Table 3. Test points description	12
Table 4. GPIO multiplexing on DA14535 SMARTBOND TINY™ MODULE DB	15
Table 5. MikroBUS™ GPIOs multiplexing	21
Table 6. Signals of debugging interface	21
Table 7. Pin assignment of debugging connector J2 on DA14535MOD	22
Table 8. Jumper settings on DA1453x Pro-MB for enabling debugging	22
Table 9. Power, SPI Flash and programming/debugging jumper setup of DA1453x Pro-MB for the TINY™ MODULE	23
Table 10. Pin assignment for DA14535 SMARTBOND TINY™ MODULE configuration 1	23
Table 11. Pin assignment for DA14535 SMARTBOND TINY™ MODULE configuration 2	25
Table 12. Pin assignment for DA14535 SMARTBOND TINY™ MODULE configuration 3	26

Terms and Definitions

DB	Daughterboard
DEVKIT	Development Kit
GPIO	General Purpose Input Output
I ² C	Inter-Integrated Circuit
JTAG	Join Test Action Group
LDO	Low Dropout
No Pop	Not populated, not mounted
PCB	Printed Circuit Board
RX	Receive
SDK	Software Development Kit
SMD	Surface-Mount Device
SoC	System on Chip
SPI	Serial Peripheral Interface
SPI	Serial Peripheral Interface
TX	Transmit
UART	Universal Asynchronous Receiver-Transmitter
USB	Universal Serial Bus

1. References

- [1] DA14535 TINY Module, Datasheet, Renesas Electronics.
- [2] DA14531 TINY Module, Datasheet, Renesas Electronics.
- [3] DA14531, Datasheet, Renesas Electronics.
- [4] DA14535, Datasheet, Renesas Electronics.
- [5] UM-B-114, DA14531 Devkit Pro Hardware, User Manual, Renesas Electronics.
- [6] UM-B-141, DA14531- SMARTBOND TINY™ MODULE Development Kit Hardware, User Manual, Renesas Electronics.
- [7] UM-B-169, DA1453x Hardware Pro Development Kit, Renesas Electronics.
- [8] UM-B-159, DA14535 Module Getting Started Guide, Renesas Electronics.
- [9] UM-B-171 SmartBoot Tool, User Manual, Renesas Electronics.

Note 1 References are for the latest published version, unless otherwise indicated.

2. Introduction

This document describes the development kit of the DA14535 SMARTBOND TINY™ MODULE (DA14535MOD).



Figure 1. DA14535 SMARTBOND TINY™ MODULE

DA14535 SMARTBOND TINY™ MODULE development kit is implemented on a Daughterboard (DB) (610-06-A) and it comes with DA1453x Pro-MB (610-01-B) and PMM2 (500-29-E), [Figure 2](#).

DA14531 SMARTBOND TINY™ MODULE Daughterboard can also utilize same combination of DA1453x Pro-MB (610-01-B) and PMM2 (500-29-E) without modifications.

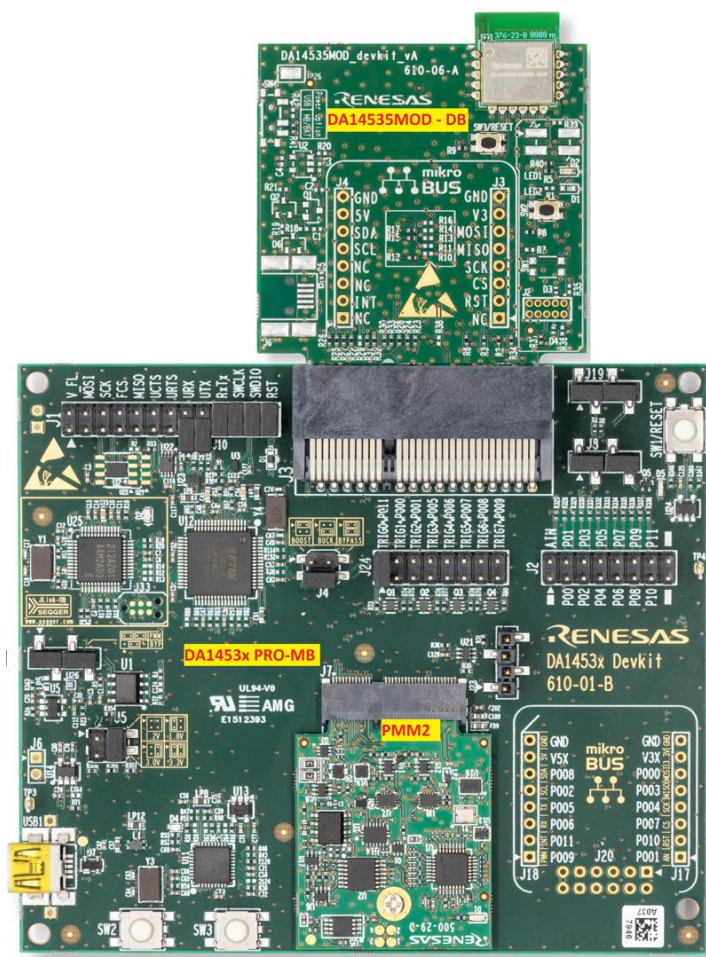

Figure 2. DA14535 SMARTBOND TINY™ MODULE DEVKIT

Except the difference on the mounted Module (DA14535MOD and DA14531MOD), the two daughterboards are identical, and they come with different PCB numbers, 610-06-A for DA14535MOD and 376-25-C for DA14531MOD.

The Development Kit (DEVKIT) is used for software development, programming, debugging, and measuring current, whereas the Daughterboard can be also used stand alone.

The block diagram, the actual board, the various sections, and settings, as well as the connectivity, are presented. The purpose of this Daughterboard is to provide you with the capability for:

- Accessing to the DA14535 SMARTBOND TINY™ MODULE, through UART or JTAG
- Connecting MikroBUS™ module
- User access to general purpose LED(s)
- User access to general purpose button(s)
- Reset button
- Test points for all output signals
- Stand-alone operation.

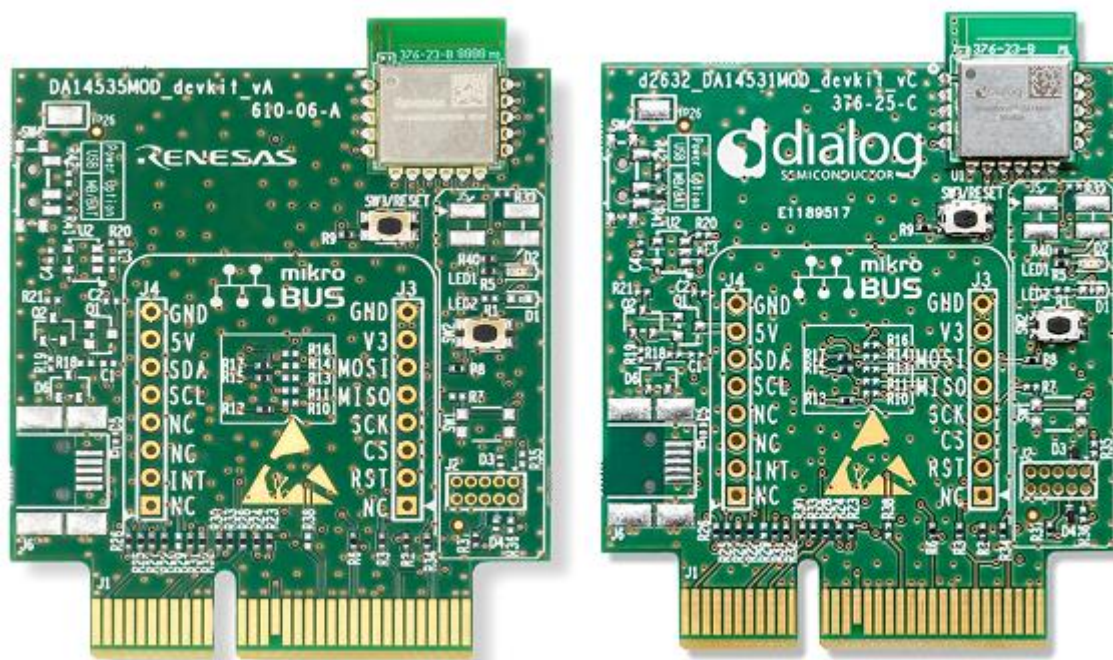

Figure 3. DA14535 (right) and DA14531 (left) SMARTBOND TINY™ MODULE DB

The current document focuses on the DA14535 SMARTBOND TINY™ MODULE Daughterboards (DB) and their connectivity to the DA1453x Pro-MB (610-01-B). DA1453x Pro-MB (610-01-B) and PMM2 (500-29-E) are thoroughly analyzed in Ref. [7].

2.1 Features of DA14535 SMARTBOND TINY™ MODULE DB

- Integrated Renesas DA14535 SMARTBOND TINY™ MODULE
- Different reference numbers for the two Modules, 610-06-A for DA14535MOD
- Reset push button (SW3)
- A set of general-purpose LED and button (LED1 and SW2)
- Supply from VLDO (3V) from DA1453x Pro-MB or from coin cell battery
- Capability of mounting a MikroBUS™ module (J3, J4)
- JTAG and UART interface over DA1453x Pro-MB
- JTAG and UART interface over on-board header (J2)
- Stand-alone operation
- Physical dimension of 58.43x44.46 mm
- Optional features:
 - Power supply option from USB connector (only for power, not for debugging). You must solder the components.
 - Location on board for a second set of LED and button (LED2 and SW1). You must solder the components.

2.2 Features of DA1453x Pro-MB

- A slot to connect a DA1453x Pro-DB which hosts one of the:
 - DA14535MOD, DA14535 SMARTBOND TINY™ MODULE
 - DA14531MOD, DA14531 SMARTBOND TINY™ MODULE
 - DA14531-WLCSP17
 - DA14533- FCQFN22
 - DA14535-FCGQFN24.
 - A slot for attaching a power measurement module (PMM2)
 - Single USB port to provide power and data interfacing to a PC (USB1)
 - Onboard JTAG debugger
 - Virtual 4-wire UART port
 - Onboard 2-Mbit SPI data Flash AT25DF021A-MAHN-T – Not in use for DA14535 SMARTBOND TINY™ MODULE
 - Multiple voltage options (1.25 V, 1.8 V, 3.0 V, and 3.3 V) to supply daughterboards
 - User LEDs and push buttons
 - Voltage translation for the JTAG and UART signals eliminates current leakage during operation.
- For detailed information on DA1453x Pro-MB, see Ref. [7].

2.3 Features of PMM2 (Power Measurement Module, 500-29-x)

- Full scale range 50 mA at 3 V
- Measure accurately down to 1 μ A
- Dedicated Hibernation mode to measure down to 100 nA
- Software trigger inputs
- System voltage measurement.

The power measurement module (PMM2) is an external add-on board that is interfaced (connected) on the DA1453x Pro-MB. For detailed information on PMM2, see Ref. [7].

3. Get Started with DA14535 SMARTBOND TINY™ MODULE Development Kit

3.1 DA14535MOD

The DA14535 SMARTBOND TINY™ MODULE is a Renesas Bluetooth® Low Energy module based on the ultra-low power DA14535 SoC. It uses the same hardware system design and presents identical physical dimensions to DA14531MOD.

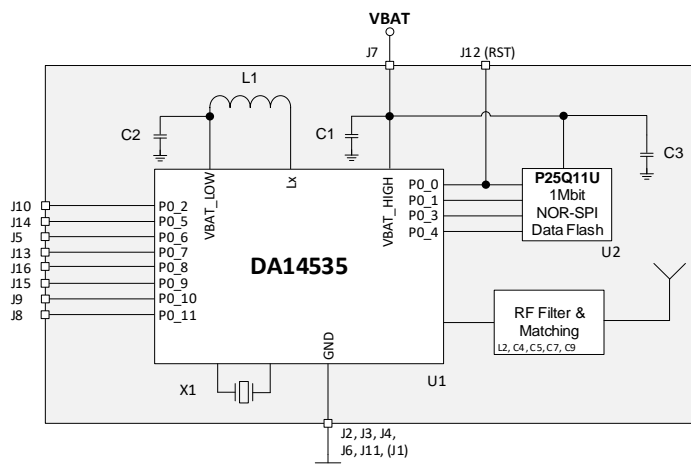

Figure 4. Hardware system of DA14535MOD

A significant difference between the two modules is that DA14535MOD comes with a secondary bootloader, the Renesas SmartBoot, preloaded on the SPI data flash.

Renesas SmartBoot is a secondary bootloader that can be used to add functionality to the boot sequence of DA14535MOD. The features added by the SmartBoot bootloader include two wire UART booting (on GPIOs P0_5, P0_6) and enabling Software Updates over the Air (SUotA), see Ref.

3.2 Hardware Components of the DEVKIT

The DA14535 SMARTBOND TINY™ MODULE Development kit consists of the following parts:

▪ DA14535MOD-00DEVKT-P

Bluetooth Low Energy Development Kit Pro for the DA14535 SMARTBOND TINY™ MODULE. It includes a motherboard and a daughterboard:

• Motherboard, DA1453x Pro-MB

PCBA reference number 610-01-B or later accompanied with Power measurement module, PMM2.
PCBA reference number 500-29-E.

• Daughterboard, DA14535MOD-00F1DB-P

DA14535 SMARTBOND TINY™ MODULE Development Daughterboard (DB)PCBA reference number **610-06-A**.

DA14535 SMARTBOND TINY™ MODULE Development Daughterboard can operate stand-alone.

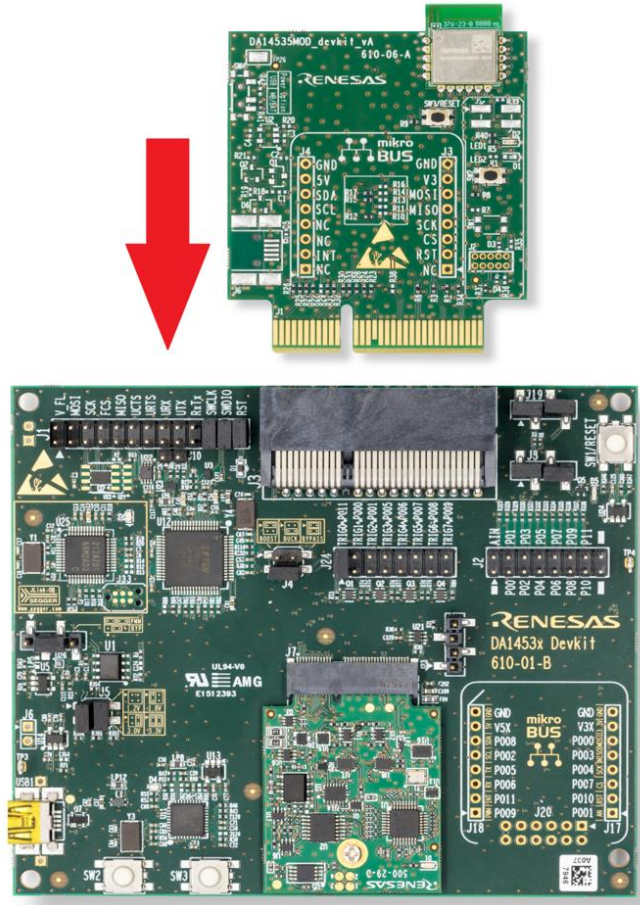

Figure 5. Mount DA14535 SMARTBOND TINY™ MODULE DB to DA1453x Pro-MB with PMM2

3.3 First Steps with DA14535 SMARTBOND TINY™ MODULE DEVKIT

The DA1453x Pro-MB, as well as DA14535 SMARTBOND TINY™ MODULE DB, come with a pre-defined default configuration.

DA14535 SMARTBOND TINY™ MODULE DB functionality is dependent on system hardware configuration, whether daughterboard operates stand-alone or it is attached on the DA1453x Pro-MB. Default functionality is presented in [Table 1](#).

Table 1. DA14535 SMARTBOND TINY™ MODULE DB default functionality

Functionality	DA14535 MODULE DB mounted on Pro-MB	DA14535 MODULE DB stand-alone
Power supply	3 V regulated voltage rail	Mount Coin Cell Battery on BT1
Debugging interface	SWD, UART (configurable), RESET	SWD and RESET (Debugging header J2)
General purpose LEDs	DB: Green LED - D2	Green LED - D2
Buttons	On DB: SW2, SW3 (RESET) On Pro-MB: SW1(RESET), SW2, SW3	SW2, SW3 (RESET)

3.3.1 DA14535 SMARTBOND TINY™ MODULE Development Kit Pro Setup

Default jumper settings applied on DA1453x Pro-MB are shown in [Figure 6](#). System configuration and the functions enabled are presented in [Table 2](#). Before starting the development kit, ensure that the jumper settings are according to [Table 2](#).

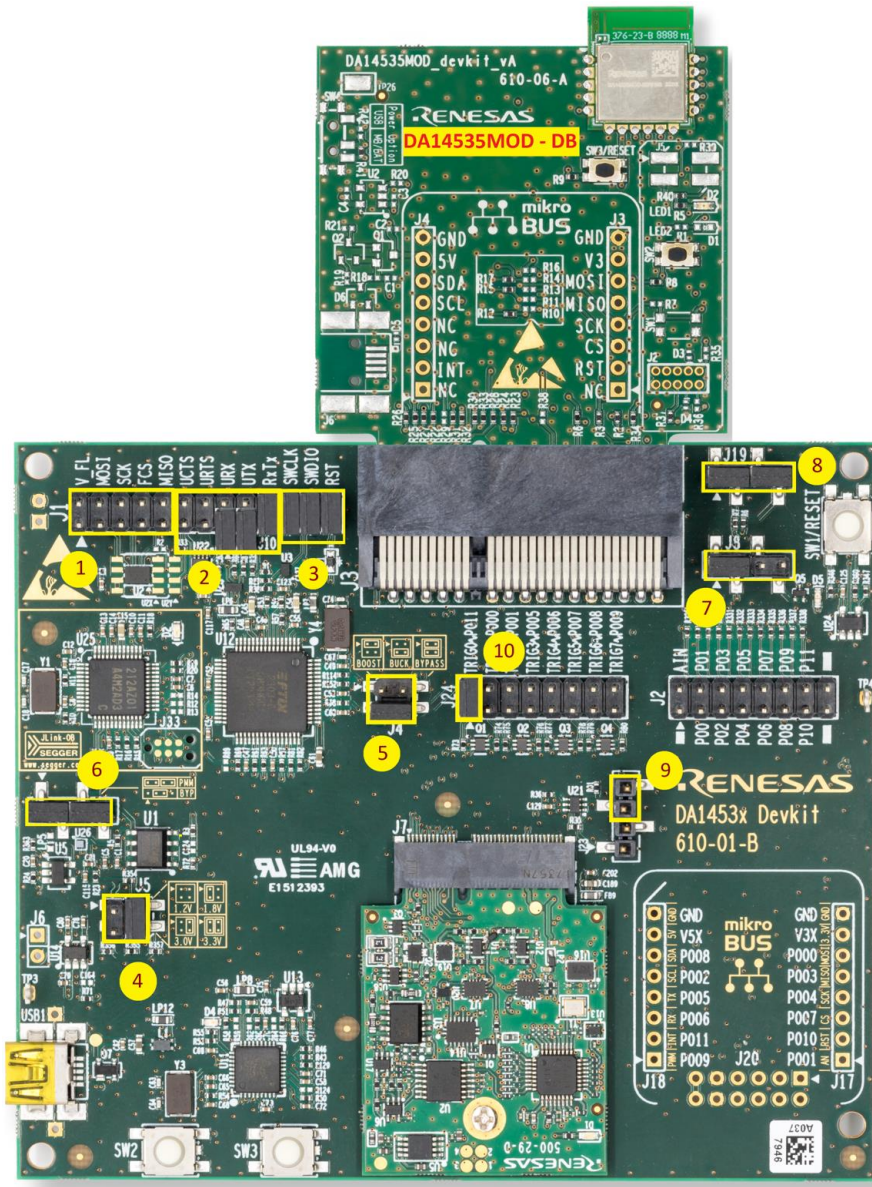

Figure 6. DA1453x Pro-MB default jumper configuration with DA1453x SMARTBOND TINY™ MODULE DB attached

Table 2. DA1453x Pro-MB default jumper settings

Element number	Function	Jumper settings
1	SPI Data Flash (U2) located on DA1453x Pro-MB is disconnected.	J1:1-2, not mounted, J1:3-4, not mounted, J15-6, not mounted, J1:7-8, not mounted, J1:9-10 not mounted.
2	Enable Single – UART,RXTX is connected to P0_5. For different configuration of UART interface, see Section 4.8.	J1.16 - J10.1, mounted, J1.18 - J10.2, mounted, J1:19-20, mounted.
3	Enable SWD and RESET. Connect SWCLK, SWDIO and RESET to DA1453x Pro-MB circuitry.	J1:21-22 (SWCLK), mounted, J1:23-24 (SWDIO), mounted, J1:25-26 (RESET), mounted.
4	DA1453x Module DB is supplied from Pro-MB with 3.0 V.	J5: 1-3, not mounted, J5: 2-4, mounted.
5	Configure DA1453x Pro-MB Power supply for Buck mode.	J4: 1-2, not mounted, J4: 3-4, mounted.
6	Enable Current measurement module (PMM2). Measure current fed from DA1453x Pro-MB to DA1453x MOD.	J9:1-2, mounted, J9:3-4, mounted.
7	Enable RESET to be driven from Segger software.	J8:1-2, mounted.
8	Enable SW2 and SW3 on DA1453x Pro-MB. SW2 is connected to P0_11 through 1 kΩ. SW3 is connected to P0_10 through 1 kΩ.	J19: 1-2, mounted, J19: 3-4, mounted.
9	Not Enable Power On Reset on SW1 pressing.	J23: 3-4 not mounted.
10	Enable Triger_0 on PMM2 circuitry. Connected to P0_11.	J24: 1-2 mounted.

4. DA14535 SMARTBOND TINY™ MODULE Daughterboard

The system on DA14535 SMARTBOND TINY™ Daughterboard (DB) consists of the DA14535 Module, the power section, the general purpose LEDs and Buttons, the debugging connector and the MikroBUS™ section. The system block diagram is shown in Figure 7, and the actual component's location in Figure 8 for top side and Figure 9 for bottom side of Daughterboard.

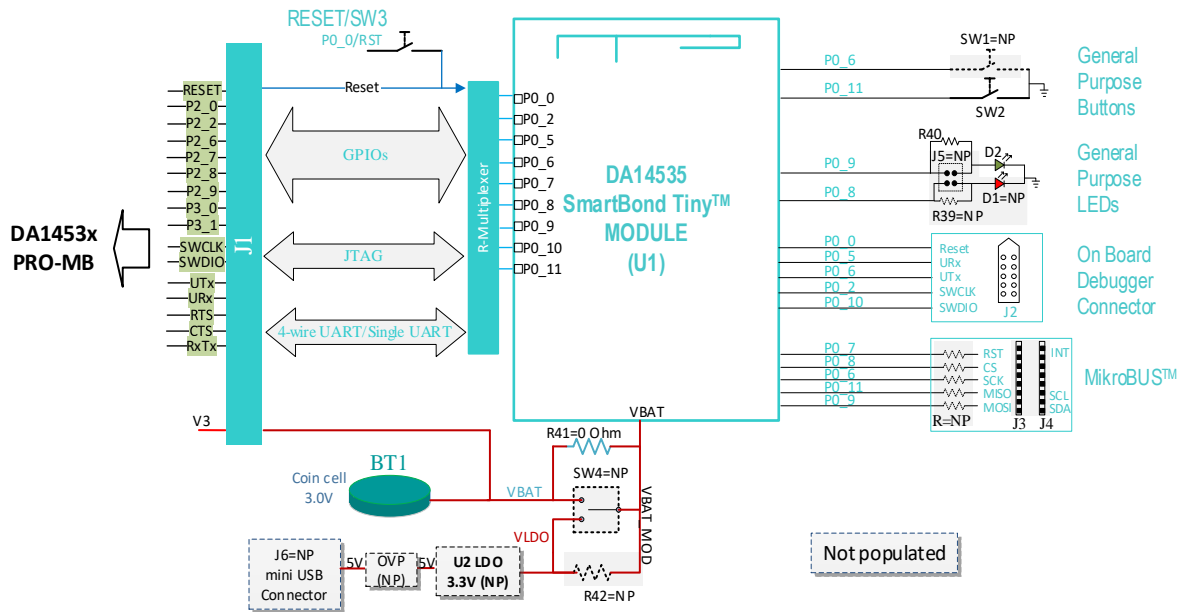

Figure 7. Block diagram of DA14535 SMARTBOND TINY™ MODULE DB

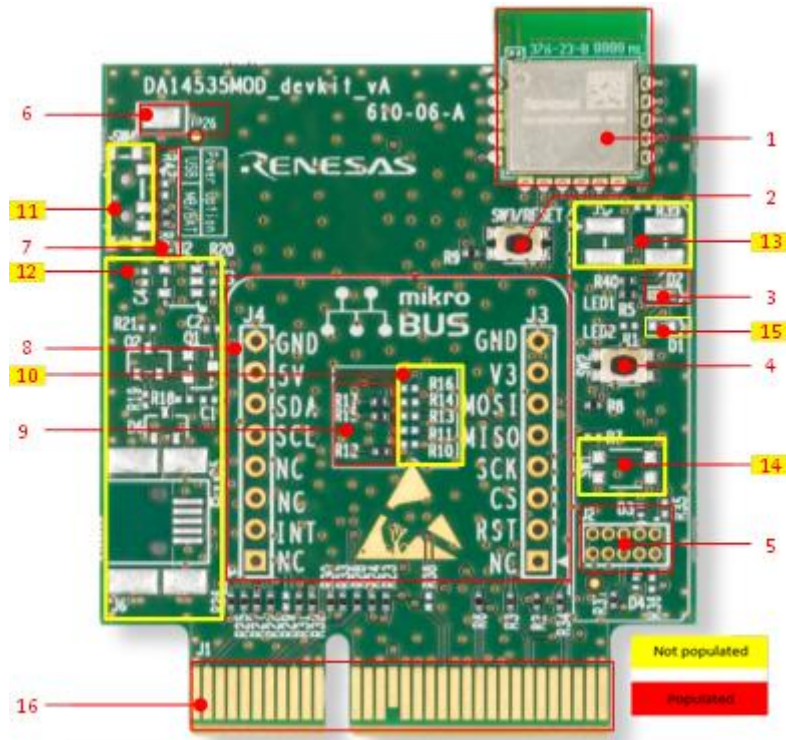

Figure 8. Top side components of DA14535 SMARTBOND TINY™ MODULE DB

The marked and numbered sections of the system are:

1. DA14535 SMARTBOND TINY™ MODULE (U1)
2. Reset button (SW3/RESET)

Test point	Assigned to	Comments
TP8	VLED1	Voltage level of RED LED (D1)
TP9	SWDIO	JTAG Interface DIO Signal
TP10	VLED2	Voltage Level of Green LED (D2)
TP12	RESET	Reset
TP13	SW1	General purpose button (driven from P0_6 signal)
TP14	SW2	General purpose button (driven from P0_11 signal)
TP15	SW3	Reset button (driven from P0_0 signal)
TP16	MikroBUS™ LOGO	Not electrically connected
TP18	5V	USB +5 V voltage level after OVP circuit
TP19	VBUS_IN	USB +5 V voltage level
TP20	VLDO	LDO (U2) 3.3 V output voltage level
TP21	VBAT_MOD	Power supply rail of DA14535 SMARTBOND TINY™ MODULE
TP22	VBAT	Power supply rail of VLDO of DA1453x Pro-MB or external coin cell battery
TP23	ESD_WARNING SIGN	Not electrically connected
TP24	GND	Ground
TP25	GND	Ground
TP26	GND	Ground
TP27	URX	4-wire UART RX Signal
TP28	UTX	4-wire UART TX Signal
TP29	UCTS	4-wire UART CTS Signal
TP30	URTS	4-wire UART RTS Signal

4.1 GPIOs and Pin Assignment on DA14535 SMARTBOND TINY™ MODULE DB

The DA14535 SMARTBOND TINY™ MODULE DB comes in with a pre-defined default configuration. However, due to the low GPIO pin count, several functions are multiplexed and can be enabled as needed. A diagram of GPIO pins multiplexing is shown in [Figure 10](#).

[Figure 11](#) shows pins connectivity on daughterboard. [Table 4](#) presents DA14535 SMARTBOND TINY™ MODULE GPIOs usage on the various functions.

NOTE

Pins P0_1, P0_3, and P0_4 are not available on DA14535 MODULE.

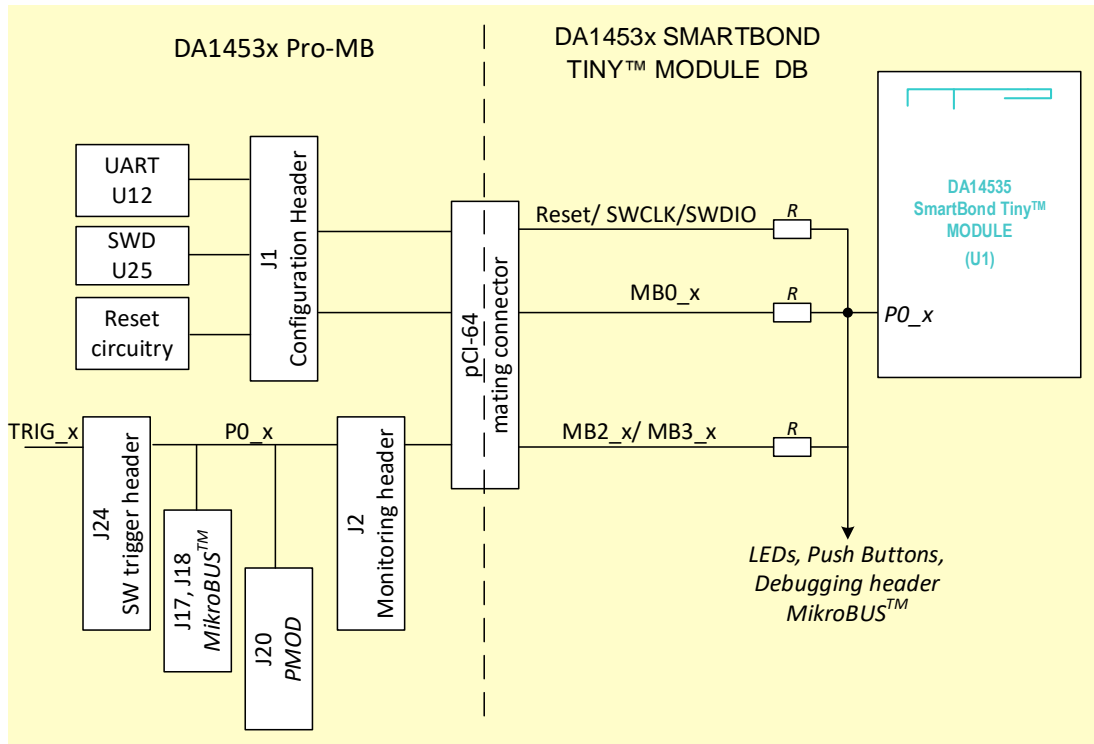

Figure 10. GPIOs connectivity on DA14535 SMARTBOND TINY™ MODULE development kit

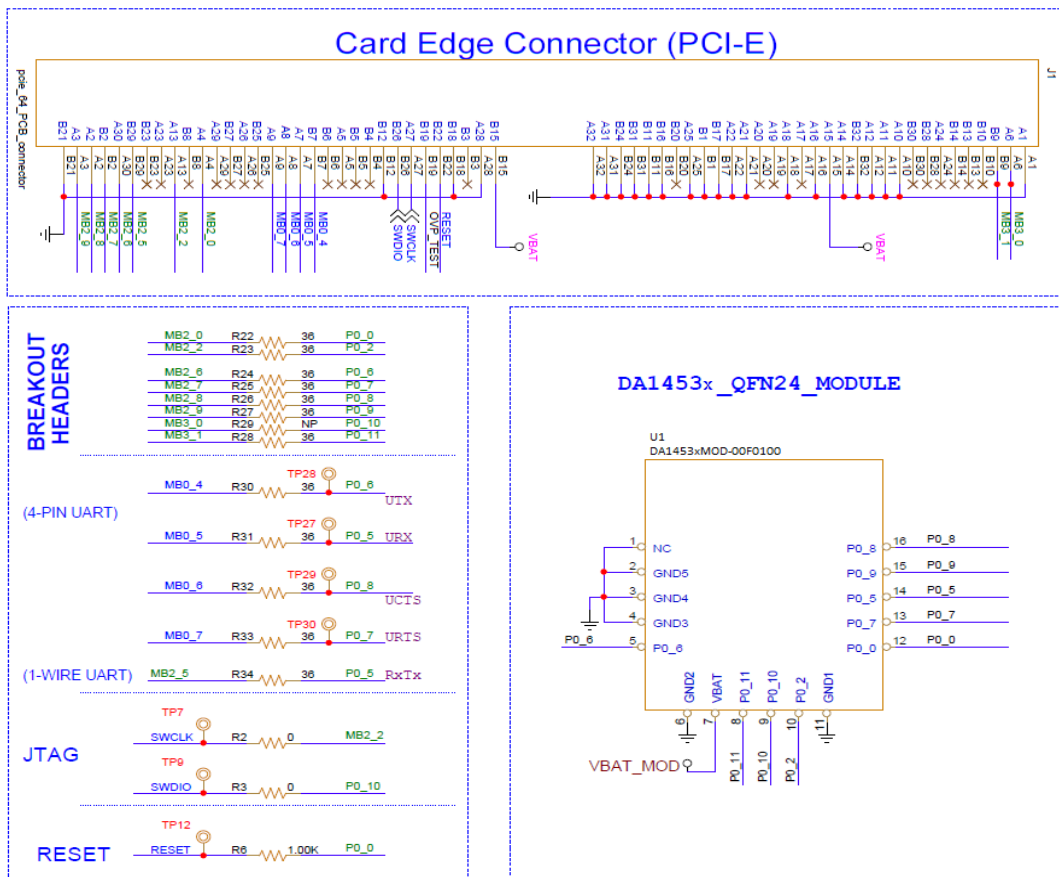

Figure 11. GPIOs circuitry on DA14535 SMARTBOND TINY™ MODULE DB

Table 4. GPIO multiplexing on DA14535 SMARTBOND TINY™ MODULE DB

DA14535 SMARTBOND TINY™ MODULE signals	J1 connector daughterboard	Function 1	Function 2	Function 3
P0_0	-	SW3, RESET Button thru R9 = 4.7K	-	-
	MB2_0	-	-	-
	RESET Thru R34=1K	-	-	-
P0_2	MB2_2	-	-	-
	SWCLK	SWCLK (Debugging connector, J2)	-	-
P0_5	-	RXTX (1-wire UART) thru R34 = 36 Ω on Pro-MB	URX on Debugging connector (J2) Thru R36 = No Pop	-
	MB2_5	-	-	-
	MB0_5	-	URX on Pro-MB J1 :15-16 – No Pop	-
P0_6	-	User button SW1 Thru R7 = No pop SW1 = No Pop	UTX on Debugging connector (J2) Thru R35 = No Pop	MikroBUS™ SCK Thru R13 = No Pop
	MB2_6	-	-	-
	MB0_4	-	UTX on Pro-MB J1 :17-18 – No Pop	-
P0_7	-	MikroBUS™ INT Thru R12 = 10 Ω	-	MikroBUS™ RST Thru R10 = No Pop
	MB2_7	-	-	-
	MB0_7	-	-	-
P0_8	-	MikroBUS™ SCL Thru R15 = 0	RED LED (D1) Thru R1 = No pop	MikroBUS™ CS Thru R11 = No Pop
	MB2_8	-	-	-
	MB0_6	-	-	-
P0_9	-	GREEN LED (D2) Thru R5 = 180 Ω	-	MikroBUS™ MOSI Thru R16 = No Pop
	MB2_9	-	-	-
P0_10	MB3_0	-	-	-
	SWDIO	SWDIO (Debugging connector, J2)	-	-
P0_11	-	SW2 (User button) Thru R8 = 100 Ω	MikroBUS™ SDA Thru R17 = 0 Ω	MikroBUS™ MISO Thru R16 = No Pop
	MB3_1	-	-	-

4.2 Power Section

The power supply on the DA14535 SMARTBOND TINY™ MODULE DB supports these options:

- Power supply from DA1453x Pro-MB. The supply voltage comes from VLDO setup (U5) with output voltage range to meet recommended operating conditions of DA14535 SMARTBOND TINY™ MODULE. For recommended operating conditions, see Ref. [2], and for VLDO selection, Table 9.
- Power supply from Coin cell battery (BT1). Battery case is mounted on bottom side of the daughterboard.

NOTE

Do not mount coin cell battery when daughterboard is supplied from DA1453x Pro-MB.

- (Optional) +5 V USB Power Supply (J6 connector) with Over Voltage Protection Circuit (OVP).

With the power supply from VLDO of DA1453x Pro-MB, you can measure Current drawn from the DA14535 SMARTBOND TINY™ MODULE by using the current sensing circuit and the power profiler of Renesas SmartSnippets Toolbox. For more information regarding current measurement, see Ref. [7].

4.2.1 Default Power Supply Option Configuration

To make power selection between DA1453x Pro-MB VLDO/Coin Cell battery and USB Power Supply, use one of the followings:

- Resistors R41, R42:
 - R41 - Power supply from DA1453x Pro-MB/Coin Cell. This is the default configuration.
 - R42 - VLDO (3.3 V) of USB power section.
- Using SW4 power switch.

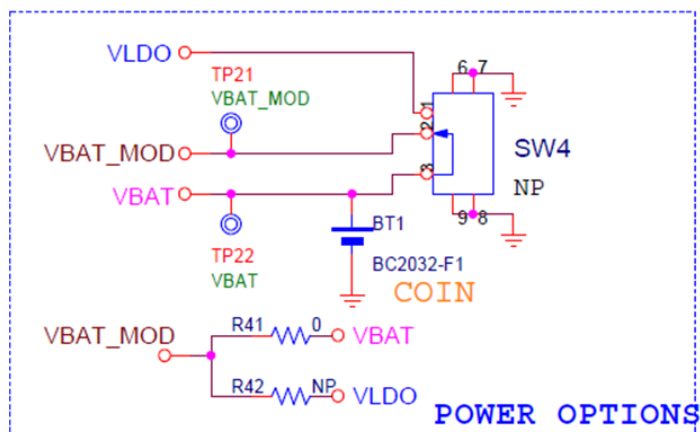

Figure 12. Power option selection for DA14535 SMARTBOND TINY™ MODULE DB

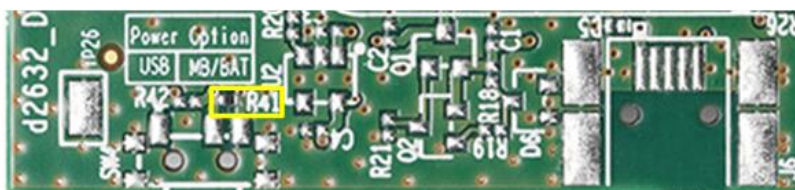

Figure 13. Power option default configuration

4.2.2 Optional USB Power Section

USB power section consists of the following parts:

- Mini Type B USB connector (J6)
- OVP circuit
- LDO (3.3 V) regulator (U2).

USB power section is not populated.

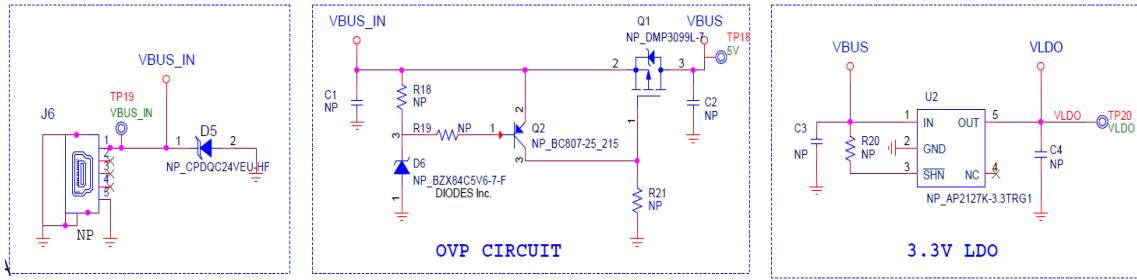

Figure 14. Optional USB power supply section

4.3 Reset Operation

You can reset operation of the DA14535 SMARTBOND TINY™ MODULE using either DA1453x Pro-MB or the DA14535 Module DB.

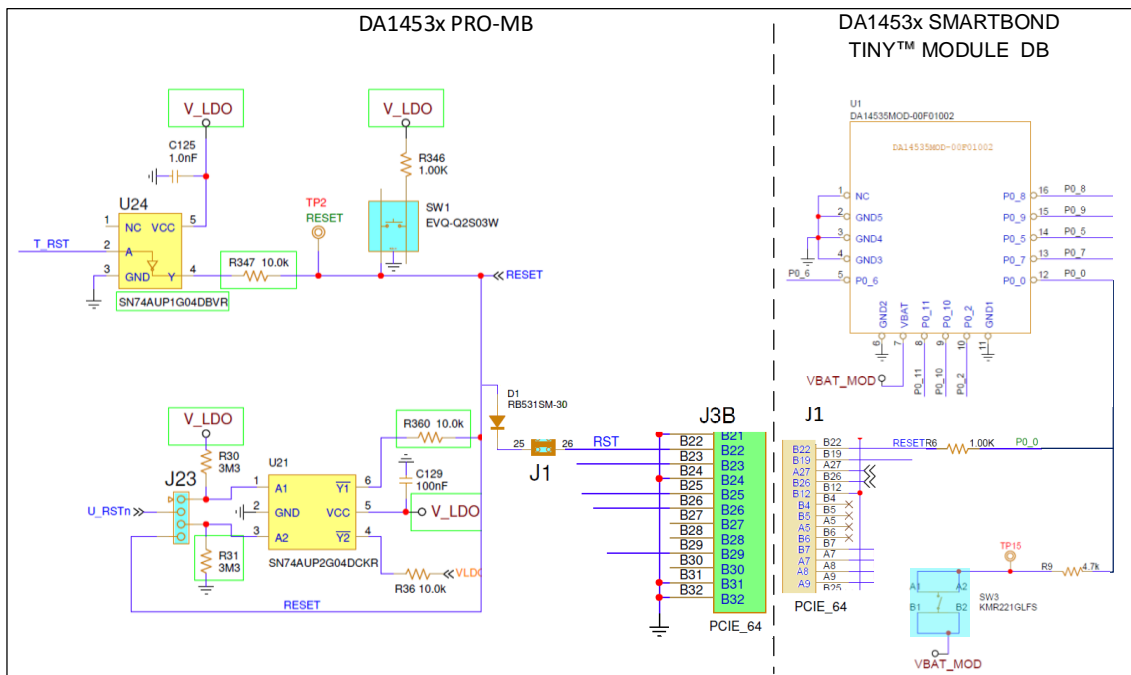

Figure 15. The RESET circuitry

To reset using DA1453x Pro-MB:

- Press the SW1 push button
- JTAG interface (T_RST)
- The U_RSTn signal from UART – not enabled (a jumper must be placed at J23 pin 1-2 and – software required for enabling this feature).

NOTE

- For enabling the Reset on DA1453x Pro-MB, a jumper on J1:25-26 must be placed
- A Power-On Reset (POR) can be generated when SW1 is pressed, if a jumper is placed at J23 pin 3-4

To reset using DA14535 SMARTBOND TINY™ MODULE Daughterboard:

- Press the board RESET button (SW3).

At power-on and before booting in the DA14535 Module, reset is active high, and it is assigned to pin P0_0. After booting, reset assignment and operation is handled by software.

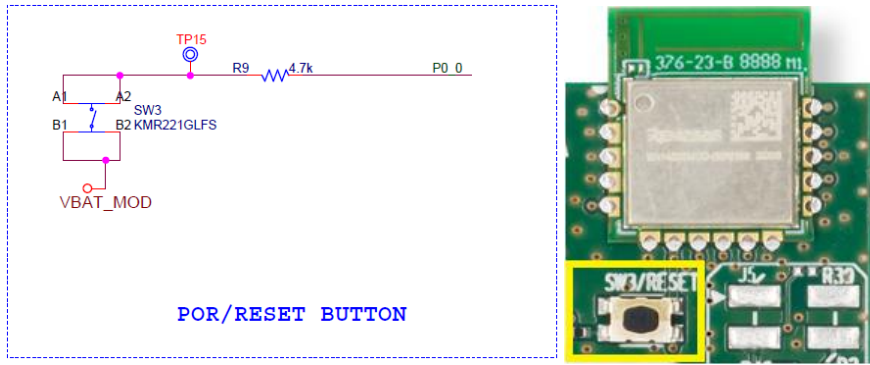

Figure 16. Reset button on DA14535 SMARTBOND TINY™ MODULE DB

4.4 General Purpose Buttons

Push button SW2 is populated and placed on top side of the board (Figure 18). It is connected to P0_11 (Figure 17) and shares the same configuration with SW2 button of DA1453x Pro-MB (SW2 is connected to P3_1 on the motherboard which is P0_11 on DA14535). See Figure 19.

SW1 is not populated (Figure 18). It is connected to P0_6 (Figure 17).

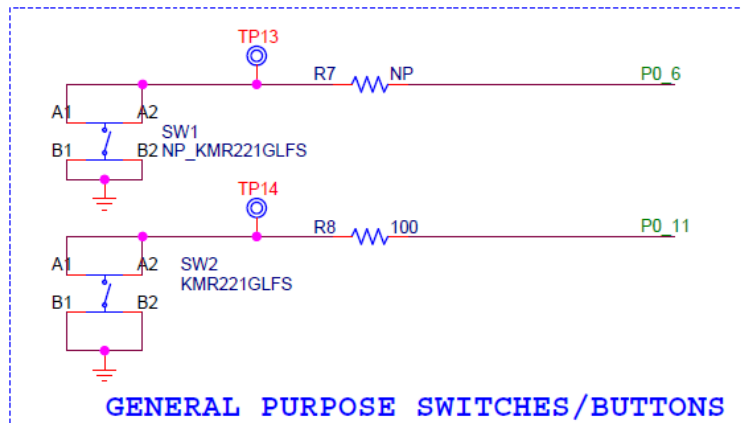

Figure 17. General purpose push buttons on DA14535 SMARTBOND TINY™ MODULE DB



Figure 18. Default general purpose push button (SW2) on DA14535 SMARTBOND TINY™ MODULE DB

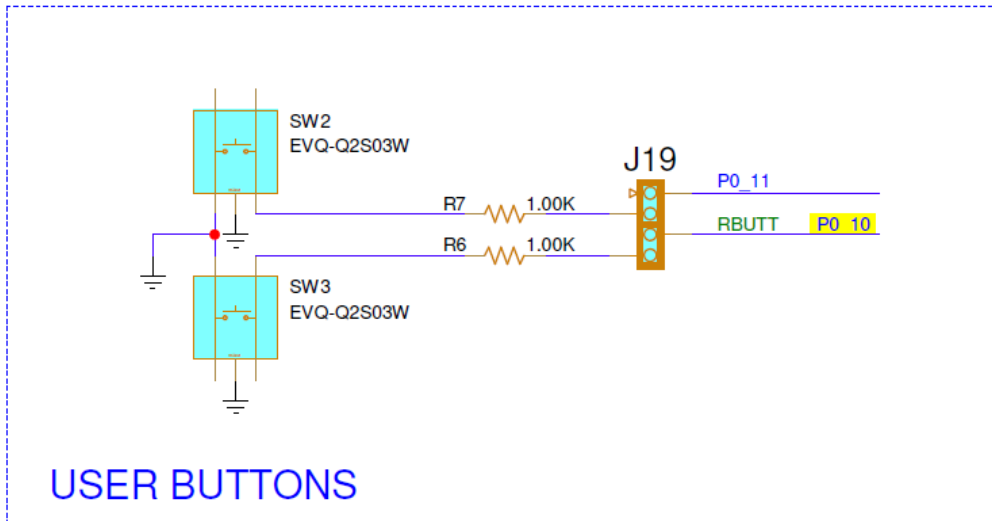

Figure 19. SW2 configuration on DA1453x Pro-MB

4.5 General Purpose LEDs

LED D2 is a general purpose LED, and it is driven by P0_9. LED D1 is driven by P0_8 and it is not populated. You can mount an LED like D2.

General purpose LEDs circuitry is completed with Jumper header J5. J5 is optional and it isolates signals P0_8 and P0_9 when LEDs function is not used, so signals can be directed to other functions.

Header J5 by default is not populated. Instead, resistors R39 and R40 are used to configure the connection of LEDs to the signals (Figure 20 and Figure 21).

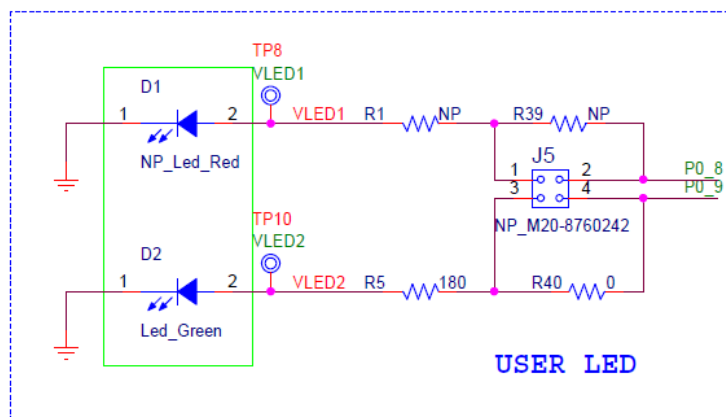

Figure 20. General purpose LEDs on DA14535 SMARTBOND TINY™ MODULE DB

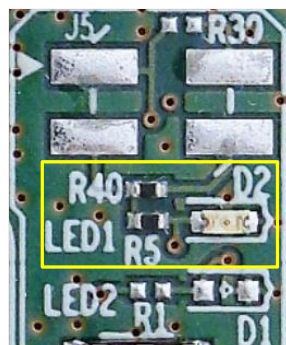

Figure 21. Default LED on DA14535 SMARTBOND TINY™ MODULE DB

LED D5 of DA1453x Pro-MB (Figure 22), is not driven from DA14535MOD and for this reason it is not enabled.

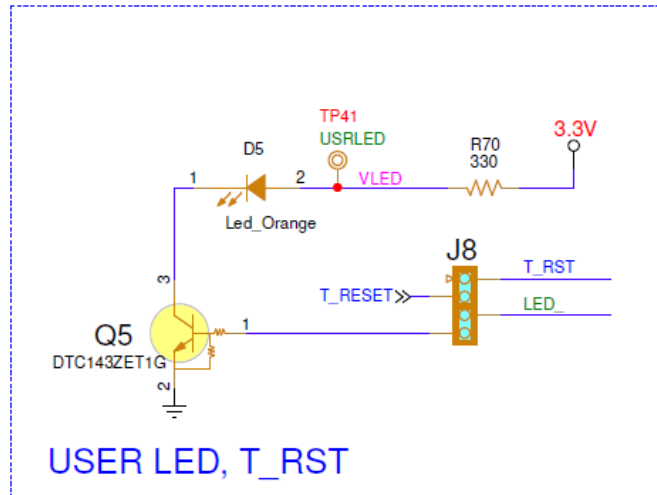

Figure 22. D5 LED on DA1453x Pro-MB is not driven from DA14535 SMARTBOND TINY™ MODULE

4.6 MikroBUS™ Module

The DA14535 SMARTBOND TINY™ MODULE DB can support MikroBUS™ modules. It requires some level of GPIOs multiplexing to avoid conflict with other functions driven by same GPIOs.

A MikroBUS™ module can accept power supply with voltage level of 5 V, 3.3 V, or both, depending on the module. The current configuration of the daughterboard supports only 3.3 V. If a voltage of 5 V is required, then USB power section needs to be populated.

Signals available for MikroBUS™ module are shown in Table 5. I²C signals and INT are the default configuration for the MikroBUS™ module. For SPI interface and RST additional resistors must be populated (Figure 23 and Figure 24).

DA14535 SMARTBOND TINY™ MODULE DB MikroBUS™ does not share same GPIO signals as DA1453x Pro-MB MikroBUS™.



Figure 23. Default programming interface of MikroBUS™ module on DA14535 SMARTBOND TINY™ MODULE DB

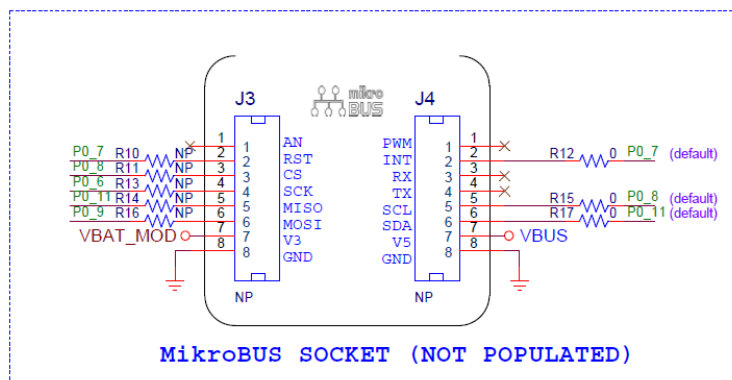

Figure 24. MikroBUS™ module socket on DA14535 SMARTBOND TINY™ MODULE DB

Table 5. MikroBUS™ GPIOs multiplexing

DA14535 SMARTBOND TINY™ MODULE GPIOs	Peripherals	MikroBUS™		
		I ² C	SPI	Other
P0_6	SW1		SCK	-
P0_11	SW2	SDA (default)	MISO	-
P0_8	LED D1	SCL (default)	CS	-
P0_9	LED D2	-	MOSI	-
P0_7	-	-	-	INT (default)
				RST

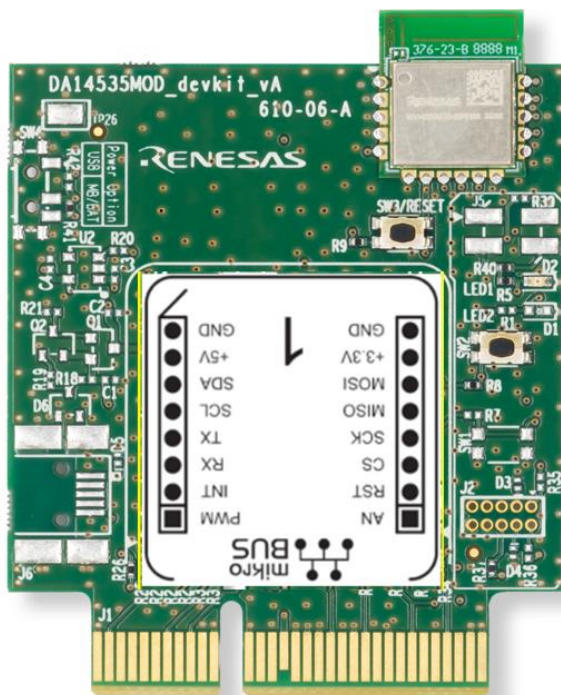

Figure 25. Example of mounting MikroBUS™ module

4.7 Debugging Interface

Debugging can be done from SWD and UART interfaces. SWD is implemented from SWCLK and SWDIO. UART can be configured in three different ways, either as 1-wire, or 2-wires or full UART (4-wires), see [Table 6](#).

Table 6. Signals of debugging interface

Function	Description	DA14535 SMARTBOND TINY™ MODULE DB
SWCLK	SWD Clock	P0_2
SWDIO	SWD Data IO	P0_10
UTX	2-wire or Full UART Transmit	P0_6
URX	2-wire or Full UART Receive	P0_5
UCTS	Full UART Clear to Send	P0_8
URTS	Full UART Request to Send	P0_7
RXTX	Single wire UART Receive and Transmit	P0_5

For stand-alone operation of DA14535 SMARTBOND TINY™ MODULE DB, debugging interface is accessed through debugging connector J2. UART interface consists of UTX and URX and it is not enabled by default.

J2 is located on the DA14535 SMARTBOND TINY™ MODULE DB, see [Table 7](#) and [Figure 26](#).

Table 7. Pin assignment of debugging connector J2 on DA14535MOD

Function	Signals	DA14535 SMARTBOND TINY™ MODULE DEVKIT (J2)	Comments
SWCLK	P0_2	J2:3	-
SWDIO	P0_10	J2:4	-
URX	P0_5	J2:2	No enabled (R36 = Not Pop)
UTX	P0_6	J2:1	No enabled (R35 = Not Pop)
RESET	P0_0	J2:6	-
VBAT	-	J2:7	-

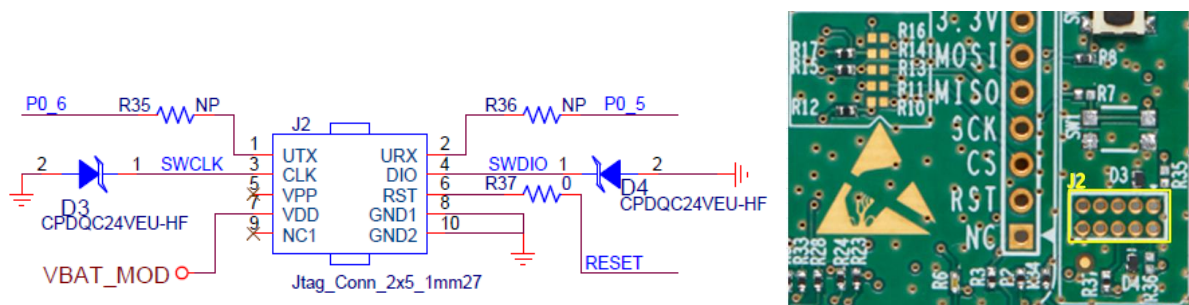
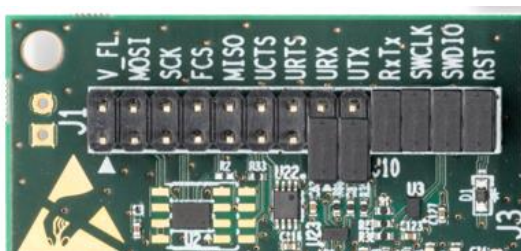

Figure 26. Optional debug port

For DA14535 SMARTBOND TINY™ MODULE DB mounted on DA1453x Pro-MB, SWD, and UART signals are directly mapped and enabled with appropriate jumper settings on header J1 of Pro-MB, see Table 8. For enabling the different configurations, see Section 4.8.

Table 8. Jumper settings on DA1453x Pro-MB for enabling debugging

Function	Signals	DA1453x Pro-MB J1 jumpers settings
SWCLK	P0_2	J1:21-22
SWDIO	P0_10	J1:23-24
URX	P0_5	J1: 15-16
UTX	P0_6	J1: 17-18
URTS	P0_7	J1:13-14
UCTS	P0_8	J1:11-12
RESET	P0_0	J1:25-26



4.8 Programming and Debugging Interface Setup

This section describes the settings required for configuring the Pro-MB development kit for DA14535 SMARTBOND TINY™ MODULE:

- DA14535 SMARTBOND TINY™ MODULE DB
- DA1453x Pro-MB.

Configurations applied by adding/removing jumpers on the DA1453x Pro-MB. No modification is required on the DA14535 SMARTBOND TINY™ MODULE DB.

The SPI flash on DA1453x Pro-MB is not used as DA14535 SMARTBOND TINY™ MODULE contains a SPI data Flash. See [Table 9](#).

The configurations settings are:

- Configuration 1: 1-wire UART, JTAG, and RESET
- Configuration 2: UART (2-wire), JTAG, and RESET
- Configuration 3: Full UART, JTAG, and RESET.

Table 9. Power, SPI Flash and programming/debugging jumper setup of DA1453x Pro-MB for the TINY™ MODULE

Device/Function	Configuration	Setting	Comments
SPI Data Flash	Use SPI Data Flash of DA14535 SMARTBOND TINY™ MODULE	Remove J1: 1-2 J1: 3-4 J1: 5-6 J1: 7-8 J1: 9-10	Remove jumpers from J1 connector that enable Pro-MB SPI Data Flash
Voltage provided to DA14535 (VLDO)	-	J9:1-2 J9:3-4	Current sense circuit of Pro-MB
	1.8 V	J5:1-3	Default voltage for TINY™ MODULE
	3.0 V	J5:2-4	
	3.3 V	J5:1-3	
J5:2-4			
DA14535 DCDC configuration	Buck	J4:3-4	Power mode of TINY™ MODULE
Programming/debugging interface	1-wire UART	J1:19-20 J10:1-J1:15 J10:2-J1:17	Default
	2-wire UART	J1:15-16 J1:17-18	-
	4 wire UART	J1:11-12 J1:13-14 J1:15-16 J1:17-18	-
	JTAG	J1:21-22 J1:23-24	-
	RESET	J1:25-26	-

4.8.1 1-wire UART, JTAG, RESET

Table 10. Pin assignment for DA14535 SMARTBOND TINY™ MODULE configuration 1

Configuration		P0_0	P0_2	P0_5	P0_10
1	JTAG and 1-wire UART	Reset	SWLCK	RXTX	SWDIO

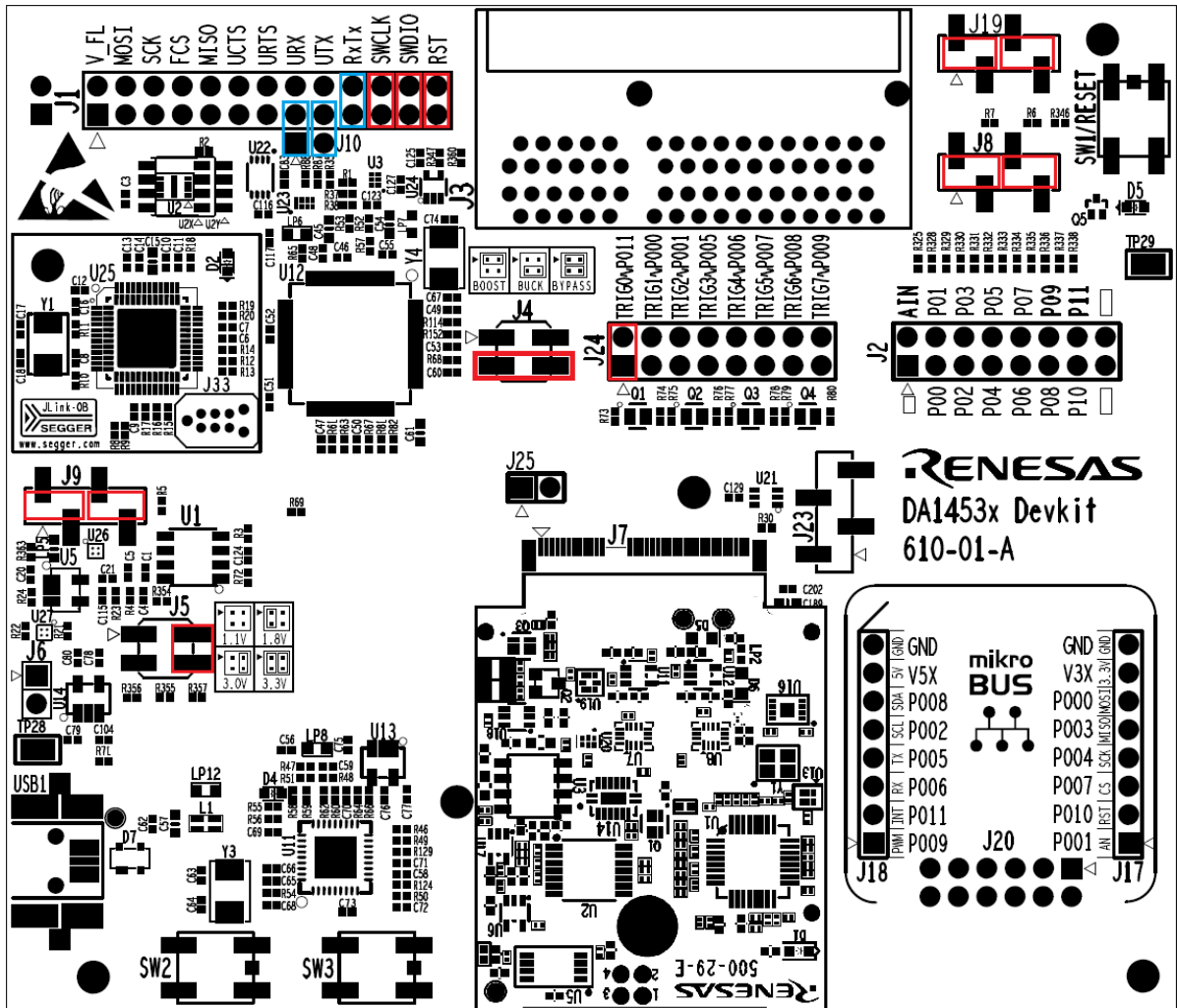

Figure 27. DA1453x Pro-MB jumper setup for 1-wire UART, JTAG, and RESET operation

4.8.2 2-wire UART, JTAG, RESET

Table 11. Pin assignment for DA14535 SMARTBOND TINY™ MODULE configuration 2

Configuration	P0_0	P0_2	P0_6	P0_5	P0_10
2	JTAG and 2-wire UART	Reset	SWLCK	RX	SWDIO

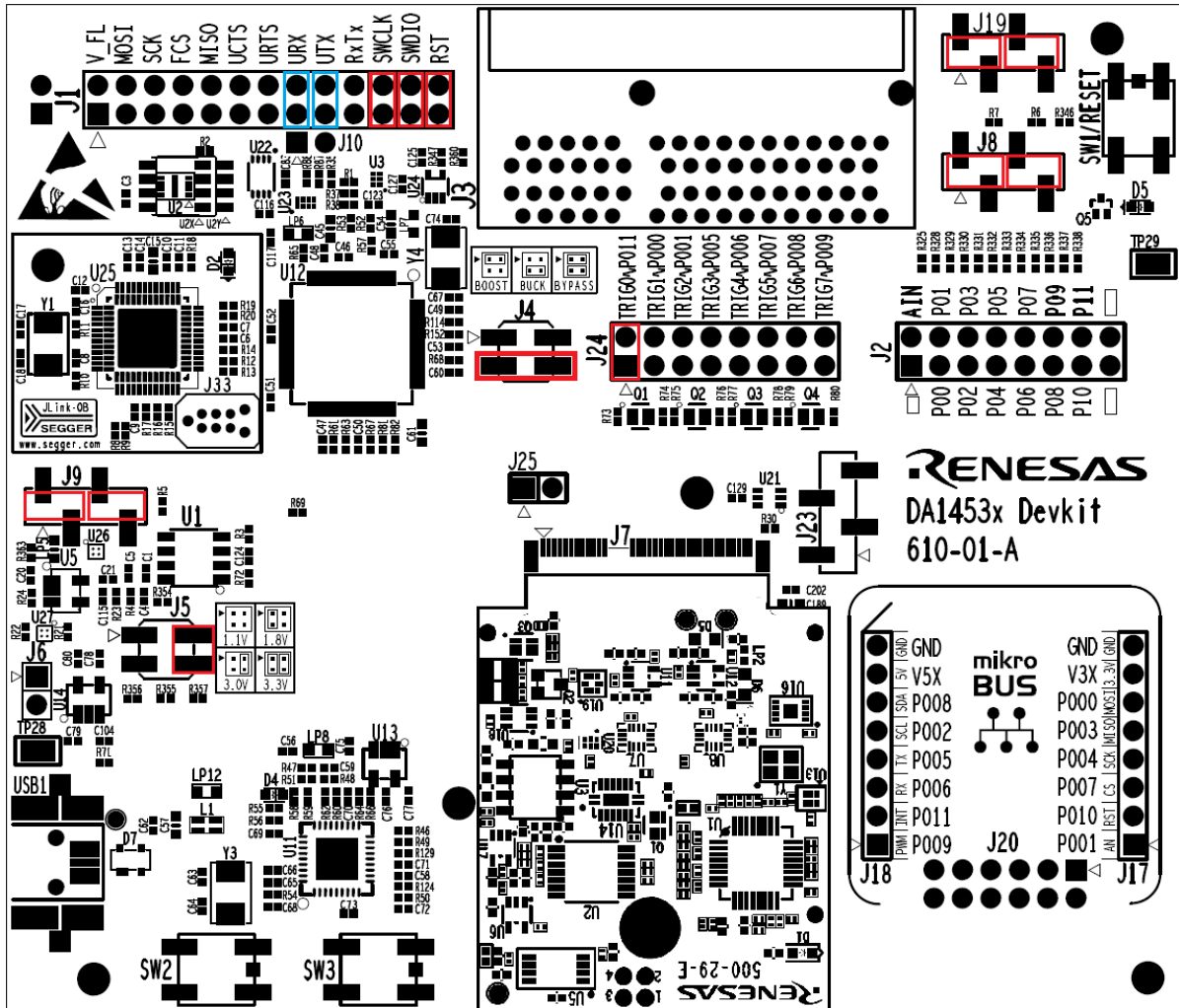

Figure 28. DA1453x Pro-MB jumper setup for 2-wire UART, JTAG and RESET operation

4.8.3 4-wire UART, JTAG, RESET

Table 12. Pin assignment for DA14535 SMARTBOND TINY™ MODULE configuration 3

Configuration	P0_0	P0_2	P0_6	P0_5	P0_7	P0_8	P0_10
3	JTAG and 4-wire UART	Reset	SWLCK	TX	RX	RTS	SWDIO

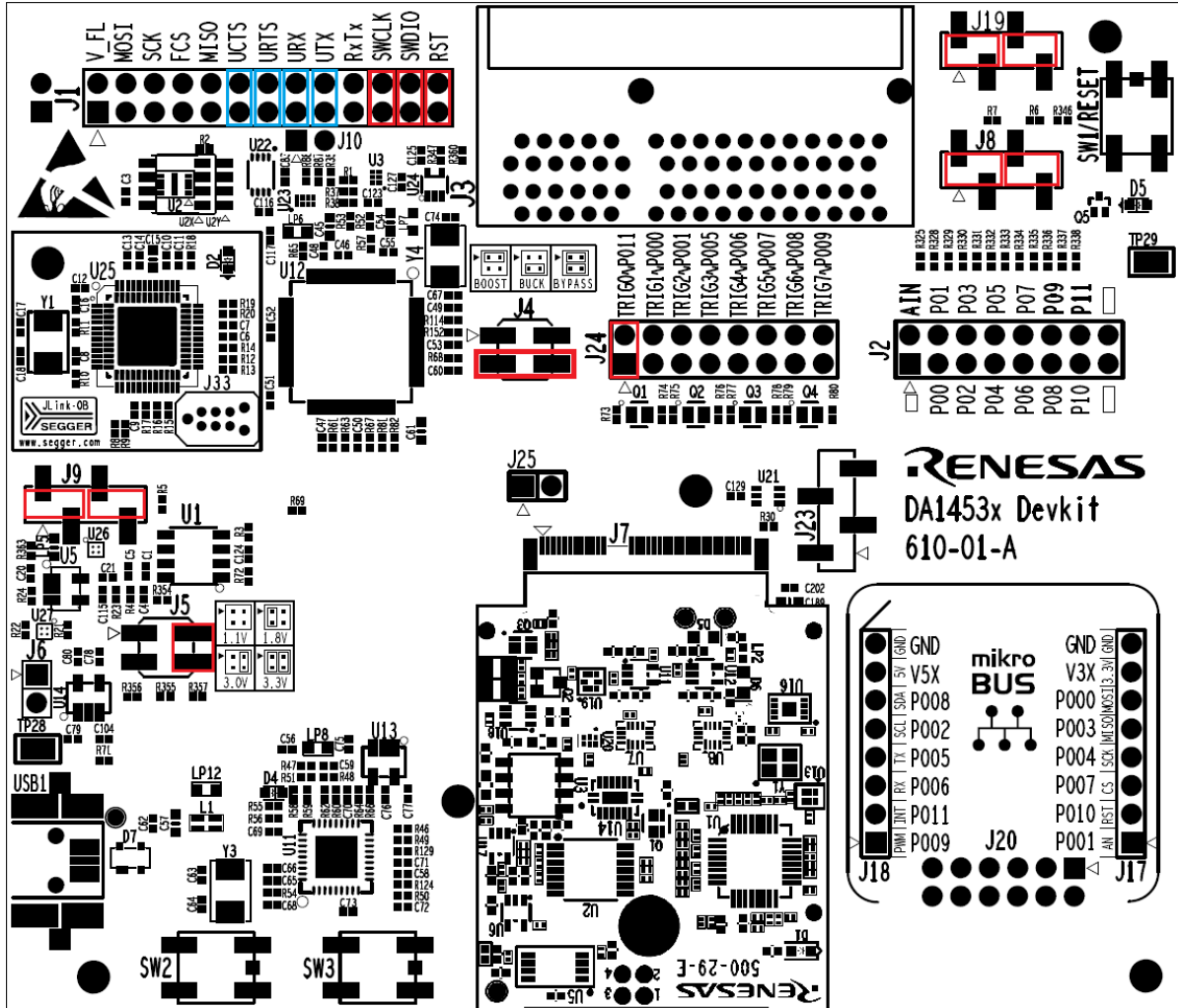

Figure 29. DA1453x Pro-MB jumper setup for 4-wire UART, JTAG, and RESET operation

5. Known Issues

5.1 Keil JTAG Default Clock Speed

When programming DA14535 SMARTBOND TINY™ MODULE using Keil, the following error may occur when you try to open the debugger session (Figure 30).

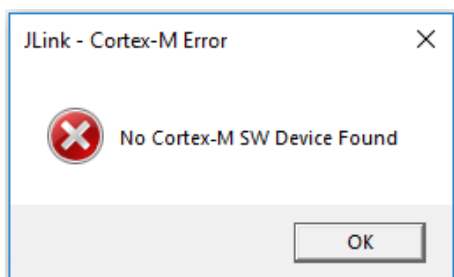

Figure 30. Keil reported error when opening debugger session

You must lower the JTAG clock speed to 2 MHz following the steps shown in Figure 31.

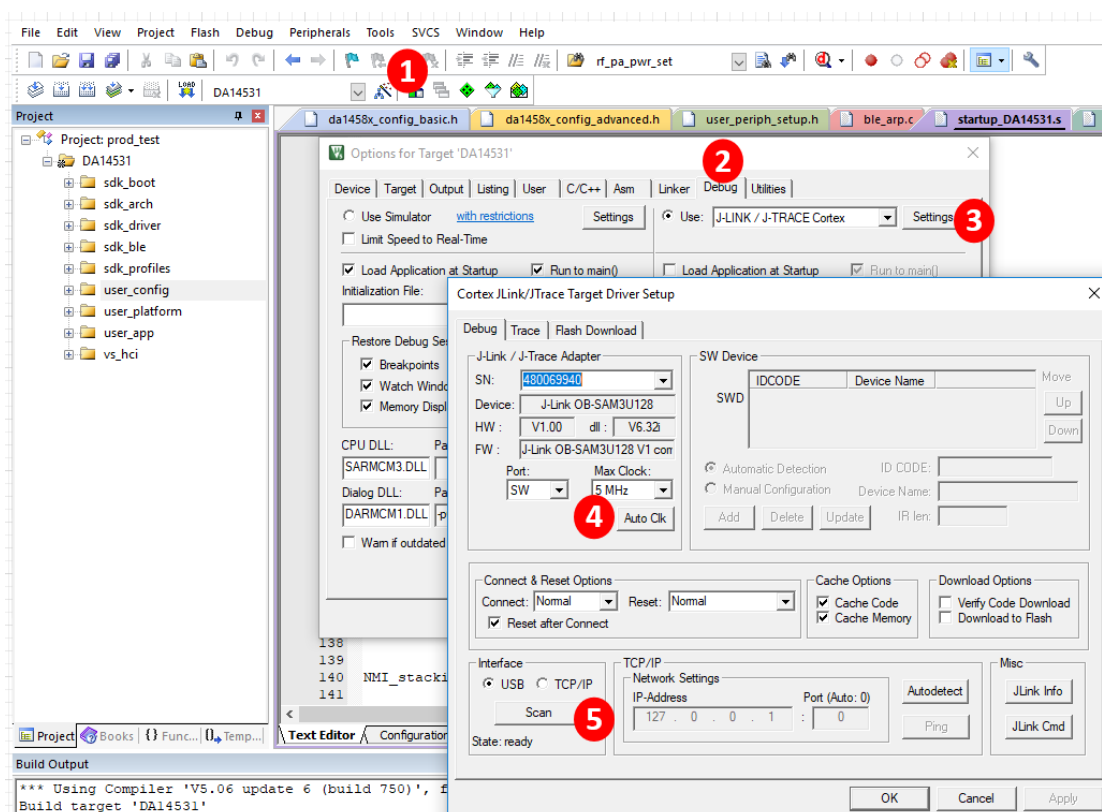

Figure 31. Steps to set up JTAG clock speed

Steps:

1. Open options for Target device.
2. Select the **Debug** tab.
3. Click **Settings** for J-Link/J-TRACE Cortex.
4. Change default max clock speed from 5 MHz to 2 MHz.
5. Click **Scan** to detect the ARM® Core.

Appendix A DA14535 SMARTBOND TINY™ MODULE DB [610-06-A]

A.1 Schematic

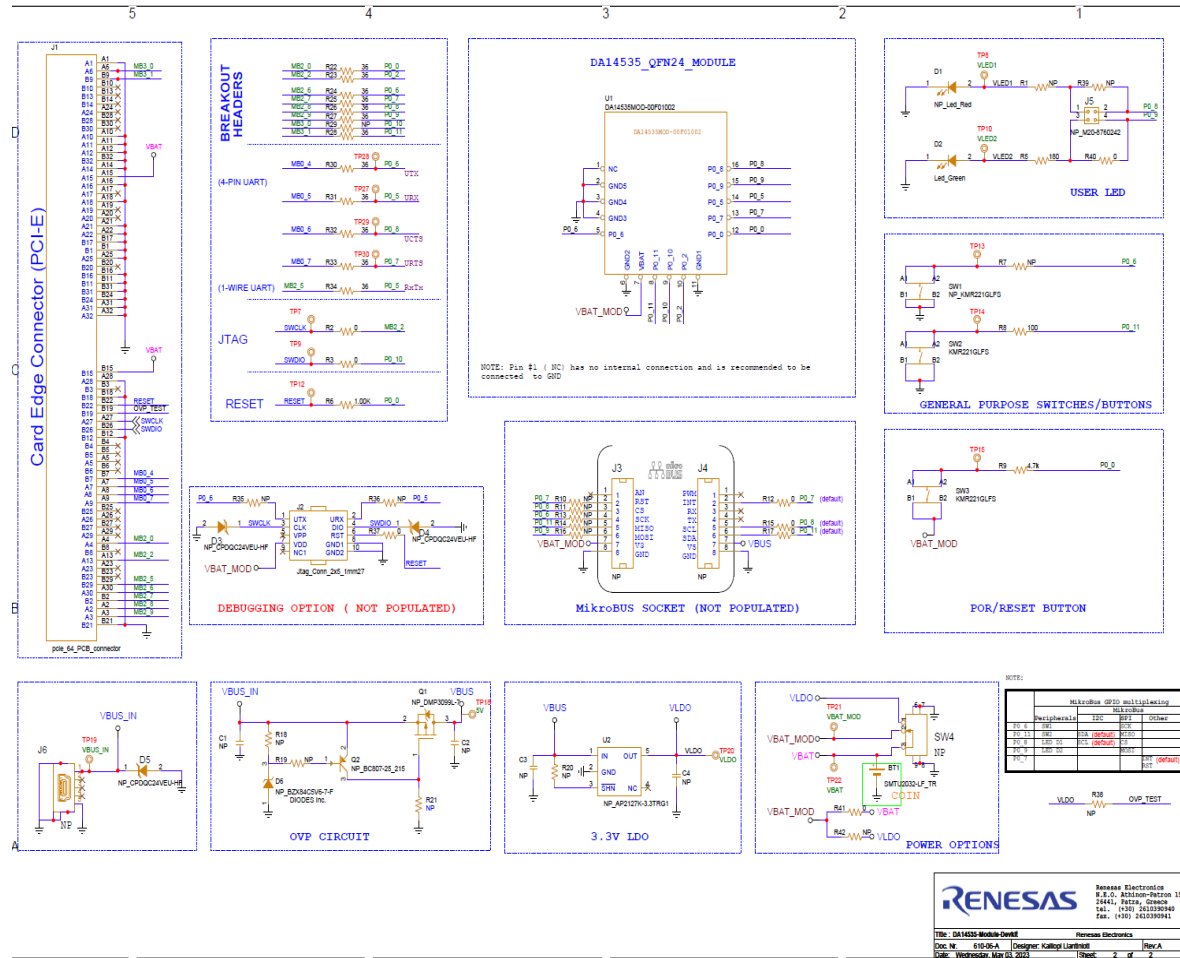

Figure 32. Schematic of DA14535 SMARTBOND TINY™ MODULE DB [610-06-A]

A.2 Placed Components

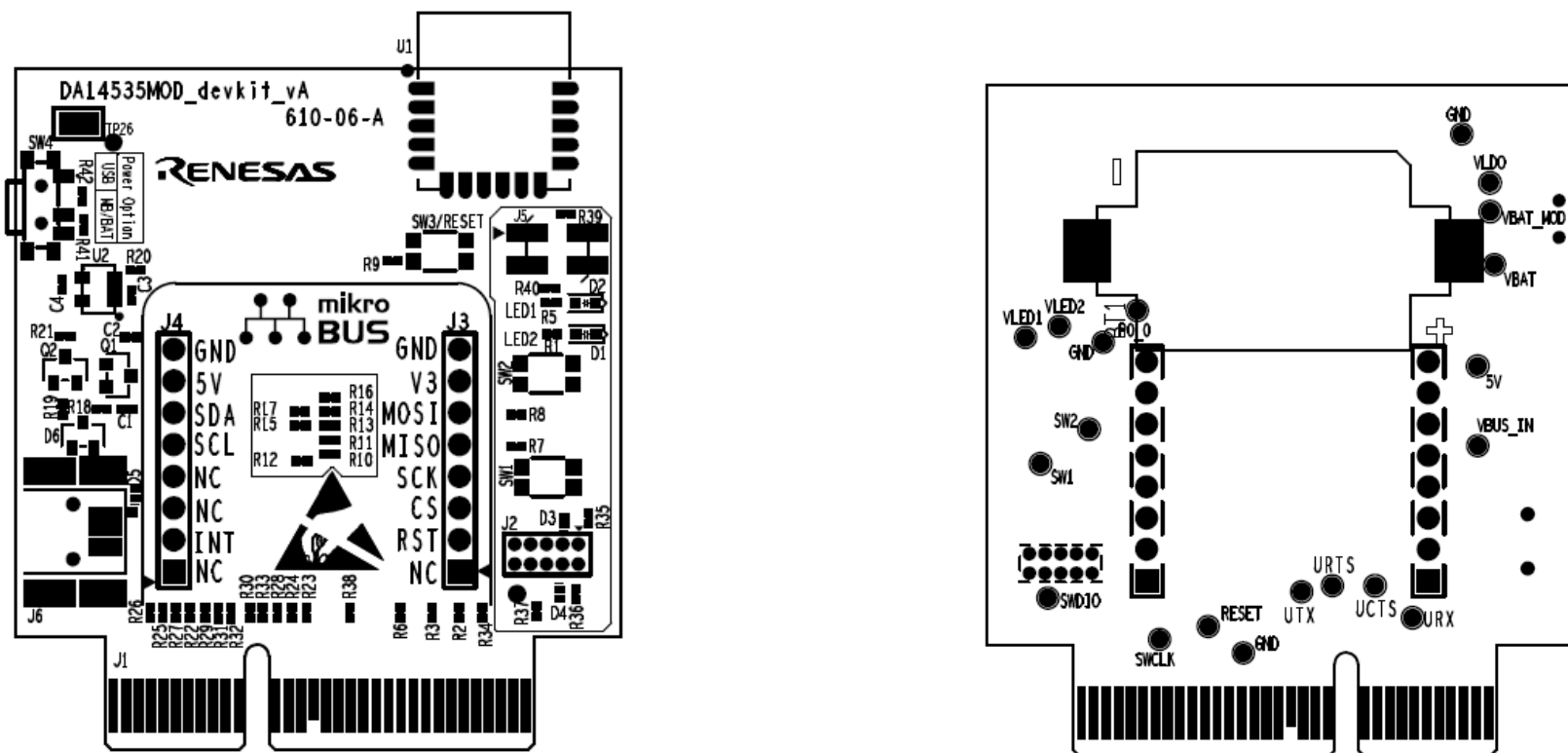

Figure 33. Components on top and bottom sides for DA14535 SMARTBOND TINY™ MODULE DB [610-06-A]

6. Revision History

Revision	Date	Description
1.1	July 19, 2024	Changed to company template
1.0	Mar 22, 2024	Initial version.

Status Definitions

Status	Definition
DRAFT	The content of this document is under review and subject to formal approval, which may result in modifications or additions.
APPROVED or unmarked	The content of this document has been approved for publication.

RoHS Compliance

Renesas' suppliers certify that its products are in compliance with the requirements of Directive 2011/65/EU of the European Parliament on the restriction of the use of certain hazardous substances in electrical and electronic equipment. RoHS certificates from our suppliers are available on request.

IMPORTANT NOTICE AND DISCLAIMER

RENESAS ELECTRONICS CORPORATION AND ITS SUBSIDIARIES (“RENESAS”) PROVIDES TECHNICAL SPECIFICATIONS AND RELIABILITY DATA (INCLUDING DATASHEETS), DESIGN RESOURCES (INCLUDING REFERENCE DESIGNS), APPLICATION OR OTHER DESIGN ADVICE, WEB TOOLS, SAFETY INFORMATION, AND OTHER RESOURCES “AS IS” AND WITH ALL FAULTS, AND DISCLAIMS ALL WARRANTIES, EXPRESS OR IMPLIED, INCLUDING, WITHOUT LIMITATION, ANY IMPLIED WARRANTIES OF MERCHANTABILITY, FITNESS FOR A PARTICULAR PURPOSE, OR NON-INFRINGEMENT OF THIRD-PARTY INTELLECTUAL PROPERTY RIGHTS.

These resources are intended for developers who are designing with Renesas products. You are solely responsible for (1) selecting the appropriate products for your application, (2) designing, validating, and testing your application, and (3) ensuring your application meets applicable standards, and any other safety, security, or other requirements. These resources are subject to change without notice. Renesas grants you permission to use these resources only to develop an application that uses Renesas products. Other reproduction or use of these resources is strictly prohibited. No license is granted to any other Renesas intellectual property or to any third-party intellectual property. Renesas disclaims responsibility for, and you will fully indemnify Renesas and its representatives against, any claims, damages, costs, losses, or liabilities arising from your use of these resources. Renesas' products are provided only subject to Renesas' Terms and Conditions of Sale or other applicable terms agreed to in writing. No use of any Renesas resources expands or otherwise alters any applicable warranties or warranty disclaimers for these products.

(Disclaimer Rev.1.01 Jan 2024)

Corporate Headquarters

TOYOSU FORESIA, 3-2-24 Toyosu,
Koto-ku, Tokyo 135-0061, Japan
www.renesas.com

Trademarks

Renesas and the Renesas logo are trademarks of Renesas Electronics Corporation. All trademarks and registered trademarks are the property of their respective owners.

Contact Information

For further information on a product, technology, the most up-to-date version of a document, or your nearest sales office, please visit www.renesas.com/contact-us/.